

AUTOCHEM[®] II 2920

AUTOMATED CATALYST CHARACTERIZATION SYSTEM



OPERATOR MANUAL

292-42831-01
Apr 2024
(Rev A)

TRADEMARKS

Alconox is a registered trademark of the Alconox Company.
AutoChem is a registered trademark of Micromeritics Instrument Corporation.
Chemraz is a registered trademark of Green, Tweed.
Hastelloy is a registered trademark of Haynes International, Inc.
Kalrez is a registered trademark of DuPont Dow Elastomers L.L.C.
Kimwipe is a registered trademark of Kimberly-Clark Corporation.
MicroActive is a trademark of Micromeritics Instrument Corporation.
Micromeritics is a registered trademark of Micromeritics Instrument Corporation.
Microsoft and Windows are registered trademarks of Microsoft Corporation.
Python is a registered trademark of Python Software Foundation.
Silcolloy is a trademark of SilcoTek.
SilcoTek is a trademark of SilcoTek.
Teflon is a registered trademark of E. I. DuPont de Nemours Company.
Viton is a registered trademark of E. I. DuPont Co., Inc.

This application may contain a binary form of the Info-ZIP tool to create .zip files. That source code is provided under the following license:

This software is provided "as is," without warranty of any kind, express or implied. In no event shall Info-ZIP or its contributors be held liable for any direct, indirect, incidental, special or consequential damages arising out of the use of or inability to use this software.

Permission is granted to anyone to use this software for any purpose, including commercial applications, and to alter it and redistribute it freely, subject to the following restrictions:

1. Redistributions of source code must retain the above copyright notice, definition, disclaimer, and this list of conditions.
2. Redistributions in binary form must reproduce the above copyright notice, definition, disclaimer, and this list of conditions in documentation and/or other materials provided with the distribution.
3. Altered versions — including, but not limited to, ports to new operating systems, existing ports with new graphical interfaces, and dynamic, shared, or static library versions — must be plainly marked as such and must not be misrepresented as being the original source. Such altered versions also must not be misrepresented as being Info-ZIP releases — including, but not limited to, labeling of the altered versions with the names "Info-ZIP" (or any variation thereof, including, but not limited to, different capitalizations), "Pocket UnZip," "WiZ" or "MacZip" without the explicit permission of Info-ZIP. Such altered versions are further prohibited from misrepresentative use of the Zip-Bugs or Info-ZIP e-mail addresses or of the Info-ZIP URL(s).
4. Info-ZIP retains the right to use the names "Info-ZIP," "Zip," "UnZip," "WiZ," "Pocket UnZip," "Pocket Zip," and "MacZip" for its own source and binary releases.

Copyright

The software described in this manual is furnished under a license agreement and may be used or copied only in accordance with the terms of the agreement.

WARRANTY

MICROMERITICS INSTRUMENT CORPORATION warrants for one year from the date of shipment each instrument it manufactures to be free from defects in material and workmanship impairing its usefulness under normal use and service conditions except as noted herein.

Our liability under this warranty is limited to repair, servicing and adjustment, free of charge at our plant, of any instrument or defective parts when returned prepaid to us and which our examination discloses to have been defective. The purchaser is responsible for all transportation charges involving the shipment of materials for warranty repairs. Failure of any instrument or product due to operator error, improper installation, unauthorized repair or alteration, failure of utilities, or environmental contamination will not constitute a warranty claim. The materials of construction used in MICROMERITICS instruments and other products were chosen after extensive testing and experience for their reliability and durability. However, these materials cannot be totally guaranteed against wear and/or decomposition by chemical action (corrosion) as a result of normal use.

Repair parts are warranted to be free from defects in material and workmanship for 90 days from the date of shipment.

No instrument or product shall be returned to MICROMERITICS prior to notification of alleged defect and authorization to return the instrument or product. All repairs or replacements are made subject to factory inspection of returned parts.

MICROMERITICS shall be released from all obligations under its warranty in the event repairs or modifications are made by persons other than its own authorized service personnel unless such work is authorized in writing by MICROMERITICS.

The obligations of this warranty will be limited under the following conditions:

1. Certain products sold by MICROMERITICS are the products of reputable manufacturers, sold under their respective brand names or trade names. We, therefore, make no express or implied warranty as to such products. We shall use our best efforts to obtain from the manufacturer, in accordance with his customary practice, the repair or replacement of such of his products that may prove defective in workmanship or materials. Service charges made by such manufacturer are the responsibility of the ultimate purchaser. This states our entire liability in respect to such products, except as an authorized person of MICROMERITICS may otherwise agree to in writing.
2. If an instrument or product is found defective during the warranty period, replacement parts may, at the discretion of MICROMERITICS, be sent to be installed by the purchaser, e.g., printed circuit boards, check valves, seals, etc.
3. Expendable items, e.g., sample tubes, detector source lamps, indicator lamps, fuses, valve plugs (rotor) and stems, seals and O-rings, ferrules, etc., are excluded from this warranty except for manufacturing defects. Such items which perform satisfactorily during the first 45 days after the date of shipment are assumed to be free of manufacturing defects.

Purchaser agrees to hold MICROMERITICS harmless from any patent infringement action brought against MICROMERITICS if, at the request of the purchaser, MICROMERITICS modifies a standard product or manufactures a special product to the purchaser's specifications.

MICROMERITICS shall not be liable for consequential or other type damages resulting from the use of any of its products other than the liability stated above. This warranty is in lieu of all other warranties, express or implied, including but not limited to, the implied warranties of merchantability or fitness for use.

CORPORATE PROFILE

Micromeritics Instrument Corporation is the world's leading supplier of high-performance systems to characterize particles, powders and porous materials with a focus on physical properties, chemical activity, and flow properties. Our technology portfolio includes: pycnometry, adsorption, dynamic chemisorption, particle size, intrusion porosimetry, powder rheology, and activity testing of catalysts. The company has R&D and manufacturing sites in the USA, UK, and Spain, and direct sales and service operations throughout the Americas, Europe, and Asia. Micromeritics systems are the instruments-of-choice in more than 10,000 laboratories of the world's most innovative companies and prestigious government and academic institutions. Our world-class scientists and responsive support teams enable customer success by applying Micromeritics technology to the most demanding applications. For more information, please visit www.micromeritics.com.

CONTACT US

Micromeritics Instrument Corporation

4356 Communications Drive
Norcross, GA 30093-2901 USA
Phone: 1-770-662-3636
www.Micromeritics.com

Instrument Service or Repair

Phone: 1-770-662-3636
International: Contact your local distributor or call 1-770-662-3636
Service.Helpdesk@Micromeritics.com

Micromeritics Application Support

Support@Micromeritics.com

ABOUT THIS MANUAL

The following can be found on the Micromeritics web page (www.micromeritics.com).

- Calculations document (PDF)
- Error Messages document (PDF)
- Operator Manual (PDF)
- Parts and Accessories

The following symbols or icons indicate safety precautions and/or supplemental information and may appear in this manual:



NOTE — Notes contain important information applicable to the topic.



CAUTION — Cautions contain information to help prevent actions that may damage the analyzer or components.



WARNING — Warnings contain information to help prevent actions that may cause personal injury.

Table of Contents

| | |
|--|--------------|
| About this Manual | iv |
| 1 Analyzer Components | 1 - n |
| Equipment Options and Upgrades | 1 - n |
| Gas Requirements and Purity | 1 - n |
| Specifications for the AutoChem II 2920 | 1 - n |
| 2 About the Software | 2 - 1 |
| Peak Editor for Dynamic Analysis | 2 - 1 |
| Software Setup | 2 - 2 |
| Software Updates | 2 - 2 |
| Software Uninstall | 2 - 2 |
| Menu Structure | 2 - 3 |
| Common Fields and Buttons | 2 - 4 |
| File Status, Description, and Location | 2 - 7 |
| Keyboard Shortcuts | 2 - 8 |
| Option Presentation | 2 - 9 |
| Libraries | 2 - 11 |
| Configure the Analyzer | 2 - 12 |
| Environmental Defaults for TCD Analyzers | 2 - 12 |
| Gas Connections | 2 - 13 |
| Unit Selection | 2 - 13 |
| Unit Configuration | 2 - 14 |
| Instrument Status | 2 - 16 |
| Show Instrument Schematic | 2 - 16 |
| Show Status | 2 - 21 |
| Show Instrument Log | 2 - 22 |
| Methods | 2 - 23 |
| Export Files | 2 - 24 |
| List Files | 2 - 25 |
| Analysis Types for TCD Analyzers | 2 - 26 |

| | |
|--|--------------|
| Additional Uses of the TCD Analyzer | 2 - 27 |
| Applications | 2 - 28 |
| 3 Sample Files | 3 - 1 |
| Sample Files | 3 - 2 |
| Open a Sample File | 3 - 4 |
| Active Metals for Chemisorption Analyzers | 3 - 5 |
| 4 Parameter Files | 4 - 1 |
| Adsorptive Properties | 4 - 2 |
| Analysis Conditions | 4 - 4 |
| Insert Experiment Steps | 4 - 7 |
| Report Options | 4 - 21 |
| 5 Perform an Analysis | 5 - 1 |
| Analysis Temperature Guidelines for All Analysis Types | 5 - 1 |
| Cooling Options | 5 - 2 |
| Dewar Precautions | 5 - 3 |
| For Glass Dewars | 5 - 3 |
| Mixing an IPA/LN2 Slurry | 5 - 4 |
| Protect Detector Filaments by Flowing Gas | 5 - 4 |
| Prepare for Analysis | 5 - 5 |
| Clean and Label Sample Tubes | 5 - 5 |
| Prepare the Sample | 5 - 7 |
| Create the Sample File | 5 - 7 |
| Determine the Sample Mass for Chemisorption | 5 - 8 |
| Sample Tube Installation | 5 - 10 |
| Fill and Install the Dewar | 5 - 11 |
| Perform a Sample Analysis | 5 - 12 |
| Reset the Analysis | 5 - 14 |
| 6 About Reports | 6 - 1 |
| Interactive Reports | 6 - 2 |

| | |
|---|--------------|
| MicroActive Reports | 6 - 2 |
| Peak Editor | 6 - 3 |
| Report Features and Shortcuts | 6 - 10 |
| Graph Features and Shortcuts | 6 - 14 |
| Report Examples for AutoChem Analyzers | 6 - 18 |
| First Order Kinetics Report | 6 - 18 |
| Signal vs. Temperature Report | 6 - 19 |
| Signal vs. Time Report | 6 - 20 |
| Summary Report | 6 - 21 |
| 7 Selected Reports | 7 - 1 |
| Advanced Reports - Python Module | 7 - 1 |
| BET Surface Area Report | 7 - 3 |
| First Order Kinetics Report | 7 - 4 |
| Graph Report Options | 7 - 5 |
| Langmuir Report | 7 - 7 |
| Loop Calibration Report | 7 - 8 |
| Options Report | 7 - 8 |
| Options Report | 7 - 11 |
| Pulse Chemisorption Report | 7 - 12 |
| Summary Report | 7 - 14 |
| Total Pore Volume Report | 7 - 15 |
| 8 Calibration | 8 - 1 |
| Gas Concentration Calibration | 8 - 3 |
| Gas Flow Calibration | 8 - 6 |
| Signal Calibration for Dynamic Analysis | 8 - 7 |
| Vapor Calibration | 8 - 12 |
| Load Calibration from File | 8 - 15 |
| Save Calibration to File | 8 - 15 |
| 9 Hardware | 9 - 1 |
| Cold Trap Tube or Delay Path | 9 - 1 |

| | |
|---|---------------|
| Furnace | 9 - 5 |
| KwikCool | 9 - 9 |
| KwikCool Vortex Installation | 9 - 10 |
| Mass Flow Controller Calibration | 9 - 11 |
| Flow Measurement | 9 - 11 |
| Install a Soap Bubble Burette or Other Type of Flow Meter | 9 - 12 |
| Determine the Gas Flow Constant for Individual Gases | 9 - 13 |
| Sample Thermocouple | 9 - 14 |
| Thermocouple Position | 9 - 14 |
| Determine the length of the thermocouple | 9 - 18 |
| Use the Thermocouple Clamp | 9 - 21 |
| Recalibrate the Sample Thermocouple | 9 - 22 |
| Sample Tube | 9 - 24 |
| Sample Tube Installation | 9 - 24 |
| Sample Tube Removal | 9 - 26 |
| Sample Tube Filter or O-ring Replacement | 9 - 27 |
| Septum | 9 - 28 |
| Septum Replacement | 9 - 30 |
| Vapor Generator Installation | 9 - 31 |
| Clean the Vapor Generator | 9 - 32 |
| 10 Troubleshooting | 10 - 1 |
| Enable Manual Control | 10 - 4 |
| Foam Air Filter Replacement | 10 - 5 |
| Guidelines for Connecting Gases | 10 - 8 |
| Replace a Gas Cylinder | 10 - 9 |
| O-ring Compatibility | 10 - 13 |
| Preventive Maintenance | 10 - 14 |
| Check and Clean the Dewar | 10 - 15 |
| Clean the Instrument | 10 - 16 |
| Power Instrument On and Off | 10 - 17 |
| Perform a Leak Test | 10 - 18 |
| Preparation Gas Path Leak Test | 10 - 19 |

| | |
|---|---------------|
| Reference Gas Path Leak Test | 10 - 19 |
| Carrier Gas Path Leak Test | 10 - 20 |
| Vapor Generator Gas Path Leak Test | 10 - 21 |
| Loop Gas Path Leak Test | 10 - 22 |
| Purge the System | 10 - 23 |
| Change the Gas Flow During an Analysis | 10 - 25 |
| Recover from a Power Failure | 10 - 25 |
| Replace the Injection Loop | 10 - 26 |
| TCD Assembly | 10 - 30 |
| Replace the TCD assembly | 10 - 30 |
| Clean the TCD Assembly | 10 - 32 |
| 11 Analysis Tutorials | 11 - 1 |
| BET Surface Area Analysis | 11 - 1 |
| Loop Calibration for TCD Analyzers Tutorial | 11 - 10 |
| Pulse Chemisorption Analysis Tutorial | 11 - 12 |
| Temperature Programmed Desorption Analysis | 11 - 20 |
| Temperature Programmed Oxidation Analysis | 11 - 26 |
| Temperature Programmed Reduction Analysis | 11 - 32 |
| A Advanced Reports - Python Module | A - 1 |
| Advanced Reports | A - 1 |
| Scripts | A - 3 |
| Python Reports | A - 4 |
| Acquire Basic Information | A - 8 |
| Enable the Use of Overlay Data | A - 10 |
| MicModule Python Calls | A - 11 |
| Tables | A - 11 |
| Summary Reports | A - 13 |
| Graphic Reports | A - 14 |
| Get Experiment Information | A - 17 |
| Get Sample Information Item | A - 19 |
| Get Imported Pore Data | A - 20 |

| | |
|---|--------------|
| Get Metal Composition for Chemisorption | A - 21 |
| B Atomic Weights and Cross-Sectional Areas | B - 1 |
| C Auxiliary Inputs and Outputs | C - 1 |
| Output signals: | C - 4 |
| Input signals: | C - 5 |
| D Exported Data Example | D - 1 |
| E Gas Charts | E - 1 |
| F Peak Detection / Integration Options | F - 1 |
| G Temperature Programmed Analyses | G - 1 |
| H Worksheets | H - 1 |
| AutoChem Gas Connections Worksheet | H - 2 |
| Gas Flow Constant Calibration Worksheet | H - 3 |
| Manual Injections Worksheet for AutoChem | H - 5 |
| Sample Data Worksheet for Chemisorption | H - 6 |

1 ANALYZER COMPONENTS

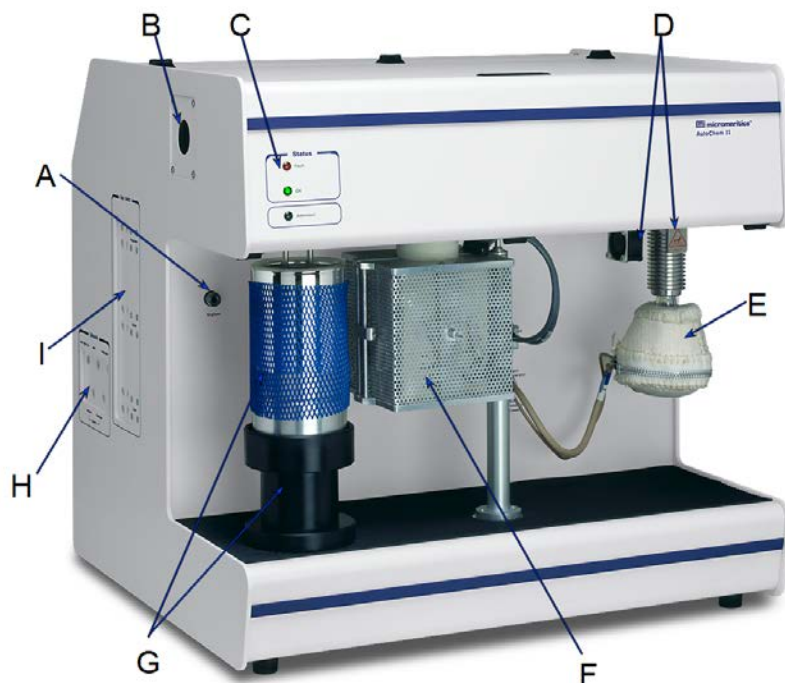

- A. Septum port
- B. Mass spectrometer port
- C. LED lights
- D. Vapor generator and fan
- E. Heating Mantle
- F. Furnace
- G. Dewar and Dewar stand
- H. Gas exhaust ports
- I. Gas inlet ports

| Component | Description |
|------------------------------|--|
| Dewar and Dewar stand | Dewar and Dewar stand. |
| Furnace | Controls the temperature of the sample. |
| Gas exhaust ports | For attachment of appropriate exhaust systems to meet local safety standards for chemisorption exhaust. |
| Gas inlet ports | For preparation, carrier, and loop gases. |
| Heating mantle | For use with an optional vapor generator. |
| LED lights | <p>Indicates the communication between the analyzer and the computer.</p> <ul style="list-style-type: none"> ■ Red - Indicates a fault. Illuminates when there is no communication with the computer. When the analyzer application is exited, the red and the Attention! LED illuminate. ■ Green - Indicates normal communication. ■ Attention! - When blinking, indicates that operator attention is required. Check the computer monitor for instructions. This light blinks if a <i>Wait</i> step requiring operator action was included in the experiment steps. After performing the requested action, click OK. The blinking |

| Component | Description |
|--------------------------------|--|
| | stops. |
| Mass spectrometer port | To attach an optional mass spectrometer. |
| Septum port | To inject gas into an analysis. |
| Vapor generator and fan | Allows analysis using vapors from liquids carried by an inert gas. |

EQUIPMENT OPTIONS AND UPGRADES

Parts and accessories are located on the [Micromeritics](#) web page.

| Option | Description |
|------------------------|--|
| CryoCooler | <p>Analyses can be started at sub-ambient temperatures. The CryoCooler can be used to speed throughput by ramping the furnace temperature rapidly to ambient after an analysis.</p> <p>CryoCooler II - LN₂ cooler. For use with all AutoChem instruments.</p> <p>CryoCooler III - Norhof CryoCooler. For use on the AutoChem II 2920 and AutoChem III only.</p> |
| KwikCool | <p>The standard version ramps the furnace temperature rapidly to near ambient, reducing analysis time and increasing throughput. The Vortex KwikCool version uses compressed air to chill the air for cooling without a Dewar.</p> |
| MKS Cirrus 3 | <p>Connects directly to a dedicated port for detection and identification of low concentrations of condensable and/or reactive gases.</p> |
| Vapor Generator | <p>Allows an inert carrier gas, such as helium, to be bubbled through the liquid at up to 100 °C. The vapor then passes through a cooler condensation zone maintained at an accurate temperature to ensure a stable vapor pressure. The vapor then passes to the loop valve zone (Fill/Inject valve) for precise injections onto the sample.</p> |

GAS REQUIREMENTS AND PURITY



Improper handling, disposing of, or transporting potentially hazardous materials can cause serious bodily harm or damage to the instrument. Always refer to the SDS when handling hazardous materials. Safe operation and handling of the instrument, supplies, and accessories are the responsibility of the operator.

Compressed gases are required for analyses. Gas cylinders or an outlet from a central source should be located near the analyzer.

Appropriate two-stage regulators which have been leak-checked and specially cleaned are required. Pressure relief valves should be set to no more than 30 psig (200 kPag). All gases should be of a purity listed below. Gas regulators can be ordered from Micromeritics. Parts and accessories are located on the [Micromeritics](#) web page.

SPECIFICATIONS FOR THE AUTOCHEM II 2920

Electrical

| | |
|----------------------|-------------------------|
| Voltage | 85 to 265V~ |
| Power | 1250 VA, operating, max |
| Frequency | 50-60 Hz |
| Overvoltage category | II |

Temperature System

| | |
|------------|--|
| Range | -100 °C to 1100 °C with CryoCooler option Ambient to 1100 °C without CryoCooler option |
| Selection | Digitally set, 1 °C increments |
| Ramp Rates | Up to 100 °C per minute from -100 °C to 800 °C Up to 50 °C per minute to 1000 °C Up to 25 °C per minute to 1200 °C |

Gases

| | |
|-----------------|---|
| Loop (Analysis) | H ₂ , CO, O ₂ , N ₂ O, NH ₂ vapors such as pyridine, water, etc |
| Carrier | He, Ar, and other gases |
| Preparation | H ₂ , O ₂ , He, Ar, and others |

Gas Flow Rate

| | |
|----------------------------------|----------------------------------|
| All Mass Flow Controllers (MFCs) | |
| Manual Control | 1 to 100 mL/minute ¹⁾ |
| Automatic Analysis | 10 to 75 mL/minute |

¹⁾ Rate for Nitrogen; other gases have a different range.

Gases

| | |
|-----------------|---|
| Loop (Analysis) | H ₂ , CO, O ₂ , N ₂ O, NH ₂ vapors such as pyridine, water, etc |
| Carrier | He, Ar, and other gases |
| Preparation | H ₂ , O ₂ , He, Ar, and others |

Gas Delivery

| | |
|---------------------|---|
| Inlet Ports | (18), 6 each for preparation gas, carrier gas and loop (analysis) gas |
| Temperature Control | Internal gas lines and valves heated up to 150 °C |

Sample Tube

| | |
|------|--|
| Type | Fused quartz Flow-Thru sample tubes, for use up to 1200 °C, accepts powders and pellets up to 9 mm in diameter |
|------|--|

Physical

| | |
|--------|-------------------|
| Height | 62 cm (24.5 in.) |
| Width | 66 cm (26 in.) |
| Depth | 58 cm (22.75 in.) |
| Weight | 60 kg (130 lbs) |

Environment

| | |
|-----------------------|--|
| Temperature | 15 °C to 35 °C operating, 0 °C to 50 °C non-operating |
| Humidity | 20 to 80% relative, non-condensing |
| Indoor or outdoor use | Indoor only Altitude: 2000 m max Pollution degree of the intended environment: 2 |

Computer Requirements

| | |
|---------------------------------------|--|
| Operating System | Windows 10 or higher operating system is required. |
| Desktop Installation Required | The application should not be installed on a network drive with shared access. |
| | Multiple users cannot operate the application at the same time. |
| 10 Base T or 100 Base T Ethernet Port |  Ensure the "Sleep" setting on the desktop is set to "Never" to avoid interruption while running an analysis. If this occurs, the application loses network connectivity with the instrument and a communications error will be reported. A restart of the Windows application may be required if automatic reconnection is not successful. |
| | If the computer is to be connected to a network, two Ethernet ports are required. If more than one Ethernet-based unit is connected to the same computer, an Ethernet switch will also be required. |
| Read/Write Permissions | All application users will need Read/Write permission to all directories and subdirectories where the application is installed. |
| Drives | USB port |

Due to continuous improvements, specifications are subject to change without notice.

**This page
intentionally
left blank**

2 ABOUT THE SOFTWARE

The analyzer allows other computer programs to run while an automatic operation is in progress. The *Help* menu provides access to the online operator manual.

Report options can be specified when creating the sample file. When running an analysis, data gathered during the analysis process are compiled into predefined reports. Reports can also be defined and generated after an analysis has been run. Each selected report is displayed on its own tab and reflects data collected during the analysis.

The MicroActive feature offers a Windows interface with an easy way to collect, organize, archive, reduce raw data, and store sample files for later use. Scalable and editable graphs and copy and paste graphics are easily generated. Customized reports can be viewed on a computer monitor, printed, or exported for use in other programs.

In addition to customizable standard reports, user-defined calculations and reports can be created through the Advanced reports feature (using Python).

Data can be manipulated and displayed interactively using MicroActive reports.

PEAK EDITOR FOR DYNAMIC ANALYSIS

[*Peak Editor on page 6 - 3*](#)

The TCD (Thermal Conductivity Detector) features a Peak Editor, which allows the evaluation of results, peak editing, and reports. Adjusting peak boundaries can be used to eliminate baseline noise or other undesirable effects. The Peak Editor also allows the separation of composite peaks.

SOFTWARE SETUP



If the computer is to be connected to a network, a second Ethernet port on the computer must be used for that purpose.

The *Setup* program is located on the installation media and is used to reinstall the software and make analyzer changes — such as adding, moving, or removing a unit, etc.



If the IP address needs to be changed on the computer connected to the analyzer, refer to the computer's operating system manual or the internet for instructions. The IP address for the computer and the IP address specified in the setup program must match. The IP address must be 192.168.77.100.

SOFTWARE UPDATES



A User Account Control in the Windows operating system must be enabled to ensure all components of the Micromeritics application are correctly installed. If UAC is not enabled, right-click the *setup.exe* installer file and select *Run as administrator*.

The most current version of the instrument software can be found on the Micromeritics web page (www.micromeritics.com).

When performing a software update, existing data files are not overwritten.

Insert the setup media into the media drive. The setup program starts automatically. If the program does not start automatically, navigate to the installation media drive, locate and double-click the *setup.exe* file.

SOFTWARE UNINSTALL

The software can be uninstalled in two ways. Either method removes only the files required to run the software, not the analysis files.

- Click the Windows *Start* icon. Scroll to the Micromeritics entry. Select the *Uninstall [analyzer]* option, then follow the prompts.
- Locate the *uninstall.exe* file in *C:\Program Files (x86)\Micromeritics\[analyzer name]* (or wherever the application was installed). Double-click the *uninstall.exe* file, then follow the screen prompts.

MENU STRUCTURE

All program functions use standard Windows menu functionality. The title bar contains a *Unit [n]*. If multiple analyzers are installed, ensure the appropriate unit is selected before continuing.

Main Menu Bar Options

| Selections | Description |
|-------------------|--|
| File | Use to manage files used by the application — such as sample files, analysis conditions files, report options files, etc. |
| Unit [n] | Use to perform analyses, calibrations, and other analyzer operations. <i>Unit [n]</i> displays on the menu bar for each analyzer attached to the computer. |
| Reports | Use to start or initiate reports and view the results. |
| Options | Use to change presentation options, set the method and active metals defaults, configure signal calibration, manage libraries, select units, and create report styles. |
| Window | Use to manage open windows and display a list of open windows. A checkmark appears to the left of the active window. |
| Help | Use to access the embedded operator manual, Micromeritics web page, and information about the application. |

COMMON FIELDS AND BUTTONS

The fields and buttons in the following table are located in multiple windows throughout the analyzer application and have the same description or function. Fields and button descriptions not listed in this table are found in tables in their respective sections. All entry fields will accept information when using a bar code reader.

Common Fields and Buttons

| Selections | Description |
|--|--|
| Add | Adds an item to the list. |
| Add Log Entry | Use to enter information that will display in the sample log report that cannot be recorded automatically through the application. Click the button again to enter multiple log entries. |
| Append | Use to insert one row at the end of a table. |
| Autoscale | When enabled on report parameters windows, allows the x- and y-axes to be scaled automatically. <i>Autoscale</i> means that the x- and y- ranges will be set to show all the data. If <i>Autoscale</i> is not selected, the entered range is used. |
| Axis Range | On report parameters windows, the <i>From / To</i> fields are enabled when <i>Autoscale</i> options are not selected. Enter the starting and ending values for the x- and/or y-axes. |
| Bar Code (default field label name) | Use to enter additional information about the sample, such as a sample lot number, sample ID, etc. |
| Browse | Searches for a file. |
| Cancel | Discards any changes or cancels the current process. |
| Clear | Use to clear the table entries and display only one default value. |
| Close | Closes the active window and displays a prompt to either accept or reject changes. |
| Close All | Closes all active windows. If changes were made and not yet saved, a prompt displays for each changed file providing the option to save the file. |
| Comments | Enter comments to display in the report header about the sample or analysis. |
| Copies | Selects the number of copies to print. This field is only enabled when <i>Print</i> is selected. |
| Delete | When working with tables, deletes the selected information. |
| Destination | Selects the report destination. |

Common Fields and Buttons (continued)

| Selections | Description |
|------------------|---|
| Edit | When working with report parameters, highlight the item in the <i>Selected Reports</i> list box and click Edit to modify the report details. |
| Exit | Exits the application. If a file is open with unsaved changes, a prompt displays the option to save the changes and exit or exit the application without saving the changes. If an analyzer is currently operating, an additional prompt displays to confirm exiting from the software. |
| Export | Exports data in a sample file as a .TXT, .XML or .XLS file. When saved to a file, the data can be imported into other applications. |
| File | Selects the destination directory. Enter a new file name in the <i>File name</i> field or accept the default. Select to save the file as a spreadsheet (.XLS), a portable document format (.PDF), or an ASCII text (.TXT) file format. |
| File name | Selects a file name from the list shown or enter a file name. If the required file type is not shown, select the type of file from the list. |
| From / To | Indicates the <i>From</i> and <i>To</i> range for x- and/or y-axes when working with report parameters windows. |
| Insert | Inserts one row above the selected row in the table. |
| List | Creates a list of samples or other types of files. The list will contain the file name, date/time the file was created or last edited, file identification, and file status. |
| Name | Contains a list of files in the selected directory or library. |
| Next | Moves to the next window or next step. |
| OK | Saves and closes the active window. |
| Open | Opens the selected file. Alternatively, double-click the file name in the Name column to open the file. |
| Prev | Moves to the previous window. |
| Preview | Previews predefined reports. Click the tabs at the top of the window to preview each selected report. When an analysis has not been run on a sample, this button is disabled. |
| Print | Sends the report to the selected destination (screen, printer, or file). |
| Remove | Removes the selected file or files from the list. |
| Replace | Selects another file where the values will replace the current file's values. |

Common Fields and Buttons (continued)

| Selections | Description |
|--------------------|--|
| Replace All | Selects another .SMP file where the values will replace all values for the active sample file. The original file will remain unchanged. No analysis data is added to the file. The only information added is sample information, material properties, liquid properties, analysis, and reporting parameters. |
| Report | Displays a window to specify report output options. |
| Save | Saves changes. |
| Save As | Saves a file in the active window under a different file name. A portion can be saved as a separate, stand-alone file, such as Analysis Conditions or Report Options, when saving sample information. |
| Start | Starts the report, test, analysis, or operation. |
| Start Date | Displays a calendar to select the start date for the report. |
| View | <p>Operation. Displays the data from the current analysis.</p> <p>Instrument Log. Displays recent analyses, calibrations, errors, or messages. Enabled only in Service Test Mode.</p> <p>Instrument Schematic. Displays a schematic of the analyzer system.</p> |

FILE STATUS, DESCRIPTION, AND LOCATION

In the *File Selector* window, the *Mic Description* column and the *Mic Status* column display the file description and file status. The *File Selector* incorporates standard Windows features for resizing windows, reordering and repositioning columns, and right-clicking an entry to display a menu of standard Windows functions.

File Status

| File Status | Description |
|-------------|--|
| Analyzing | Sample files that are currently used for analysis. |
| Complete | Sample files used in an analysis that is completed. |
| No Analysis | Sample files that have not been used to perform an analysis. |

File Type and File Name Extension

| File Type | File Name Extension |
|---------------------|---------------------|
| Analysis Conditions | .ANC |
| Methods | .MTH |
| Report Options | .RPO |
| Sample Information | .SMP |
| SPC Report | .SPC |

File Types for Printing or Exporting

| File Type | File Name Extension |
|----------------------------|---------------------|
| Portable document format | .PDF |
| Report | .REP |
| Spreadsheet | .XLS |
| Unicode | .TXT |
| Extensible markup language | .XML |

KEYBOARD SHORTCUTS

Shortcut keys can be used to activate some menu commands. Shortcut keys or key combinations (when applicable) are listed to the right of the menu item.

Certain menus or functions can also be accessed using the **Alt** key plus the underlined letter in the menu command. For example, to access the *File* menu, press **Alt + F**, then press the underlined letter on the submenu (such as pressing **Alt + F**) then pressing **O** to open the *File Selector*).



If the underscore does not display beneath the letter on the menu or window, press the **Alt** key on the keyboard.

Keyboard Shortcuts

| Selections | Description |
|-----------------------|--|
| Alt + [Unit n] | Opens the <i>Unit [n]</i> menu. |
| Alt + F4 | Exits the program. If files are open with unsaved changes, a prompt to save changes displays. |
| Alt + H | Opens the <i>Help</i> menu. |
| Alt + I | Opens the <i>Options</i> menu. |
| Alt + R | Opens the <i>Reports</i> menu. |
| Alt + W | Opens the <i>Window</i> menu. |
| Ctrl + N | Opens a new sample file. |
| Ctrl + O | Opens the <i>File Selector</i> window. |
| Ctrl + P | Opens the <i>File Selector</i> to start a report from a selected .SMP file. |
| Ctrl + S | Saves the open file. |
| F1 | Opens the online help operator manual. |
| F2 | Opens the <i>File Selector</i> window. |
| F3 | When in the <i>File Selector</i> window, opens the file search box. |
| F4 | When in the <i>File Selector</i> window, opens the address bar. |
| F6 | Cascades open windows. |
| F7 | Tiles all open application windows. |
| F8 | Opens the <i>File Selector</i> to start a report from a selected .SMP file. |
| F9 | Closes all open reports. |
| Shift + F9 | Opens the shortcut menu of either the selected component on the analyzer schematic when manual control is enabled or the onscreen reports. |

OPTION PRESENTATION

Options > Option Presentation

Use to change the way sample files and parameter files display: *Advanced*, *Basic*, or *Restricted*. Each display option shows sample information and options differently.

Option Presentation Display

| Presentation Display | Description |
|------------------------------|--|
| Advanced | Displays all parts of sample and parameter files. Navigate to parameter windows by selecting the tabs across the top of the window. |
| Basic | Displays sample information in a single window. This display option is used after the parameter files have been created. The previously entered or default parameter files are then accessible using drop-down lists. |
| Restricted | Displays the sample file in a single window like the <i>Basic</i> display option with certain functions disabled. A password is set when the <i>Restricted</i> option is selected. That same password must be entered to change to the <i>Basic</i> or <i>Advanced</i> display option. This display type is typically used in laboratories — such as the pharmaceutical industry — where analysis conditions must remain constant. The <i>Advanced</i> option is not available in the view selector at the bottom of the window when using the <i>Restricted</i> display option. |
| Always Open Edit View | Opens files with a <i>Complete</i> status in the tabbed file editor rather than in the Peak Editor view. |
| Show Splash Screen | Enables (or disables) the splash screen upon application startup. |



To change the view for the selected window, use the drop-down list at the bottom of the sample file editor.

The following examples show the same sample file in *Advanced* and *Basic* display. *Basic* and *Restricted* displays will look the same. A password is required if using *Restricted* format.

Option Presentation Examples



Advanced view

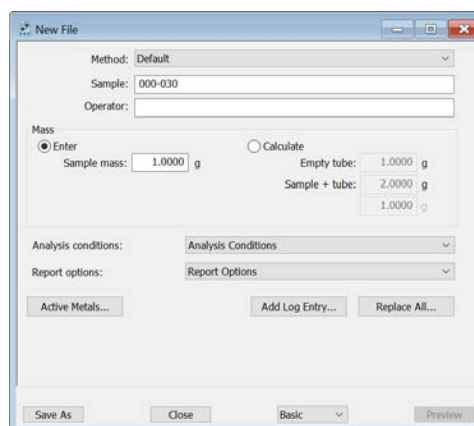

Basic or Restricted view



A sample file must be created for each analysis. The file can be created prior to or at the time of analysis. The sample file identifies the sample, guides the analysis, and specifies report options.

LIBRARIES

Options > Manage Libraries



This feature is not available when using *Restricted* option presentation.

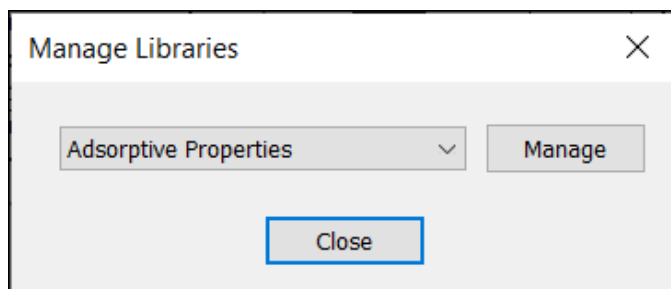

The library provides an easy way to locate and open specific analyzer files. Libraries are located within the *File Selector* window and can be viewed only within the application.

The library gathers sample and parameter files stored in multiple locations, such as folders on a C: drive, a network location, a connected external hard drive, or a connected USB flash drive, and provides access to all files. Even though libraries do not store actual sample and parameter files, folders can be added or removed within each library.

One library can include up to 50 folders. Other items, such as saved searches and search connectors, cannot be included.

When *removing* a folder from a library, the folder and its contents are not deleted from the original file storage location. However, when *deleting* files or folders from within a library, they are deleted from their original file storage location. Deleted files and folders can be recovered from the Recycle Bin located on the Windows desktop.

CONFIGURE THE ANALYZER

ENVIRONMENTAL DEFAULTS FOR TCD ANALYZERS

Options > Environmental Defaults

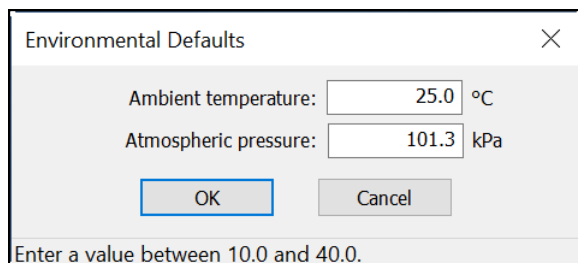

These values are used in some calculations to account for the effect of environmental conditions on the analysis. These parameters are used in the Dynamic Analysis reports. To ensure accurate loop calibration, enter current environmental conditions daily, or whenever there is a significant change in one or more of the environmental conditions.



Saturation pressure (P_o) of the adsorbate used by BET analysis is obtained from the adsorptive properties for the experiment gas specified.

Environmental Defaults

| Selections | Description |
|---|---|
| Ambient temperature [text box] | The temperature of the room where the analyzer is located. |
| Atmospheric pressure [text box] | The atmospheric pressure of the room where the analyzer is located. |



For fields and buttons not listed in this table, see [Common Fields and Buttons on page 2 - 4](#).

GAS CONNECTIONS

Unit [n] > Gas Connections

[Adsorptive Properties on page 4 - 2](#)

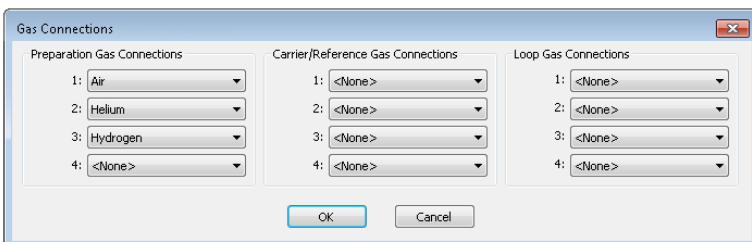

Use to configure the gas type connected to each analysis port. The gases available in the drop-down lists come from the Adsorptive Properties (.ADP) files. Click **OK** when done.

UNIT SELECTION

Options > Units

Use to specify how data should appear on the application windows and reports. This menu option is not available if using *Restricted* option presentation in a standard installation environment.

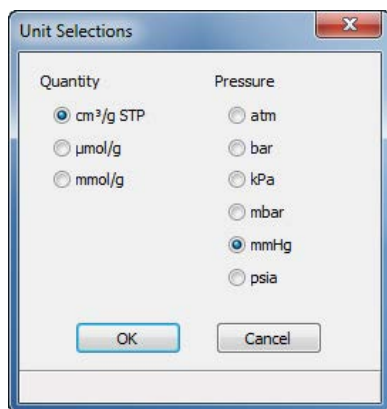

UNIT CONFIGURATION

Unit [n] > Unit Configuration

Use to display and confirm hardware and software configurations and calibrations of the analyzer.

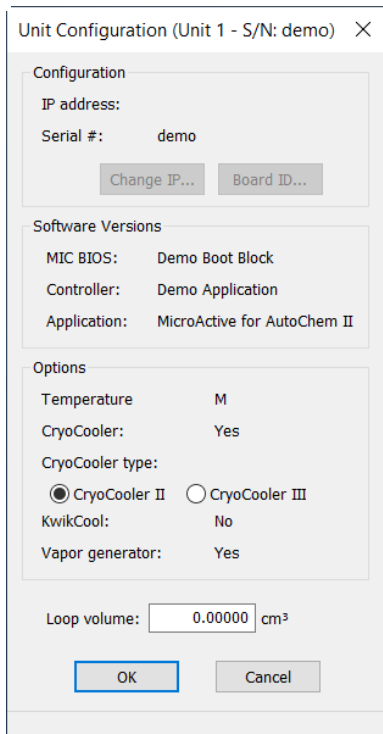

Unit Configuration

| Fields | Description |
|-------------------------------------|---|
| Configuration [group box] | <p>Displays the IP address used by the analysis program, serial number, and type of analyzer.</p> <p>IP address. Displays the IP address of the analyzer.</p> <p>Change IP. [button] Displays the Board ID dialog, which describes the circuit boards in the analyzer. Use the Board drop-down list to select a board to view.</p> <p>Board ID. [button] Click to display information from the circuit boards in the analyzer. Use the drop-down list to select a board to view. The parameters shown cannot be edited.</p> <p>Serial #. Displays the analyzer serial number.</p> |
| Loop volume [text box] | Enter the volume of the gas injection loop. Three standard |

Unit Configuration (continued)

| Fields | Description |
|--|--|
| | volume loops are provided with the analyzer. The loop volume is determined by performing a loop calibration. See Loop Calibration for TCD Analyzers Tutorial on page 11 - 10 . |
| Options [<i>group box</i>] | Displays options installed on the analyzer. For Temperature controller: M — indicates Micromeritics E — indicates Eurothem CryoCooler type: <ul style="list-style-type: none"> ▪ CryoCooler II - (default) LN₂ cooler ▪ CryoCooler III - Norhof CryoCooler |
| Software Versions [<i>group box</i>] | Displays the software versions of the MIC BIOS, controller software, and analysis program. |

INSTRUMENT STATUS

SHOW INSTRUMENT SCHEMATIC

Unit [n] > Enable Manual Control

Unit [n] > Show Instrument Schematic

[Enable Manual Control on page 10 - 4](#)
[Gas Pathways on page 2 - 21](#)

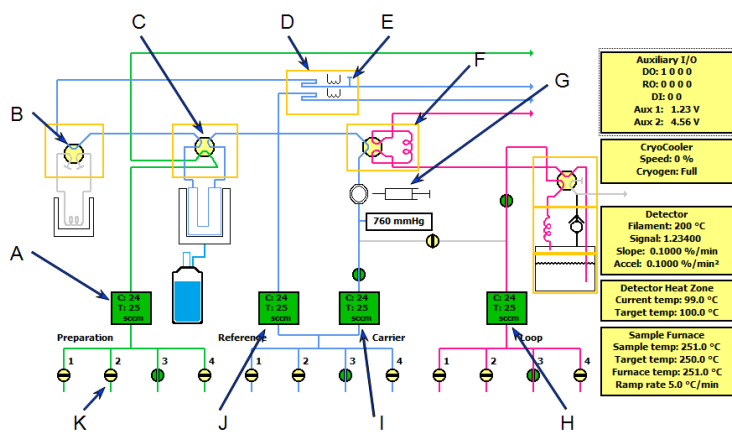



- A. Preparation gas MFC
- B. Cold trap valve heat zone
- C. Analysis heat zone
- D. Detector heat zone
- E. Auxiliary port
- F. Loop valve heat zone
- G. Septum
- H. Loop gas MFC
- I. Carrier gas MFC
- J. Reference gas MFC
- K. Inlet valves



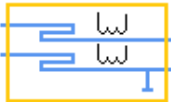
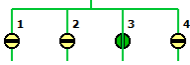

Analyzer Schematic Icons

| Icon or Symbol | Description |
|----------------|--|
| | Auxiliary I/O. Lists the current auxiliary settings for Digital and Relay Output (DO and RO) and Digital Input (DI). The current Auxiliary 1 and Auxiliary 2 signals are also displayed if recorded. See Auxiliary Inputs and Outputs on page C - 1 . |
| | Auxiliary Port. Connect an external detector (such as a mass spectrometer) to the analyzer. It cannot be manually controlled. |
| | Calibration Valves. Used during automatic calibration processes. Generally, it is not necessary to change the state of the calibration valves. |

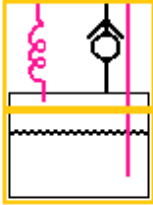

Analyzer Schematic Icons (continued)

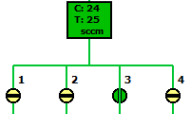
| Icon or Symbol | Description |
|---|--|
|  | <p>Closed Valve. Yellow indicates a closed valve. When manual control is disabled, closed valves appear white.</p> |
|  | <p>CryoCooler. Displays only if installed. The CryoCooler speed can be set from 0 to 100%.</p> <div data-bbox="594 495 974 760" style="border: 1px solid gray; padding: 5px; margin: 10px 0;"> <p>Set CryoCooler ×</p> <p>Motor speed: <input type="text" value="20"/> %</p> <p style="text-align: center;"> <input type="button" value="OK"/> <input type="button" value="Cancel"/> </p> <p style="font-size: small;">Enter a value between 0 and 100.</p> </div> <p>Blue. Indicates the Dewar is full</p> <p>Red. Indicates the Dewar is empty. When the rate speed is set to 100%, the Dewar displays as red and empty, a warning light illuminates, and the pump will beep continuously.</p> <p>Yellow. Indicates Dewar level is unknown and rate is set to zero (for CryoCooler III installations only).</p> |
|  | <p>Detector Heat Zone. Set the detector heat zone by clicking anywhere in the orange box. Set the Filament Temperature by clicking the detector rectangle on the right side of the schematic.</p> <div data-bbox="594 1222 980 1528" style="border: 1px solid gray; padding: 5px; margin: 10px 0;"> <p>Set Detector ×</p> <p><input checked="" type="checkbox"/> Enable detector</p> <p>Filament temperature: <input type="text" value="245"/> °C</p> <p style="text-align: center;"> <input type="button" value="OK"/> <input type="button" value="Cancel"/> </p> </div> |
|  | <p>Gas Inlet Valves. The inlet displays the gas mnemonic if one is assigned. Right-click the inlet valve to open or close the valve.</p> |

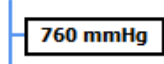

Analyzer Schematic Icons (continued)

| Icon or Symbol | Description |
|---|---|
|  | <p>Heat Zones. Controls the temperature of various parts of the analyzer. Component heat zones are enclosed with an orange rectangle. Click a heat zone icon to display the current temperature and the target temperature. Right-click the icon, then select <i>Set Temperature</i> to change the heat zone's target temperature. Using the default temperature (110 °C) for all heat zones is recommended to ensure a cleaner system.</p> <p>The cold trap heat zone controls the temperature of the cold trap valve.</p> |
|  | <p>KwikCool. Displays only if installed.</p> |
|  | <p>Mass Flow Controller. Controls the flow of gas into the analyzer. The MFC target and flow rate are displayed. Right-click and select an option:</p> <ul style="list-style-type: none"> ▪ Open. Fully opens the MFC. ▪ Close. Closes the MFC to stop gas flow. ▪ Set. Displays the applicable Mass Flow Controller dialog box in which you can open the controller, close the controller, or set the flow rate. <div data-bbox="626 1304 1008 1562" style="border: 1px solid black; padding: 5px; margin: 10px 0;"> <p style="text-align: center; font-size: small;">Set Reference Mass Flow Controller ✕</p> <p><input type="radio"/> Open</p> <p><input type="radio"/> Close</p> <p><input checked="" type="radio"/> Set flow rate: <input style="width: 50px;" type="text" value="10.00"/> sccm</p> <p>Gas: N2</p> <p style="text-align: center;"> <input type="button" value="OK"/> <input type="button" value="Cancel"/> </p> </div> <ul style="list-style-type: none"> ▪ Zero. Sets the MFC to read zero flow under current conditions. |
|  | <p>Open Valve. Green indicates an open valve.</p> |

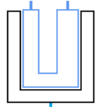
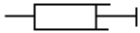
Analyzer Schematic Icons (continued)

| Icon or Symbol | Description |
|---|--|
|  | <p>Pressure Transducer. Displays the current pressure in the carrier gas path, upstream from the septum but downstream from the Mass Flow Controller. It cannot be manually controlled.</p> |
|  | <p>Rotary Valve. Controls the gas flow through the cold trap, sample tube, loop, and optional vapor generator. Select the needed state. From left to right, the valves and their states are:</p> <ul style="list-style-type: none"> ▪ Cold Trap. Bypass, Trap ▪ Analysis. Analyze, Prepare ▪ Loop. Fill, Inject ▪ Vapor. Vapor, Bypass (optional) |
|  | <p>Sample Furnace. Controls the temperature of the sample. Click to display the sample temperature, the target temperature, the furnace temperature, and the ramp rate. Right-click the icon and select <i>Set Temperature</i> to change the <i>Set Point</i> and/or the <i>Ramp Rate</i>.</p> |
|  | <p>Septum. Makes manual injections of gas into the gas stream.</p> |

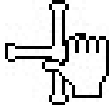
Schematic Shortcuts

| Icon or Symbol | Description |
|---|--|
| Valve options  | Close. Closes the selected valve. Open. Opens the selected valve. |
| Temperature control options  | Select <i>Set Temperature</i> to modify furnace or heater settings. |

Gas Pathways

The colored lines that lead from the gas inlets through the analyzer and to the exhaust represent the current flow path. A different color path represents each gas source:

| | |
|-------|-----------------------------|
| Pink | Loop gas |
| Blue | Carrier and Reference gases |
| Green | Preparation gas |
| Black | Blended gas |



When a gas valve is opened, or the flow path is changed, it takes several minutes for the new gas to move through the entire system.

The behavior of the loop valve is one example. When an analysis includes a loop injection, the schematic shows the path available in *Fill* mode, then *Inject* mode.

- In *Fill* mode, the analysis gas enters the loop, and the excess gas vents out the exhaust.
- In *Inject* mode, the analysis gas bypasses the loop and exits the analyzer through the exhaust.

At that time, the carrier gas path is available from the inlet all the way through the loop, through the sample tube, and past the detector.

When the valve switches to *Inject* mode, the quantity of analysis gas contained in the loop — one exact unit — is pushed out of the loop and through the sample tube by the carrier gas. When the application is recording the TCD signal, the loop injection shows as a peak on the *Results* view of the *Analysis* window.

The analysis gas may be greatly dissipated as it travels out of the loop and through the sample tube, particularly if the carrier gas flow rate is low. Higher carrier gas flow rates minimize the dispersion of the loop gas.

SHOW STATUS

Use to show the current status for each port.

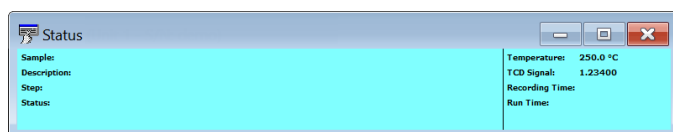

If multiple units are attached to the computer, select *Show Status* on each *Unit [n]* menu. The status for all units displays.

SHOW INSTRUMENT LOG

Unit [n] > Show Instrument Log

Use to display a log of recent analyses, calibrations, errors, or messages.

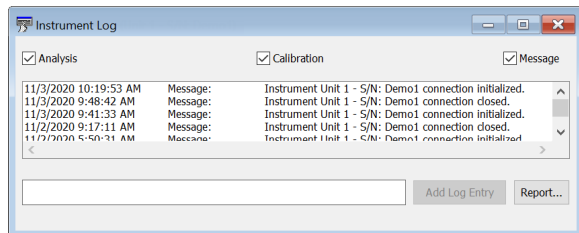

Instrument Log

| Selections | Description |
|--|--|
| Add Log Entry [button] | Use to enter information to appear in the sample log report that cannot be recorded automatically through the application. Click the button again to enter multiple log entries. |
| Analysis/ Calibration/ Message [checkbox] | Select the logs to display. |
| Report [button] | Click to select the print destination and the report start date. |
|  For fields and buttons not listed in this table, see Common Fields and Buttons on page 2 - 4. | |

METHODS

Options > Default Method

File > Open > [.MTH File]

A *Method* determines the default sample identification format and sequence number. A *Method* is a template of specifications that go into a newly created sample file. It allows for the definition of complete sets of parameters for each type of sample commonly analyzed. Only a single selection is required for each new sample file created.

The *Method* drop-down list displays only those methods applicable to the open sample file type.

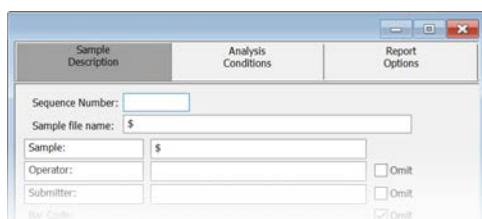

Default Method Examples

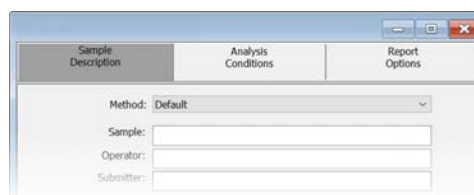

Default Method Examples

Default Methods

| Selections | Description |
|--|--|
| Sample file name [text box] | Enter a format for the sample identification. The entry in this field becomes a part of the saved sample file name. Include the \$ symbol to have the sample file number included as part of the identification. |
| Sample Operator Submitter Bar Code [text box] | These field labels may be renamed, and the new label becomes a part of all new sample files. |
| Sequence number [text box] | Specify a default numeric string to use as a prefix in the <i>Sample</i> field when a new sample file is created. This number increments with each sample file created. |

EXPORT FILES

File > Export

[Exported Data Example on page D - 1](#)

Provides the option to print the contents of one or more sample or parameter files to either the screen, a printer, or a file. Data can be exported as a .PDF, .TXT, .XML, or .XLS file format. The type of data to include or exclude can be selected during the export process. The data can be imported into other applications that read these file formats when exported to a file.

1. Click **List** and open an .SMP file.
2. Select an experiment and the applicable options.
3. Click **OK**.

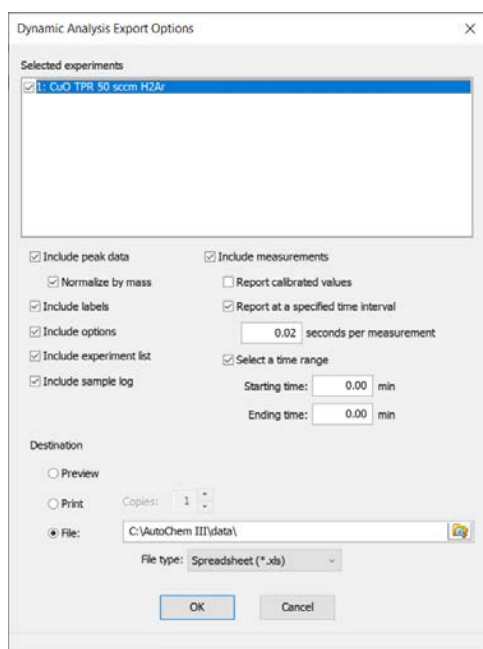

LIST FILES

File > List

Provides the option to create a list of sample file information —such as file name, date, time the file was created or last edited, file identification, and file status.

Select one or more files from the file selector, click **List**, then provide the file destination.

| No. | File Name | File Listing | | Description | Status |
|-----|--|--------------|------------|--|----------|
| | | Date | Time | | |
| 1 | 13x with CO2 at 0C Port 1B.SMP | 8/10/2020 | 3:53:54 PM | 13x with CO2 Port 1 | Complete |
| 2 | 13x with CO2 at 0C Port 2B.SMP | 8/10/2020 | 3:53:54 PM | 13x with CO2 Port 2 | Complete |
| 3 | 13x with CO2 at 0C Port 3B.SMP | 8/10/2020 | 3:53:54 PM | 13x with CO2 Port 3 | Complete |
| 4 | 13x with N2 and TranSeal Port 2.SMP | 8/10/2020 | 3:53:54 PM | 13X Zeol Tube 2 w/ FS @ end of analysis, Port 2 | Complete |
| 5 | 13x with N2 and TranSeal Port 3.SMP | 8/10/2020 | 3:53:54 PM | 13X Zeol Tube 1A w/ FS @ end of analysis, Port 3 | Complete |
| 6 | Activated Carbon with Butane C3 Port 1.SMP | 8/10/2020 | 3:53:55 PM | Activated Carbon Tube C3 Butane Port 1 | Complete |
| 7 | Activated Carbon with Butane C4 Port 3.SMP | 8/10/2020 | 3:53:55 PM | Activated Carbon Tube C4 Butane Port 3 | Complete |

**Example of
File List**

ANALYSIS TYPES FOR TCD ANALYZERS

The basic concept for all analyses is the same: the filament detects changes in the gas mixture flowing past it. The sample, gas selection, and analysis conditions determine what changes occur.

[*BET Surface Area Analysis on page 11 - 1*](#)

[*Pulse Chemisorption Analysis Tutorial on page 11 - 12*](#)

[*Temperature Programmed Desorption Analysis on page 11 - 20*](#)

[*Temperature Programmed Oxidation Analysis on page 11 - 26*](#)

[*Temperature Programmed Reduction Analysis on page 11 - 32*](#)

The BET surface area analysis evaluates the total surface area of the catalyst before and after chemisorption. Pore-plugging phenomena, which might occur due to the irreversible adsorbed species during chemical reactions, and the occurrence of sintering¹), can be studied.

After outgassing the sample, a mixture of nitrogen and helium (typically 5 to 30% N₂) flows over the sample that is immersed in a liquid nitrogen (LN₂) bath. Both the adsorption and desorption of the N₂ are recorded. The amount of nitrogen desorbed at LN₂ temperatures and the sample weight is used to calculate the total specific surface area.

The entire BET analysis — or even repeat analyses — is performed in situ.

- **Langmuir Surface Area** Analysis. The Langmuir surface area analysis allows for evaluating the total surface area of the catalyst and is especially useful for adsorbate/adsorbent systems that adsorb only a monolayer. These materials typically exhibit a Type 1 isotherm and are often microporous. The Langmuir surface area analysis may be best applied to zeolites and microporous carbons. Typically the Langmuir surface area will exceed the BET surface area for these materials and provide a more accurate estimation of the total surface area. The Langmuir surface area report may be applied to a wide range of gas concentrations and is not limited to the typical BET range (5 to 30% N₂).

¹) Sintering is the fusing of small particles (or small features of a sample). Sintering tends to reduce the active surface area.

- **Total Pore Volume Analysis.** The total pore volume is a single-point estimate of the pore capacity of a material. The total pore volume analysis is usually conducted near the saturation pressure of the adsorbate (0.995 P/P₀). The total pore volume of a material can be determined on both fresh and used materials. The difference in pore volume may indicate pore plugging and directly relate to changes in the performance of catalysts and adsorbents.

For a high surface area sample (> 100 m²/g), a quantity less than 50 mg is recommended. The high sensitivity combined with a large amount of adsorbed gas allows smaller sample quantities to be used while maintaining high precision. The reduced sample quantity will also reduce the likelihood of saturating the high sensitivity detector.

ADDITIONAL USES OF THE TCD ANALYZER

The analyzer may also be used for temperature programmed reactions, catalyst pretreatment, and isothermal reactions. The tremendous flexibility of the analyzer allows the use of custom applications.

Temperature Programmed Reaction

A temperature programmed reaction monitors the products from the reaction between gases and a catalyst at a specified temperature. The analyzer can be programmed to raise the temperature of a catalyst bed at a constant ramping rate as the gases flow through the catalyst. At the optimal temperature, the gases react in the presence of the catalyst, creating products. The products of the reaction and excess reactants can be diverted to a gas chromatograph or to a mass spectrometer to be analyzed.

Catalyst Pretreatment

Catalyst pretreatment usually consists of activating a catalyst before its use in a chemical reaction. For example, a temperature programmed oxidation reaction may require reduction of the catalyst under a flow of H₂ at a specific temperature.

Isothermal Reaction

An isothermal reaction is similar to a temperature programmed reaction except that the catalyst is kept at a constant temperature (isothermal) to perform the catalytic reaction. Both the product of the reaction and the excess reactants can be diverted to a gas chromatograph or to a mass spectrometer to be analyzed.

APPLICATIONS

Catalytic processes that benefit from TPD/TPR analyses include:

- Polymerization
- Hydrogenation
- Catalyst cracking
- Hydrocracking
- Isomerization
- Oxidation
- Dehydrogenation
- Hydrotreating
- Alkylation reforming

3 SAMPLE FILES

Sample files include the information required by the analyzer to perform analyses and collect data. A sample file identifies the sample, guides the analysis, specifies report options, and may be displayed in *Advanced*, *Basic*, or *Restricted* presentation display mode. After data is collected, the file is shown in MicroActive mode or the tabbed file editor.

A sample file consists of parameter sets; however, parameter sets can also stand alone. A sample file may be created either before or at the time of analysis.

Parameter files allow for repeated use of parameter sets. For example, if the same analysis conditions exist for multiple analyses, an *Analysis Conditions* file containing the recurring conditions can be created. When the sample file is created, the *Analysis Conditions* file can be selected for the analysis conditions. Once it becomes part of the new sample file, the new file can be edited, as needed, without affecting the original *Analysis Conditions* file.

The analysis application contains a default method. A method is a template for sample files that contains the parameters to be used for an analysis. When a new sample file is created, all the parameters are filled with the values in the default method.



To change the view for the selected window, use the drop-down list at the bottom of the sample file editor.

SAMPLE FILES

File > New Sample > [.SMP File]

File > Open > [.SMP File]



Analysis condition defaults for metal stoichiometry factors can be set using the sample information metal table editor. Stoichiometry factors can also be set for each pulse chemisorption experiment using the analysis conditions experiment step editor. If required, stoichiometry factors for a completed pulse chemisorption experiment can be viewed and modified using the peak editor's stoichiometry settings window.

Each analysis must be linked with a sample file before the analysis can proceed. A sample file can consist of parameter files; however, parameter files can also stand alone.

Specify or change the option presentation by selecting **Options > Option Presentation** or use the view selector drop-down list at the bottom of the window.

Sample files created in the *Basic* option presentation are selected from parameter files created in the *Advanced* option presentation. The values specified in the parameter portions of the default method are the defaults for new sample files. To navigate from one set of parameters to another, select the parameter tab across the top of the window.



**Advanced
option presentation**

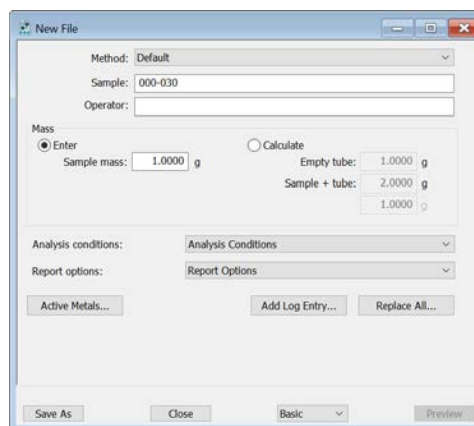

**Basic or Restricted
option presentation**

Sample Files

| Selections | Description |
|--|---|
| Active Metals [button] | Displays a list of active metals. See Active Metals for Chemisorption Analyzers on page 3 - 5 . |
| Add Log Entry [button] | Use to enter information that will display in the sample log report that cannot be recorded automatically through the application. Click the button again to enter multiple log entries. |
| Bar Code [text box] | Use to enter additional information about the sample, such as a sample lot number, sample ID, etc. |
| Comments [text box] | Enter comments to display in the report header about the sample or analysis. |
| Mass [group box] | <p>Enter a value for sample mass. Mass can be changed any time before, during, or after analysis.</p> <p>Enter. Enables the <i>Sample mass</i> field. Enter a value for the sample mass.</p> <p>Calculate. Enables the <i>Empty tube</i> and <i>Sample + tube</i> fields. Enter the values necessary to calculate the sample mass. The equation used to calculate sample mass:</p> $Mass_{sample} = Mass_{sample+tube} - Mass_{tube}$ |
| Method [drop-down box] | Select a method from the drop-down list. |
| Operator [text box] | Enter operator identification information. This field label may have been renamed or may not display if modified in Options > Default Methods . |
| Sample [text box] | Enter a sample description. |
| Submitter [text box] | Enter submitter identification information. This text box may have been renamed or may not display if modified in Options > Default Methods . |
|  <p>For fields and buttons not listed in this table, see Common Fields and Buttons on page 2 - 4.</p> | |

OPEN A SAMPLE FILE

File > Open > [.SMP File]



When working with an existing sample file, consider copying the sample file to maintain the original configuration options.

| File Status | Displays |
|--------------------|--------------------|
| No Analysis | Tabbed file editor |
| Complete Analyzing | Peak Editor view |



**Tabbed file editor in
Advanced view**

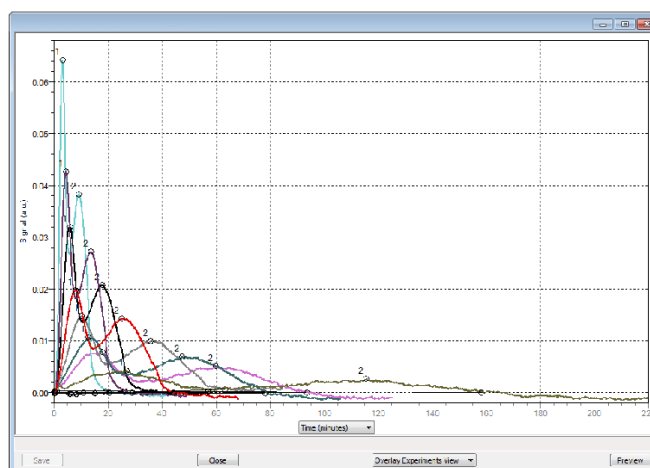

Peak Editor View

To view the tabbed file editor for a sample file with a *Complete* status, select *Advanced* from the view selector drop-down list at the bottom of the window.

ACTIVE METALS FOR CHEMISORPTION ANALYZERS

Options > Active Metals Defaults

Or, click **Active Metals** on the *Sample Description* tab when using the *Advanced* presentation option.

[Atomic Weights and Cross-Sectional Areas on page B - 1](#)

Up to 20 elements can be specified. At least one element must have a non-zero % of the sample weight.

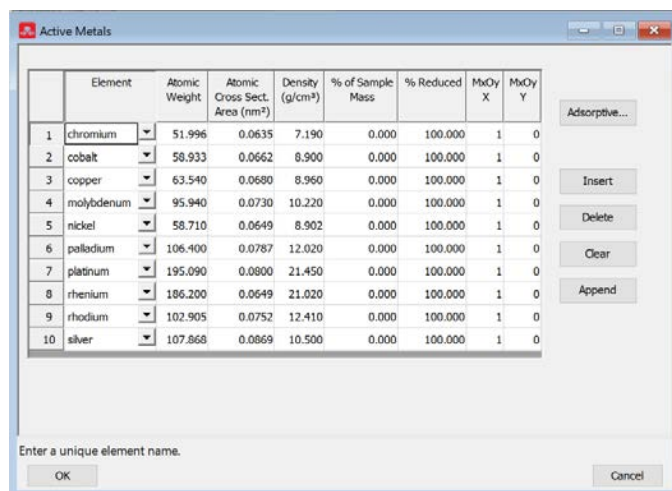

Active Metals

| Selections | Description |
|--------------------------------------|--|
| % of Sample Weight * [column] | Percentage, by weight, of each element contained in the sample. |
| % Reduced * [column] | The percent of metal reduced during preparation. |
| Adsorptive [button] | Click to display and modify both the adsorptives and their associated stoichiometry factor. Stoichiometry factors for each gas are metal-specific. |

Active Metals (continued)

| Selections | Description | | | | | | | | | | | | | | | | | | | | | | | | | | | | | | | | | | | | | | | |
|---|---|----------------------|------------|----------------------|---|----------|-------|---|-----|-------|---|---------|-------|---|----------------|-------|---|--------|-------|---|--------|-------|---|--------|-------|---|--------|-------|---|--------|-------|----|--------|-------|----|--------|-------|----|--------|-------|
| | <div style="border: 1px solid gray; padding: 5px; margin-bottom: 10px;"> <p style="text-align: right; margin: 0;">✕</p> <p style="margin: 0;">Adsorptives for chromium</p> <table border="1" style="width: 100%; border-collapse: collapse;"> <thead> <tr> <th style="width: 5%;"></th> <th style="width: 70%;">Adsorptive</th> <th style="width: 25%;">Stoichiometry Factor</th> </tr> </thead> <tbody> <tr><td>1</td><td>1-Butene</td><td>1.000</td></tr> <tr><td>2</td><td>Air</td><td>1.000</td></tr> <tr><td>3</td><td>Ammonia</td><td>1.000</td></tr> <tr><td>4</td><td>Carbon Dioxide</td><td>1.000</td></tr> <tr><td>5</td><td><None></td><td>1.000</td></tr> <tr><td>6</td><td><None></td><td>1.000</td></tr> <tr><td>7</td><td><None></td><td>1.000</td></tr> <tr><td>8</td><td><None></td><td>1.000</td></tr> <tr><td>9</td><td><None></td><td>1.000</td></tr> <tr><td>10</td><td><None></td><td>1.000</td></tr> <tr><td>11</td><td><None></td><td>1.000</td></tr> <tr><td>12</td><td><None></td><td>1.000</td></tr> </tbody> </table> <p style="text-align: center; margin-top: 10px;"> <input type="button" value="OK"/> <input type="button" value="Cancel"/> </p> </div> <p>Stoichiometry Factor. The stoichiometry factor is defined as the moles of metal species covered per mole of adsorptive.</p> | | Adsorptive | Stoichiometry Factor | 1 | 1-Butene | 1.000 | 2 | Air | 1.000 | 3 | Ammonia | 1.000 | 4 | Carbon Dioxide | 1.000 | 5 | <None> | 1.000 | 6 | <None> | 1.000 | 7 | <None> | 1.000 | 8 | <None> | 1.000 | 9 | <None> | 1.000 | 10 | <None> | 1.000 | 11 | <None> | 1.000 | 12 | <None> | 1.000 |
| | Adsorptive | Stoichiometry Factor | | | | | | | | | | | | | | | | | | | | | | | | | | | | | | | | | | | | | | |
| 1 | 1-Butene | 1.000 | | | | | | | | | | | | | | | | | | | | | | | | | | | | | | | | | | | | | | |
| 2 | Air | 1.000 | | | | | | | | | | | | | | | | | | | | | | | | | | | | | | | | | | | | | | |
| 3 | Ammonia | 1.000 | | | | | | | | | | | | | | | | | | | | | | | | | | | | | | | | | | | | | | |
| 4 | Carbon Dioxide | 1.000 | | | | | | | | | | | | | | | | | | | | | | | | | | | | | | | | | | | | | | |
| 5 | <None> | 1.000 | | | | | | | | | | | | | | | | | | | | | | | | | | | | | | | | | | | | | | |
| 6 | <None> | 1.000 | | | | | | | | | | | | | | | | | | | | | | | | | | | | | | | | | | | | | | |
| 7 | <None> | 1.000 | | | | | | | | | | | | | | | | | | | | | | | | | | | | | | | | | | | | | | |
| 8 | <None> | 1.000 | | | | | | | | | | | | | | | | | | | | | | | | | | | | | | | | | | | | | | |
| 9 | <None> | 1.000 | | | | | | | | | | | | | | | | | | | | | | | | | | | | | | | | | | | | | | |
| 10 | <None> | 1.000 | | | | | | | | | | | | | | | | | | | | | | | | | | | | | | | | | | | | | | |
| 11 | <None> | 1.000 | | | | | | | | | | | | | | | | | | | | | | | | | | | | | | | | | | | | | | |
| 12 | <None> | 1.000 | | | | | | | | | | | | | | | | | | | | | | | | | | | | | | | | | | | | | | |
| Atomic Cross Sect. Area (nm²) [column] | Atomic cross-sectional area of the element. | | | | | | | | | | | | | | | | | | | | | | | | | | | | | | | | | | | | | | | |
| Atomic Weight [column] | Atomic weight of the element. | | | | | | | | | | | | | | | | | | | | | | | | | | | | | | | | | | | | | | | |
| Density g/cm³ [column] | Density of the element. | | | | | | | | | | | | | | | | | | | | | | | | | | | | | | | | | | | | | | | |
| Element [drop-down box] | Select or enter the active metal. | | | | | | | | | | | | | | | | | | | | | | | | | | | | | | | | | | | | | | | |
| MxOy, X * MxOy, Y * [column] | X and Y values specify the empirical formula for metal and oxygen, respectively, in a metal oxide. | | | | | | | | | | | | | | | | | | | | | | | | | | | | | | | | | | | | | | | |
|  | <p>For fields and buttons not listed in this table, see Common Fields and Buttons on page 2 - 4.</p> | | | | | | | | | | | | | | | | | | | | | | | | | | | | | | | | | | | | | | | |

* Options are shown only when using the **Active Metals** button on the *Sample Description* tab.

4 PARAMETER FILES

Parameter files allow for repeated use of parameter sets. For example, if the same analysis conditions exist for multiple analyses, an *Analysis Conditions* file containing the recurring conditions can be created. When the sample file is created, the *Analysis Conditions* file can be selected for the analysis conditions. Once it becomes part of the new sample file, the new file can be edited, as needed, without affecting the original *Analysis Conditions* file.

Methods include both analysis conditions and report options, offering the most convenient way to repeat most analyses.

Predefined parameter files are included with the program and can be edited as needed, or new parameter files created.

The following file types can exist as part of the sample file as well as individual parameter files.

Parameter File Types

| File Type | File Extension |
|-----------------------|----------------|
| Adsorptive Properties | .ADP |
| Analysis Conditions | .ANC |
| Method | .MTH |
| Report Options | .RPO |

ADSORPTIVE PROPERTIES

File > Open > [.ADP File]

[Gas Connections on page 2 - 13](#)

[Gas Charts on page E - 1](#)

Adsorptive properties provide the adsorptive (analysis gas) characteristics for the analysis.

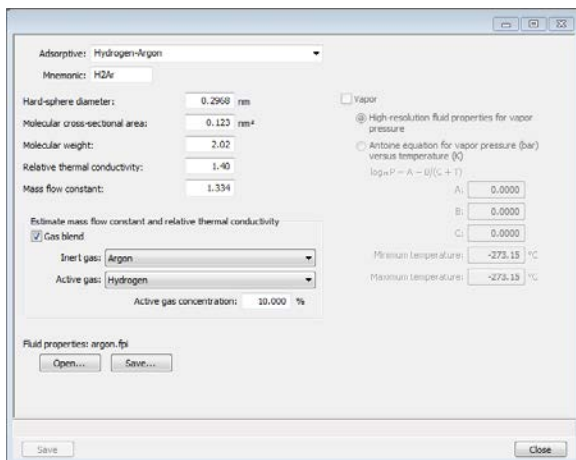

Adsorptive Properties

| Selections | Description |
|---|--|
| Adsorptive [drop-down box] | Name of the adsorptive gas whose properties are being defined. |
| Estimate mass flow constant and thermal conductivity [group box] | Select if a gas blend will be used for the estimated Relative Thermal Conductivity and Mass Flow Constant. Select the gases to be used in the blend. Gas blend. [check box] Select to specify a preblended mixture of a chemically inert gas and a chemically active gas. The blend's <i>Mass Flow Constant</i> and <i>Relative Thermal Conductivity</i> are automatically calculated from those for the two gases in the blend. |
| Fluid properties [button] | Use to import parameters from a Fluid Properties (.FPI) file. Changing fluid properties should only be necessary if an adsorptive is to be used for which no adsorptive properties are provided. Contact Micromeritics Scientific Services if new fluid properties are required. |
| Hard-sphere diameter [text box] | Estimate of the molecular size used in calculating the thermal transpiration correction. |

Adsorptive Properties (continued)

| Selections | Description |
|--|---|
| Mass flow constant [text box] | Scaling factor for the Mass Flow Controller measured flow rate. Applicable only for the gas used in the flow prep tasks. The default is preset for gases provided with the application. |
| Mnemonic [text box] | Enter the mnemonic name for the adsorptive. |
| Molecular cross-sectional area [text box] | The area that a single adsorbed molecule occupies on the surface of the sample. It is used in surface area calculations. |
| Molecular weight [text box] | The molecular mass is used for the weight % column of the isotherm tabular report and the pressure composition isotherm plot. |
| Relative thermal conductivity [text box] | Enter the thermal conductivity relative to Air. |
| Vapor [check box] | <p>Select if vapor is going to be used and enter the vapor defaults.</p> <p>High-resolution fluid properties. Use to import parameters from a Fluid Properties (.FPI) file. Changing fluid properties should only be necessary if an adsorptive is to be used for which no adsorptive properties are provided. Contact Micromeritics Scientific Services if new fluid properties are required.</p> <p>Antoine equation. Enter the Antoine constants.</p> <ul style="list-style-type: none"> ▪ A, B, C. Enter the Antoine constants used in the vapor TCD calibration. ▪ Min/Max temperature. Enter the temperature range where the constants are valid. |
|  <p>For fields and buttons not listed in this table, see Common Fields and Buttons on page 2 - 4.</p> | |

ANALYSIS CONDITIONS

[Insert Experiment Steps on page 4 - 7](#)

File > Open > [.ANC File]

Analysis conditions specify the parameters used to guide an analysis.



When inserting experiments, select the instrument type in the *View conditions for* drop-down list.

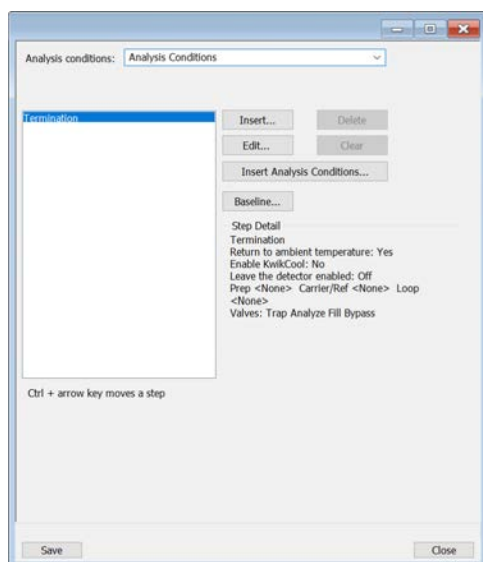

Analysis Conditions

| Selections | Description |
|---|--|
| Analysis Conditions [drop-down box] | Use to browse for an <i>Analysis Conditions</i> file that contains analysis condition parameters to be used in the analysis. |

Analysis Conditions (continued)

| Selections | Description |
|-----------------------------------|--|
| Baseline [<i>button</i>] | <p>Specifies baseline settings if a <i>Wait</i> step depends upon the <i>Baseline</i>.</p> <div style="border: 1px solid gray; padding: 5px; margin: 10px 0;"> <p style="text-align: center; font-size: small;">Baseline Detection Parameters ×</p> <p>Stable Baseline A "stable baseline" is detected when the signal's slope is below the threshold for the indicated duration.</p> <p>Slope threshold: <input type="text" value="0.010"/> %/min Duration: <input type="text" value="5.00"/> min</p> <p>Change From Baseline A "change from baseline" is detected when the signal's acceleration exceeds the threshold for the indicated duration.</p> <p>Acceleration threshold: <input type="text" value="0.200"/> %/min² Duration: <input type="text" value="0.10"/> min</p> <p>Return To Baseline A "return to baseline" is detected when the signal's acceleration falls below the threshold for the indicated duration.</p> <p>Acceleration threshold: <input type="text" value="0.050"/> %/min² Duration: <input type="text" value="1.00"/> min</p> <p style="text-align: center;"> <input type="button" value="OK"/> <input type="button" value="Cancel"/> </p> <p style="font-size: x-small;">Enter a value between 0.001 and 10.000.</p> </div> <p>Establishes the <i>Slope</i> or <i>Acceleration</i> threshold and <i>Duration</i> for determining what constitutes a <i>Stable Baseline</i>, a <i>Change From Baseline</i>, and a <i>Return To Baseline</i>. These values control whether a particular change in the signal is significant to the current experiment — such as defining a stable baseline.</p> <p>Some <i>Wait</i> steps are contingent upon the values selected — such as if the experiment contains a <i>Wait until Baseline is stable</i> step, the signal is compared to these values to determine if a stable baseline has been established. Lower slope/acceleration values and longer durations create a more rigorous definition of these factors than higher values and shorter durations.</p> <p>Stable Baseline. [<i>group box</i>] Detected when the signal slope is below the threshold for the indicated duration.</p> <p>Change from Baseline. [<i>group box</i>] Detected when the signal acceleration exceeds the threshold for the indicated duration.</p> <p>Return to Baseline. [<i>group box</i>] Detected when the signal acceleration falls below the threshold for the indicated duration.</p> |

Analysis Conditions (continued)

| Selections | Description |
|--|--|
| Delete [<i>button</i>] | Deletes the currently selected step. If the step is an experiment, a prompt displays to confirm deletion of all steps for that experiment. |
| Edit [<i>button</i>] | Displays the applicable dialog box for the selected step. |
| Insert [<i>button</i>] | <p>Inserts a new step into the task list.</p> <p>To ensure safe operation and reliable results, a chemically inert gas flow should be inserted between flows of two chemically reactive gases such as hydrogen and oxygen.</p> |
| Insert Analysis Conditions [<i>button</i>] | Loads an entire list of steps, baseline parameters, and peaks parameters from the selected dynamic analysis conditions file. |
| Step Detail [<i>group box</i>] | Displays summary information about the highlighted experiment step. |
| View conditions for [<i>drop-down box</i>] | Selects the instrument model to use, and the editor only shows the options available for that model. The selection is saved and reused when the file is reopened and disabled during and after analysis. |
|  <p>For fields and buttons not listed in this table, see Common Fields and Buttons on page 2 - 4.</p> | |

INSERT EXPERIMENT STEPS

Experiments can be customized to control the analysis reaction. When an experiment is inserted, the initial conditions are specified first, then the individual steps. On the *Analysis Conditions* tab, click **Insert** to insert an experiment. Select the experiment step in the box, then click **Edit** to modify settings. An analysis set is created by inserting up to 99 experiments in the sample file.

To edit steps that have not been started, the analysis must be suspended.

- Upcoming steps - display as black or blue
- Current step - step is highlighted and displays as light blue
- Completed steps - display as light green



The *DDE Command* step and *Wait for synchronization message* option in the Wait step are no longer supported.

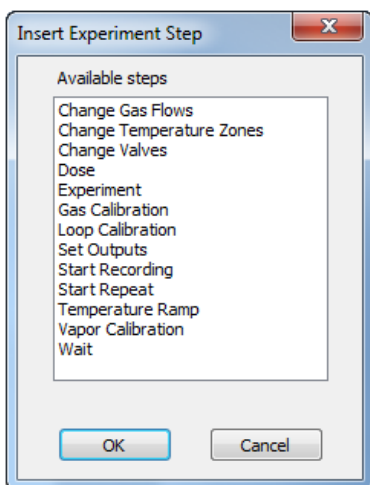

Data from one experiment are not available for editing until the next experiment in the analysis has begun recording.

Experiment Fields

| Selections | Description |
|----------------------|--------------------------------------|
| Change Valves | Sets the rotary valves as specified. |

Experiment Fields (continued)

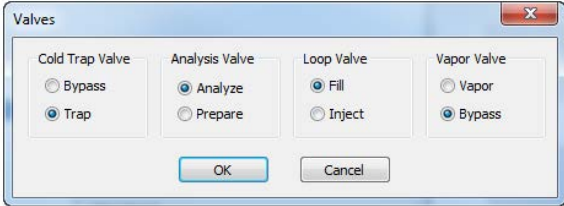
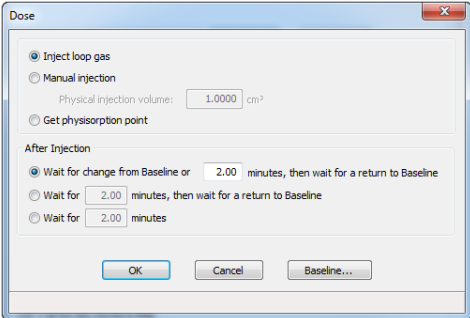
| Selections | Description |
|------------|---|
| |  |
| Dose |  <p>Injection Type:</p> <ul style="list-style-type: none"> ■ Inject loop gas. Automatically injects the contents of the loop into the path that leads to the sample. The contents of the loop are pushed out of the loop by the carrier gas. ■ Manual injection. Prompts the user to inject a dose of gas into the septum using a syringe. ■ Get physisorption point. Provides a series of steps necessary to collect data for a physisorption point. These steps include placing a Dewar of liquid nitrogen around the sample tube, waiting for a return to baseline, then replacing the Dewar with water at room temperature. Repeated points can be taken by placing the <i>Dose</i> step within a <i>Repeat Loop</i>. <p>After Injection. Specify the conditions for completion of this step.</p> <p>Baseline. See <i>Baseline</i> button in Analysis Conditions on page 4 - 4.</p> |

Experiment Fields (continued)

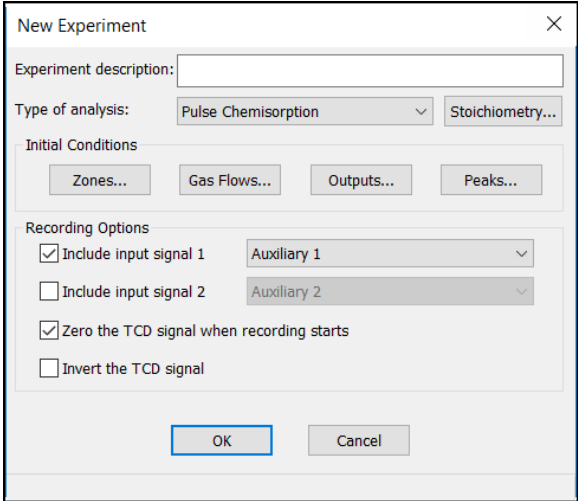
| Selections | Description |
|-------------------|--|
| Experiment |  <p>Experiment description. Description of the experiment.</p> <p>Type of analysis. See Analysis Types for TCD Analyzers on page 2 - 26. If <i>Pulse Chemisorption</i> is selected, the Stoichiometry button is enabled. When modifying the <i>Active Metals</i> table during the insertion of a <i>Pulse Chemisorption</i> experiment, changes to the <i>Active Metals</i> table on the <i>Sample Description</i> tab are not affected. This is useful when sequencing multiple experiments and Stoichiometry is different from one experiment to the next.</p> <p>Initial Conditions. Description for Zones, Gas Flows, Outputs, and Peaks buttons are provided elsewhere in this table.</p> <p>Stoichiometry. Opens the <i>Active Metals</i> table. Specify the percent of sample weight of the active metals in the sample and the stoichiometry factor. See Active Metals for Chemisorption Analyzers on page 3 - 5.</p> |

Experiment Fields (continued)

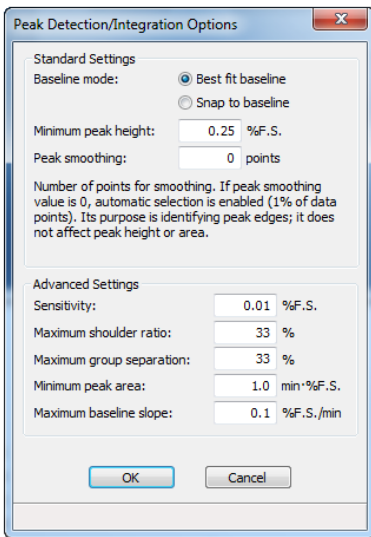
| Selections | Description |
|------------|---|
| | <div data-bbox="509 300 602 405">  </div> <p data-bbox="646 310 1385 594">Analysis condition defaults for metal stoichiometry factors can be set using the sample information metal table editor. Stoichiometry factors can also be set for each pulse chemisorption experiment using the analysis conditions experiment step editor. If required, stoichiometry factors for a completed pulse chemisorption experiment can be viewed and modified using the peak editor's stoichiometry settings window.</p> <p data-bbox="646 625 1070 659">See Peak Editor on page 6 - 3.</p> <hr/> <h3 data-bbox="496 709 763 743">Recording Options</h3> <ul data-bbox="496 787 1409 1115" style="list-style-type: none"> ▪ Include input signal. Allows the use of external electrical input from an auxiliary port or choose to report an analyzer specific parameter from the drop-down list. See Auxiliary Inputs and Outputs on page C - 1. ▪ Zero the TCD signal when recording starts. Zeros the TCD signal automatically the first time recording starts in an experiment. ▪ Invert the TCD signal. Inverts the TCD signal. For example, if only negative peaks are expected, this option can be used to record the peaks in the positive direction. <p data-bbox="496 1134 594 1163">Peaks:</p> <p data-bbox="496 1199 1078 1232">Use to control peak detection during analysis.</p> <div data-bbox="505 1268 873 1801">  <p>The screenshot shows a dialog box titled "Peak Detection/Integration Options". It is divided into two sections: "Standard Settings" and "Advanced Settings".</p> <p>Standard Settings:</p> <ul style="list-style-type: none"> Baseline mode: <input checked="" type="radio"/> Best fit baseline, <input type="radio"/> Snap to baseline Minimum peak height: 0.25 %F.S. Peak smoothing: 0 points <p><small>Number of points for smoothing. If peak smoothing value is 0, automatic selection is enabled (1% of data points). Its purpose is identifying peak edges; it does not affect peak height or area.</small></p> <p>Advanced Settings:</p> <ul style="list-style-type: none"> Sensitivity: 0.01 %F.S. Maximum shoulder ratio: 33 % Maximum group separation: 33 % Minimum peak area: 1.0 min·%F.S. Maximum baseline slope: 0.1 %F.S./min <p>Buttons: OK, Cancel</p> </div> |

Experiment Fields (continued)

| Selections | Description |
|------------------------|---|
| | <p>After analysis, peak detection can be further controlled using the Peak Editor. See Peak Editor on page 6 - 3. The TCD detects and records all deviations from baseline, but only those which satisfy the criteria established in this window are reported as peaks.</p> <hr/> <div style="border: 1px solid green; padding: 5px; display: flex; align-items: center;"> <p>The defaults are usually acceptable. See Peak Detection / Integration Options on page F - 1.</p> </div> |
| Gas Calibration | <div style="border: 1px solid gray; padding: 10px; margin-bottom: 10px;"> </div> <p>Use to calibrate the TCD so that peak area data can be converted to volume data. During a gas calibration, a series of known gas mixtures flows through the analyzer and the resultant signal readings are recorded. The analyzer can then use these data to calculate the concentrations of unknown mixtures flowing past the detector during subsequent analyses.</p> <p>Description. Description of the experiment.</p> <p>Calibration Gases. Select the <i>Carrier</i> and <i>Loop</i> gases to be used in this calibration. The gases available are those specified in an Adsorptive Properties [.ADP] file. See Adsorptive Properties on page 4 - 2 and Gas Charts on page E - 1 for gas combinations.</p> <p>Flow rate. Specify a flow rate for the calibration gases. Typically, the same flow rate is used for both the carrier and reference gas. To use different flows, select <i>Different reference flow</i>.</p> <p>Different reference flow. Use to specify different flows for the calibration gases. When selected, the <i>Rate</i> field is enabled to enter a different flow. This flow is used for the reference gas; the carrier gas uses the <i>Flow Rate</i> field.</p> |

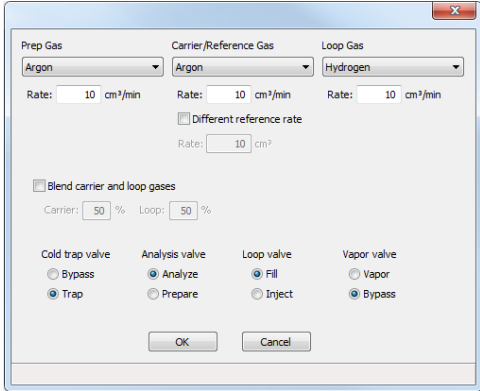

Experiment Fields (continued)

| Selections | Description |
|------------------------|---|
| | <p>The carrier gas flows through the path that contains the sample tube, and through the reference path. The reference path flows directly from the inlet over the reference detector, making it possible for the detector to detect variations in the gas that traveled through the sample tube (carrier) path.</p> <p>Recording Options. See Recording Options on page 4 - 10</p> |
| <p>Gas Flow</p> |  <p>Use to select the gases for this step, specify the flow rates, specify the percent of the carrier gas mixture which is composed of the reactive, and set the state of the rotary valves.</p> <p>The listed gases are those specified in the Adsorptive Properties file. See Adsorptive Properties on page 4 - 2 and Gas Charts on page E - 1 for gas combinations. Select <i>None</i> when no gas is to be flowing (the flow rate is ignored).</p> <p>Prep Gas, Carrier/Reference Gas, Loop Gas. Select the gas for each set of inlet ports. The gases listed are those with defined adsorptive properties. If manual injections are to be programmed, the gas to be injected must be selected as <i>Loop</i> or <i>Injection</i> gas.</p> <p>When an analysis is started, the application verifies that the selected gases are connected to the appropriate ports. If there is a discrepancy between a gas selected for the current sample file and the gases indicated in the <i>Gas Configuration</i> window, an error message is displayed.</p> <p>Rate. The rate at which gas is to flow.</p> <p>Different reference rate. The carrier gas flows through two separate paths through the analyzer — through the path that contains the sample</p> |

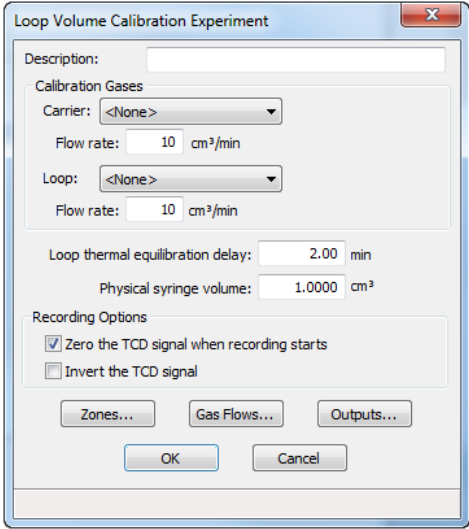
Experiment Fields (continued)

| Selections | Description |
|-------------------------|--|
| | <p>tube, and through the reference path. The reference path flows directly from the inlet over the reference detector, making it possible for the detector to detect variations in the gas that traveled through the sample tube (carrier) path.</p> <p>The same flow rate is typically used for both the carrier and reference gas. To use different flows in these two paths, select <i>Different reference rate</i>, then specify the flow to use for the reference gas path in the <i>Rate</i> field. (The <i>Rate</i> field determines the carrier gas flow rate.)</p> <p>Blend carrier and loop gases. Select to have the carrier and loop gases blended then enter the percentage for the gases. Whichever field is modified, the other field automatically defaults to a percentage totaling 100. If this option is selected for a Physisorption experiment, set the correct blended active concentration in the peak editor after analysis completes.</p> <p>Cold trap valve, Analysis valve, Loop valve, Vapor valve, Cold trap valve, Analysis valve, Loop valve, Back pressure valve. Select a status for each valve. If <i>Vapor</i> is selected for the status of the vapor valve and the vapor generator is not attached to the analyzer when the analysis is started, an error message is displayed.</p> |
| Loop Calibration |  <p>Use to verify the volume of the loop for use in calculations on analyses that use the loop. Sample analysis data yield signal vs. temperature data and peak areas. Associating the sample file with a loop calibration file makes it possible for the application to convert sample data to volume values.</p> |

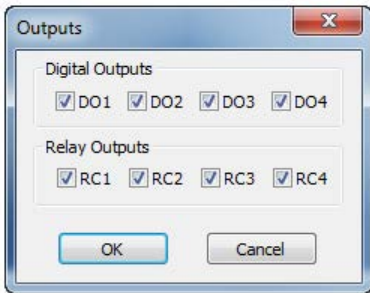
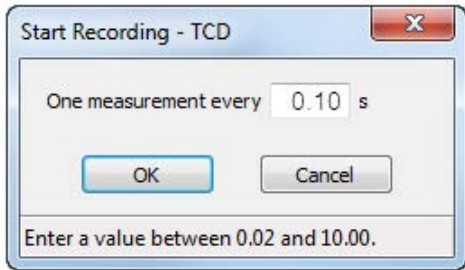
Experiment Fields (continued)

| Selections | Description |
|-----------------|---|
| Outputs | <p>Use to specify the state of the digital and relay outputs.</p>  <p>Ports are provided for connecting auxiliary inputs and outputs. For example, the digital outputs can be used to control a mass spectrometer. See Auxiliary Inputs and Outputs on page C - 1.</p> |
| Start Recording |  <p>Specifies how frequently the signal reading is recorded. A <i>Stop Recording</i> step is inserted in the steps automatically when a <i>Start Recording</i> step is inserted. Multiple steps can be inserted between the <i>Start Recording</i> and <i>Stop Recording</i> steps.</p> <p>One measurement every [n] seconds. [text box] Specify the frequency of measurements.</p> <hr/> <div style="border: 1px solid green; padding: 5px;">  <p>If a <i>Start Recording</i> step is immediately followed by a step that prompts an immediate peak, peak data are recorded before any baseline readings can be collected. To collect some baseline data before the first peak, insert a <i>Wait for [n] minutes</i> step after the <i>Start Recording</i> step but before the step which causes the peak.</p> </div> |

Experiment Fields (continued)

| Selections | Description |
|---------------------|--|
| Start Repeat | <div data-bbox="500 296 1073 663" style="border: 1px solid gray; padding: 5px; margin-bottom: 10px;"> <p style="text-align: right; margin: 0;">×</p> <p>Start Repeat sequence</p> <p><input type="radio"/> Repeat until peaks are equal or <input style="width: 40px;" type="text" value="20"/> times.</p> <p><input type="radio"/> Repeat until peaks are zero or <input style="width: 40px;" type="text" value="20"/> times.</p> <p><input checked="" type="radio"/> Repeat <input style="width: 40px;" type="text" value="20"/> times.</p> <p><input type="radio"/> Repeat until peaks match the first peak or <input style="width: 40px;" type="text" value="20"/> times.</p> <p style="text-align: center; margin-top: 10px;"> <input style="border: 1px solid blue;" type="button" value="OK"/> <input type="button" value="Cancel"/> </p> </div> <p>Specifies the duration of the repeat sequence. Automatically inserts a <i>Start Repeat</i> and a <i>Stop Repeat</i> in the list of steps. Multiple experiment steps can be inserted within the <i>Repeat</i> loop.</p> <p>Repeat until peaks are equal or [n] times. [button] Stops repeating the steps within the loop when the last two peaks are equal to within 5% of the area, or when the maximum number of repeats is reached. This option is useful when performing H₂ or CO pulse chemisorption on supported metal catalysts.</p> <p>Repeat until peaks are zero or [n] times. [button] Stops repeating the steps within the loop when the last two peaks are each less than 10% of the area of the first peak, or when the maximum number of repeats is reached. This option is useful when performing an N₂O decomposition for characterizing copper catalysts.</p> <p>Repeat [n] times. [button] Stops repeating the steps within the loop when the specified number of times is reached.</p> <p>Repeat until peaks match the first peak or [n] times. [button] Stops repeating the steps within the loop when the last two peaks each match the first peak to within 10% of its area or when the maximum number of repeats is reached.</p> |

Experiment Fields (continued)

| Selections | Description |
|------------------|---|
| Temperature Ramp | <div data-bbox="500 296 786 705" data-label="Image"> </div> <p>Changes the sample temperature.</p> <hr/> <div data-bbox="500 821 607 926" data-label="Image"> </div> <p>Temperatures above 850 °C can cause damage to a metal sample tube.</p> <p>Also, sample temperatures significantly above 1100 °C will cause accelerated wear on furnace components and lead to premature failure of the furnace. Experiments should be designed with sample temperatures at or below 1100 °C or to minimize operating time above 1100 °C.</p> <hr/> <p>Ramp Type [group box]:</p> <ul style="list-style-type: none"> ■ Furnace ramp. [button] Ramps the furnace temperature directly to the <i>End</i> temperature ignoring the sample temperature. ■ Sample ramp. [button] Ramps the sample temperature to the <i>End</i> temperature. The actual furnace temperature is adjusted to meet this target. ■ Sample ramp and equilibrate. [button] Ramps the sample temperature to the <i>End Temperature</i> and waits for it to equilibrate before proceeding. ■ Return to ambient. [button] Allows the furnace temperature only (not the sample temperature) to return rapidly to a temperature to below 45 °C. <p>End temperature. [text box] The ending temperature for the ramping procedure. If the CryoCooler is installed, it is automatically enabled if an ending temperature below 20 °C is used.</p> |

Experiment Fields (continued)

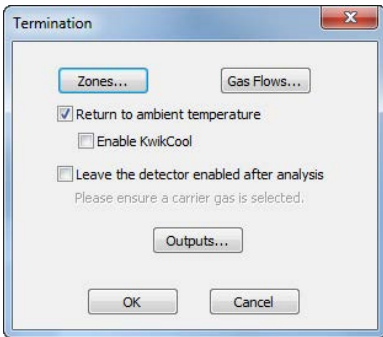
| Selections | Description |
|--------------------|---|
| | <p>Hold time. [text box] Temperature at which the sample is to be held while degassing.</p> <p>Ramp rate. [text box] The rate at which the temperature will change while advancing to the hold temperature.</p> <p>Enable KwikCool. Select to use the KwikCool to reduce the furnace temperature more rapidly during cool down. If selected and the KwikCool is not attached to the analyzer when the analysis is started, an error message is displayed. If the CryoCooler (rather than the KwikCool) is attached, the cool down operation is performed by the CryoCooler.</p> |
| Termination |  <p>Return to ambient temperature. Allows the furnace temperature only (not the sample temperature) to return rapidly to a temperature between 14 °C and 50 °C.</p> <p>Enable KwikCool. See Enable KwikCool in <i>Temperature Ramp</i>.</p> <p>Leave the detector enabled after analysis. Several hours may be required for the analyzer to reach thermal stability after the detector is enabled. This option keeps the detector enabled after analysis, allowing the analyzer to remain stable.</p> <p>Gas flow through the detector is required while the detector is enabled but is not necessary if the detector is disabled. It is recommended to flow an inert gas to continuously purge the system.</p> <p>Should the analysis be canceled due to an analyzer error, the detector will be left enabled if this option is enabled. Should the analysis be canceled, this option is ignored, and the detector is left enabled.</p> |

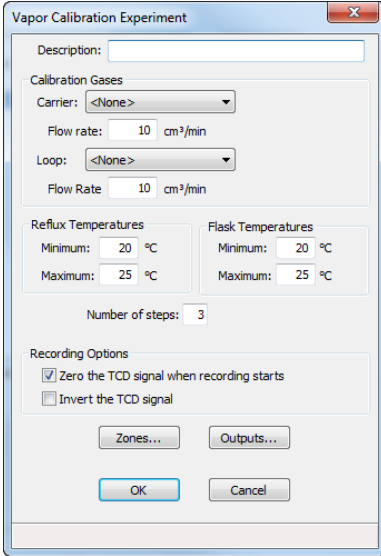

Experiment Fields (continued)

| Selections | Description |
|--------------------------|---|
| Vapor Calibration |  <p>A separate calibration of the TCD must be made when vapor is to be used during analysis. The <i>Vapor Calibration</i> experiment allows the calibration of the TCD so that peak area data can be converted to volume data. During a <i>Vapor Calibration</i>, one vapor at a series of temperatures is flowed through the analyzer and the resultant signal readings are recorded. The analyzer uses this data to calculate the unknown concentrations of vapors flowing past it during subsequent analyses.</p> |

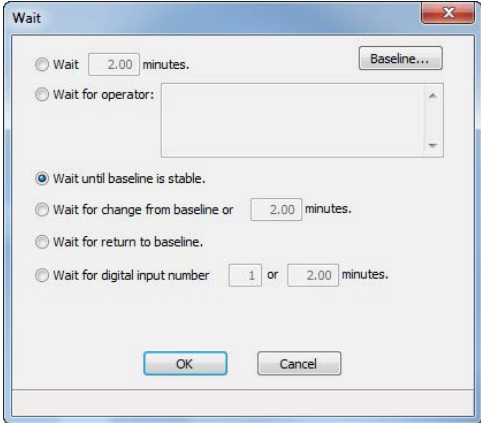
Experiment Fields (continued)

| Selections | Description |
|-------------|--|
| Wait |  <p>Specify a waiting routine.</p> <p>Wait [n] minutes. [button] Specify the time to wait.</p> <p>Wait for operator. [button] Enter a description of the operator task. During an analysis, the entered message displays at the appropriate time. The analysis continues after the operator clicks OK.</p> <p>Wait until baseline is stable. [button] Specify if the analysis should wait until the baseline becomes stable, then click Baseline to specify the settings.</p> <p>Wait for change from baseline or [n] minutes. [button] Specify the time to wait, click OK, then click Baseline to specify the settings.</p> <p>Wait for return to baseline. [button] Waits for a return to baseline. If enabled, click OK, then click Baseline to specify the settings.</p> <p>Wait for digital input number. [button] Enter the number of the digital input source being awaited, then specify the maximum number of minutes to wait for input. If the digital input is not received before the time elapses, the analysis will continue, and a warning message is displayed. See Auxiliary Inputs and Outputs on page C - 1.</p> |

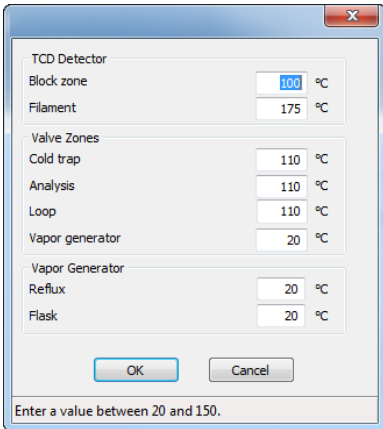
Experiment Fields (continued)

| Selections | Description |
|---|--|
| Zones | <p>Click to set the heat zone temperatures.</p>  <p>The <i>Filament</i> temperature must be set at least 20 °C higher than the <i>Block zone</i> temperature.</p> <p>The <i>Reflux</i> must be at least 10 °C cooler than the <i>Flask</i> zone.</p> <p>If the optional vapor generator is not installed when the analysis is started, the vapor generator fields are ignored by the application.</p> |
|  | <p>For fields and buttons not listed in this table, see Common Fields and Buttons on page 2 - 4.</p> |

REPORT OPTIONS

File > Open > [.RPO File]

Or, click the *Report Options* tab when in *Advanced* option presentation.

The *Calculations* document can be found on the Micromeritics web page (www.micromeritics.com).

Additional reports are available using the *Reports* menu.

Use to specify report options for data collected from an analysis or manually entered data. *Report Options* files also help in customizing report details such as axis scale, axis range, column headings, and components of thickness curve equations. These files may contain tabular reports, plots, or both, as well as advanced report tables.

Customized report options files can be created then loaded into a sample file, allowing quick generation of reports.

Report Options files may be defined to include overlay options. This system allows the overlay of up to 25 plots of different samples onto a plot of the same type or overlay one plot type onto a different plot type from the same analysis.

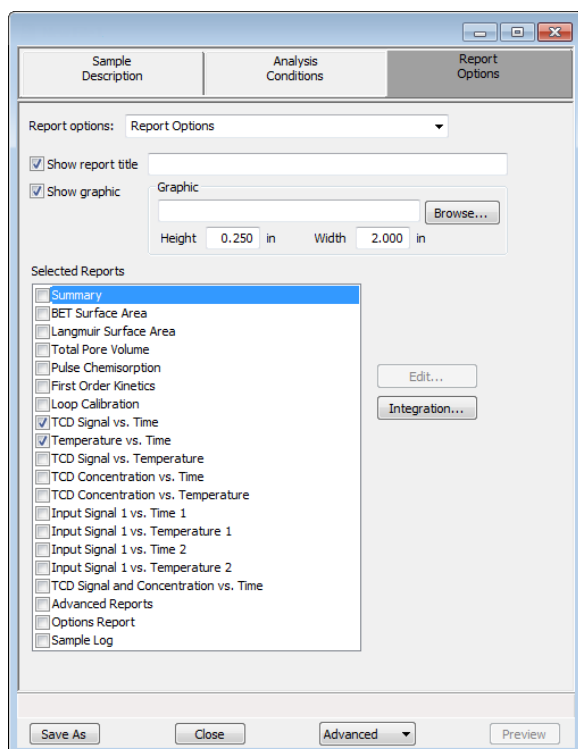

Report Options

| Selections | Description |
|--|--|
| Edit [<i>button</i>] | Select the report in the Selected Reports box. See Selected Reports on page 7 - 1 . |
| Integration [<i>button</i>] | See Peak Detection / Integration Options on page F - 1 |
| Report Options [<i>drop-down box</i>] | Browse for a .RPO file that contains report options parameters to be used in the report. |
| Selected Reports [<i>group box</i>] | Select the report names to include in the report. |
| Show graphic [<i>check box</i>] | Use to show a graphic on the report header. Height/Width. Enter the height and width of the selected graphic. These values determine the graphic's appearance on the generated report. |
| Show report title [<i>check box</i>] | Select then enter a report title to appear on the report header. |
|  <p>For fields and buttons not listed in this table, see Common Fields and Buttons on page 2 - 4.</p> | |

5 *PERFORM AN ANALYSIS*

ANALYSIS TEMPERATURE GUIDELINES FOR ALL ANALYSIS TYPES

- **Starting Temperature.** Experiments should be started at a temperature that is lower than that at which the reaction begins. If the reaction begins below ambient temperature, use the optional CryoCooler.
- **Maximum Temperature.** The experiment's maximum temperature is limited to the temperature at which the sample sinters.
- **Ramp Rate.** The recommended ramp rate is 5-10 °C/min, however a different ramp rate can be specified. For example, if using 500 °C as the starting temperature of the reaction, it is more expedient to ramp the temperature rapidly (for example, 50 °C/min.) to a value near 500 °C, then proceed with the experiment at 5-10 °C/min.

COOLING OPTIONS

The furnace must cool during temperature programmed analyses if:

- a low temperature is required as part of the analysis, or
- to speed cooling of the furnace to increase sample throughput or reduce analysis time.

If cooling is required for the analysis, a CryoCooler may be necessary. Cooling options are:

- **Allow the temperature to return to ambient over time.** If time is not a consideration, allow the furnace to cool over time. It may take two hours or more for the furnace to cool from 1100 °C to near ambient. This may be acceptable when time is not limited.
- **Promote cooling by manually opening the furnace.** The furnace cools more rapidly when it is open. This option requires the availability of an operator to open and close the furnace at the appropriate times during analysis.



When it has been used recently, the furnace and/or the sample tube may be hot. Use the cotton gloves provided in the accessory kit when handling heated surfaces. These cotton gloves are not intended to protect hands when heated surfaces are above 60 °C.

- **Connect a cooling gas or cryogen flow to the inlet on the front of the furnace.** A cooling flow of an appropriate gas or cryogen can be connected to the inlet on the furnace. Read the warning listed above. This option can provide rapid cooling of the sample but offers no control of the target temperature or the speed at which it is achieved. The gas or cryogen must be non-reactive — such as nitrogen, air, helium, argon, liquid nitrogen, or liquid argon.
- **Connect the optional CryoCooler to the inlet in the front of the furnace.** The CryoCooler provides control of the sample temperature to temperatures as low as -100 °C. The CryoCooler is required for accurate analyses that include signal recording below ambient. The CryoCooler Operator Manual can be found on the Micromeritics web page (www.micromeritics.com).

DEWAR PRECAUTIONS



Always handle glass Dewars with care. Any product incorporating a vacuum is a potential safety hazard and should be treated with caution. If in doubt, contact your safety officer.



Improper handling, disposing of, or transporting potentially hazardous materials can cause serious bodily harm or damage to the instrument. Always refer to the SDS when handling hazardous materials. Safe operation and handling of the instrument, supplies, and accessories are the responsibility of the operator.



Do not pour liquid nitrogen directly into a sink. Doing so may cause drain pipes to burst.

When handling Dewars containing liquefied gases or cryogenic liquids:

- Wear protective equipment:
 - goggles or face shield
 - an insulated or rubber apron
 - insulated gloves
- When pouring liquefied gases from one container to another:
 - cool the receiving container gradually to minimize thermal shock
 - pour the liquified gas slowly to prevent splashing
 - vent the receiving container to the atmosphere

FOR GLASS DEWARS

- Use a plastic stirring rod when stirring substances in a Dewar containing liquefied gases (or other materials of extremely low temperature). Do not use a glass or metal stirring rod unless it has a protective coating.
- Do not handle heavy objects above the Dewar. If unavoidable, place a protective cover over the Dewar opening. If an object of sufficient weight is accidentally dropped into the Dewar, shattering may occur.
- If the Dewar has a protective mesh covering, do not remove it. This cover minimizes the risk of flying particles should the Dewar be knocked over, dropped, or broken.

MIXING AN IPA/LN₂ SLURRY



An isopropyl alcohol (IPA) /liquid nitrogen (LN₂) slurry is used to maintain cold trap temperatures of approximately -80 °C. Improperly mixing an IPA/LN₂ slurry could cause injury. If the mixture is not stirred continuously, gas may build up under the surface, causing the liquids to splash out of the Dewar.

1. Chill a 600 mL Dewar by rinsing it with LN₂. Allow a small amount of LN₂ to remain in the bottom of the Dewar (approximately 1 cm deep).
2. Stirring constantly, slowly add approximately 500 mL of IPA. For greatest safety, use a laboratory squirt bottle. Squirt the stream of IPA along the inside edge of the Dewar, close to the top of the Dewar, allowing the IPA to flow down the inside wall of the Dewar. Do not stop stirring the mixture in the bottom of the Dewar, even if stirring becomes difficult. As stirring and adding IPA continues, the mixture will loosen and become easier to stir.
3. When all the IPA has been placed in the Dewar, slowly begin pouring LN₂ into the Dewar. Approximately 1 liter is needed. Continue to stir the mixture as LN₂ is added. As ice chunks form, break them up and stir them down into the mixture. Avoid splashing. Gently knock ice chunks away from the sides of the Dewar and continue stirring. Add liquid nitrogen until the slurry is within 25 mm (1 in.) of the top of the Dewar.
4. Lift the stirrer out of the slurry and observe as the slurry drips into the Dewar; the stirrer should be thickly coated with slurry.

The goal is to achieve a slurry that has a thick, syrupy consistency without large chunks. When the slurry is cold enough, small pieces of ice may be present (10 - 20% of the mixture). A little ice accumulation along the sides of the Dewar is acceptable.

PROTECT DETECTOR FILAMENTS BY FLOWING GAS



A carrier gas must be flowing through the detector whenever the detector filaments are turned on; otherwise, the filaments will deteriorate and lose sensitivity. If the gases are shut off, the filaments are automatically turned off after five minutes.

The flowing gas also continuously cleans the plumbing of any water vapor which can enter when the sample tube is removed. Ten cm³/min is sufficient to perform this function.

PREPARE FOR ANALYSIS

It is recommended to perform the tasks in the provided order.

CLEAN AND LABEL SAMPLE TUBES



The equipment images in this topic may differ slightly from your equipment; however, the instructions are the same unless otherwise noted.

Sample tubes and filler rods must be clean and dry before samples are added and weighed. The following table indicates which materials are needed for cleaning. The procedures following the materials list are recommended.

| Supplied by Micromeritics | Supplied by User |
|---|--|
| <ul style="list-style-type: none"> ■ Funnel ■ Sample data worksheet ■ Sample tube ■ Sample tube brush ■ Sample tube rack ■ Sample weighing support ■ Stopper for sample tube | <ul style="list-style-type: none"> ■ Acetone or isopropyl alcohol ■ Analytical balance ■ Detergent (such as Alconox) ■ Drying oven ■ Forceps ■ Insulated gloves ■ Pipe cleaners ■ Rubber gloves or clean, lint-free cloth ■ Safety glasses ■ Ultrasonic cleaning unit ■ Waste container |

1. Preheat drying oven to 110 °C.
2. Verify that the ultrasonic cleaning unit is clean.
3. Use 5 grams of Alconox (or other suitable detergent) per 500 mL of warm water and fill the ultrasonic unit with enough water to cover the sample tubes and filler rods (if used). If too much detergent is used, it may be difficult to rinse from the sample tubes. Ensure the detergent is dissolved before placing the sample tubes and filler rods into the water.
4. Fill the sample tubes with warm water and place them in the ultrasonic cleaning unit, then place the filler rods in the unit. Turn on the ultrasonic cleaning unit for approximately 15 minutes.



5. Use rubber gloves to ensure no oils or residue are transferred to the clean tubes and filler rods, then remove the sample tubes and filler rods from the unit.
6. Clean the interior of the sample tubes with the brush supplied with the analyzer.
7. Rinse the sample tubes and filler rods thoroughly with hot water. Rinse again with isopropyl alcohol or acetone. If isopropyl alcohol or acetone is not available, deionized water may be used.



8. Stand the sample tubes on the sample tube rack and place the filler rods in a basket or in the rack. Bake in a vacuum oven for two hours at 110 °C.



Samples tubes can also be cleaned with high-purity acetone or isopropyl alcohol and dried for about 10 minutes under heat. If using this method, continue with step 10.

9. Remove the sample tubes and filler rods from the oven and allow to cool.



Do not insert the filler rods at this time. Filler rods are inserted before the sample tube is installed on the analysis port.

10. Blow out the sample tubes with oil-free compressed air.
11. Rinse the sample tube closure with isopropyl alcohol, then wipe the sample tube closure dry with a clean, lint-free cloth.
12. Label the sample tube and stopper for identification.
13. Replace the rubber stopper.

PREPARE THE SAMPLE

To obtain the most repeatable, accurate results:

- Use approximately the same amount of sample for each analysis (especially if data are compared sample to sample).
- Ensure the sample is well dispersed in the tube, not against the side or walls of the tube.
- Ensure the sample particle size distribution remains fairly constant from sample to sample. (Large particles of a substance reduce at a different rate than small particles of the same substance.) For samples with a wide particle size distribution, care should be taken that each sample is representative of the entire lot's distribution.

Micromeritics recommends analyzing samples weighing between 20 mg and 2 g. When determining a sample amount, consider that the sample must be contained within the bottom 20 mm (3/4 in.) of the sample tube.

When determining sample size, consider the percentage of active metals in the sample. Materials with lower percentages of active metals may require larger sample amounts for analysis, while materials with high percentages of active metals can be analyzed using smaller samples.



Larger amounts of very fine powders may become packed in the sample tube and block gas flow. The resulting increase in gas pressure may force some of the sample out of the sample tube, causing contamination of, or damage to the analyzer. A possible solution is to expand the sample bed with quartz wool.

CREATE THE SAMPLE FILE

[Sample Files on page 3 - 2](#)

DETERMINE THE SAMPLE MASS FOR CHEMISORPTION

[Use Quartz Filter Discs for Chemisorption on the facing page](#)
[Sample Data Worksheet for Chemisorption on page H - 6](#)



Bulb sample tubes are for pellets and other samples without loose particles. Using powder samples in bulb tubes may cause the loose particles to go into the analyzer's exhaust.



The equipment images in this topic may differ slightly from your equipment; however, the instructions are the same unless otherwise noted.

1. Record the sample tube identification on the *Sample Data Worksheet*.
2. Place the sample weighing support on the balance. Tare the balance and allow it to stabilize at zero.
3. If analyzing a powder or sample made of fine particles, push a piece of quartz wool all the way down into the sample tube.
4. If using *quartz wool*, put a second piece of quartz wool just inside the sample tube. If using *filter discs*, push a filter disc down into the tube until it sits on top of the quartz wool. Place a second filter disc just inside the sample tube.
5. Place the sample tube set (sample tube with quartz wool or filter discs and stoppers) on the sample support. Record the stabilized mass on the *Sample Data Worksheet*.

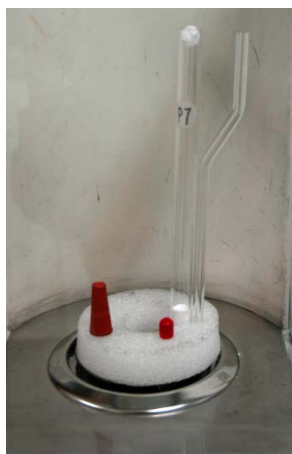

6. Remove the sample weighing support and sample tube set from the balance.
7. Place the sample container on the balance and allow the balance to stabilize at zero.



Do not touch the sample with bare hands. Oil from hands could affect the accuracy of results.

8. Slowly add approximately 0.5 to 1.0 gram of sample to the sample container.
9. If a second piece of quartz wool or filter disc was inserted, remove the top portion of the quartz wool or the filter disc from the sample tube.
10. Use a funnel to slowly pour sample from the container into the sample tube on top of the quartz wool in the tube.



Ensure all sample in the container is placed in the sample tube to avoid errors caused by incorrect sample mass.

11. If using *quartz wool*, insert the top portion of quartz wool into the tube and press it down. If using *filter discs*, insert the filter disc into the tube and press it down.



Ensure the disc is flat on top of the sample. A seal must be created around the edge to prevent the sample from escaping.

12. Wipe the top of the sample tube with a clean, lint-free cloth, such as a Kimwipe[®], to remove any quartz wool that may have adhered to the surface.
13. Weigh the sample tube set containing the sample and the stoppers. Record this mass as the *Sample + tube*.

Use Quartz Filter Discs for Chemisorption



The equipment images in this topic may differ slightly from your equipment; however, the instructions are the same unless otherwise noted.



The use of quartz wool is not mandatory; however, it can provide extra protection for light powdered samples.



Wear latex gloves when handling the quartz sample tube. The natural oils in human skin can chemically damage and weaken the quartz tube. It is also important that the sample tube and its components, as well as the sample and exhaust ports, be clean and free of debris. Dust particles from quartz wool or the insulator disc of previous analyses may adhere to the port and/or components, preventing a proper seal of the sample tube.

Use quartz filter discs or quartz wool to aid in chemisorption sample preparation. Quartz filter discs (placed both below and above powdered samples) not only provide a more uniform sample surface but also keep the analyzer free of sample debris. The filters can be used up to 900 °C.

1. Insert a small portion of quartz wool into the sample tube to serve as a support for the powdered sample. Use a filler rod or smaller sample tube to push the quartz wool to the bottom of the sample tube.

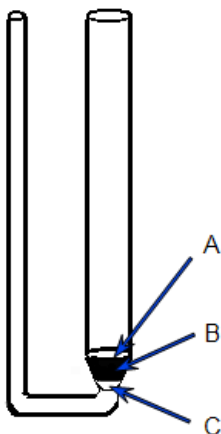

- A. Quartz disc
- B. Sample
- C. Quartz disc and quartz wool

2. Insert a quartz disc into the sample tube and push it into the tube until it rests on top of the quartz wool. Inspect the disc to ensure that there is a good seal and that the sample will not go past the filter. An additional filter can be inserted if needed.
3. Insert a second filter disc on top of the quartz wool. Ensure that the filter is placed high enough into the sample tube for easy retrieval.
4. Take the initial tube weight (with both filters).
5. Remove the top filter disc. Place it on a clean surface, then use a funnel to add the powdered sample on the bottom filter disc.
6. Reinsert the top filter disc into the sample tube, then use a rod or smaller sample tube to push it down until it reaches the top of the sample.
7. To remove the quartz wool and disc after analysis, use the quartz wool extractor tool.

SAMPLE TUBE INSTALLATION

[Sample Tube on page 9 - 24](#)

FILL AND INSTALL THE DEWAR

[*Dewar Precautions on page 5 - 3*](#)

[*Check and Clean the Dewar on page 10 - 15*](#)

To surround the cold trap, the Dewar must rest on a small stand. Hold the Dewar beneath the cold trap, then raise it enough to slide the stand underneath the Dewar. Lower the Dewar until it rests on the stand. Ensure the cold trap is immersed.

If performing an analysis that requires use of the cold trap and cryogen, check the cryogen level in the Dewar. It should be approximately 25 mm (1 in.) from the top.



The cryogen must not be cold enough to trap the carrier gas or analysis gas. Do not use liquid nitrogen with argon carrier gas. For example, use an alcohol and liquid nitrogen slurry (-80 °C).

PERFORM A SAMPLE ANALYSIS

Unit [n] > Sample Analysis

[Analysis Tutorials on page 11 - 1](#)

1. From the menu bar, select **Unit [n] > Sample Analysis**.
2. Click **New** to create a new sample file, or click **Browse** to select an existing file.

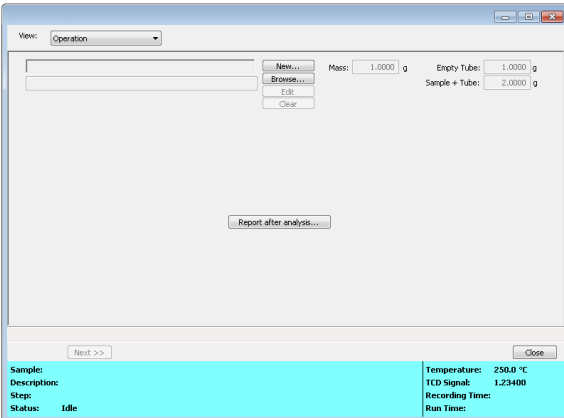

3. Edit the *Mass*, *Empty Tube*, and *Sample +* fields, as needed.
4. Click **Next** and select a calibration file for each experiment.

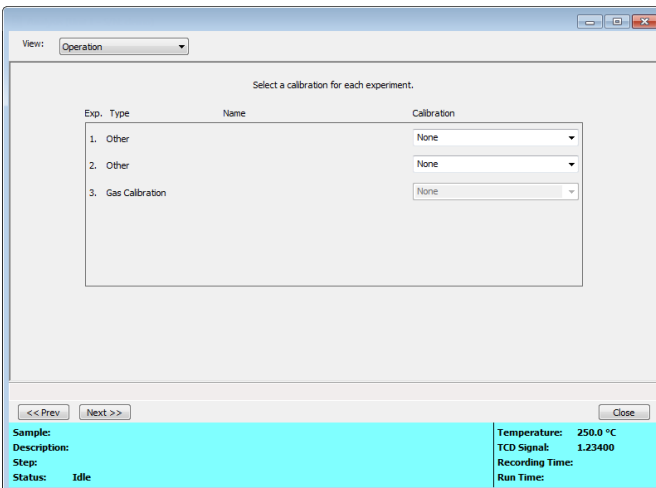

5. Click **Next** and read the warnings.

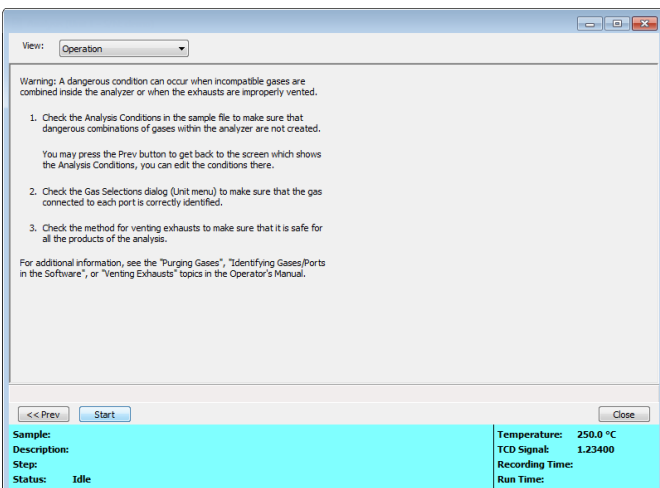

6. Click **Start** to begin the analysis.

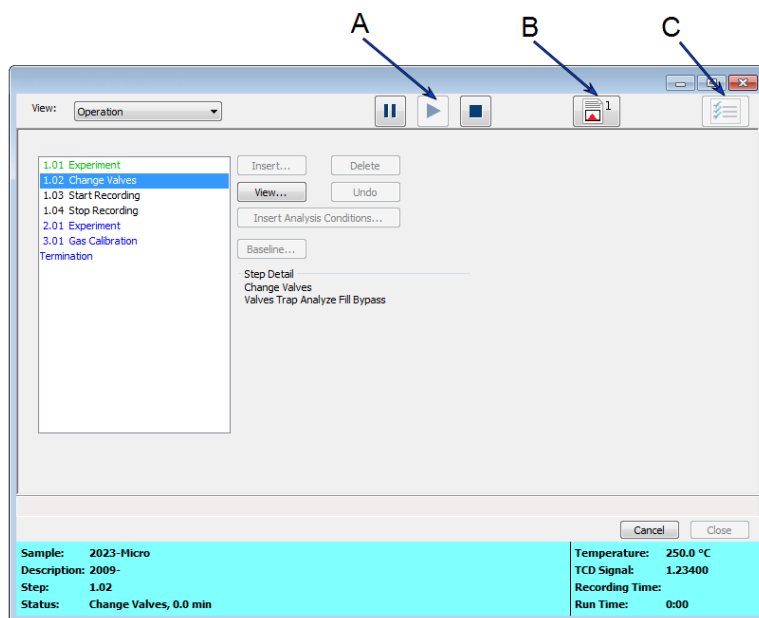

- A. Suspend/Resume/Skip buttons
- B. Port report buttons
- C. Live graph settings

The *Operation* view displays experiment steps and details as steps are performed. Text colors indicate the progress. Completed steps are shown in green. In progress steps are shown in light blue. Pending steps are shown in black, dark blue or dark green (depending on their nesting level).

7. To change steps that have not been started:

- Click **Suspend**, select the step, then click the appropriate button for modification.
- Click **Resume** to continue the analysis.

8. Select the *Results* view to see the analysis in progress.

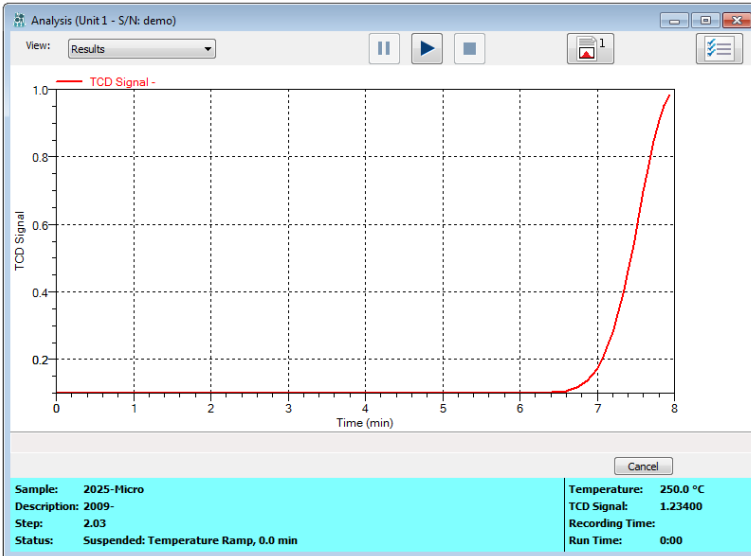

9. Click the **Live Graph Settings** button to hide or show different settings.

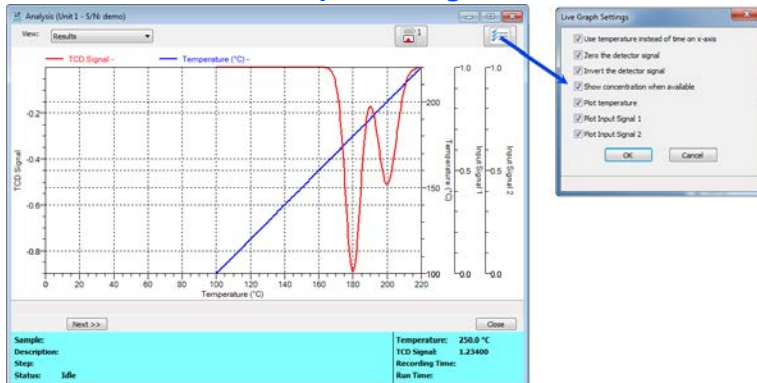

RESET THE ANALYSIS

Unit [n] > Reset

Use to abort the current analysis and return the analyzer to a safe state. The following actions occur:

- All gas flows stop
- The detector is disabled
- The heat zones are reset to 0 °C
- The target furnace temperature is reset to 20 °C

Do not select this option unless you are sure you want to stop the current analysis. The analysis cannot be resumed after *Reset* is selected.

6 ABOUT REPORTS

Reports can be generated for data collected on a sample that has completed analysis, collected on a sample currently being analyzed, or manually entered.

Reports > Start

Generates a report on a sample analysis.

Reports > Close Reports

Closes all open reports. This option is unavailable if reports are being generated.

Reports > Open Reports

Opens the selected report.

INTERACTIVE REPORTS

When opening a sample file that contains data from a complete or in-progress analysis, the interactive reporting feature is enabled.

1. When opening a sample file that contains analysis data, a plot of the data collected during analysis will display.
2. From the view selector drop-down list at the bottom of the window, do either of the following:
 - Change the option presentation of the sample description window to either *Basic* or *Advanced* to modify certain file parameters.
 - Select another plot from the list and edit the data contained in the plot.
3. When ranges are edited, the changes are reflected immediately in the plots and the summary data displayed in the window. Some editing options are:
 - Drag the blue bars to increase or decrease the range of data included in the plot.
 - Right-click to display a popup menu to include reports; enable or select overlays; edit curves, axes, legends, titles; and copy and paste the data in a graph or in tabular format.
4. Click **Save**.

MICROACTIVE REPORTS

This feature provides a quick and easy way to investigate and manipulate analysis data using a variety of reporting methods.

When a sample file with a status of *Complete* or *Analyzing* is opened, a linear plot and log plot of the data collected during analysis are displayed as well as a summary of the analysis giving the total pore volume. Numerous reports are accessible from a drop-down menu.

When a report is opened, plots and summary data are displayed, and in some reports certain parameters are also displayed. Plots may be edited by selecting the data points or data point range to be included in the plots and modifying the parameters. When a report is edited, the results are immediately reflected in the plots and summary data.

PEAK EDITOR



Analysis condition defaults for metal stoichiometry factors can be set using the sample information metal table editor. Stoichiometry factors can also be set for each pulse chemisorption experiment using the analysis conditions experiment step editor. If required, stoichiometry factors for a completed pulse chemisorption experiment can be viewed and modified using the peak editor's stoichiometry settings window.

The *Peak Editor* feature provides the viewing and editing of up to 16 dynamic analysis experiments. The *Peak Editor* options are accessed by opening a Completed sample file and selecting a "Peak Editor" entry from the drop-down menu at the bottom of the report window. Peaks can be defined, edited, or deleted.

Peaks are defined by a baseline. If the **Find All Peaks** button is clicked (enabled when *Edit Peaks* is selected), the *Peak Editor* will define baselines for all positive peaks detected according to the *Integration* window accessed from the **Integration** button. For Loop calibrations, peaks are found using events that occurred during the analysis — such as the time an injection started — instead of peak detection options. The baseline can be manually defined by double left clicking in the signal graph on the starting baseline point (this places the Peak Editor into baseline creation mode). The ending baseline point is then defined by left clicking in the signal graph on the ending baseline point. Baseline creation mode can be exited by right clicking in the signal graph.

PEAK EDITOR VIEW

[Open a Sample File on page 3 - 4](#)

When a sample file with a *Complete* status is opened, three views are available:

- Overlay Experiments View
- Stacked Experiments View
- Peak Editor

To change the view, select the view from the drop-down list at the bottom of the graph window. Only the *Peak Editor* view allows editing of the experiment.

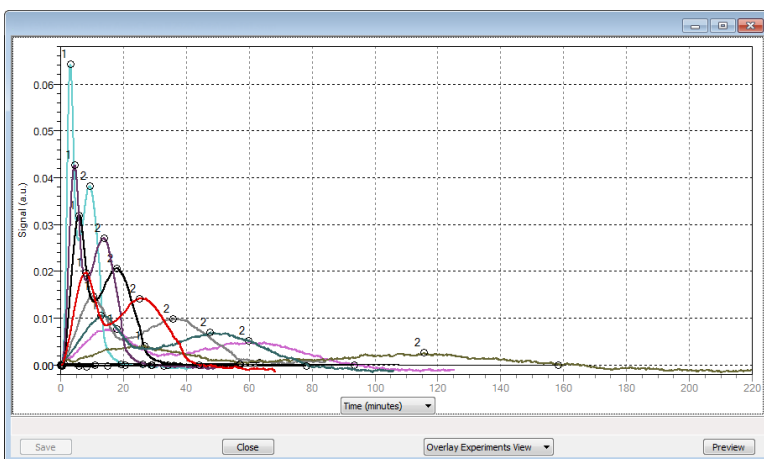

**Example of
Overlay Experiments view**

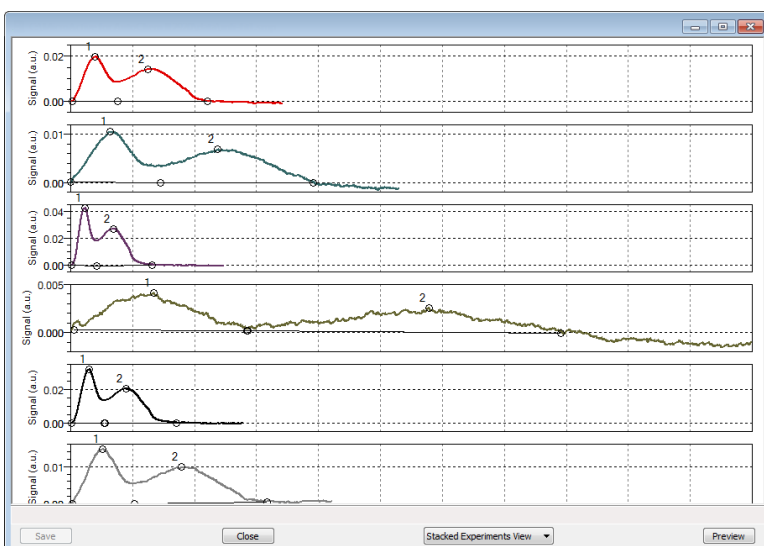

**Example of
Stacked Experiments view**

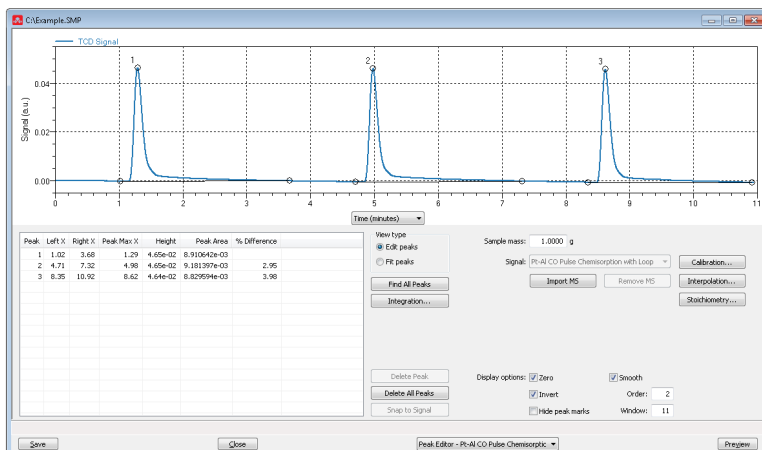

Example of Peak Editor view

Peak Editor

| Selections | Description |
|--|---|
| <p>Calibration [button]</p> | <p>Calibration. Select a previously defined calibration file. If the experiment and calibration gases differ, a warning displays. The system also compares the experiment flow rate and calibration flow rate. If they differ, a warning displays.</p> <p>Experiment Information</p> <ul style="list-style-type: none"> ■ Description. Enter a description of the current experiment. ■ Type of analysis. Select the analysis type that most closely describes the current experiment. This will affect what is reported as part of the Summary report data and the available reports. ■ Vapor. Select a vapor before creating or applying a vapor calibration. This field is only visible for vapor experiments. ■ Loop volume. Displays the volume of the gas injection loop. |

Peak Editor (continued)

| Selections | Description |
|------------------------------------|---|
| | <ul style="list-style-type: none"> ▪ Ambient temperature. Displays the ambient temperature entry from the <i>Options > Environmental Defaults</i> setting. This field may be edited. ▪ Atmospheric pressure. Displays the atmospheric pressure entry from the <i>Options > Environmental Defaults</i> setting. This field may be edited. ▪ Active concentration. Displays the percent of the gas mixture which is composed of the reactive gas versus an inert filler. This value is used for data reduction, including pulse chemisorption. ▪ P₀ of adsorbate. Displays the saturation pressure of the adsorbate. ▪ Adsorbate cross-sectional area. Displays the area that a single adsorbed molecule occupies on the surface of the sample. It is used in surface area calculations. ▪ Manual Injections. Displays the injection settings entered during analysis. This table may be edited. <p>Create Calibration. Create a signal calibration from the currently selected experiment.</p> |
| Delete [button] | <p>Clears all peaks from the table and removes all markings from the peaks.</p> <p>To delete a single peak, select the peak from the peak table or left click the peak to enable the Delete Peak button.</p> <ul style="list-style-type: none"> ▪ Delete All is available only when the <i>Fit Peaks</i> selection is enabled. ▪ Delete All Peaks is available only when the <i>Edit Peaks</i> selection is enabled. ▪ Delete Peak is available only when the <i>Fit Peaks</i> selection is enabled. |
| Delete Baseline [button] | <p>Removes the baseline from the graph.</p> <p>Available only when the <i>Fit Peaks</i> selection is enabled.</p> |
| Display Options [group box] | <p>Use to change how the data are displayed.</p> <p>Zero. Select to zero the signal (starting baseline).</p> <p>Invert. Select to invert the signal (peak).</p> <p>Hide Peak Marks. Select to hide all marks from peaks.</p> <p>Smooth. Select to smooth the signal on the display.</p> <ul style="list-style-type: none"> ▪ Order and Window. Enabled when the <i>Smooth</i> checkbox is selec- |

Peak Editor (continued)

| Selections | Description |
|--|--|
| | <p>ted. The smoothing process uses the Savitzky-Golay filter to fit a polynomial order n into size of the specified window $[m]$.</p> |
| Find All Peaks [button] | <p>Defines baselines for all positive peaks detected according to the <i>Integration</i> window, accessed via the Integration button. Loop calibrations do not use Integration button settings when finding peaks.</p> <p>Find All Peaks automatically detects the peaks and draws the baseline for detection. Place the cursor over one of the baseline end points and double left click to grab the baseline. Move the cursor to the new position and right click. Available only when the <i>Edit Peak</i> selection is enabled.</p> |
| Gaussian [drop-down box] | <p>Standard Gaussian curve. Available only when the <i>Fit Peaks</i> selection is enabled.</p> |
| Import M.S. [button] Remove M.S. [button] | <p>Mass spectrometer data can be imported and overlaid in the <i>Overlay Experiment</i> view. In the <i>Peak Editor</i> view, it is saved as a separate signal.</p> <p>Import M.S. Click to import mass spectrometer data. In the bottom right-hand corner of the pop-up window, select the type of mass spectrometer file to import (Quadera, Quadstar, MKS, or TAMS). Select the file, then click Open to import the signals.</p> <p>A popup window prompts the user to sync the temperature data with the current experiment temperature data.</p> <p>Remove M.S. Click to remove all previously imported mass spectrometer signals from the current experiment.</p> |
| Import standard peaks [button] | <p>Imports the saved peak parameters from the <i>Edit Peaks</i> view. Available only when the <i>Fit Peaks</i> selection is enabled.</p> |

Peak Editor (continued)

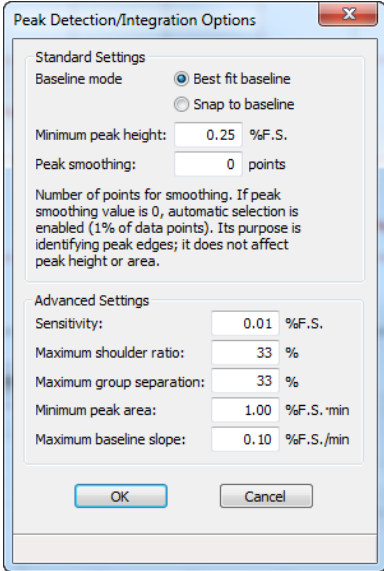
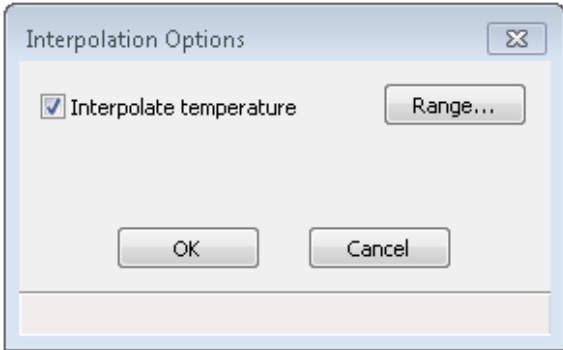
| Selections | Description |
|--|---|
| Integration Options [button] |  <p>See Peak Detection / Integration Options on page F - 1.</p> |
| Interpolation [button] | Interpolate Temperature. Select to interpolate the temperature. Click Range to specify a temperature range. Slide the blue bars on the graph to indicate the range.  |
| Log Normal Skewed [button] | A 4-parameter, log-normal shape that allows for skewed peaks. This is the default peak. Available only when the <i>Fit Peaks</i> selection is enabled. |
| Peak fit model [button] | Select the peak shape. Available only when the <i>Fit Peaks</i> selection is enabled. Options include: Gaussian, Lorentzian, Pearson type VII, Pseudo-Voight, and Log Normal Skewed (3 and 4). |
| Sample mass [text box] | Calculates the mass-specific quantities. Initial value is taken from the sample information at the start of the analysis. |

Peak Editor (continued)

| Selections | Description |
|--|---|
| Snap to Signal [button] | Places the selected baseline point on the signal curve. |
| Stoichiometry [button] | See Active Metals for Chemisorption Analyzers on page 3 - 5 . |
| View Type [group box] | Edit Peak. Locates peaks via signal integration over a baseline. Fit Peaks. Locates peaks via function fitting to minimize residual over a baseline. |
|  <p>For fields and buttons not listed in this table, see Common Fields and Buttons on page 2 - 4.</p> | |

REPORT FEATURES AND SHORTCUTS

[Graph Features and Shortcuts on page 6 - 14](#)

Reports can be customized and manipulated using the toolbar, shortcut menus, the zoom feature, or axis cross-hairs.

- After analysis, reports can be viewed, printed, and/or copied and pasted into other documents.
- The report zoom feature provides the viewing of fine graph details and the ability to shift the axes.
- All reports contain a header displaying file statistics.

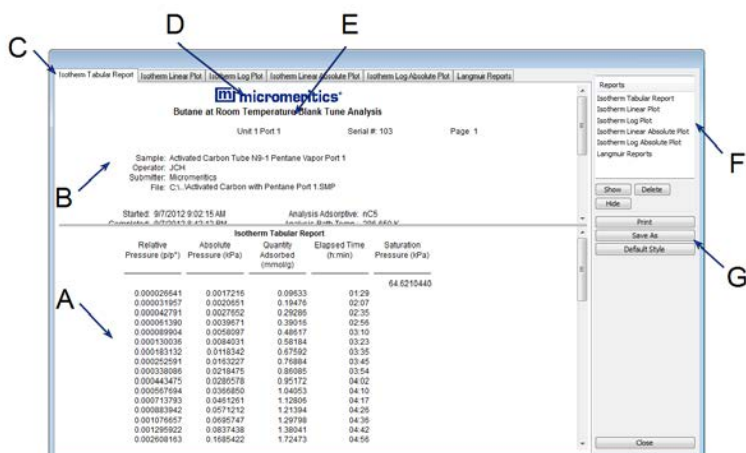

- A. Data display (graph or text)
- B. Header
- C. Generated tabs
- D. Graphic
- E. Title
- F. List box
- G. Toolbar

If configured, the report header can also contain a graphic and/or a title.

- Tabular and graphical reports contain sample and analyzer statistics such as analysis date/-time, analysis conditions, etc.
- The headers contain notes of sample file changes occurring after analysis.

REPORT HEADER SHORTCUTS

Right-click in the report header to display header shortcuts.

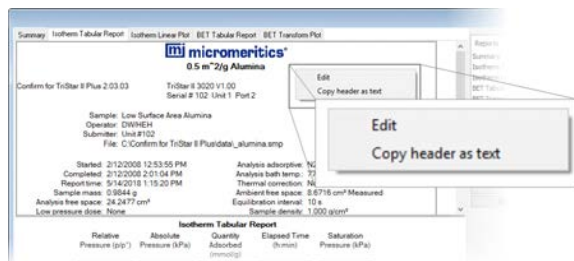

Report Header Shortcuts

| Selections | Description |
|---------------------|--|
| Copy header as text | Copies the report header as text. Text is copied to the clipboard and then can be pasted into other documents. |
| Edit | Opens a dialog box for editing the report title. |

REPORT TOOLBAR

The *Report* window has a toolbar on the right portion of the window and selectable tabs at the top of the report header. To view a specific report, either select the tab or the report in the *Reports* list box, then click **Show**.

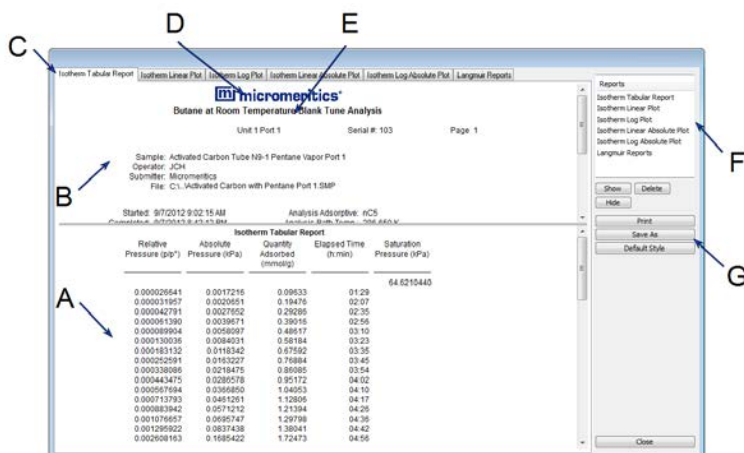

- A. Data display (graph or text)
- B. Header
- C. Generated tabs
- D. Graphic
- E. Title
- F. List box
- G. Toolbar

Report Toolbar

| Selections | Description |
|-------------------------------|--|
| Default Style [button] | Specifies default report parameters for fonts and curve properties. |
| Delete [button] | Deletes the selected report in the <i>Reports</i> list box. Deleted reports will have to be regenerated if deleted in error. |
| Hide [button] | Hides (or temporarily removes) the selected report from the tabbed view. The report name remains in the <i>Reports</i> list box. |
| Print [button] | Displays the <i>Print</i> window for report output. |
| Reports [group box] | Contains a list of all generated reports. The same reports display as tabs at the top of the report header unless the report has been hidden using the Hide button. |
| Show [button] | Displays the selected or hidden report in the <i>Reports</i> list box. |

For fields and buttons not listed in this table, see [Common Fields and Buttons on page 2 - 4](#).

TABULAR REPORT FEATURES AND SHORTCUTS

Display tabular report shortcuts by right-clicking in the body of the tabular report. Column shortcuts require right-clicking on the column to be modified.

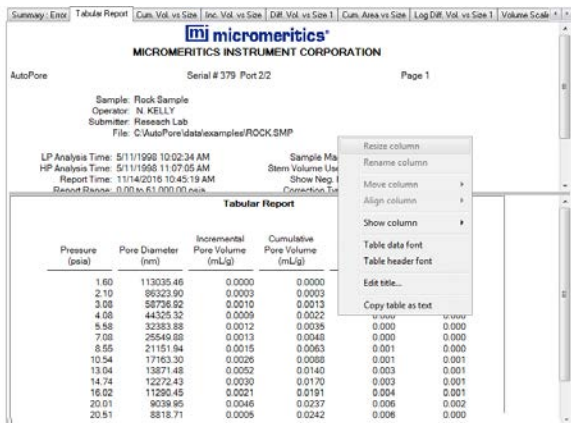

Tabular Report Shortcuts

| Selections | Description |
|--------------------|---|
| Align column | Changes the column alignment to either left, right, or centered. |
| Copy table as text | Copies the report contents to the clipboard as tab-delimited text. It can then be pasted into another document. |
| Edit title | Edits the report title and/or title font attributes. Click Font to modify font attributes. |
| Move column | Right-click the column to be moved. Select <i>Move column</i> on the shortcut menu and select <i>Left</i> or <i>Right</i> for the move. |
| Rename column | Right-click the column to be renamed. Select <i>Rename column</i> on the shortcut menu and enter the new column name. |
| Resize column | Right-click the column to be resized. Select <i>Resize column</i> on the shortcut menu and enter the new column width in inches. |
| Show column | Displays a list of all columns. Click a column to add a checkmark to show the column or remove the checkmark to hide the column. |
| Table data font | Right-click in the report data. Select <i>Table data font</i> on the shortcut menu. |
| Table header font | Right-click in the report data. Select <i>Table header font</i> on the shortcut menu. |



For fields and buttons not listed in this table, see [Common Fields and Buttons on page 2 - 4](#).

GRAPH FEATURES AND SHORTCUTS

Right-click in the graph area to display graph report shortcuts.



Graph Shortcut Options

| Selections | Description |
|--|--|
| Autoscale all axes | Returns the report to full view after using the zoom feature. |
| Copy graph | Copies the graph to the clipboard. It can then be pasted into other software programs. |
| Delete baseline  | Deletes the baseline from the graph |
| Edit axis | <p>Edits the selected axis properties.</p> <div data-bbox="553 716 1052 1142" data-label="Image"> </div> <p>Gridlines. Changes how to display major / minor grid lines.</p> <p>Scale.</p> <ul style="list-style-type: none"> ▪ Autoscale minimum/maximum. To manually specify minimum / maximum autoscale, deselect the option and enter the new amount in the text box. ▪ Invert scale. Inverts the scale. ▪ Linear/Logarithmic. Scales the graph as linear or logarithmic. ▪ Scale font. Modifies the font for the scale label. Deselect <i>Use default font</i> to enable font options. <p>Title. Edits the selected axis label.</p> <p>Title font. Modifies the font for the selected axis label. Deselect <i>Use default font</i>. Select new font attributes for report data. Enable <i>Use default font</i> to reset default fonts.</p> |

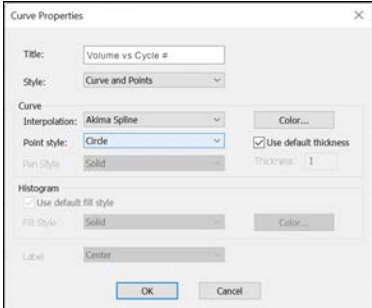
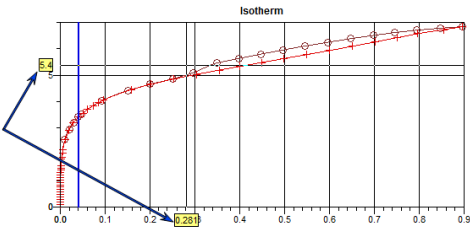
Graph Shortcut Options (continued)

| Selections | Description |
|-------------------|---|
| Edit curve | <p>Edits selected curve properties.</p>  <p>Color. Changes the curve color.</p> <p>Curve. Changes the interpolation, point style, and pen style for the selected curve. These options are disabled if <i>Use default fill style</i> is selected in the <i>Histogram</i> group box.</p> <p>Histogram. Enabled only if <i>Histogram</i> is selected in the <i>Style</i> drop-down list. Specifies the type of fill, fill color, and label position for the selected curve.</p> <p>Label. Designates where the graph point labels will display (left, right, center, etc.) on the SPC report.</p>  <p>Style. Selects another style for the collected data curve.</p> <p>Title. Changes the title of the selected curve.</p> <p>Use default thickness. Uses the default curve thickness. Deselect to enter a new thickness number in the <i>Thickness</i> text box.</p> |

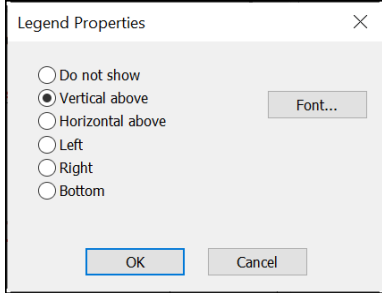
Graph Shortcut Options (continued)

| Selections | Description |
|--|--|
| Edit legend | Changes the legend location and font.  |
| Edit title | Changes the report title. |
| Reset axis limits to initial setting | Removes the cross-hair and returns the graph back to the initial setting. |
| Show curve | Displays a list of all curves. Select the curve(s) to display. |
|  <p>For fields and buttons not listed in this table, see Common Fields and Buttons on page 2 - 4.</p> | |

AXIS CROSS-HAIR

Left-click on the graph to view the cross-hair coordinates.

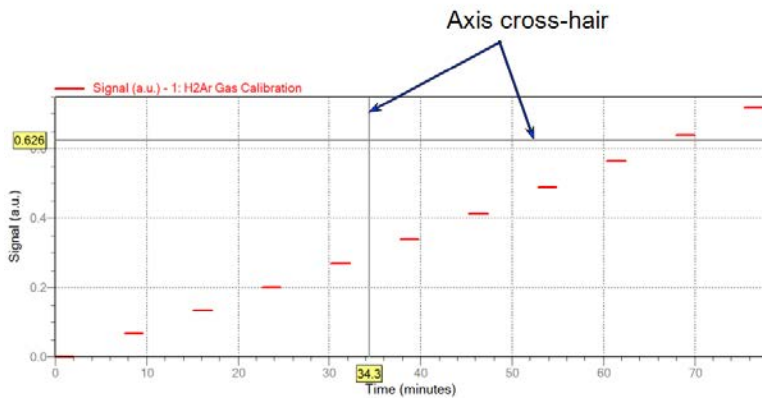

Example of Axis cross-hair feature

ZOOM FEATURE

Use the zoom feature to examine graph details. Click, hold, and drag the left mouse button on the graphical area to be enlarged. A box will display in the area to be enlarged. To return to normal view, right-click in the graph and select *Autoscale all axes*.

GRAPH GRID LINES

Options > Graph Grid Lines

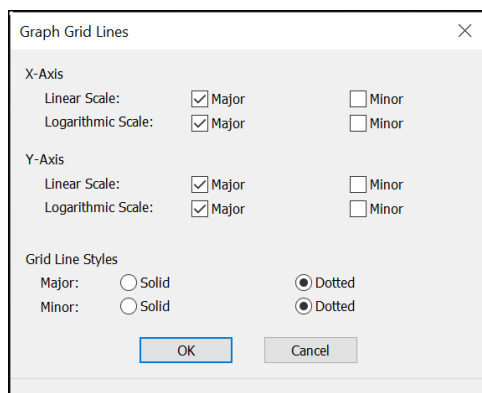

Use to select how grid lines appear on reports. This menu option is not available if using *Restricted* option presentation.

Graph Grid Lines

| Selections | Description |
|--|---|
| Grid Line Styles [selection] | Select if the major and/or minor grid lines should appear as solid or dotted lines. |
| X-Axis / Y-Axis [selection] | Select major and/or minor lines to display in reports for the logarithmic and linear scales. Deselect this option to remove the grid lines. |
|  For fields and buttons not listed in this table, see Common Fields and Buttons on page 2 - 4 . | |

REPORT EXAMPLES FOR AUTOChem ANALYZERS

FIRST ORDER KINETICS REPORT



Micromeritics Instrument Corporation – AutoChem II 2920

MicroActive for AutoChem II 2920 Version 6.00 Serial # 161 Unit 1 Page 8 of 35

Sample: Heat of desorption - fit peaks - strong chemi
 Operator:
 Submitter:
 File: C:\MicroActive for AutoChem II 2920\data\mf-fit2.smp

Started: 4/4/2006 2:05:12 PM Sample mass: 0.0591 g
 Completed: 4/5/2006 11:13:41 PM Report time: 10/19/2017 11:38:47 AM

Comments: Heat of Desorption experiment using ammonia.

First Order Kinetics Report

Experiment 1: 10 C/min
 Analysis type: Temperature Programmed Desorption
 Calibration: None
 Measured flow rate: 25.02 cm³ STP/min
 Signal offset: 0.07921
 Signal inverted: Yes

| Peak Table | | | | |
|-------------------|-----------------------------|------------------------|-----------------------|--------------------|
| Peak Number | Temperature at Maximum (°C) | Start Temperature (°C) | Stop Temperature (°C) | Ramp Rate (°C/min) |
| 1 | 374.3 | 124.1 | 488.6 | 10.0 |

Experiment 2: 5 C/min
 Analysis type: Temperature Programmed Desorption
 Calibration: None
 Measured flow rate: 25.04 cm³ STP/min
 Signal offset: 0.08117
 Signal inverted: Yes

| Peak Table | | | | |
|-------------------|-----------------------------|------------------------|-----------------------|--------------------|
| Peak Number | Temperature at Maximum (°C) | Start Temperature (°C) | Stop Temperature (°C) | Ramp Rate (°C/min) |
| 1 | 367.1 | 120.1 | 485.9 | 5.0 |

Experiment 3: 20 C/min
 Analysis type: Temperature Programmed Desorption
 Calibration: None
 Measured flow rate: 25.06 cm³ STP/min
 Signal offset: 0.08148
 Signal inverted: Yes

| Peak Table | | | | |
|-------------------|-----------------------------|------------------------|-----------------------|--------------------|
| Peak Number | Temperature at Maximum (°C) | Start Temperature (°C) | Stop Temperature (°C) | Ramp Rate (°C/min) |
| 1 | 385.9 | 120.7 | 485.8 | 20.0 |

SIGNAL VS. TEMPERATURE REPORT

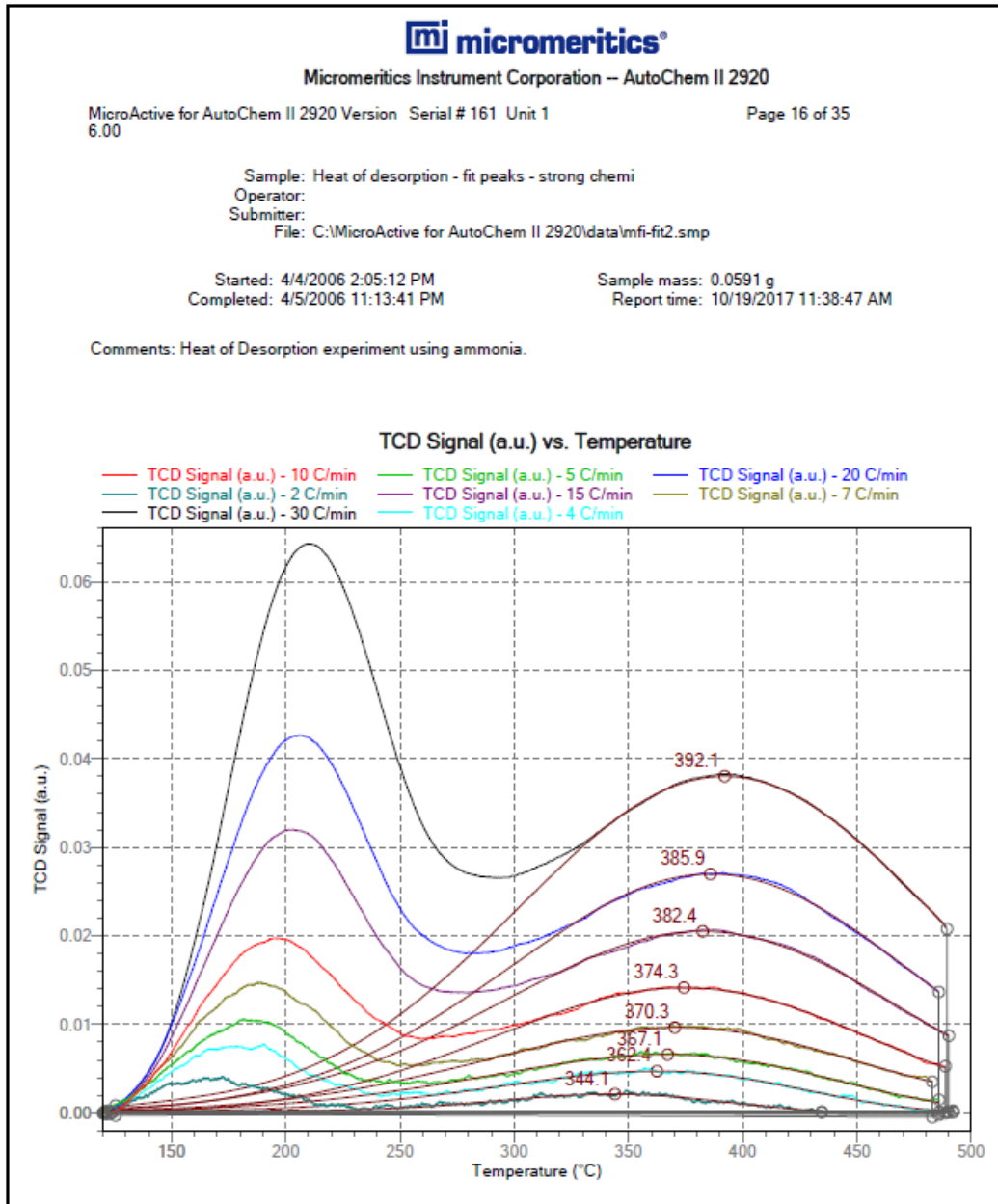

SIGNAL VS. TIME REPORT

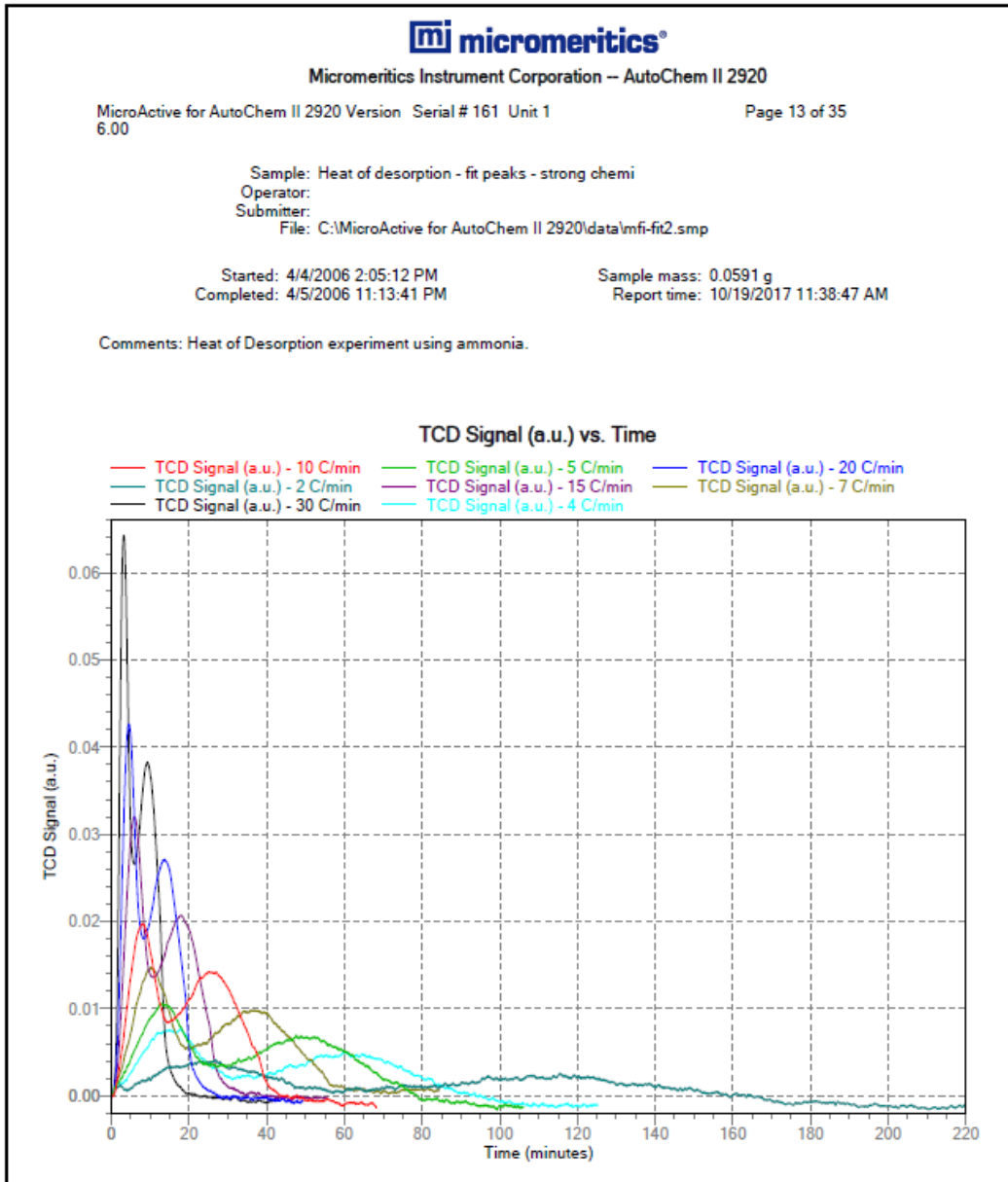

SUMMARY REPORT

|  | | | |
|---|-----------------------------|-------------------------------------|--------------|
| Micromeritics Instrument Corporation -- AutoChem II 2920 | | | |
| MicroActive for AutoChem II 2920 Version 6.00 | | Serial # 161 Unit 1 | Page 1 of 35 |
| Sample: Heat of desorption - fit peaks - strong chemi | | | |
| Operator: | | | |
| Submitter: | | | |
| File: C:\MicroActive for AutoChem II 2920\data\mfi-fit2.smp | | | |
| Started: 4/4/2006 2:05:12 PM | | Sample mass: 0.0591 g | |
| Completed: 4/5/2006 11:13:41 PM | | Report time: 10/19/2017 11:38:47 AM | |
| Comments: Heat of Desorption experiment using ammonia. | | | |
| Summary Report | | | |
| Experiment 1: 10 C/min | | | |
| Analysis type: Temperature Programmed Desorption | | | |
| Calibration: None | | | |
| Measured flow rate: 25.02 cm ³ STP/min | | | |
| Signal offset: 0.07921 | | | |
| Signal inverted: Yes | | | |
| Peak Number | Temperature at Maximum (°C) | Area | Peak Height |
| 1 | 374.3 | 0.26895 | -1.415e-02 |
| Experiment 2: 5 C/min | | | |
| Analysis type: Temperature Programmed Desorption | | | |
| Calibration: None | | | |
| Measured flow rate: 25.04 cm ³ STP/min | | | |
| Signal offset: 0.08117 | | | |
| Signal inverted: Yes | | | |
| Peak Number | Temperature at Maximum (°C) | Area | Peak Height |
| 1 | 367.1 | 0.24670 | -6.621e-03 |
| Experiment 3: 20 C/min | | | |
| Analysis type: Temperature Programmed Desorption | | | |
| Calibration: None | | | |
| Measured flow rate: 25.06 cm ³ STP/min | | | |
| Signal offset: 0.08148 | | | |
| Signal inverted: Yes | | | |
| Peak Number | Temperature at Maximum (°C) | Area | Peak Height |
| 1 | 385.9 | 0.25943 | -2.699e-02 |

**This page
intentionally
left blank**

7 SELECTED REPORTS



To edit reports, open the *Sample* file then select the *Report Options* tab. Highlight the report name in the *Selected Reports* list box and click **Edit**.

ADVANCED REPORTS - PYTHON MODULE

- **Summary reports.** Consist of summary sections, each containing a two-column table of label and value pairs. Summary reports are created with the *mic.summary* call.
- **Tabular reports.** Consist of one or more tables each containing one or more labeled columns of data. Tabular reports are created with the *mic.table* call.
- **Graphical reports.** Consist of a single graph with one or more curves on one or two y-axes. Graphical reports are created with the *mic.graph* call.

Calls for accessing the sample file data can be found in the *Mic Module Python Calls* section of this appendix. More advanced example python scripts are included in the analyzer software.

Advanced Reports

Up to five Advanced reports, each with up to 10 summary reports, 10 tabular reports, and 10 graphical reports can be created. To use this feature, a file containing a Python script that imports a "mic" Python module must be created. See [MicModule Python Calls on page A - 11](#) for an example of a Python script and functions for the "mic" Python module.

1. Create the Python script and save it in the *Scripts* directory.
2. Open a sample file with a *Complete* status.
3. Select *Advanced* in the view selector drop-down list at the bottom of the window to return to the tabbed view.
4. On the *Report Options* tab, select *Advanced* in the *Selected Reports* list box, then click **Edit**.
5. On the *Advanced Report Options* window, click **Add** in the *Available Scripts* group box to locate and select the Python script. Repeat for each script to be added.

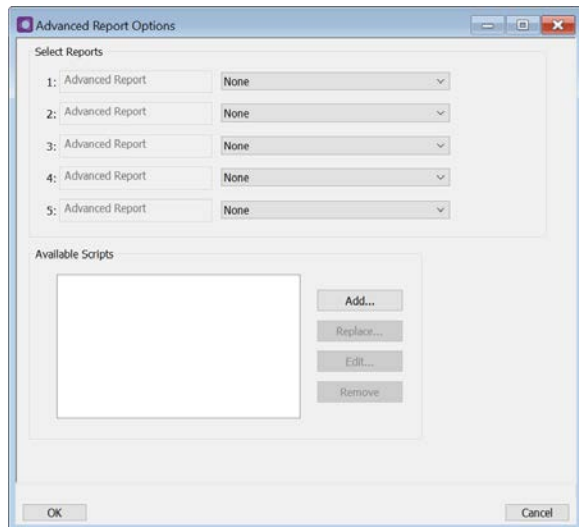

6. In the *Selected Reports* group box, click the drop-down arrows to select up to five Python scripts previously added in the *Available Scripts* box.
7. On the *Report Options* tab, click **Preview**. The Python Reports will be included on the tabs across the top portion of the *Reports* window.

Advanced Reports

| Selections | Description |
|--|--|
| Advanced Report 1 through 5 [drop-down box] | Use the drop-down lists to select currently-defined functions used to define the report calculations and output. |
| Available Scripts [group box] | Lists the available reports and provides the option to add, replace, edit, or remove reports. |
|  <p>For fields and buttons not listed in this table, see Common Fields and Buttons on page 2 - 4.</p> | |

BET SURFACE AREA REPORT

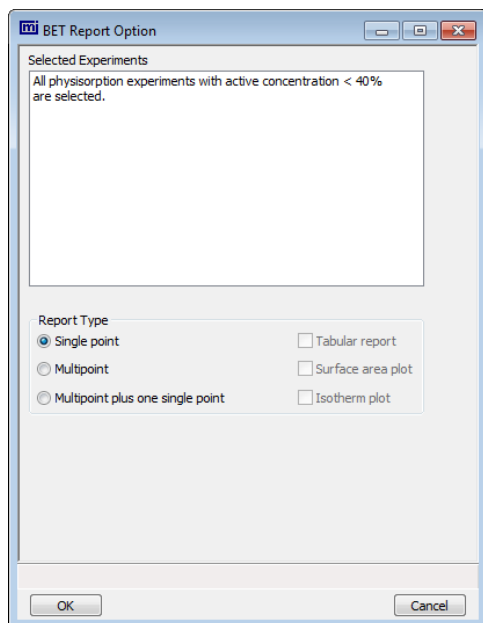

BET Report

| Selections | Description |
|---|--|
| Selected Experiments [group box] | Displays all related experiments in the current file. Deselect report options to exclude from the experiment. If this is a new file, no experiments are listed. Experiments are not included in the list until BET data are collected. |
| Report Type [group box] | Select the report types to generate. |
|  | For fields and buttons not listed in this table, see Common Fields and Buttons on page 2 - 4 . |

FIRST ORDER KINETICS REPORT

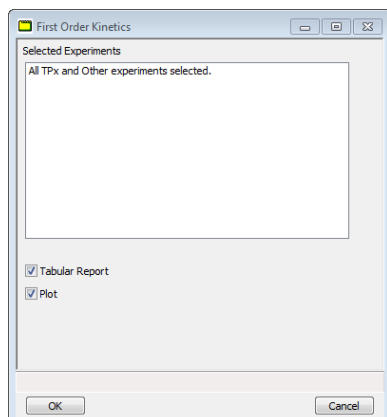

First Order Kinetics Report

| Selections | Description |
|---|--|
| Plot [<i>check box</i>] | Select to have the report formatted in a graph format. |
| Selected Experiments [<i>group box</i>] | Displays all related experiments in the current file. Only experiments with collected data are shown. |
| Tabular Report [<i>check box</i>] | Select to have report formatted in table format. |
|  | For fields and buttons not listed in this table, see Common Fields and Buttons on page 2 - 4 . |

GRAPH REPORT OPTIONS

- Input Signal [n] vs Temperature [n]
- Input Signal [n] vs Time [n]
- TCD Concentration vs. Temperature
- TCD Concentration vs. Time
- TCD Signal and Concentration vs. Time
- TCD Signal vs. Temperature
- TCD Signal vs. Time
- Temperature vs Time

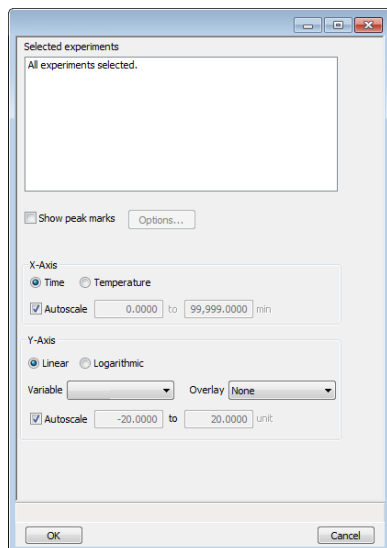

Any signal (the detector signal or the 1 or 2 auxiliary signal) may be plotted against time or temperature. Any signal can be overlaid onto the primary signal.

For color output to a monitor or printer, signals are displayed in different colors. For black and white output, different symbols are used.

Graph Report Options

| Selections | Description |
|------------------------------|---|
| Mass spec [group box] | Autoscale. When enabled on the report parameters windows, allows the x- and y- axes to be scaled automatically. <i>Autoscale</i> means that the x- and y- ranges will be set so that all the data is shown. If Autoscale is not selected, the entered range is used. |

Graph Report Options (continued)

| Selections | Description |
|--|--|
| Options [<i>button</i>] | <p>Enabled when the <i>Show peak marks</i> option is selected.</p> <p>Lists the peaks for the results of the highlighted experiment. Select any (or all) peaks to include in the graph.</p> <div data-bbox="555 464 938 947" style="border: 1px solid gray; padding: 5px; margin: 10px 0;"> <p>Peak Selection ×</p> <p>Available peaks</p> <div style="border: 1px solid gray; padding: 2px; min-height: 100px;"> <p>All peaks selected.</p> </div> <p>Label:</p> <p><input type="radio"/> Temperature</p> <p><input type="radio"/> Area</p> <p><input checked="" type="radio"/> None</p> <p style="text-align: center;"> <input type="button" value="OK"/> <input type="button" value="Cancel"/> </p> </div> <p>Select the peak labels to display on the graphs.</p> |
| Overlay [<i>group box</i>] | <p>Specify overlay options to include in the report.</p> |
| Selected Experiments [<i>group box</i>] | <p>Displays all related experiments in the current file. Only experiments with collected data are shown. This option is disabled for new files.</p> |
| Show peak marks [<i>check box</i>] | <ul style="list-style-type: none"> ■ Enables the Options button to specify the peaks to include in the experiment. ■ Displays the areas and baselines on the graph. ■ Draws a straight baseline between the selected peaks. |
| X-axis [<i>group box</i>] | <p>Specify <i>Time</i> or <i>Temperature</i> for the x-axis variable.</p> <p>Autoscale. When enabled on the report parameters windows, allows the x- and y- axes to be scaled automatically. <i>Autoscale</i> means that the x- and y- ranges will be set so that all the data is shown. If Autoscale is not selected, the entered range is used.</p> |

Graph Report Options (continued)

| Selections | Description |
|--|---|
| Y-axis [group box] | Specify <i>Time</i> or <i>Temperature</i> for the y-axis variable. Autoscale. When enabled on the report parameters windows, allows the x- and y- axes to be scaled automatically. <i>Autoscale</i> means that the x- and y- ranges will be set so that all the data is shown. If Autoscale is not selected, the entered range is used. Linear/Logarithmic. Scales the graph as <i>Linear</i> or <i>Logarithmic</i> . |
|  For fields and buttons not listed in this table, see Common Fields and Buttons on page 2 - 4 . | |

LANGMUIR REPORT

[BET Surface Area Report on page 7 - 3.](#)

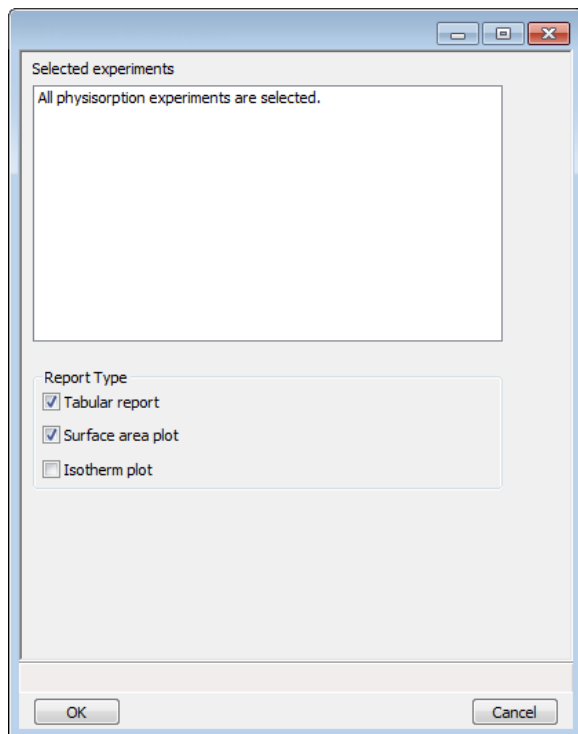

LOOP CALIBRATION REPORT

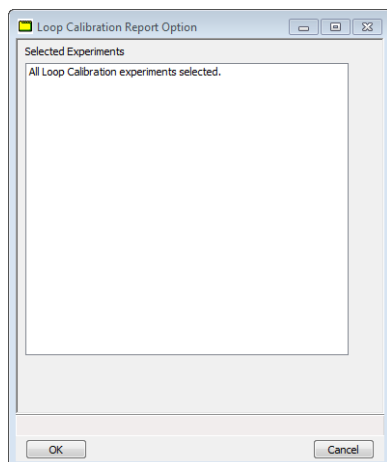

Loop Calibration Report

| Selections | Description |
|--|---|
| Selected Experiments [group box] | Displays all related experiments in the current file. Only experiments with collected data are shown. |
|  For fields and buttons not listed in this table, see Common Fields and Buttons on page 2 - 4. | |

OPTIONS REPORT

| |
|---|
|  Options reports cannot be edited. |
|---|

Options Report for AutoChem

Produces a printed report of predefined collection of sample file parameters.

- Active metals
- Analysis conditions
- Report options
- Sample information

Options Report for Chemisorption

Produces a printed report of a predefined collection of sample file parameters. If *Automatically collected* is selected in the *Type of Data* group box on the *Sample Description* tab, the following information is reported:

- **Task Summary.** Lists conditions specified for each task selected.
- **Analysis Task Options.** Details conditions specified for the analysis task.
- **Experiment Log.** Identifies actual conditions under which each task transpired.
- **Leak Test Results.** Identifies outgas rates and the outcome for each leak test performed.

Options Report for Physisorption

Lists the conditions used to perform the analysis such as:

- Adsorptive properties
- Analysis conditions
- Analysis method
- Degas conditions
- Free space
- Saturation pressure (P_0) and temperature

Options Report for Dynamic Analysis

Produces a printed report of predefined collection of sample file parameters.

Options Report for Mercury Porosimetry

The *Options* report for mercury porosimetry analyses lists the conditions used to perform the analysis— such as:

- | | |
|-------------------------|---------------------------|
| ▪ Analysis conditions | ▪ Mercury properties |
| ▪ Evacuation options | ▪ Penetrometer properties |
| ▪ High pressure options | ▪ Reverberi options |
| ▪ Low pressure options | ▪ Sample information |
| ▪ Material properties | |



Options reports cannot be edited.

Options Report for Pycnometry Analyzers

The *Options* report provides information on the sample, its material properties, and analysis conditions. This report cannot be edited.

OPTIONS REPORT

Produces a printed report of predefined collection of sample file parameters.

- Active metals
- Analysis conditions
- Report options
- Sample information

PULSE CHEMISORPTION REPORT

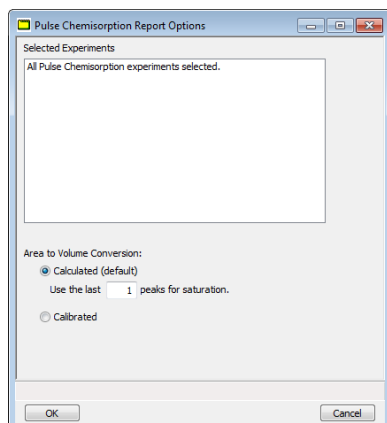

Pulse Chemisorption Report

| Selections | Description |
|--|--|
| Area to Volume Conversion [group box] | Calculated. Uses the standard calculation and the raw signal. Calibrated. Uses selected peaks for the conversion. A calibration step must be included in the experiment to use this method. |
| Selected Experiments [group box] | Displays all related experiments in the current file. Only experiments with collected data are shown. |
|  For fields and buttons not listed in this table, see Common Fields and Buttons on page 2 - 4. | |

Quantity Adsorbed Formulas

| Situation 1 | Pulse adsorption experiment, no calibration applied in peak editor, report option is <i>Calculated</i> . $Qads_x = \frac{L - (L \times \frac{Ax}{Avg_{lastN}})}{Mass_{sample}}$ |
|--------------------|---|
| Situation 2 | Pulse adsorption experiment, no calibration applied in peak editor, report option is <i>Calibrated</i> . Report displays an error message that calibration is not found and uses the formula from Situation 1. |
| Situation 3 | Pulse adsorption experiment, calibration is applied in peak editor, report option is <i>Calculated</i> . $Qads_x = \frac{Q_{end} - Q_x}{Mass_{sample}}$ |
| Situation 4 | Pulse adsorption experiment, calibration is applied in peak editor, report option is <i>Calibrated</i> . $Qads_x = \frac{L - Q_x}{Mass_{sample}}$ |
| Situation 5 | Pulse reaction experiment, no calibration applied in peak editor, report option is <i>Calculated</i> . $Qads_x = \frac{(L \times \frac{Ax}{Avg_{firstN}}) - (L \times \frac{A_{end}}{Avg_{firstN}})}{Mass_{sample}}$ |
| Situation 6 | Pulse reaction experiment, no calibration applied in peak editor, report option is <i>Calibrated</i> . Report displays an error message that calibration is not found and uses the formula from Situation 5. |
| Situation 7 | Pulse reaction experiment, calibration is applied in peak editor, report option is <i>Calculated</i> . $Qads_x = \frac{Q_x - Q_{end}}{Mass_{sample}}$ |
| Situation 8 | Pulse reaction experiment, calibration is applied in peak editor, report option is <i>Calibrated</i> . $Qads_x = \frac{Q_x - 0.0}{Mass_{sample}}$ |

where

- A_{end} = Area of the last peak, shown as *Peak Area* in peak editor
 A_x = Area of peak #X, shown as *Peak Area* in peak editor
 AVG_{firstN} = Average of first N peak areas
 AVG_{lasttN} = Average of last N peak areas
 L = Loop quantity calculated from the injection volume, ambient temperature, ambient pressure, and active gas concentration.

$$V_{inj} \times \frac{273.15}{T_{amb} + 273.15} \times \frac{P_{amb}}{760mm.Hg} \times \frac{C_{active}}{100.0}$$

- $Mass_{\text{sample}}$ = Sample mass (grams)
 N = Use the last N peaks for saturation in the Pulse Chemisorption Report Options. For pulse reaction experiments (where gas is emitted by the reaction and peak areas decrease over time) this is the first N peaks.
 $Qads_x$ = *Quantity Adsorbed per gram* for peak #X, shown in the Pulse Chemisorption Report's peak table. The report sets negative values to 0.0. To get total quantity adsorbed, multiply by $Mass_{\text{sample}}$ and sum across peaks.
 Q_{end} = Quantity of the last peak, shown as *Peak Quantity* in peak editor.
 Q_x = Quantity of peak #X, shown as *Peak Quantity* in peak editor

SUMMARY REPORT

The *Summary Report* for dynamic analyses provides a condensed summary of the peaks and selected analysis parameters.

TOTAL PORE VOLUME REPORT

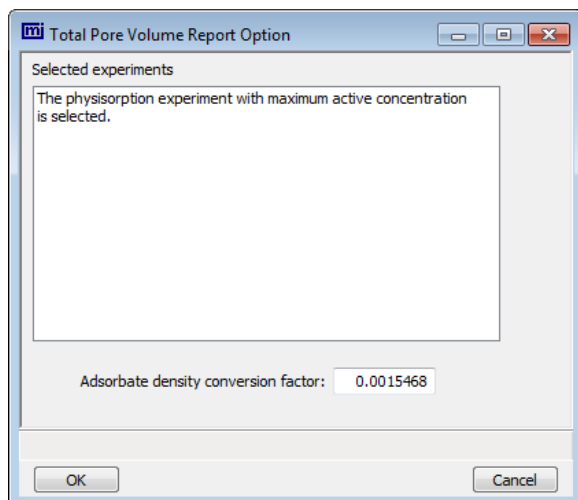

Total Pore Volume Reports

| Selections | Description |
|--|---|
| Selected Experiments [group box] | Displays all related experiments in the current file. Deselect report options to exclude from the experiment. If this is a new file, no experiments are listed. Experiments are not included in the list until BET data are collected. |
| Adsorbate density conversion factor [text box] | Enter the appropriate value for converting the gas volume to liquid volume. This value can be obtained by dividing the gas density by the liquid density at the adsorption temperature. $\text{Density conversion factor} = \frac{\rho_{gas}}{\rho_l} \times \frac{T_{bath}}{T_{STP}}$ |
|  For fields and buttons not listed in this table, see Common Fields and Buttons on page 2 - 4 . | |

**This page
intentionally
left blank**

8 CALIBRATION

Unit [n] > Instrument Calibration



A calibration file was created specifically for the analyzer and included with the accessories. It is not necessary to recalibrate the system unless it seems out of calibration.

Disabled calibration menu options can be accessed only with the assistance of an authorized Micromeritics Service Representative. Calibrations can be saved to a file and reloaded later.



Generally, it will not be necessary to change the data in the calibration file. However, if a condition occurs during the operational verification that requires changes to the calibration data, changes should be saved in a file. Calibration data files are retained in the analyzer history file and can be reloaded in the event that calibration data becomes corrupt.

| | Detector Heat Zone | Cold Trap Heat Zone | Analyze Heat Zone | Loop Heat Zone | |
|------------|--------------------|---------------------|-------------------|----------------|--|
| Reading | 99.0 | 99.0 | 99.0 | 99.0 | |
| Low Cal. | 20 | 20 | 20 | 20 | |
| High Cal. | 150 | 150 | 150 | 150 | |
| Calibrated | | | | | |
| Raw Value | 12345 | 12345 | 12345 | 12345 | |

| | Sample Temperature * | Sample Pressure * | Auxiliary Input1 | Auxiliary Input2 | Furnace Temperature * |
|------------|----------------------|-------------------|------------------|------------------|-----------------------|
| Reading | 251.0 | 760 | 1.23 | 4.56 | 251.0 |
| Low Cal. | -160 | 760 | -15.0 | -15.0 | 0 |
| High Cal. | 1.000 | 2.586 | 15.0 | 15.0 | 1.100 |
| Calibrated | | | | | |
| Raw Value | 12345 | 123 | 1234 | 1234 | 12345 |

* Be sure not to exceed recommended temperatures and pressures for the type of sample tube in use.

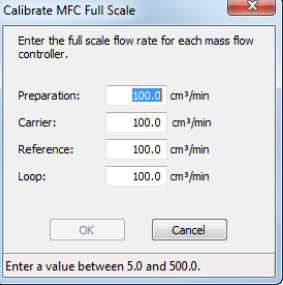
Calibration

| Selections | Description |
|---|--|
| Accept [<i>button</i>] | Replaces the existing calibration values with those entered. |
| Load from File [<i>button</i>] | Loads a different calibration file. |
| MFC Full Scale [<i>button</i>] |  <p data-bbox="553 730 1442 806">Displays the full scale flow rate for the mass flow controllers. The full scale was determined using H₂ as the calibration gas.</p> |
| Save to File [<i>button</i>] | Saves the current calibration settings to a file. |
|  <p data-bbox="349 903 1323 976">For fields and buttons not listed in this table, see Common Fields and Buttons on page 2 - 4.</p> | |

GAS CONCENTRATION CALIBRATION

[Sample Files on page 3 - 2](#)

After performing an analysis, peak area data can be converted to volume data. The application can perform this conversion when additional information is provided.

In some cases (such as in TPR analyses), the analyzer needs to know how to correlate the signal readings collected in the analysis with the volume of gas uptake at any given point in the analysis. If the analyzer is provided with a series of known gas concentrations, and it records the signal associated with each known concentration, then it can use this information to calculate the concentrations associated with the signals it recorded during the analysis. From that point, it can also calculate the volume of gas associated with each peak in the data.

1. Prepare and install a clean, empty sample tube.
2. Ensure the correct gases are connected.
3. Create the sample file:
 - a. Go to **File > New Sample**.
 - b. Complete the fields on the *Sample Description* tab as needed.
4. Select the *Analysis Conditions* tab.
5. Click **Insert** and select *Gas Calibration*.
6. Click **OK**.

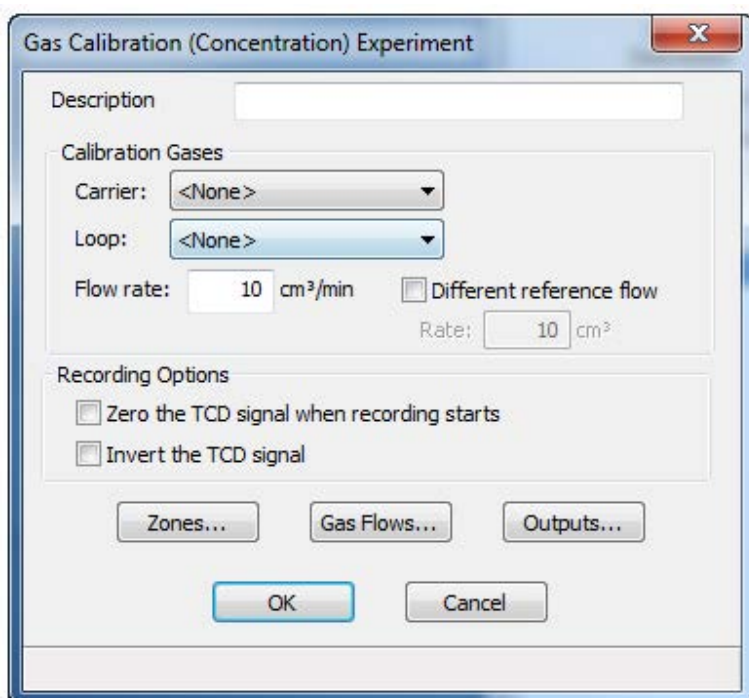

7. Select *Hydrogen-Argon* for Carrier.
8. Select *Argon* for Loop.
9. Enter *50* as the *Flow rate*.
10. Click **Zones** to set the temperature for the analyzer's heated zones.
11. Complete the fields in the *Set Temperature Zones* window using the following table:

Set Temperature Zones Settings

| Field | Enter |
|------------|--------|
| Analysis | 110 °C |
| Block Zone | 100 °C |
| Cold Trap | 110 °C |
| Filament | 175 °C |

12. Click **OK** to close the *Zones* window.
13. Click **OK** again to close the *Calibration* window.
14. Click **Save As**, provide a new file name, then click **Close**.
15. Go to **Unit [n] > Sample Analysis**.
16. Click **Browse** to locate sample file previously created.
17. Click **Next** three times in this sample file.
18. Click **Start** to start the analysis. Use the other views of the analysis window to observe the progress of the analysis.

During the automatic analysis, the analyzer decreases the proportion of the analysis gas in 10% increments, beginning with 100% and ending with 0%. The resultant data should appear as a series of ten stepwise changes in the TCD signal.

19. When the analysis ends, close the *Analysis* window.
20. When the displayed sample temperature reaches the ambient temperature, open the furnace and remove the sample tube.
21. Go to **Options > Signal Calibration > Open**. Select the calibration file, then click **OK**.
22. Click **Load Calibration Data** then select the sample file for this calibration, then click **OK**.
23. Click **OK**. The data in the sample file are automatically inserted into the appropriate fields of the *Signal Calibration* window



Use the cotton gloves provided in the accessory kit when handling heated surfaces. These cotton gloves are not intended to protect hands when heated surfaces are above 60 °C.

24. Assess the data listed in the table. In the *Concentrations* column, enter the starting and ending gas mixture percentages. The application calculates the percentages for the rest of the table.

25. Assess the gas concentration plot, Goodness of Fit, and Coefficients to determine if the calibration file is acceptable. Use your laboratory's standards to determine what level of linearity is acceptable. As a general guideline, use a calibration file with a very low value for Goodness of Fit (less than 1/2% of the maximum concentration) when 1st or 2nd Degree is specified.

Data points that deviate significantly from linear can be deleted. Evaluate the results when the degree is changed (select a different degree from the drop-down list).

26. When satisfied with the calibration file, enter a descriptive name in the *Description* field.
27. Click **Save**, then click **Close**.
28. Go to **Options > Signal Calibration > Report** to select a report to generate.

GAS FLOW CALIBRATION

Unit [n] > Gas Flow Calibration

[Gas Charts on page E - 1](#)

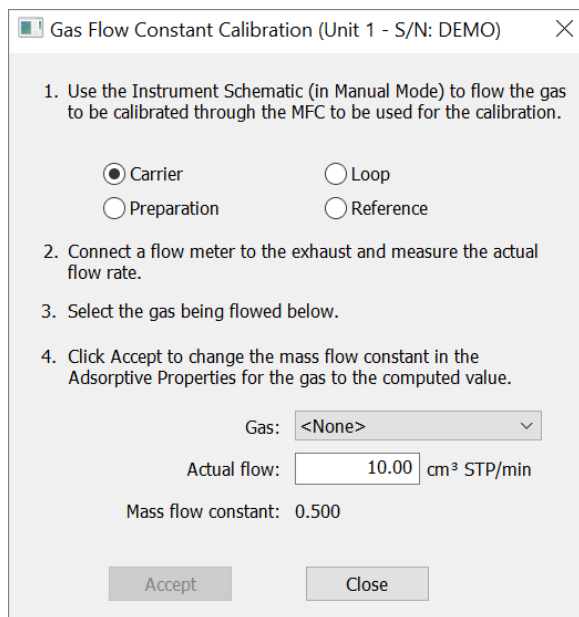

Gas Flow Constant Calibration (Unit 1 - S/N: DEMO)

1. Use the Instrument Schematic (in Manual Mode) to flow the gas to be calibrated through the MFC to be used for the calibration.

Carrier Loop
 Preparation Reference

2. Connect a flow meter to the exhaust and measure the actual flow rate.
3. Select the gas being flowed below.
4. Click Accept to change the mass flow constant in the Adsorptive Properties for the gas to the computed value.

Gas: <None>

Actual flow: 10.00 cm³ STP/min

Mass flow constant: 0.500

Accept Close

Use the *Gas Flow Constant Calibration* option to determine a constant used by the analyzer to ensure accurate gas flows through each Mass Flow Controller (MFC). The Mass Flow Controllers were calibrated before shipping and calibration is typically not necessary.

1. Go to **Unit [n] > Enable Manual Control**. Ensure a checkmark displays to the left of the menu item. If the analyzer schematic does not display, go to **Unit [n] > Show Instrument Schematic**. Flow the gas to be calibrated through MFC to be used for the calibration.
2. Connect a flow meter to the exhaust and measure the actual flow rate.
3. In the *Gas* drop-down box, select the gas to be flowed. In the *Actual flow* field, enter the actual flow rate to compute the mass flow constant.
4. Click **Accept** to change the mass flow constant in the *Adsorptive Properties* for the gas to be the computed value.

SIGNAL CALIBRATION FOR DYNAMIC ANALYSIS

Analyses yield data on signal reading, peak area, temperature, and time. These data are sufficient for many applications; however, volume data may also be needed.

It is not necessary to perform a calibration if volume data are not needed. If volume data are needed, calibration may be performed either before or after the analysis.



This does **not** apply to loop calibration, ambient temperature, and atmospheric pressure.

A group of automatic calibration routines is provided in the form of specialized experiment steps. A calibration run is an analysis using one of these experiment steps. The calibration run can be performed before or after the sample analysis. It can be included as a step within the analysis, or performed as a separate analysis.

After the sample data and calibration data are collected, the calibration file is associated with the sample file, and the sample data are converted to volume. A single calibration run can be associated with an unlimited number of sample data files. For example, TPR yields peak area and the temperature at which maximum reduction occurs. To obtain the volume of gas uptake, a calibration file must be associated with the analysis file. Then, reports are created in which the area data are converted to volume data.

A calibration file can be associated with a sample file by doing the following:

- Using the default file or choose a different file in the *Unit [n] > Sample Analysis* window.
- Clicking **Set Calibration** on the *Peak Editor* window and select from a list of calibration files created after the sample file was used in an analysis.

CREATE A NEW SIGNAL CALIBRATION FILE

Options > Signal Calibration > New

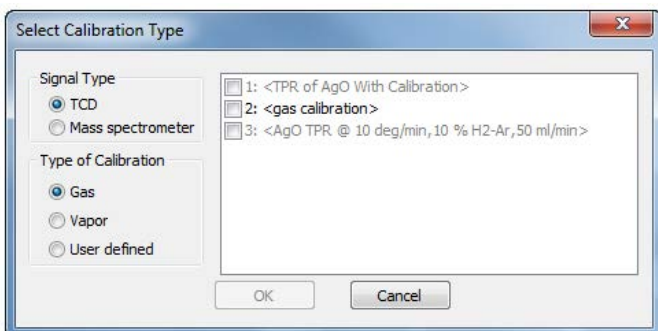

When selecting a *Signal Type* and *Type of Calibration*, only those options used in the original analysis are enabled on the right side of the window.

1. Select the sample file to use for the new signal calibration file.
2. Select the *Signal Type* and *Type of Calibration* options to include in the new calibration file. As selections are made, the experiments from the selected analysis file display on the right side of the window. Only those experiments applicable to the selected signal type and calibration type are enabled. Click **OK**.
3. If prompted, enter the active gas concentration in the carrier gas and loop gas. Click **OK**.
4. Delete (or edit) data in the *Peak Table* as appropriate. Click **Save**.

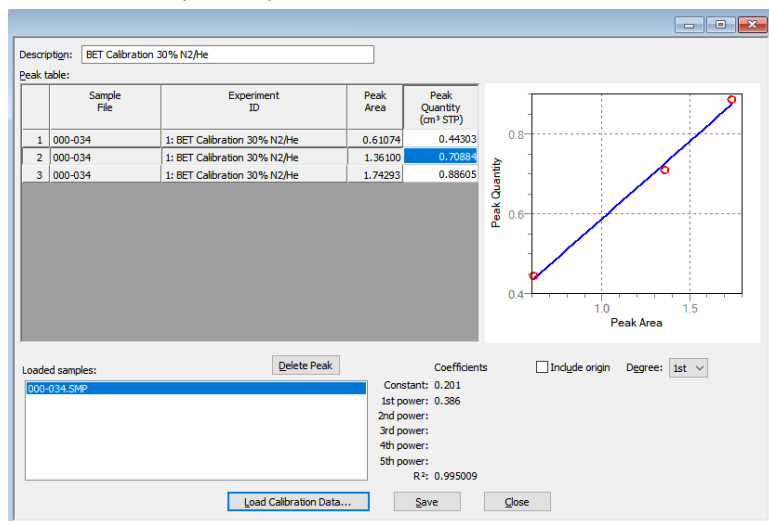

Signal Calibration

| Selections | Description |
|--|--|
| Degree [<i>drop-down box</i>] | Select the power to display in the <i>Coefficients</i> list. |
| Delete Peak [<i>button</i>] | Removes a peak from the peak table. Select the peak and click Delete Peak . |
| Description [<i>text box</i>] | Enter a description of the file. |
| Include origin [<i>check box</i>] | Enables or disables the original in the graph. |
| Load Calibration Data [<i>button</i>] | Use to enter calibration data from a selected file. |



For fields and buttons not listed in this table, see [Common Fields and Buttons on page 2 - 4](#).

CREATE A SIGNAL CALIBRATION REPORT

Options > Signal Calibration > Report

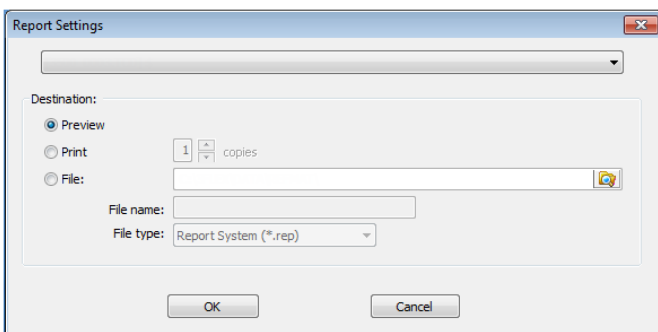

Select a previously defined signal calibration file from the drop-down list, then select the print destination.

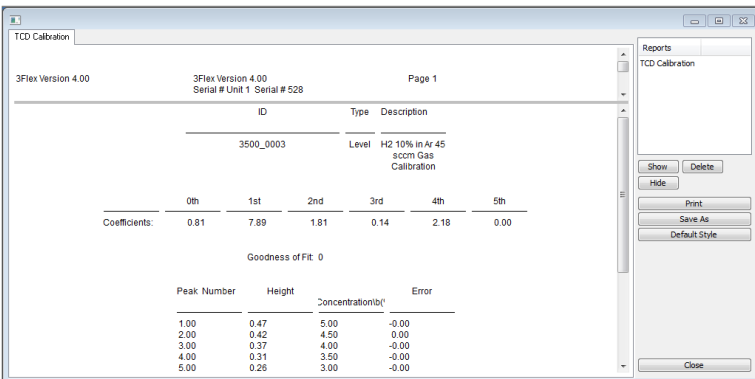

| ID | Type | Description |
|-----------|-------|--|
| 3500_0003 | Level | H2 10% in Ar 45 30cm Gas Calibration |

| | 0th | 1st | 2nd | 3rd | 4th | 5th |
|---------------|------|------|------|------|------|------|
| Coefficients: | 0.81 | 7.89 | 1.81 | 0.14 | 2.18 | 0.00 |

Goodness of Fit: 0

| Peak Number | Height | Concentration(ppm) | Error |
|-------------|--------|--------------------|-------|
| 1.00 | 0.47 | 5.00 | -0.00 |
| 2.00 | 0.42 | 4.50 | 0.00 |
| 3.00 | 0.37 | 4.00 | -0.00 |
| 4.00 | 0.31 | 3.50 | -0.00 |
| 5.00 | 0.26 | 3.00 | -0.00 |

OPEN A SIGNAL CALIBRATION FILE

Options > Signal Calibration > Open

Select a previously defined signal calibration file from the drop-down list. If a calibration file already exists, select the serial number from the drop-down serial number list. When a new calibration file is saved with a new serial number, the new serial number displays in the *Serial Number* drop-down list.

If this is the first calibration file to be saved, the *Serial Number* drop-down will not display until the first calibration file is saved.

LIST SIGNAL CALIBRATION FILES

Options > Signal Calibration > List

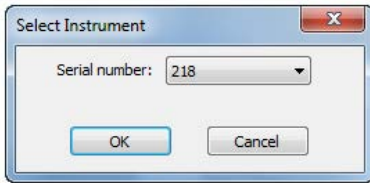

Displays a list view of previously defined signal calibrations for the selected serial number.

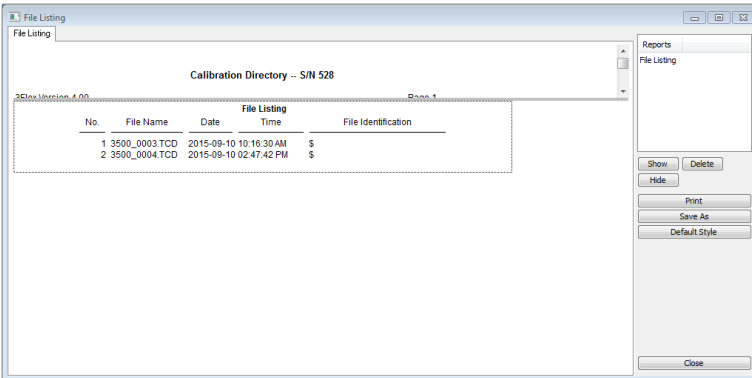

VAPOR CALIBRATION



Values and screen shots in this topic are for a typical vapor calibration for pyridine.

When using the optional vapor generator, it must be calibrated for the type of vapor to be used. Associating the analysis data with a vapor generator calibration file allows the conversion of peak area data to volume data. The calibration can be performed either before or after performing the analysis. A single calibration file can be used with multiple analysis files.

1. Go to **File > Open > Sample information**. Enter a calibration file name (.CAL). Click **OK**, then click **Yes** to confirm.
2. Complete the remaining fields on the *Sample Description* window as needed.



If the window displays in *Basic* presentation, click *Advanced* in the view selector drop-down at the bottom of the window.

3. Select the *Analysis Conditions* tab. Click **Insert**, then select *Vapor Calibration*.

4. Complete the window using these entries:

| Selections | Description |
|---|--|
| Calibration Gases [group box] | Select <i>Helium</i> . Enter a flow rate of 50 for each. |

| Selections | Description | |
|---|--|--------------|
| Reflux Temperatures [group box] | Enter a minimum of 70 and maximum of 80. | |
| Flask Temperatures [group box] | Enter a minimum of 80 and maximum of 100. | |
| Number of steps [text box] | 5 | |
| Recording Options [group box] | Select the signal. It is a good idea to select this option when using helium for the carrier gas. It improves the performance of automatic peak picking. | |
| Zones [button] | Field | Enter |
| | TCD Detector | |
| | Block zone | 100 |
| | Filament | 175 |
| | Valve Zones | |
| | Cold trap | 110 |
| | Analysis | 110 |
| | Loop | 110 |
| | Vapor generator | 20 |
| | Vapor Generator | |
| | Reflux | 20 |
| | Flask | 20 |
| Outputs [button] | See Auxiliary Inputs and Outputs on page C - 1 . | |

5. Click **OK** to close the *Set Temperature Zones* window, then again to close the *Vapor Calibration Experiment* window.
6. Click **Save As**, enter a file name, then click **Close**.
7. Go to **Unit [n] > Sample Analysis**. Click **Browse** and select the sample file just created.
8. Click **Next** three times to accept the values contained in this sample file. These values can be edited, however, no changes are needed for this example. Click **Start**.
9. Use the other views of the *Analysis* window to observe the progress of the analysis.
10. When the analysis completes, close the *Analysis* window.

11. When the displayed sample temperature reaches the ambient temperature, open the furnace. Use gloves and remove the sample tube. These fields do not require editing; the *Reflux* and *Flask* temperatures entered on the *Vapor Calibration Experiment* window are used.
12. To edit the calibration file, go to **Options > Signal Calibration > New**.



Use the cotton gloves provided in the accessory kit when handling heated surfaces. These cotton gloves are not intended to protect hands when heated surfaces are above 60 °C.

- a. Select *Load Calibration Data* and select the sample file for this calibration; the data contained in the file are automatically loaded.
- b. Access the *Calculations* document on the Micromeritics web page (www.micromeritics.com) for information on calculating the volume of each vapor injection, then enter the values for each peak.
- c. Assess the plot, *Goodness of Fit*, and *Coefficients* to decide if the calibration file is acceptable. Use your laboratory's standards to determine what level of linearity is acceptable. As a general guideline, use a calibration file with a very low value for *Goodness of Fit* (less than 1 to 2% of the signal), when 1st or 2nd Degree is specified.
- d. To delete any peaks that are outliers, highlight the peak data in the table and click **Delete Peak**. Evaluate the results when the degree is changed (select a different degree from the drop-down list).
- e. When satisfied with the calibration file, click **Save** then click **Close**.

LOAD CALIBRATION FROM FILE

Unit [n] > Calibration > Load from File

Use to load a previously saved calibration file.

It is recommended that the current calibration settings be saved using **Unit [n] > Calibration > Save to File** prior to loading another calibration file. When loading a previously saved calibration file, a backup of the current file is created and saved as [SN]/ast.cal. The backup file is overwritten each time a new one is created.



Changing the calibration may affect the analyzer's performance.

SAVE CALIBRATION TO FILE

Unit [n] > Calibration > Save to File

Use to save the current calibration settings to a backup file which can later be reloaded using the **Unit [n] > Calibration > Load from File** menu option.

The default file naming convention for calibration files can be used or the file name can be changed. The default file name of 0217-2013-04-25.CAL is interpreted as:

| | |
|-------------------|-------------------------------------|
| 0217 | Analyzer serial number |
| 2013-04-25 | Date the calibration file was saved |
| .CAL | File name extension |

**This page
intentionally
left blank**

9 HARDWARE

The analyzer has been designed to provide efficient and continuous service; however, certain maintenance procedures should be followed to obtain the best results over the longest period of time. When unexpected results occur, some common operational problems not indicated on the window and their respective causes and solutions are provided.

The following can be found on the Micromeritics web page (www.micromeritics.com).

- CryoCooler II and CryoCooler III Operator Manual (PDF)
- Error Messages document (PDF)
- Parts and Accessories

COLD TRAP TUBE OR DELAY PATH

A Cold Trap option is available. Parts and accessories are located on the [Micromeritics](http://www.micromeritics.com) web page. The cold trap or delay path is installed in the ports located under the top panel, to the left of the sample tube ports.

- A *cold trap* is used to condense liquids out of the gases flowing through the analyzer before reaching the detector.
- A *delay path* is used to reduce the perturbation (disturbance) of the gas flow caused by injections of gas through the septum.



- A. Diversion ports
- B. Cold trap or Delay path (cold trap shown)

1. Insert the open ends of the cold trap or delay path into the openings under the upper panel. If difficult to insert, loosen the attachment nuts by unscrewing them slightly.

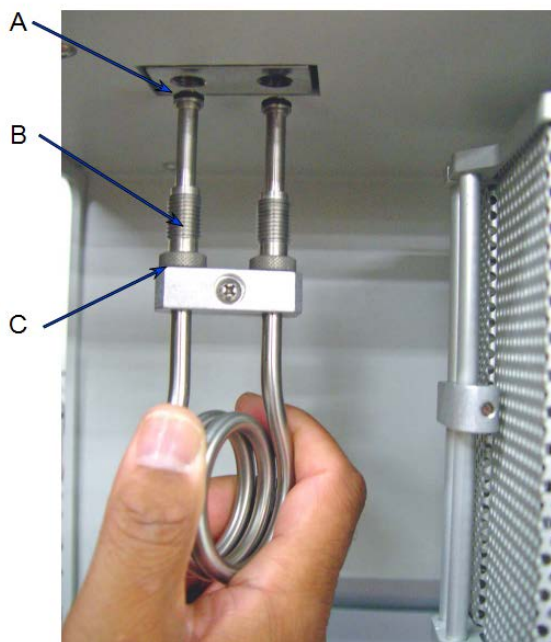

- A. O-ring
- B. Ferrule
- C. Retaining nut

NOTE: The same components are used with the delay path



If the nuts are loosened until they become free of the analyzer, they will fall out of the analyzer.

2. Press the cold trap or delay path up into the analyzer until it comes to a stop. Securely tighten the fittings.



Do not overtighten the fittings. A sufficient seal is achieved when the fittings are finger tight.

3. The use of a Dewar reduces the temperature of the cold trap. To use a Dewar:
 - a. Fill the Dewar with the appropriate coolant.
 - b. If using the Dewar shelf, hook the shelf on the front of the analyzer and slide the shelf to the right. Position the Dewar beneath the cold trap and raise the Dewar until the shelf can be moved to the left underneath the Dewar. Lower the Dewar to rest on the shelf.
 - c. If using the Dewar stand, position the Dewar beneath the cold trap and raise the Dewar until the stand can be moved underneath the Dewar. Lower the Dewar to rest on the stand.
 - d. Ensure the cold trap is completely immersed in the coolant.

CHANGE OR CLEAN THE COLD TRAP OR DELAY PATH

The cold trap removes condensibles from the gas stream, therefore it will require occasional cleaning. The delay path (used for BET analyses) also attaches to the cold trap port fittings.

1. If a Dewar is around the cold trap, raise the Dewar slightly, move the Dewar stand out of the way, and remove the Dewar. Allow the cold trap to warm to room temperature.



Depending upon the state of the analyzer, the cold trap fittings may be hot. Use the cotton gloves provided in the accessory kit when handling heated surfaces. These cotton gloves are not intended to protect hands when heated surfaces are above 60 °C.

2. Go to **Unit [n] > Enable Manual Control**. Ensure a checkmark displays to the left of the menu item. If the analyzer schematic does not display, go to **Unit [n] > Show Instrument Schematic**. Right-click on the cold trap valve and select *Bypass*.

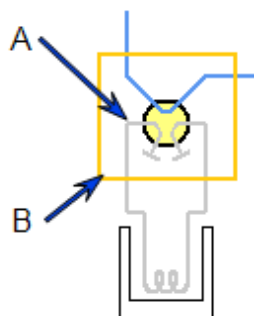

- A. Cold trap valve
- B. Cold trap heat zone

3. Loosen the retaining nuts on the cold trap port fittings.

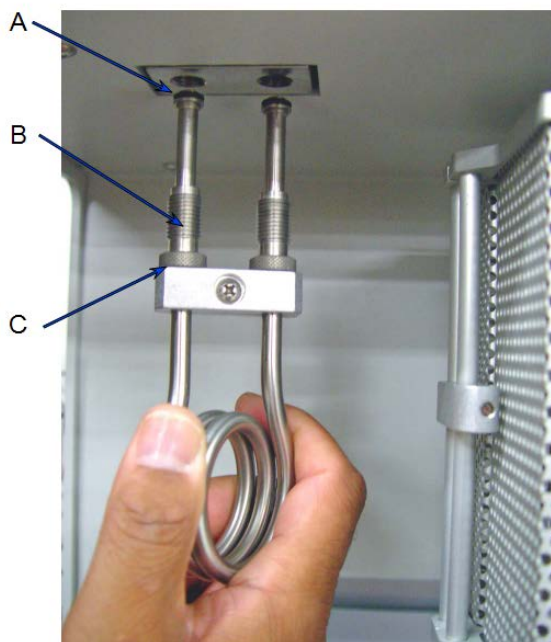

- A. O-ring
- B. Ferrule
- C. Retaining nut

NOTE: The same components are used with the delay path

4. Remove the cold trap (or delay path), nuts, ferrules, and O-rings.
5. Clean the cold trap (or delay path) by flushing it with isopropyl alcohol (IPA). Dry the trap in an oven or by blowing compressed air or nitrogen through it before replacing it.
6. Inspect the O-rings for cracks or other damage that might cause leaks. If the O-rings are cracked or damaged, replace them before reinstalling the cold trap (or delay path). Otherwise, clean, dry, and re-install the O-rings.



Use only Kalrez O-rings. Kalrez is rated for both chemical and temperature suitability in this application. O-rings of other materials could burn, melt, or decompose.

7. Place the retaining nuts, ferrules, and O-rings on the cold trap (or delay path).



Do not over tighten the retaining nuts. Doing so may damage the O-rings. Finger tight is sufficient.

8. Hold the cold trap (or delay path) in place and tighten the retaining nuts. Tighten the nuts only enough to hold the cold trap securely in place and prevent leaks.

FURNACE

When performing BET analyses, the furnace must be removed to allow placement of a cold bath Dewar around the sample.



The equipment images in this topic may differ slightly from your equipment; however, the instructions are the same unless otherwise noted.

FURNACE REMOVAL



Use the cotton gloves provided in the accessory kit when handling heated surfaces. These cotton gloves are not intended to protect hands when heated surfaces are above 60 °C.

1. Unplug the furnace power plug and the thermocouple cable from the analyzer

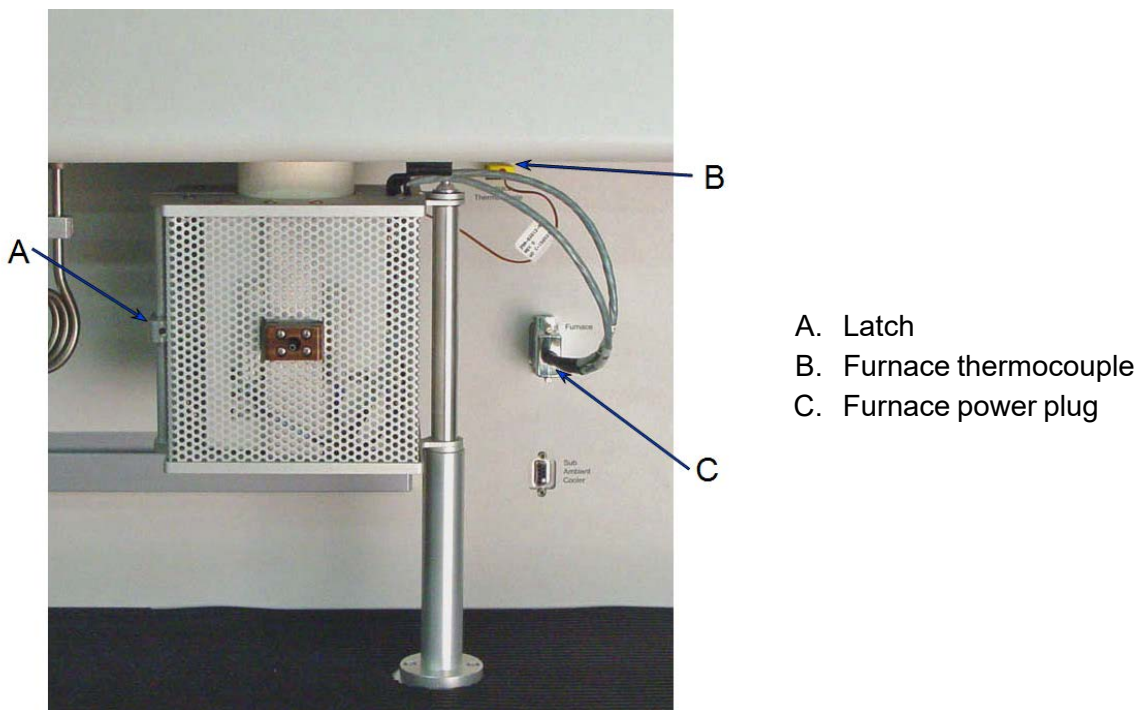

2. Release the latch on the left side of the furnace, then open the furnace.

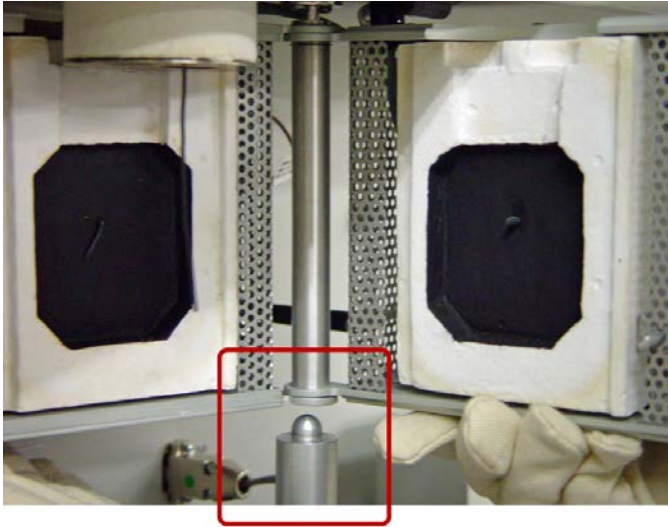

Support post

3. Gently lift the right side of the furnace until it is free from the support post.

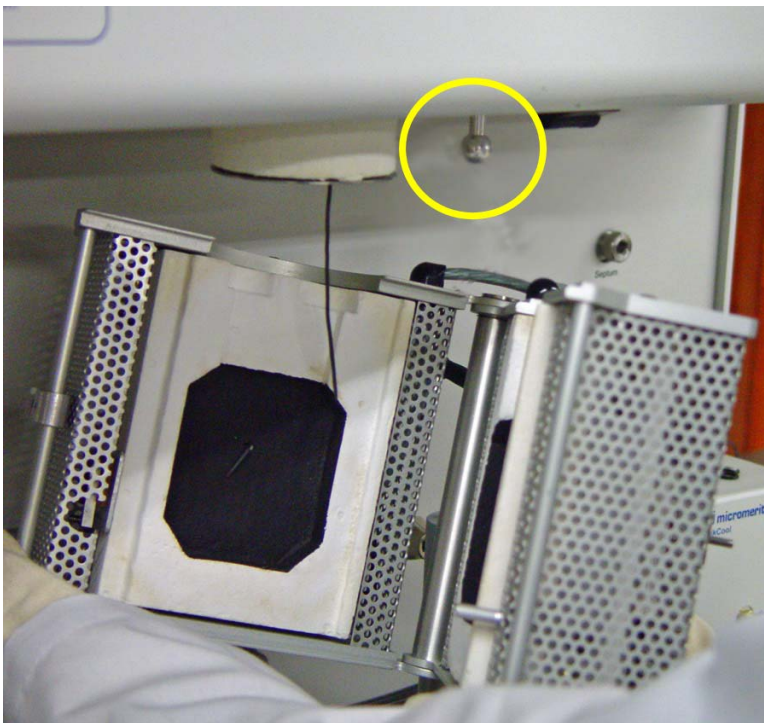

Retaining knob

4. Lower the furnace, moving it away from the support post until it is free of the retaining knob.
5. Close the furnace and secure the furnace latch. Place the furnace in a location where it will be protected from damage.

FURNACE INSTALLATION



The equipment images in this topic may differ slightly from your equipment; however, the instructions are the same unless otherwise noted.

1. Hold the open furnace next to the furnace support post. Lift the furnace, moving it above the support post until the retaining knob is inserted in the hole in the top of the furnace.

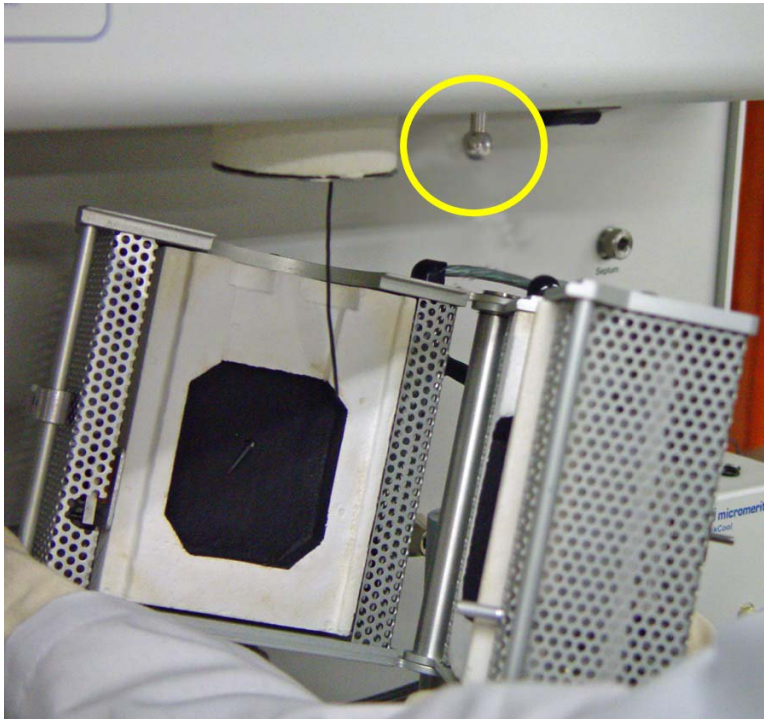

Retaining knob

2. When the retaining socket on the bottom of the furnace is located above the support post, gently lower the furnace until it rests securely on the post.

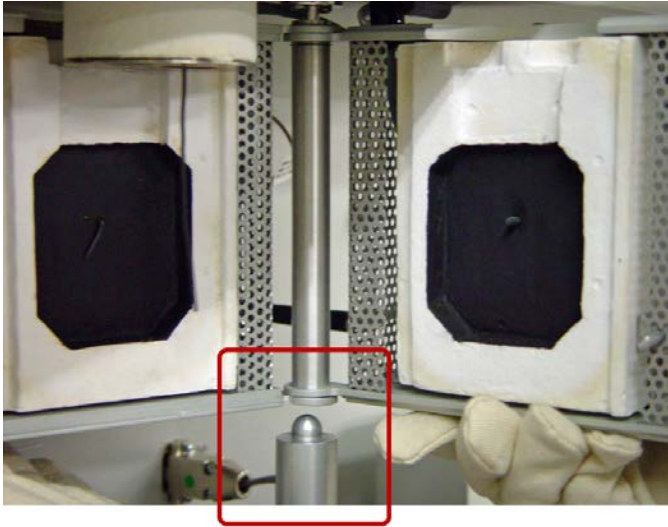

Support post

3. When ready to begin the experiment, close the furnace around the sample tube and secure the latch.
4. Plug the thermocouple cable and the furnace power cable into the appropriate connectors on the analyzer. . These connectors are located on the recessed front panel.

KwikCool

A KwikCool unit allows the furnace to cool quickly between analyses.



1. Power OFF the analyzer.
2. Attach the KwikCool cable to the connector labeled *Sub Ambient Cooler* on the front panel of the analyzer.
3. Attach the tubing provided to the inlet on the front of the furnace.
4. Attach a supply of dry house air (or nitrogen) to the gas inlet on the front of the KwikCool. The pressure is indicated next to the inlet.
5. Fill a Dewar with an ice water bath.
6. Place the KwikCool on top of the Dewar.



- A. Gas inlet
- B. Dewar
- C. Subambient cooler connector

7. Power ON the analyzer and start the analysis application.
8. In the experiment, select the *Enable KwikCool* option in the *Temperature Ramp* window.

KWIKCOOL VORTEX INSTALLATION



The optional KwikCool Vortex uses compressed air to generate a sub ambient supply of air to the furnace to allow rapid cooling.

This kit includes:

- 1 KwikCool unit
- 1 Clear urethane tube to connect to clean dry compressed air
- 1 Swagelok fitting to connect the Vortex Cooler to the urethane tube for the supply of clean dry compressed air

To install the KwikCool Vortex:

1. Connect the KwikCool Vortex electrical cable to the front panel of the analyzer at the connector labeled *Sub Ambient Cooler*.
2. Push the flexible hose from the front of the KwikCool Vortex onto the short metal tube at the center front of the furnace.
3. Connect the compressed air tubing to the Swagelok fitting and then connect the Swagelok fitting to the 1/4 in. tube on the front of the KwikCool Vortex.
4. Connect the other end of the compressed air tubing to any clean, dry compressed air supply, at approximately 100 psig. Do not exceed 120 psig.



Do not exceed 120 psig. The KwikCool Vortex system uses about 2 cfm of air when running. Nitrogen or other inert gas may also be used. If a gas cylinder is used, the KwikCool Vortex will consume the cylinder of gas quickly, depending on the cylinder size.

5. Restart the analyzer application so the application will recognize the new hardware.

MASS FLOW CONTROLLER CALIBRATION

Gas Charts on page E - 1

The analyzer uses a Mass Flow Controller (MFC) to control the flow of gases. The MFC requires a conversion constant for each gas or gas mixture to compensate for variations in gas flows resulting from variations in the gas properties.

In most cases, the default MFC conversion constant yields accurate data. A new conversion constant may be used if:

- A unique gas mixture is used.
- The gas to be used is not included in the table.
- A higher precision calibration of the MFC for a given gas is required.
- Unexpected analysis data lead you to believe that the default value is in error.

FLOW MEASUREMENT

An external device that measures the flow of gas from the analyzer's exhaust is used during MFC calibration. A soap bubble burette is such a device.

For even more precise calibration, use another type of flow meter and follow these instructions for obtaining a new conversion constant, substituting your flow meter for the soap bubble burette.

INSTALL A SOAP BUBBLE BURETTE OR OTHER TYPE OF FLOW METER



These instructions are for assembling and using a burette obtained from Micro-meritics. If using another type of flow meter, follow the meter manufacturer's assembly and operation instructions.

1. Carefully unwrap the glass tube and the rubber bulb.
2. Attach one end of the flexible tubing to the side arm of the glass tube.
3. Attach the metal tubing provided with the bubble burette to the other end of the flexible tubing.

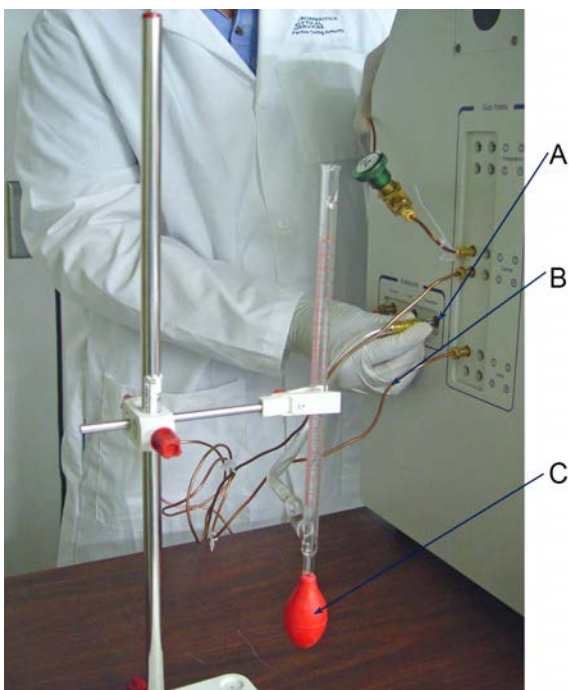

- A. Exhaust port
- B. Flexible tubing
- C. Bulb filled with leak detector

4. Locate the exhaust port that corresponds to the MFC to be used for this calibration.
5. Remove external plumbing from that port and attach the bubble burette using the connector provided with the burette. The soap bubble burette must be held in an upright position. For example, if using the Carrier Flow Controller, attach the bubble burette to the carrier gas exhaust port.
6. Attach the bulb to the bottom of the glass tube.

DETERMINE THE GAS FLOW CONSTANT FOR INDIVIDUAL GASES

Unit [n] > Gas Flow Calibration

1. Go to **Unit [n] > Enable Manual Control**. Ensure a checkmark displays to the left of the menu item. If the analyzer schematic does not display, go to **Unit [n] > Show Instrument Schematic**.
2. Flow the gas to be calibrated through the Carrier gas MFC and sample tube.
3. Connect a flow meter to the exhaust and measure the actual flow rate. If using a bubble burette, observe a bubble as it rises through the glass tube. The lines on the glass tube indicate the beginning and ending points for measuring the progress of a bubble through the tube. Use a stopwatch to measure the amount of time that elapses from the moment the bubble passes the lower mark on the tube until the moment it passes the higher mark on the tube.
4. Go to **Unit [n] > Gas Flow Calibration**.
5. Select the gas being flowed.

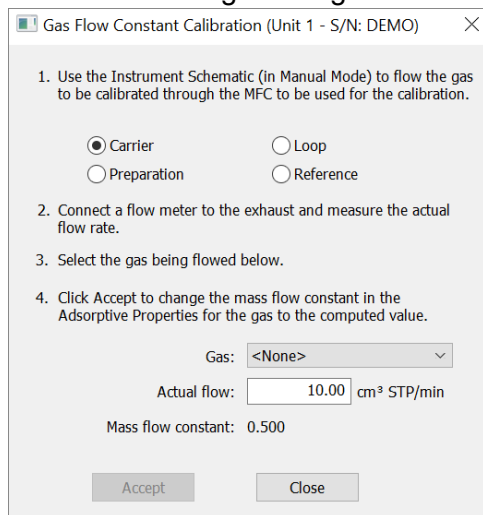

Gas Flow Constant Calibration (Unit 1 - S/N: DEMO)

1. Use the Instrument Schematic (in Manual Mode) to flow the gas to be calibrated through the MFC to be used for the calibration.

Carrier Loop
 Preparation Reference

2. Connect a flow meter to the exhaust and measure the actual flow rate.
3. Select the gas being flowed below.
4. Click Accept to change the mass flow constant in the Adsorptive Properties for the gas to the computed value.

Gas: <None>

Actual flow: 10.00 cm³ STP/min

Mass flow constant: 0.500

Accept Close

6. In *Actual flow* field, enter the actual flow rate to compute the mass flow constant.
7. Click **Accept** to change the *Mass flow constant* field in the *Adsorptive Properties* for the gas to the computed value.

SAMPLE THERMOCOUPLE



The equipment images in this topic may differ slightly from your equipment; however, the instructions are the same unless otherwise noted.

THERMOCOUPLE POSITION

[Use the Thermocouple Clamp on page 9 - 21](#)

The thermocouple must be attached to the analyzer prior to running an analysis. There are three possible configurations for the thermocouple:

- inside the sample tube
- inside the sample tube surrounded by a quartz sheath
- outside the sample tube

Best accuracy is obtained when the bare thermocouple is placed inside the sample tube. In some cases, one or more of the gases used during the experiment may react with the thermocouple's Inconel material. A quartz sheath is provided to protect the thermocouple when the gases or sample used in the experiment may damage it. In this case, the sheath is placed around the thermocouple and the thermocouple is positioned inside the sample tube. When placed inside the tube, the thermocouple can be adjusted so that the end is in the sample or just above it. Always try to position the end of the thermocouple as close to the furnace thermocouple as possible.

Positioning the thermocouple along the exterior of the sample tube is less accurate than the other configurations. If the thermocouple is placed outside the sample tube, ensure it is clamped against the sample tube, and that the end does not extend below the point where the sample tube begins to taper.

1. Power OFF the analyzer, then disconnect the analyzer from the power source.
2. Press in on the right side of the retractable handle on the top of the analyzer to protrude the handle. Use the handle to open the hinged top panel.



3. Pull down the upper front panel.



4. The valve cover is held in place by two knobs or plungers. Remove the valve cover by pulling the plungers outward until the valve cover is released. Pull the cover up and out.

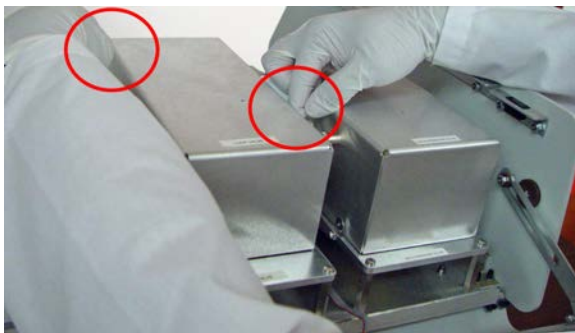

5. Remove the insulation that surrounds the valve. The thermocouple ports are located toward the front of the block.



The sample thermocouple and nearby components may be hot. Allow the sample thermocouple to cool before removing. Use the cotton gloves provided with the analyzer to protect your hands. If the zone is not near room temperature, loosening or tightening the fittings may damage the analyzer components.

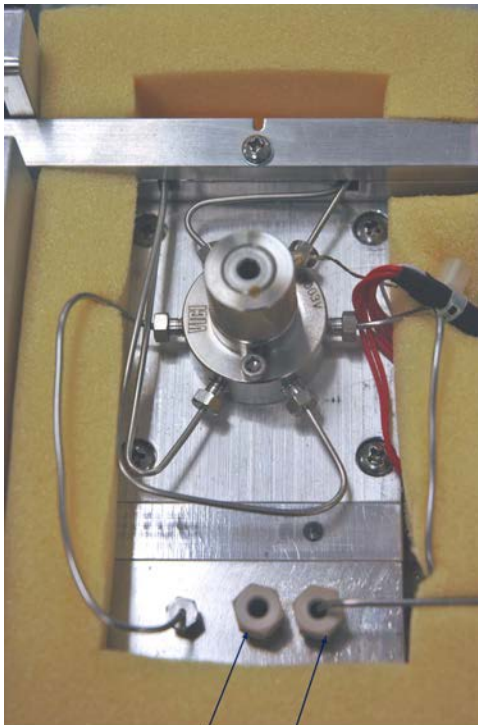

- A. Left port
- B. Right port

- Use the left port to place the thermocouple outside the tube.
- Use the right port to place the thermocouple inside the tube

6. Disconnect the thermocouple connector.
7. Use an open-ended wrench to loosen the sample thermocouple fitting.



The sheath is very fragile and can be easily broken. Because the sheath is made of quartz, cotton gloves must be worn when handling the sheath. Oils from fingers may lower the quartz melting point.

8. Adjust the thermocouple:

| | |
|---------------------------------------|--|
| <p>To change the position:</p> | <ol style="list-style-type: none"> a. Loosen the fitting for the stainless steel plug in the alternate thermocouple opening and remove the plug. b. Remove the fitting that retains the sample thermocouple. c. Move the sample thermocouple from its current position to the new position. d. Place the stainless steel plug in the unused thermocouple opening and tighten the fitting. Reinstall the sample thermocouple retaining screw. <p>If using the quartz sheath, perform the following before proceeding. The sheath can only be used when the thermocouple is being placed inside the sample tube.</p> <ol style="list-style-type: none"> i. Remove the ferrule from the thermocouple, straighten the thermocouple as much as possible. ii. Insert the thermocouple into the sheath. iii. Place a larger ferrule around the sheath. |
| <p>To adjust the length:</p> | <p>See Determine the length of the thermocouple on the next page. Adjust the thermocouple wire up or down as needed.</p> |

9. Tighten the thermocouple fitting.
10. Place the insulation in its original position. Reinstall the valve cover.
11. Return the upper front panel and the top panel to their original closed positions.
12. Power ON the analyzer.

DETERMINE THE LENGTH OF THE THERMOCOUPLE

When adjusting the length of the exposed portion, consider the following:

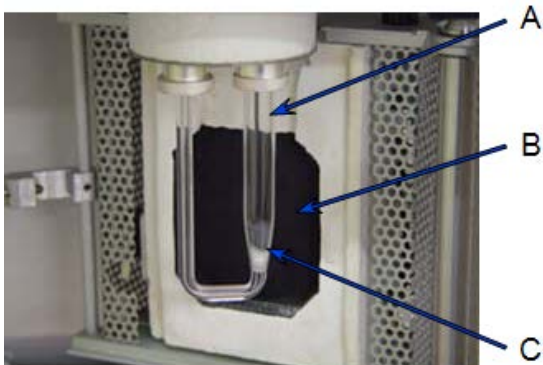

- A. Thermocouple
- B. Recessed area inside furnace
- C. End of thermocouple should be 2 to 3 mm (1/8 in.) above the sample

- The end of the thermocouple should be aligned as closely as possible with the furnace thermocouple.
- The end of the thermocouple should never be placed outside the painted (black), recessed area inside the furnace.
- If the thermocouple is positioned inside the tube, its end should generally be located approximately 2 to 3 mm (1/8 in.) above the sample surface. In some cases, allow the thermocouple to extend into the sample.
- If the thermocouple is positioned outside the tube, its end should not extend below the point where the sample tube begins to taper.

METAL TUBES

When using metal tubes, it may be helpful to use the dipstick included with the analyzer accessories to determine the appropriate length of the sample thermocouple. At times, a small amount of sample may adhere to the dipstick. When using very small amounts of sample for an analysis, the amount that adheres to the dipstick may affect analysis results.

1. After inserting the quartz wool and sample into the sample tube, insert the dipstick into tube.

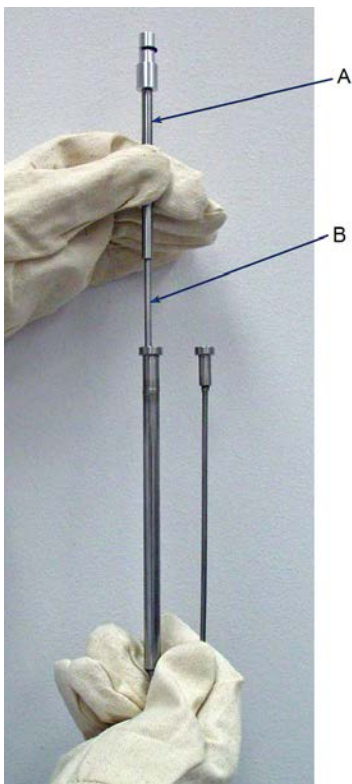

- A. Dipstick sleeve
- B. Dipstick rod

Dipstick shown inverted in second image

2. When the dipstick reaches the sample, gently press down on the sleeve until it is flush with the top of the sample tube.
3. Remove and invert the dipstick.



The exposed rod indicates the approximate length for the external portion of the thermocouple

- Place the inverted dipstick on the underside of the analysis port close to the thermocouple. Place it on a flat surface and not into one of the openings in the port.

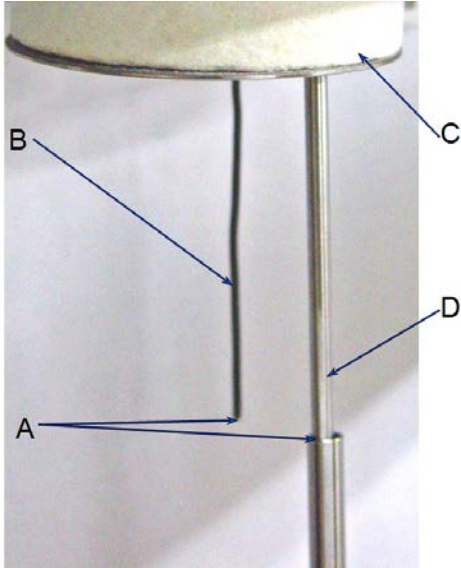

- A. Distance between the thermocouple and dipstick should be 2-3 mm (1/8 in.)
- B. Thermocouple
- C. Port
- D. Exposed rod of dipstick

The end of the thermocouple should be 2 to 3 mm (1/8 in.) above the exposed rod. If it is not, adjust the thermocouple length as needed.

USE THE THERMOCOUPLE CLAMP

If the thermocouple is placed outside the sample tube, a clamp must be used to secure the thermocouple to the sample tube.

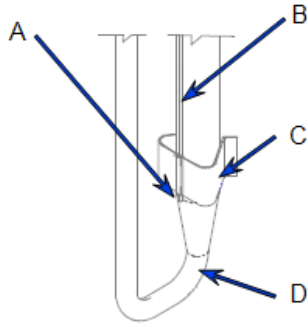

- A. Do not allow the thermocouple to extend below the point where the sample begins to taper
- B. Thermocouple
- C. Clamp
- D. Sample tube

RECALIBRATE THE SAMPLE THERMOCOUPLE

[Calibration on page 8 - 1](#)

A calibration file is created specifically for each analyzer before the analyzer is shipped. This calibration file is installed during installation. If the original calibration file is corrupted or missing, or if the sample thermocouple is replaced, recalibration will be needed.



Do not attempt to calibrate anything other than the sample thermocouple without prior approval from a qualified Micromeritics Service Representative.

Prior to recalibration, ensure:

- The analyzer is powered ON and the application is running.
- All heat zones to be calibrated are stabilized at ambient temperature.
- Familiarity with manually controlling the analyzer.
- All gas flows through the analyzer are stopped.
- The furnace is open, and the sample tube is removed (the thermocouple is bare and exposed).
- A traceable thermocouple meter and a water bath (ambient temperature) to immerse the sample thermocouple are available.

1. Go to **Unit [n] > Instrument Calibration**.

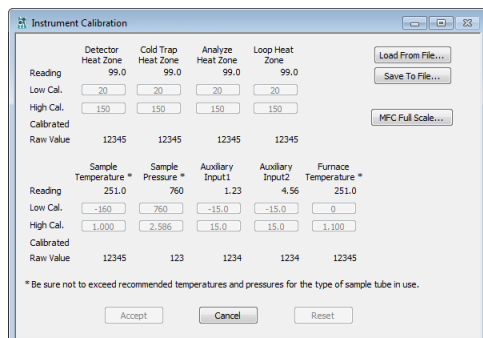

2. Place the water bath around the thermocouple so that the lowest 25 mm (1 in.) is immersed in the water. Place the thermocouple meter (reference thermocouple) parallel to the sample thermocouple so that both thermocouples are at the same temperature.
3. After the reference thermocouple meter reading stabilizes, enter the ambient temperature reading in the *Low Cal.* field on the *Instrument Calibration* window.
4. Remove the water bath. Move the tip of the reference thermocouple so that it touches the sample thermocouple tip yet allows the furnace to be closed.
5. Go to **Unit [n] > Enable Manual Control**. Ensure a checkmark displays to the left of the menu item. If the analyzer schematic does not display, go to **Unit [n] > Show Instrument Schematic**. Set the furnace target temperature to 1000 °C. Use a ramp rate of 50 °C/min.

Observe the schematic to ensure that both the furnace temperature and sample temperature are increasing.

6. After the furnace and sample temperature have stabilized, enter the reading from the reference thermocouple in the *High Cal.* field on the *Instrument Calibration* window.
7. Use manual control of the furnace to return the temperature to ambient.
8. On the *Instrument Calibration* window, click **Accept** to save the new values. Make a backup copy of the settings when prompted.

SAMPLE TUBE



The equipment images in this topic may differ slightly from your equipment; however, the instructions are the same unless otherwise noted.

SAMPLE TUBE INSTALLATION

[Sample Thermocouple on page 9 - 14](#)



Ensure the furnace has cooled to ambient temperature before installing tubes. Use the cotton gloves provided in the accessory kit when handling heated surfaces. These cotton gloves are not intended to protect hands when heated surfaces are above 60 °C. Rubber gloves may be used to handle the sample tube when it has cooled.



Wear latex gloves when handling the quartz sample tube. The natural oils in human skin can chemically damage and weaken the quartz tube. It is also important that the sample tube and its components, as well as the sample and exhaust ports, be clean and free of debris. Dust particles from quartz wool or the insulator disc of previous analyses may adhere to the port and/or components, preventing a proper seal of the sample tube.



Use only Kalrez (or equivalent) O-rings. Kalrez is rated for both chemical and temperature suitability in this application. O-rings of other materials could burn, melt, or decompose.



A. Sample tube collar
B. O-rings

1. Open the furnace.
2. Remove any sample tube stoppers immediately before connecting the sample tube to the analyzer.



For quartz tubes, do not allow the nuts to slide down rapidly to the curved portion of the tube. This could damage the tube.

3. Place an O-ring around each opening of the sample tube.
4. Insert the open ends of the sample tube into the openings under the upper panel, aligning the thermocouple in the proper position.
5. Push the sample tube up into the sample port until it comes to a stop. Tighten the fittings by turning the retaining nuts until finger tight.



Do not overtighten the analysis port fittings — doing so may break the quartz sample tube. The O-rings are sealed when the fittings are finger tight.

6. If the thermocouple is placed on the outside of the sample tube, clamp it to the tube.
7. Close and latch the furnace. The furnace will not heat unless closed. The pressure controller will also be disabled when the furnace is open.

SAMPLE TUBE REMOVAL



The furnace and sample tube may remain very hot for some time after analysis has ended. The sample tube retaining nuts are extremely hot, approximately 110 °C. Use extreme caution!

It is recommended to allow the furnace and sample tube to return to ambient temperature before touching them. If the sample tube has cooled, use rubber gloves when removing it. If it is still hot, use the cotton gloves provided.

1. Unlatch and open the furnace.



Support the sample tube retaining nuts so that they do not fall rapidly out of the analyzer. This may damage the sample tube.

2. Inspect the O-rings for cracks or other damage that might cause leaks. If the O-rings are cracked or damaged, replace them before reinstalling the sample tube. Additional O-rings are shipped with the analyzer. Otherwise, clean, dry, and re-install the O-rings.

SAMPLE TUBE FILTER OR O-RING REPLACEMENT

A frit filter is used to protect the analyzer internal components from contaminants that may be forced out of the sample tube during an analysis. As the analyzer is used, the filter may gradually become clogged with trapped particles. If the filter does become blocked, it must be removed and cleaned or replaced. One indication of a clogged filter is a sample pressure greatly exceeding atmospheric pressure. The nominal sample pressure reading should be a few mmHg above atmospheric pressure

1. Loosen the analysis port fittings while holding the sample tube.



The sample tube and nearby components may be hot. Allow the sample tube to cool before removing it. Use the cotton gloves provided in the accessory kit when handling heated surfaces. These cotton gloves are not intended to protect hands when heated surfaces are above 60 °C.

2. Carefully remove the sample tube by unscrewing the retaining nuts. Do not allow the nuts to slide down onto the curved portion of the sample tube or the tube may break.
3. Remove the left (smaller) sample tube fitting (it has a tube within a tube).
4. Use a small diameter probe to remove the O-ring and frit filter disk from the sample tube fitting.
5. Install a new (or cleaned) analysis port filter in the sample tube fitting.
6. Inspect the O-ring for cracks or cuts. If the O-ring is damaged, replace it with a new O-ring. Otherwise, clean the O-ring, dry it, and place it in the sample tube fitting. Ensure the O-ring is securely in place.
7. Place the left sample tube fitting back into position and tighten it slightly.
8. Reinstall the right sample tube fitting and sample tube, then tighten both fittings.

SEPTUM

The septum is used to inject quantities of gas into the analyzer.



Septum port



Do not use the septum at pressures above ambient. Gas may escape at elevated pressures.

Accuracy of data is diminished when poor techniques are used for injecting gas through the septum.

Injecting the gas through the septum causes a peak to appear, but it also causes a perturbation in the flow of gas through the analyzer. This perturbation is visible in the peak data. To minimize this perturbation, inject the gas more slowly into the septum. Prolonging the injection causes the peak to spread.

An injection method should be developed to balance the need to minimize the perturbation with the need for sharper peaks. See [Peak Editor on page 6 - 3](#) to adjust peak data to reduce the effects of perturbation.

- Always hold the syringe by its metal parts away from the needle. Holding the syringe by the glass allows body heat to affect the volume of gas in the syringe.
- After filling the syringe, allow the syringe to lie on a room temperature surface for about a minute. This ensures that the syringe and its contents are at room temperature.
- If the gas used is lighter than air, do not allow the filled syringe to remain in a vertical position (needle up) — the gas will diffuse out and the total volume will be reduced.

Fill the syringe

1. Empty the syringe completely.
2. Insert the syringe into a septum accessory installed on the gas regulator.
3. Draw the syringe plunger back until the syringe is completely filled with gas.
4. Remove the syringe from the septum and allow it to return to room temperature as described previously.
5. Press the plunger into the syringe until the correct amount of gas is contained in the syringe.

Alternate method to fill the syringe with nitrogen (evaporating from liquid nitrogen)

1. Empty the syringe.
2. Hold the tip of the needle just above the surface the liquid nitrogen.
3. Draw the syringe plunger back until the syringe is filled with nitrogen gas.
4. Allow the syringe to stabilize at room temperature.
5. Push the plunger into the syringe until the correct amount of gas is contained in the syringe.

Inject gas into the analyzer

1. Insert the needle fully into the septum.
2. Press the plunger into the syringe completely to ensure that the entire quantity of gas is injected from the syringe.
3. Remove the syringe.
4. Replace the septum cap and tighten finger tight.

SEPTUM REPLACEMENT

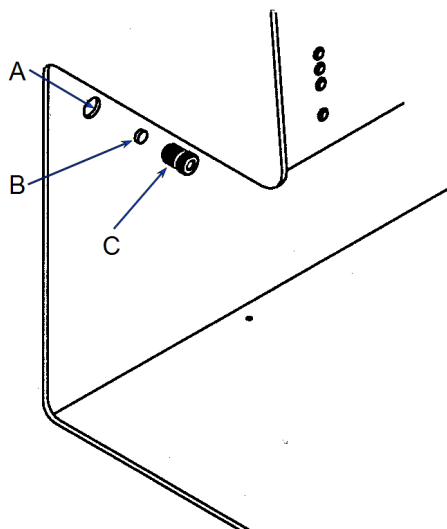

- A. Septum connector
- B. Septum
- C. Knurled nut

The septum usually requires replacing after approximately 100 injections when using the 1 mL syringe.

1. Turn the knurled nut counter-clockwise and remove it from the injection port.
2. Tap the nut into the palm of your hand to remove the septum and discard the used septum.
3. If the washer came out when the septum was removed, place the washer back into the knurled nut first.
4. Place a new septum into the knurled nut.
5. Place the knurled nut back onto the injection port. Turn the nut clockwise to finger tighten.



Do not use a wrench to tighten the septum retaining nut. Do not overtighten the retaining nut. Doing so may damage the septum or the fitting.

VAPOR GENERATOR INSTALLATION



Use caution in the areas where this symbol is displayed on the instrument. Use the cotton gloves provided in the accessory kit when handling heated surfaces. These cotton gloves are not intended to protect hands when heated surfaces are above 60 °C.



Topics in this section are applicable only if the vapor generator option is installed on the analyzer

[Vapor Generator Gas Path Leak Test on page 10 - 21](#)



Clean the vapor generator before changing to a different liquid.

The majority of the vapor generator's components are internal to the analyzer and are installed and calibrated by a Micromeritics Service Representative.



Use appropriate safety measures to prevent injury from contact with hazardous liquids used in the vapor generator.

1. Fill the Erlenmeyer flask to a depth of at least 50 mm (2 in.).
2. Unzip the heating mantle, place it around the flask; do not zip it closed. Screw the flask into the port on the underside of the front panel. The metal cylinder that extends down from the vapor generator port is the aerator. When the flask is properly installed, the aerator should extend down into the flask and its contents. Zip the mantle closed.
3. Plug the heating mantle connector into the appropriate connector on the recessed front panel.
4. Twist the ring to secure the connector.
5. The valve that controls the flow of gas from the vapor generator has two states: *Bypass* and *Vapor*. In the sample file, select *Vapor* for the state of the vapor generator valve during the portion(s) of analyses to flow vapor through the system. The loop gas is the gas that flows through the vapor generator; ensure the gas used for vapor generation is connected to one of the loop gas inlet valves.

CLEAN THE VAPOR GENERATOR

[*Enable Manual Control on page 10 - 4*](#)

It is necessary to clean the vapor generator before changing the liquid.

1. Fill the flask with Isopropyl Alcohol (IPA).
2. Install the flask on the analyzer.
3. Flow an inert gas through the vapor generator and analyzer for approximately 20 minutes. Such cleaning can be performed using Manual Control.

10 TROUBLESHOOTING

The analyzer has been designed to provide efficient and continuous service; however, certain maintenance procedures should be followed to obtain the best results over the longest period of time. When unexpected results occur, some common operational problems not indicated on the window and their respective causes and solutions are provided.

The following can be found on the Micromeritics web page (www.micromeritics.com).

- CryoCooler II and CryoCooler III Operator Manual (PDF)
- Error Messages document (PDF)
- Parts and Accessories

Most operational problems are caused by:

- Leaks (commonly found at the sample tube O-ring at the analysis port)
- Sample weighing errors
- Use of too much analysis bath fluid in the Dewar at the start of an analysis
- Entry of incorrect system volume for analysis
- Impure gas supply

When unexpected analysis results occur, check the above first. Some common operational problems not indicated on the window and their respective causes and solutions are provided below:

Does not work when powered ON

Cause A: Power cord is not fully inserted at one of the ends

Action A: Insert power plug firmly into outlet socket. Insert unit connector into power connector opening.

Cause B: No power at outlet.

Action B: Plug in another electrical device to test outlet. If there is no power, contact electrician.

Cause C: Plug prongs are bent so that contact is not made at outlet.

Action C: Gently move power plug at the outlet while watching the status LEDs on the analyzer front panel. If at least one LED becomes illuminated, have an electrician replace the outlet or the plug.

Cause D: Power cord is damaged.

Action D: Have an electrician check cord using a test meter. Replace cord if defective.

Cause E: Loose internal connection or broken wire.

Action E: Call a Micromeritics Service Representative for repair or replacement.

Liquid nitrogen boils away too quickly to complete an analysis.

Cause A: Dewar damaged.

Action A: Replace Dewar.

Cause B: Lengthy analysis.

Action B: Refill Dewar during analysis.

Specified temperature not reached or not maintained.

Cause: Thermocouple or another internal component is damaged or disconnected.

Action: Contact the appropriate service personnel.

Gas drained from gas cylinder.

Cause: Leaks in the gas line connection.

Action: Replace the gas cylinder; then pressurize the system. Close, then open the cylinder valve. If the needle on the pressure gauge on the gas cylinder jumps abruptly, a leak in the gas line connection may be indicated. Check all gas line connections.

Too much heat supplied to analyzer.

Cause: Thermocouple or another internal component is damaged or disconnected.

Action: Contact the appropriate service personnel.

A stable TCD baseline cannot be maintained.

Cause A: TCD filaments are contaminated or need to be replaced.

Action A: See [TCD Assembly on page 10 - 30](#) to replace or clean the TCD.

Cause B: Possible leak in reference/carrier path.

Action B: Perform leak test in the reference/carrier path. See [Perform a Leak Test on page 10 - 18](#).

Cause C: Faulty RTD in one of the temperature zones.

Action C: Access manual mode and check for temperature stability in the temperature zones.

Data collection results in very high or very low peaks that are inconsistent with previous experience.

Cause A: TCD filaments are contaminated or need to be replaced.

Action A: See [TCD Assembly on page 10 - 30](#) to replace or clean the TCD.

Cause B: A different (lower) TCD temperature is being used.

Action B: Repeat the analysis using a higher temperature.

During data collection, a TCD signal of zero is recorded, or no peaks are seen.

Cause A: TCD filaments are contaminated or need to be replaced.

Action A: See [TCD Assembly on page 10 - 30](#) to replace or clean the TCD.

Cause B: TCD temperature was not reset after a run automatically suspended.

Action B: Ensure the TCD is re-enabled after all run suspensions.

Furnace will not heat.

Cause A: Furnace not closed and latched.

Action A: Close and latch the furnace.

Cause B: The furnace is not plugged in.

Action B: Plug in the furnace connector.

Cause C: Thermocouple damaged or not plugged in.

Action C: If unplugged, plug in the thermocouple. Replace the thermocouple if necessary.

Pressure will not rise or readings very unstable.

Cause A: Furnace not closed and latched.

Action A: Close and latch the furnace.

Cause B: The furnace is not plugged in.

Action B: Plug in the furnace connector.

ENABLE MANUAL CONTROL

Unit [n] > Enable Manual Control

[Show Instrument Schematic on page 2 - 16](#)

Use *Enable Manual Control* to enable the manual control of certain system valves and pump components on the analyzer schematic. When this option is enabled, a checkmark appears to the left of ***Unit [n] > Enable Manual Control***. If the analyzer schematic is not immediately visible, go to ***Unit [n] > Show Instrument Schematic***.

FOAM AIR FILTER REPLACEMENT

The foam air filter should be cleaned every 30 days (more frequently in environments with high levels of dust). If, after cleaning, it is determined that the filter is degrading, it should be replaced.



The equipment images in this topic may differ slightly from your equipment; however, the instructions are the same unless otherwise noted.

1. Go to **Unit [n] > Enable Manual Control**. Ensure a checkmark displays to the left of the menu item. If the analyzer schematic does not display, go to **Unit [n] > Show Instrument Schematic**.
2. Right-click the analysis valve and ensure that it is in the *Prepare* position.
3. Remove the furnace, the cold trap (or delay path), the sample tube, and any other parts or accessories from the front of the analyzer.
4. Remove the black mat from the lower panel.



5. Remove the screws that hold the stainless steel support plate in place.



6. Hold the furnace support post and lift the support plate up and away from the analyzer.



7. Pull the foam air filter up and out of the analyzer.



8. Rinse the foam air filter with clean water and allow it to dry completely.
9. If the filter is in good condition, place it back inside the analyzer. If the filter needs to be replaced, obtain a new filter and place it inside the analyzer.
10. Place the support plate back into position and reinstall its retaining screws.
11. Reinstall the furnace, cold trap (or delay path), sample tube, etc.

GUIDELINES FOR CONNECTING GASES

Regulator Pressure Settings

| Analyzer | Gauge should indicate |
|----------|------------------------------|
| AutoChem | 14 - 16 psig (95 - 110 kPag) |



Exceeding the maximum recommended pressure could cause personal injury or damage the instrument.



These instructions refer to the installation of a gas line, regulator, and gas cylinder for each type of gas used. If expansion kits or other accessories are used in the lab, special consideration should be given to these configurations when installing the gas lines.



Improper handling, disposing of, or transporting potentially hazardous materials can cause serious bodily harm or damage to the instrument. Always refer to the SDS when handling hazardous materials. Safe operation and handling of the instrument, supplies, and accessories are the responsibility of the operator.

- Place gas cylinders within 6 feet (2 m) of the gas inlets of the analyzer. Place the cylinders close enough to allow for proper connection at the analyzer inlet.

Using gas line extenders on gas cylinders located in remote areas may degrade gas quality and reduce pressure.

Long gas lines, such as those used with gas cylinders placed in remote areas, must be purged for an extended period of time to remove ambient gases. When possible, avoid placing gas cylinders in remote locations. It is always best to have gas cylinders located near the analyzer.

- Use a retaining strap (or other appropriate tether) to secure the gas cylinder.
- Always use the gas lines provided with the analyzer. It is very important that proper gas lines are used with the analyzer.
 - **Do not use** polymer tubing for the gas line.
 - **Do not use** flexible gas lines. Some flexible lines may appear to be appropriate, such as those with a herringbone covering, but the line may be coated internally with a polymer.
- Carefully route the gas lines from the cylinder to the analyzer avoiding overlapping or entangling gas lines. This will help avoid confusion when maintenance is required.
- Label the gas line at the analyzer inlet for proper identification and maintenance.

- Replace gas cylinders before gas is depleted. It is best to replace a gas cylinder when the pressure reads approximately 600 psi or 4100 kPa on the high-pressure gauge. Contaminants adsorbed to the walls of the cylinder will desorb as the pressure decreases.

REPLACE A GAS CYLINDER

Regulator Pressure Settings

| Analyzer | Gauge should indicate |
|----------|------------------------------|
| AutoChem | 14 - 16 psig (95 - 110 kPag) |



Exceeding the maximum recommended pressure could cause personal injury or damage the instrument.



These instructions apply to working with inert gases only. When working with hazardous gases, follow the safety procedures established by your lab.

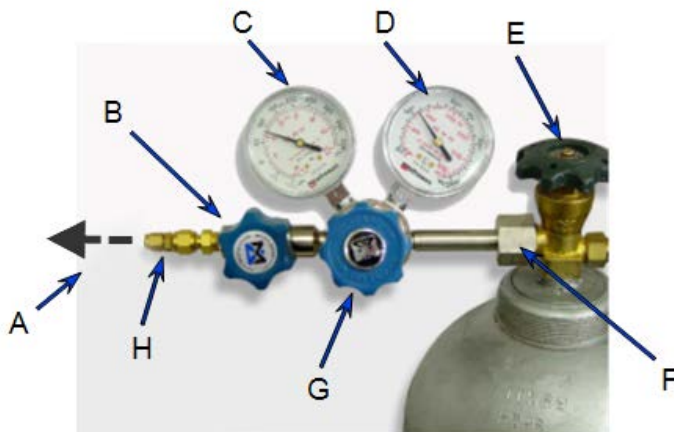

- A. Gas tubing to instrument
- B. Gas regulator shut-off valve
- C. Low pressure gauge
- D. High pressure gauge
- E. Gas cylinder shut-off valve
- F. Regulator connector nut
- G. Regulator control knob
- H. Brass reducer fitting

Disconnect a Depleted Gas Cylinder

1. Close the regulator shut-off valve and gas cylinder shut-off valve by turning the knobs clockwise.
2. Disconnect the gas line from the regulator. Gas will be vented from the line. It is not necessary to disconnect the gas line from the analyzer inlet if the cylinder will be replaced immediately with one of the same type.
3. Open the gas regulator shut-off valve by turning the knob counter-clockwise. Gas will be vented from the regulator.
4. Turn the regulator control knob clockwise to open and vent any remaining gas. Both gauges should read at or near zero. If not, make sure the gas regulator shut-off valve is open.
5. Close the regulator by turning the control knob counter-clockwise.
6. Use an appropriate wrench to loosen the nut at the regulator connector nut then remove the regulator from the cylinder.
7. Replace the protective cap on the depleted cylinder. Disconnect the retaining strap and move the cylinder to an appropriate location.

Connect a Gas Cylinder

1. Use an appropriate cylinder wrench to remove the protective cap from the replacement gas cylinder.
2. Place the protective cap in a secure location. It will be needed to recap the gas cylinder when it is depleted and replaced.
3. Attach the gas regulator to the gas cylinder connector. Hand tighten the nut, then use an appropriate wrench to tighten an additional 3/4 turn.



Over-tightening the fitting may cause a leak.

4. Check for leaks at the high pressure side of the regulator and in the connector.
 - a. Turn the regulator control knob fully counter-clockwise.
 - b. Slowly open the gas cylinder shut-off valve, then quickly close it.
 - c. Observe the pressure on the high pressure gauge for approximately one minute.
 - If the pressure is stable, proceed with the next step.
 - If the pressure decreases, tighten the regulator connector nut until it becomes stable. If the pressure does not remain stable, remove the regulator and clean all contacts at the regulator connection, then reinstall the regulator.
5. Purge the air from the lines by doing the following:



Purge the regulator before starting to prevent contamination of the analysis gas supply.

- a. Open the gas cylinder valve to pressurize the regulator, then close the valve.
- b. Adjust the *Pressure Control* knob to approximately 5 psi.
- c. Turn the regulator *Shut-off* valve counter-clockwise to open. Allow gas to flow until both gauges read approximately zero.
- d. Close the regulator *Shut-off* valve to stop gas flow.
- e. Reconnect the gas line to the regulator.
- f. Use two 7/16 in. (11 mm) wrenches to tighten the gas line connection. Hold one wrench fitting steady and the other to tighten the connector nut.

6. Set the analyzer pressure by doing the following:
 - a. Turn the *Regulator Control* knob clockwise until the low pressure gauge indicates the appropriate pressure. See the *Regulator Pressure Settings* table in *Connect a Gas Cylinder*.
 - b. Open the regulator *Shut-off* valve.
 - c. Open the gas cylinder *Shut-off* valve and flow gas for 10 to 30 seconds.
 - d. Close the gas cylinder *Shut-off* valve.
 - e. Close the gas cylinder valve.
7. If the gas line to the instrument inlet was previously disconnected, reconnect it now.

O-RING COMPATIBILITY

O-ring selection for chemisorption measurements is based on temperature, time, and chemical compatibility. Chemical compatibility should be the first consideration when selecting an appropriate O-ring. The time at which the furnace, and subsequently the sample cell, is at elevated temperature can also affect the performance of the O-rings and should be a secondary consideration. Common O-ring materials include Buna-N (nitrile), Viton (fluoroelastomer), and Kalrez (perfluoroelastomer). Kalrez has historically been used extensively for chemisorption measurements due to compatibility with a wide range of chemicals and temperatures and should be suitable for all applications of the chemisorption option. Viton or Buna-N may also be suitable for analyses similar to the reference material example file. The ability to re-use Buna-N or Viton O-rings may be limited, while the re-use of Kalrez O-rings should be broader. Frequency of use and, potentially, several other factors affect the duration of O-ring use, so rigid rules cannot be specified for these materials. Leak rate and ultimate vacuum levels may be used as indicators for O-ring performance.

PREVENTIVE MAINTENANCE

Perform the following preventive maintenance procedures to keep the analyzer operating at peak performance. Micromeritics also recommends that preventive maintenance procedures and calibration be performed by a Micromeritics Service Representative every 12 months.

| Procedure | 3 months or 75 runs | 6 months or 150 runs | 9 months or 225 runs | 12 months or 300 runs |
|---------------------------------------|------------------------|-------------------------|-------------------------|--------------------------|
| Change septum | | U-R | | F |
| Change Injection loop | | U-I-A | | F |
| Foam air filter | | | | F |
| Sample tube filter | | U-R | | F-R |
| Clean analyzer exterior | | U-I-A | | F |
| Adjust sample thermocouple | | U-I-A | | F |
| Clean the cold trap | U-I-A | U-I-A | U-I-A | F |
| Replace TCD | | U-I-A | | F |
| Clean Dewar | U-I-A | U-I-A | U-I-A | F |
| Change sample O-rings | | | | F-R |
| Perform leak check | | U-I-A | | F |
| Check temperature stability | | | | F |
| Check sample thermocouple calibration | | | | F-A |
| Perform calibration run | | | | F |

Legend:

- U** User performed
- F** Factory / Micromeritics Service procedure
- I** Inspect
- R** Replace
- A** As necessary

CHECK AND CLEAN THE DEWAR



When handling Dewars, follow the precautions outlined in [Dewar Precautions on page 5 - 3](#).



Always handle glass Dewars with care. Any product incorporating a vacuum is a potential safety hazard and should be treated with caution. If in doubt, contact your safety officer.

Ice and suspended frost particles may accumulate in the bottom of the analysis port Dewar. Particles or deposits exceeding 1/4 in. (6 mm) in depth may jam between the bottom of the sample tube and the bottom of the Dewar.

Accumulations of fine particles impede liquid nitrogen circulation around the bottom of the sample tube. This causes the sample temperature to be slightly higher which, in turn, can cause pore volume measurement errors in those samples exhibiting high isotherm slope above 0.97 relative pressure.

Accumulated ice is likely to melt and form a pool of water in the Dewar if all liquid nitrogen evaporates. The water must be removed, otherwise it will solidify when liquid nitrogen is added and could press on the bottom of the sample tube causing breakage.

To ensure problems do not develop due to ice accumulation, check the Dewar after each use. Clean on a weekly basis.

1. Remove the Dewar from the analyzer.
2. Pour out liquid nitrogen into an appropriate cryogenic container. Do not re-use liquid nitrogen.



Do not pour liquid nitrogen directly into a sink. Doing so may cause drain pipes to burst.

3. Rinse the Dewar with warm water to melt any remaining ice accumulation which may remain. Dry thoroughly.
4. Replace the Dewar.

CLEAN THE INSTRUMENT

The exterior casing of the instrument may be cleaned using a clean, lint-free cloth dampened with isopropyl alcohol (IPA), a mild detergent, or a 3% hydrogen peroxide solution. Do not use any type of abrasive cleaner. It is not necessary to remove knobs, screws, etc. while cleaning.



Do not allow liquid to penetrate the casing of the instrument. Doing so could result in damage to the unit.

POWER INSTRUMENT ON AND OFF



Do not connect or disconnect cables when the instrument is powered ON.

When the system is powered on for the first time or after a period of non-use, allow it to warm up for at least three hours before analyses. During this time, a purge carrier gas (such as helium or nitrogen) should be flowed through the system at about 50 cm³/min. The heat zones should be set at 110 °C.

When the instrument is powered on (but the application is still not running), the red Fault light and the green Attention! light are lit. When the application is started and communication is established with the instrument, these lights are turned off and the green OK light is lit.



A carrier gas must be flowing through the detector whenever the detector filaments are turned on; otherwise, the filaments will deteriorate and lose sensitivity. If the gases are shut off, the filaments are automatically turned off after five minutes.

Power ON the equipment in the following order:

1. Computer, monitor, and printer.
2. Analyzer.

Power OFF the equipment in the following order:

1. Exit the analysis program. Failure to do so could result in loss of data. If an analysis is in progress when closing the application, the following message is displayed:

2459 - An Instrument is busy. A delay in restarting this application could result in loss of new data. Continue program exit? Yes / No

Yes. Closes the program. The analysis continues and data continue to be collected. The data will be restored when the application is restarted. Reports queued in the print manager will print. If a power failure occurs and an uninterruptible power supply (UPS) is not attached to the analyzer, the data collected after exiting the analysis program are lost.

No. The program remains open, and the analysis continues to run.

2. Computer, monitor, and printer.
3. Analyzer

PERFORM A LEAK TEST

This tests all fitting connections in the gas flow path and part of the analysis valve. Any flow reading other than zero indicates a leak in the gas flow path being tested.

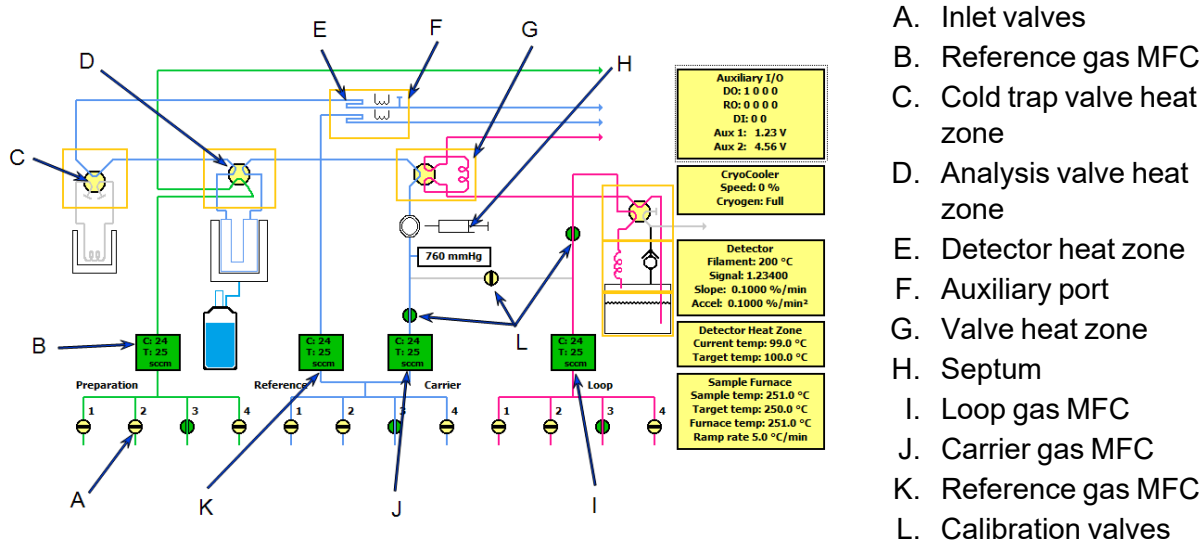

1. Go to **Unit [n] > Enable Manual Control**. Ensure a checkmark displays to the left of the menu item. If the analyzer schematic does not display, go to **Unit [n] > Show Instrument Schematic**.
2. Prepare for the leak test:
 - a. Set all heat zones to ambient temperature.
 - b. Set all four MFCs to 50 sccm.
 - c. Allow the analyzer to cool to room temperature.



This test must be performed in the order provided to ensure the analyzer is fully tested. Any flow reading other than zero indicates a leak in the gas flow path being tested.

PREPARATION GAS PATH LEAK TEST

1. Right-click the analysis valve and select *Analyze*.
2. Right-click the first preparation valve and select *Open*.
3. Plug the preparation gas exhaust outlet.
4. Observe the preparation gas MFC reading as it slowly drops to zero. A flow reading of zero indicates the flow path between the preparation gas MFC and the preparation exhaust does not leak.
5. To fix a leak that may be indicated on the preparation gas MFC, tighten the fittings in the gas flow path and observe the reading for any decrease that would indicate that the leak has stopped.



Any leak detected in the remaining steps of this procedure may be fixed by using the same process mentioned in Step 5.

6. Right-click the preparation gas MFC and select *Stop Flow*. This will close the helium valve.
7. Remove the plug from the preparation gas exhaust outlet.

REFERENCE GAS PATH LEAK TEST



Valve positions need not be preset for this test. Any flow reading other than zero indicates a leak in the gas flow path being tested.

1. Right-click the reference valves and select *Open*.
2. Plug the reference gas exhaust outlet.
3. Observe the reference gas MFC reading as it slowly drops to zero.
A flow reading of zero indicates the flow path between the reference gas MFC and the reference gas exhaust does not leak. This tests all fitting connections in the gas flow path and the reference side of the thermal conductivity detector.
4. Right-click the reference gas MFC and select *Stop Flow*. This will close the valve.
5. Remove the plug from the reference gas exhaust outlet plug.

CARRIER GAS PATH LEAK TEST

1. Right-click the cold trap valve and select *Bypass*.
2. Right-click the analysis valve and select *Prepare*.
3. Right-click the loop valve and select *Fill*.
4. Turn the pressure control knob on the helium gas regulator to deliver less than 50 psi (345 kPag).
5. Right-click the carrier gas inlet valves and select *Open*.
6. Plug the analysis gas exhaust outlet.
7. Right-click on calibration valve B and select *Close* , then repeat the step for calibration valve C.
8. Observe the carrier gas MFC reading as it slowly drops to zero. A flow reading of zero indicates the flow path between the carrier gas flow MFC and calibration valve B does not leak.
9. Right-click calibration valve B and select *Open* .
10. Observe the carrier gas MFC reading as it slowly drops to zero or remains at zero from the previous test. A flow reading of zero indicates the flow path between the carrier MFC and the carrier exhaust outlet does not leak. This tests all fitting connections in the gas flow path and part of the analysis valve, part of the bypass valve, the transducer, the septum, part of the inject valve, and the analysis side of the thermal conductivity detector.
11. Right-click the loop valve and select *Inject*.
12. Observe the carrier gas MFC reading as it slowly drops to zero or remains at zero from the previous test. A flow reading of zero indicates the flow path between the carrier gas MFC and the carrier gas exhaust outlet does not leak. This tests all fitting connections in the gas flow path, the remaining parts of the loop valve, and the loop.
13. Install an empty sample tube on the sample port.
14. Right-click the analysis valve and select *Analyze*.
15. Observe the carrier gas MFC reading as it slowly drops to zero or remains at zero from the previous test. A flow reading of zero indicates the flow path between the carrier gas MFC and the carrier gas exhaust outlet does not leak. This tests all fitting connections in the gas flow path, the sample tube, and the remaining parts of the analysis valve.
16. Install a cold trap (or a delay path) on the cold trap port.
17. Right-click the cold trap valve and select *Trap*.
18. Observe the carrier gas MFC reading as it slowly drops to zero or remains at zero from the previous test. A flow reading of zero indicates the flow path between the carrier gas MFC and the carrier gas exhaust outlet does not leak. This tests all fitting connections in the gas flow path, the remaining parts of the cold trap valve, and the cold trap.
19. Right-click the carrier valves and select *Close* to close the helium valve.
20. Remove the plug from the analysis exhaust outlet.
21. Reset the pressure on the helium gas regulator to its original pressure.

VAPOR GENERATOR GAS PATH LEAK TEST



This test is applicable only if the vapor generator option is installed on the analyzer.

1. Right-click the loop valve and select *Inject*.
2. Right-click the vapor valve and select *Bypass*.
3. Right-click calibration valve C and select *Close*.
4. Right-click calibration valve D and select *Close*.
5. Plug the loop gas exhaust outlet.
6. Plug the vapor generator gas exhaust outlet.
7. *Right-click the loop gas valves and select Open.*
8. Observe the loop gas MFC reading as it slowly drops to zero.

A flow reading of zero indicates the flow path between the loop gas MFC and calibration valves C and D does not leak. This tests all fitting connections in the small section of the gas flow path to calibration valves C and D.

9. Right-click calibration valve D and select *Open*.
10. Observe the loop gas MFC reading as it slowly drops to zero or remains at zero from the previous test.

A flow reading of zero indicates the flow path between the loop gas MFC and the loop gas exhaust outlet does not leak. This tests all fitting connections in the gas flow path, portions of the vapor generator valve, and the tubing up to the inject valve.

11. Install an empty flask onto the vapor generator port.
12. Right-click the vapor valve and select *Vapor*.
13. Observe the loop gas MFC reading as it slowly drops to zero or remains at zero from the previous test.

A flow reading of zero indicates the flow path between the loop gas MFC and the loop gas exhaust does not leak. This tests all fitting connections in the gas flow path, the remaining portions of the vapor generator valve, and the relief valve in the vapor generator.

14. Right-click the loop gas MFC and select *Stop Flow* to close the gas valve.
15. Remove all exhaust plugs.

LOOP GAS PATH LEAK TEST



This test is applicable only if the vapor generator option is installed on the analyzer.

1. Right-click the loop valve and select *Inject*.
2. Right-click calibration valve C and select *Close*.
3. Right-click calibration valve D and select *Close*.
4. Plug the loop gas exhaust outlet.
5. Right-click the loop gas valves and select *Open*.
6. Observe the loop gas MFC reading as it slowly drops to zero.

A flow reading of zero indicates the flow path between the loop gas MFC and calibration valves C and D does not leak. This tests all fitting connections in the small section of the gas flow path to Calibration Valves C and D.

7. Right-click calibration valve D and select *Open*.
8. Observe the loop gas MFC reading as it slowly drops to zero or remains at zero from the previous test.

A flow reading of zero indicates the flow path between the loop gas MFC and the loop gas exhaust outlet does not leak.

This tests all fitting connections in the gas flow path, calibration valves C and D, and the tubing to the loop valve.

PURGE THE SYSTEM

When changing the gas that is flowing through the analyzer, or when the type of gas connected to a port is changed, purge the analyzer of the previous gas by flowing the new gas. The system should also be purged if the loop is changed.

If changing gases during an analysis, allow the new gas to flow for a period of time before creating conditions that cause the experiment to begin (such as elevating the temperature). In some cases, purge one gas by flowing an inert gas for a period of time before starting to flow another gas. This may be useful for avoiding undesirable combinations of gases within the analyzer.

To flow an inert gas between incompatible gases, insert a *Change Gas Flows* step (in which an inert gas is flowed for a period of time) and a *Wait* step (to wait for the inert gas to purge the analyzer) between other steps that involve incompatible gases.



When gas flows are changed while the analyzer is recording data, the gas flow is briefly disturbed. This may result in a brief period of noise or other visible disturbances on the peak data. Either disregard the disturbance or insert a *Wait for stable baseline* step immediately after changing gas flows.



Purge one line at a time. It is the operator's responsibility to ensure that dangerous combinations of gases are not created while using Manual Control. It may be necessary to flow an inert gas through the system between flows of incompatible gases.

1. Go to **Unit [n] > Enable Manual Control**. Ensure a checkmark displays to the left of the menu item. If the analyzer schematic does not display, go to **Unit [n] > Show Instrument Schematic**.
2. Set the Cold Trap valve, Analysis valve, Loop valve, and Detector heat zone temperatures to 110 °C.
 - a. Move the cursor over each valve until the cursor changes to a thermometer.



When the cursor is on a heat zone, it appears as a thermometer. If it appears as a hand turning a valve, move the cursor slightly.

- b. Right-click and select Set temperature.
 - c. Enter 110.
 - d. Click **OK**.
3. Wait until the temperature reaches the 110 °C target. Click the heat zone to display both the target and current temperatures on the right side of the schematic.

-
4. Purge all air from the gas lines. These steps should be performed for each inlet valve for the preparation, carrier, and loop gas lines where a gas cylinder is connected.
 - a. Right-click the preparation gas Mass Flow Controller (MFC).
 - b. Select *Set Flow Rate* and enter *50*.
 - c. Click **OK**.
 - d. Right-click gas inlet valve 1 and select *Open*.
 - e. Allow the gas to flow for approximately 20 minutes or until the lines have been purged of air.
 - f. Repeat Step 4 for each valve that has a gas cylinder connected.

CHANGE THE GAS FLOW DURING AN ANALYSIS

When changing gases during an analysis, allow the new gas to flow for a period of time before creating conditions that cause the experiment to begin (such as elevating the temperature). Purge one gas (by flowing an inert gas for a period of time) before starting to flow another gas. This may be useful for avoiding undesirable combinations of gases within the analyzer.

To flow an inert gas between incompatible gases, insert a *Change Gas Flows* step (in which an inert gas is flowed for a period of time) and a *Wait step* (to wait for the inert gas to purge the analyzer) between other steps that involve incompatible gases.



When gas flows are changed while the analyzer is recording data, the gas flow is briefly disturbed. This may result in a brief period of noise or other visible disturbances on the peak data. Either disregard the disturbance or insert a *Wait for stable baseline* step immediately after changing gas flows.

RECOVER FROM A POWER FAILURE

The analyzer saves entered and collected data in case of power failure. File parameters and any other data entered will still be present when power is restored. If an analysis was in progress when the power failure occurred, it will be canceled when the analyzer restarts. Any data collected during the analysis will still be present, but the analysis should be restarted in order to produce complete results.

REPLACE THE INJECTION LOOP



The equipment images in this topic may differ slightly from your equipment; however, the instructions are the same unless otherwise noted.

1. Ensure that no heat is being applied to the analyzer. If necessary, enable manual control and set the target temperature for the heat zones to ambient. Wait for the analyzer to cool.
2. Press in on the right side of the retractable handle on the top of the analyzer to protrude the handle. Use the handle to open the hinged top panel. It is not necessary to remove the top panel. Pull down the upper front panel.



Depending upon the state of the analyzer, the internal components may be hot. Use caution.

3. The *Fill/Inject* (Loop) valve cover is held in place by two retaining plungers. Remove the valve cover by pulling the plungers outward until the *Fill/Inject* valve cover is released. Pull the cover up and out.

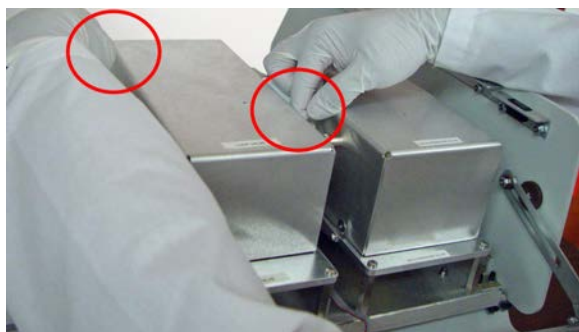

4. Remove the insulation from *Fill/Inject* valve.
5. Unscrew the loop nut and lay it aside. It may be necessary to loosen the screw in the middle of the assembly in order to free the loop nut.

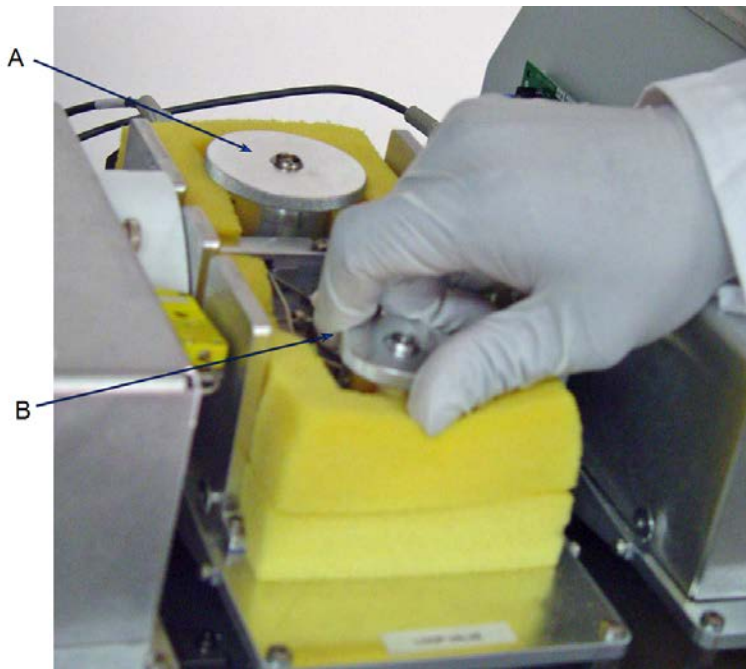

- A. The 5.0 cm³ loop is located in this position when installed
- B. The 0.5 cm³ and the 1.0 cm³ loops are located in this position when installed

6. Remove the enclosure ring.

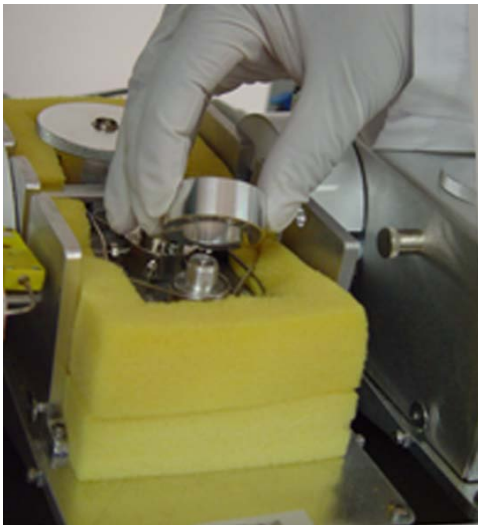

7. Use a 1/4 in. open-end wrench to loosen the nuts on the injection loop.

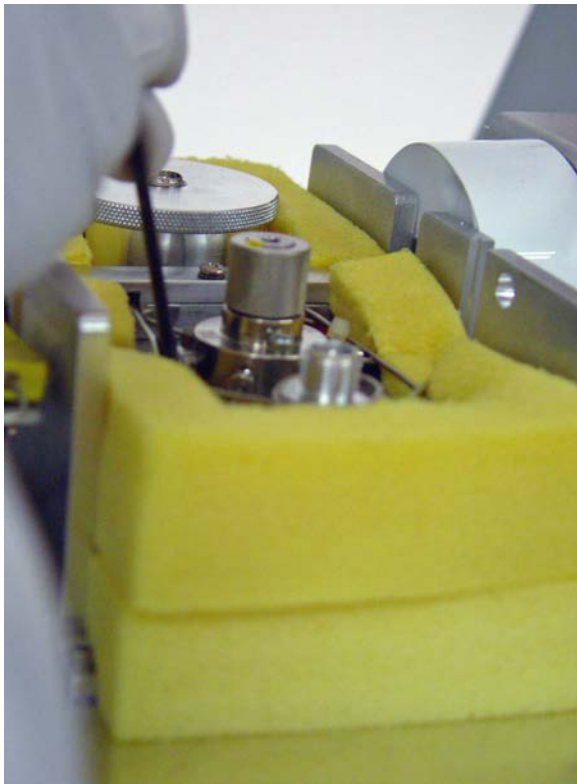

8. Pull up and remove the injection loop and enclosure ring from the mounting plate.

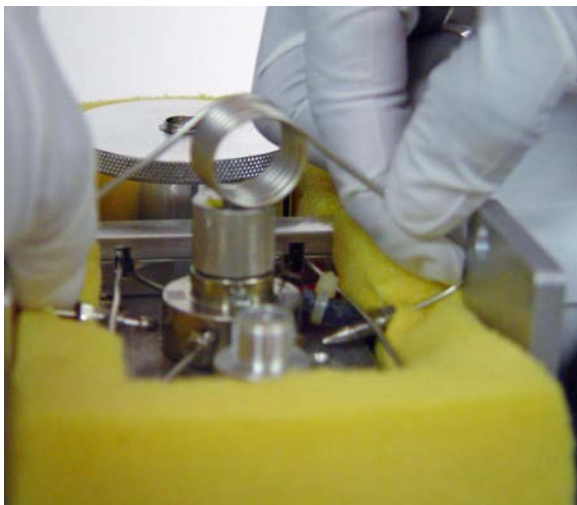

Ensure the body of the loop is positioned in the temperature-controlled enclosure of the loop valve. This orientation keeps the temperature (and volume) of the loop constant. Failure to keep the full loop at a constant temperature may cause variations in the quantity of gas contained in the loop.

9. Install the replacement injection loop by placing the ends of the loop into the sides of the valve and turning the nuts finger tight.
10. Push the replacement loop down to contact the mounting plate and place the loop enclosure ring firmly into place.
11. Screw the loop nut down finger tight. Tighten the screw in middle of the assembly if it was loosened earlier.
12. Tighten the loop nuts securely, using a 1/4 in. open-end wrench.
13. Check the injection loop for leaks. If a leak is detected, the injection loop is probably not installed properly. Repeat the installation and check for leaks again. See [Perform a Leak Test on page 10 - 18](#).
14. After checking for leaks, move the insulation back into position and reinstall the *Fill/Inject* valve cover.
15. Close the top panel and the lower front panel.
16. After installing a new injection loop, the loop must be calibrated. Go to **Unit [n] > Unit Configuration** to update the loop volume.



The smaller loops connect to the same openings in the valve, but rest in a different position than the larger loop.

TCD ASSEMBLY



The equipment images in this topic may differ slightly from your equipment; however, the instructions are the same unless otherwise noted.

The filaments in the thermal conductivity detector assembly are heated to high temperatures and may be exposed to corrosive gases, therefore they may eventually need to be replaced.

Symptoms that the TCD filaments may need replacing:

- A stable TCD baseline cannot be maintained.
- Data collection results in very high or very low peaks that are inconsistent with previous experience.
- During a data collection, no TCD signal is displayed on the main display, or the application indicates that no TCD signal is present.

Contamination of the thermal conductivity detector filaments will produce the symptoms described above. To clean the filaments, set the filament zone to 150 °C and flow an inert gas through the analyzer for several hours. If this action does not correct the problem, replace the TCD assembly.

REPLACE THE TCD ASSEMBLY

The equipment images in this topic may differ slightly from your equipment; however, the instructions are the same unless otherwise noted.

1. Ensure that no heat is being applied to the analyzer. If necessary, enable manual control and set the target temperature for the heat zones to ambient. Wait for the analyzer to cool.
2. Power OFF the analyzer but do NOT disconnect the power cord from the analyzer.



The power cord must remain connected to maintain an electrical ground connection to the analyzer.

3. Press in on the right side of the retractable handle on the top of the analyzer to protrude the handle. Use the handle to open the hinged top panel. It is not necessary to remove the top panel. Pull down the upper front panel.

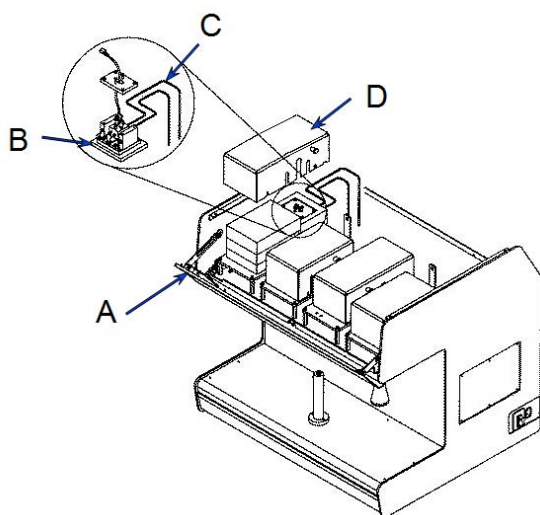

- A. Upper front panel
- B. TCD block
- C. TCD Assembly
- D. Bypass/Trap valve cover

4. Pull the Bypass/Trap valve cover retaining plungers outward until the Bypass/Trap valve cover is released. Pull the cover up and out.
5. Remove the insulation from the back of the Bypass/Trap valve and locate the TCD assembly (not shown).



The thermal conductivity detector assembly and nearby components may be hot. Allow the TCD to cool before removing it. Use the cotton gloves provided with the analyzer to protect your hands.

6. Loosen all four fittings for the stainless steel tubing. Label each piece of tubing for reconnection.
7. Unplug the TCD assembly cable from the card cage motherboard and cut the plastic cable ties that retain the various cables. This frees the cables for removal of the TCD and cable.

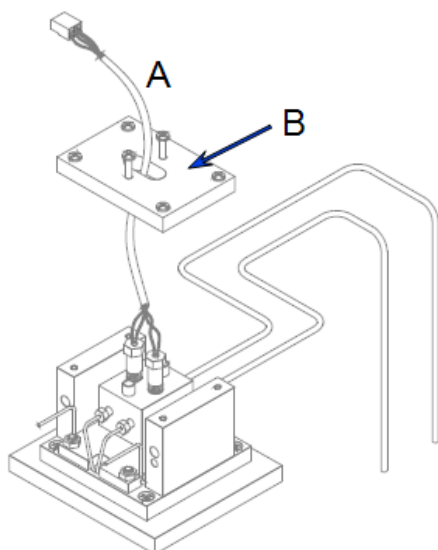

- A. TCD cable
- B. Mounting plate

8. Use a screwdriver to remove the two TCD mounting screws from the yoke plate. Lift the TCD assembly out of the analyzer.
9. Install the new TCD assembly in the analyzer. Reconnect the tubing at all four fittings and reconnect the cable to the card cage motherboard.
10. Reinstall the insulation in the back of Bypass/Trap valve over the TCD assembly.
11. Reinstall the Bypass/Trap valve cover and allow the retaining plungers to snap into place.
12. Close the top panel and the upper front panel.
13. Power ON the analyzer.
14. Adjust the filament temperature to 150 °C and select an inert carrier gas to flow through the TCD. Set the TCD Zone temperature to 110 °C.
15. Allow the TCD baseline to stabilize. Go to **Unit [n] > Show Status** to observe the TCD reading. Stabilization may take several hours.

CLEAN THE TCD ASSEMBLY

In some instances, contamination of the thermal conductivity detector filaments will produce the symptoms described above. To clean the filaments, set the filament zone to 150 °C and flow an inert gas through the analyzer for several hours. Contact your Micromeritics service representative if necessary.

11 ANALYSIS TUTORIALS

BET SURFACE AREA ANALYSIS

The BET Surface Area analysis evaluates total surface area of the catalyst before and after chemisorption. Loss of activity, which may occur due to the blocking of pores during the chemisorption reaction, as well as the occurrence of sintering of the support, can be studied.

After outgassing the sample, a mixture of 30% nitrogen and 70% helium is applied to the sample which is immersed in a liquid nitrogen (LN₂) bath. The amount of nitrogen adsorbed (usually measured on desorption) at LN₂ temperatures is used to calculate total surface area.

Because nitrogen uptake is a function of pore size, sample sintering can cause results to show reduced surface area. Therefore, it may be helpful to perform BET as the first and last experiments in the analysis in order to check for sintering of the support.

PREPARATION

| | |
|----------------------------|--|
| Pretreatment | Flow helium over the sample to remove impurities, usually at the maximum temperature tolerated by the sample (for example, the temperature at which the sample was calcined). |
| Analysis | Flow 30% N ₂ /He, using a Dewar of liquid nitrogen, to measure the uptake of nitrogen. Then remove the LN ₂ Dewar and replace it immediately with a Dewar of water at ambient temperature. The amount of N ₂ desorbed is measured and the BET equation is used to calculate the active surface area. |
| Cold Trap | Install the external long delay path. Do not use a cold trap Dewar. |
| Pressure regulator | For BET analysis, gas cylinders should be set to a level between 10 and 15 psig (69 and 103.5 kPag). |
| Furnace temperature | During pretreatment, select a temperature high enough to remove contaminants or moisture, but not so high as to cause sintering or fusing of the sample. Hold the temperature long enough to remove contaminants or moisture. Maintain the target temperature for at least 30 minutes to ensure adequate degassing. Ensure the <i>Done</i> step is set to return the sample temperature to 0 °C. |

CALIBRATION

BET experiments require a separate calibration consisting of three manual injections of nitrogen through the septum. This calibration can be performed either before or after the BET analysis. As with all TCD calibrations, use the Peak Editor to associate the calibration file with the analysis file. For this reason, it is necessary that the data on the manual injections are collected in a separate experiment from the BET experiment. The injections may be included in the same analysis as the BET experiment, or they may be performed as a completely separate analysis. Use the same recording options (zero, invert) for the Calibration experiment and the BET experiment.

The following method includes the calibration injections as a separate experiment which follows the BET experiment in the analysis.

INJECTION SIZE

Inject three volumes of gas with the goal of approximating the volume of gas taken up by the sample. Use one injection slightly larger than the expected volume, one injection slightly smaller than the expected volume, and one injection between these two volumes. The largest injection should be two to three times greater than the smallest injection.

Because the same syringe must be used for all three injections, select a syringe that can accommodate all three injection volumes. The volume of gas uptake can be estimated if the approximate surface area (SA) of the sample is known. Use the following formula to determine the approximate volume (V_m) to inject.

$$V_m(\text{cm}^3 \text{ STP}) = \frac{SA(\text{m}^2)}{(6.023 \times 10^{23} \text{ molecule/mole})(16.21 \times 10^{-20} \text{ m}^2/\text{molecule})} \times 22414 \text{ cm}^3/\text{mole}$$

So:

$$V_m(\text{cm}^3 \text{ STP}) = SA(\text{m}^2) \times 0.229$$

For example, a sample of 0.1 g of 50 m²/g material has a surface area of 5 m². Therefore, the volume of the gas which will be adsorbed is approximately 1.145 cm³ STP.

PROCEDURE



Before performing an analysis, ensure the sample and analyzer are adequately prepared.

1. Obtain the sample weight, then install the loaded sample tube and thermocouple on the analyzer.
2. Ensure the *Delay Path* is installed in the cold trap port.
3. Create a sample file containing the appropriate analysis conditions and report options.
 - a. Go to **File > New Sample**.
 - b. Complete the *Sample Description* window using appropriate values.
 - c. Select the *Analysis Conditions* tab and insert the following experiment steps:

| Insert Step | Window | Field | Field Entry or Selection |
|-------------|----------------|------------------------|---------------------------------------|
| Experiment | New Experiment | Experiment description | Enter a description of the experiment |
| | | Type of analysis | Physisorption Surface Area |
| | Zones | TCD Detector | |
| | | Block zone | 100 |
| | | Filament | 175 |
| | | Valve Zones | |
| | | Cold trap | 110 |
| | | Analysis | 110 |
| | | Loop | 110 |
| | | Vapor generator | 20 |
| | | Vapor Generator | |
| | | Reflux | 20 |
| | Flask | 20 | |
| | Gas Flows | Prep Gas | Helium |
| | | Carrier/Reference Gas | Helium |
| | | Loop Gas | None |
| | | Rate | 50 cm ³ /min |
| | | Cold trap valve | Trap |
| | | Analysis valve | Prepare |
| | | Loop valve | Fill |
| Vapor valve | Bypass | | |

| Insert Step | Window | Field | Field Entry or Selection |
|--|-------------------|---------------------------------------|--|
| | Outputs | Outputs | Use default values |
| | Peaks | Peaks | Use default values |
| | Recording Options | Invert the TCD signal | Select this option |
| Temperature Ramp | Temperature Ramp | Ramp Type | Sample ramp |
| | | End temperature | 350 |
| | | Ramp rate | 50.0 |
| | | Hold time | 0.00 |
| | | Enable KwikCool | No |
| Temperature Ramp | Temperature Ramp | Ramp Type | Return to ambient |
| | | Enable KwikCool | Enable this selection |
| Change Gas Flows | Gas Flows | Prep Gas | None |
| | | Carrier/Reference Gas | Nitrogen-Helium |
| | | Loop Gas | None |
| | | Cold trap valve | Trap |
| | | Analysis valve | Analyze |
| | | Loop valve | Fill |
| | | Vapor valve | Bypass |
| Wait | Wait | Wait until baseline is stable | Select this option |
| Wait | Wait | Wait for operator | Click OK to proceed with physisorption measurement |
| Start Recording | Start Recording | One measurement every | 0.1 seconds |
| Dose | Dose | Get physisorption point | Select this option |
| The application automatically inserts a Stop Recording step when a Start Recording step is inserted. Ensure that a Dose step and a Temperature Ramp step is inserted within the Start/Stop Recording loop. | | | |
| Termination | Termination | Return to ambient temperature | Select this option |
| | | Leave detector enabled after analysis | Option is not selected |
| | | Zones | Not applicable |
| | | Gas Flows | Not applicable |

To include the calibration data collection (three manual injections through the septum) within this analysis but as a separate experiment, also insert the following steps (before the *Dose* step):

| Insert Step | Window | Field | Field Entry | |
|------------------------|-----------------------|-------------------------------|---------------------------------------|--|
| Experiment | New Experiment | Experiment description | Enter a description of the experiment | |
| | | Type of analysis | Other | |
| | Zones | TCD Detector | | |
| | | Block zone | 100 | |
| | | Filament | 175 | |
| | | Valve Zones | | |
| | | Cold trap | 110 | |
| | | Analysis | 110 | |
| | | Loop | 110 | |
| | | Vapor generator | 20 | |
| | | Vapor Generator | | |
| | | Reflux | 20 | |
| | Flask | 20 | | |
| | Gas Flows | Prep Gas | None | |
| | | Carrier/Reference Gas | Nitrogen-Helium | |
| | | Loop Gas | None | |
| | | Rate | 50 cm ³ /min | |
| | | Cold trap valve | Trap | |
| | | Analysis valve | Analyze | |
| | | Loop valve | Fill | |
| Vapor valve | | Bypass | | |
| Outputs | Outputs | Use default values | | |
| Peaks | Peaks | Use default values | | |
| Wait | Wait | Wait until baseline is stable | Select this option | |
| Start Recording | Start Recording | One measurement every | 0.1 seconds | |
| Start Repeat | Start Repeat Sequence | Repeat | 3 times | |

| Insert Step | Window | Field | Field Entry |
|--|--------|-------------------|--|
| Wait | Wait | Wait for operator | Prepare manual N ₂ injection. Click OK. |
| Dose | Dose | Manual injection | Select this option |
| The application automatically inserts a <i>Stop Repeat</i> step when a <i>Start Repeat</i> step is inserted. Ensure that a <i>Wait</i> step is inserted within the <i>Start/Stop Repeat</i> loop. | | | |
| The application automatically inserts a <i>Stop Recording</i> step when a <i>Start Recording</i> step is inserted. Ensure that the <i>Dose</i> step and the <i>Temperature Ramp</i> step is inserted within the <i>Start/Stop Record</i> loop. | | | |

- d. Select the *Report Options* tab and modify the values as needed.
- e. Click **Save**, then click **Close**.
4. Start the analysis.
 - a. Go to **Unit [n] > Sample Analysis** and select the sample file that was just created.
 - b. Edit the sample file as needed, but for this example, editing is not required. Click **Next**.
 - c. From the drop-down list, select the calibrations associated with each experiment in the sample file (if any). For this example, select *None*.
 - d. Click **Next**.
 - e. Read the cautionary window and make any necessary changes. Click **Start** to start the analysis. During the analysis, change the Dewar when prompted.



Change the Dewar rapidly. It is recommended to hold the water Dewar in one hand and remove the LN₂ Dewar with the other to minimize the time required for the change.

5. When the analysis ends, remove the sample tube from the analyzer, place the caps on the tube, and dry off the outside of the tube with a paper towel.
6. Weigh the sample tube, sample, and caps. Subtract this weight from the weight obtained for the sample tube and caps. The resulting weight is the dry sample weight (the *after analysis weight*). This weight will be used when calculating the BET surface area in the following sections.



Use the cotton gloves provided in the accessory kit when handling heated surfaces. These cotton gloves are not intended to protect hands when heated surfaces are above 60 °C.

GENERATE THE BET REPORT

The following tasks must be performed before generating the BET report:

- Edit the sample file and the calibration file to ensure that peaks are properly marked
- Create a TCD calibration file
- Associate the TCD calibration file with the sample file

After completion of these tasks, go to **Reports > Start Report**. Verify that *BET Surface Area* is selected.

EDIT THE PEAKS IN THE SAMPLE FILE

1. Open the Peak Editor.
2. Select the *Peak Editor* experiment from the view selector drop-down list at the bottom of the window.
3. Select *Edit Peaks* in the *View Type* group box.
4. Click **Find All Peaks**.
5. If needed, edit the peak markers of the desorption peak:



The desorption peak is most often used to determine the surface area because the desorption process starts with the adsorbate equilibrated on the surface.

- a. Drag the cursor over the entire baseline of the peak to enlarge the editing area.
- b. Click on the baseline of the left side of the peak, right click and select *Mark left edge*.
- c. Repeat step b for the right side of the peak.
6. As the peak edges are adjusted, the values associated with the peak (listed in the peak table) are also adjusted. When satisfied with the appearance of the peak, right click and select **Save**.

EDIT THE PEAKS IN THE CALIBRATION FILE

1. Click **Calibration**.
2. Select the calibration file used with the analysis. Click **OK**.
3. Edit the peaks in the same manner as described for the sample file.

Create the TCD calibration file

1. Go to **Options > Signal Calibration > New**.
2. Select **User defined** and enable an Experiment. Click **OK**.

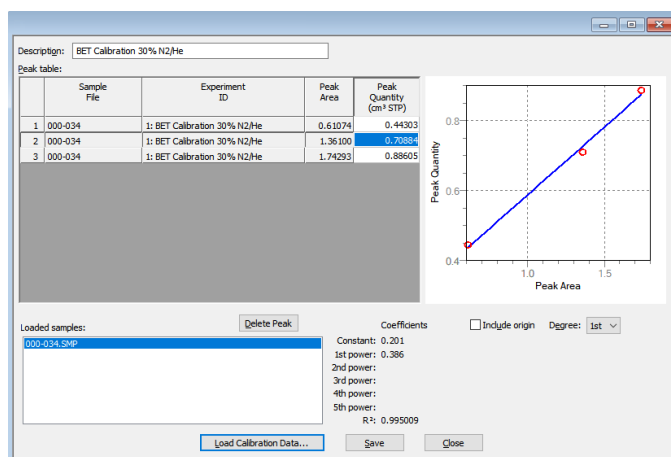
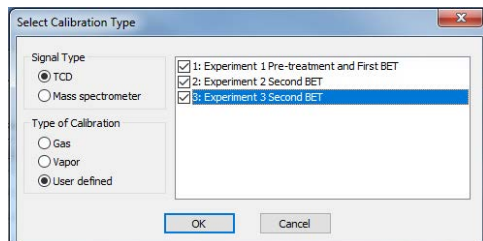

3. Click **Load Calibration Data**.
4. Select the sample file containing the calibration data. Click **OK**. The data in the file are inserted into the appropriate fields of the Signal Calibration window.
5. The values in the *Peak Quantity* column are defaults. The correct values for the volume of each injection at STP must be determined using the formula:

$$V_{STP} = V(injected) \left(\frac{273.15}{273.15 + ambient\ temp} \right) \times \left(\frac{ambient\ pressure}{760mm.Hg} \right)$$

Determine the volumes for each calibration peak listed in the table.

6. Enter the converted values (cm³ STP) into the table. Assess the Peak Area plot, Goodness of Fit, and Coefficients to decide if the calibration file is acceptable. Use your laboratory's standards to determine what level of linearity is acceptable. As a general guideline, use a calibration file with a very low value for Goodness of Fit (less than 0.1), when 1st or 2nd Degree is specified.

To delete peaks that are outliers, highlight the peak data in the table and click **Delete Peak**. Evaluate the results when changing the degree (select a different degree from the drop-down list).

7. Enter a new description into the *Description* field.
8. When satisfied with all values in the file, click **Save**, then click **Close**

Associate the Calibration file with the Sample file

1. Open the Peak Editor.
2. Select the *Peak Editor* experiment from the view selector drop-down list at the bottom of the window.
3. Select the experiment and click the **Calibration** button.
4. Select the down-arrow to the right of the *Calibration* field. Select the calibration file just created. Click **OK**.
5. Repeat steps 3 and 4 for each experiment.
6. Click **Save**, then click **Close**.

LOOP CALIBRATION FOR TCD ANALYZERS TUTORIAL

[Septum on page 9 - 28](#)

Each calibration loop must be calibrated prior to its first use to determine its precise volume under local conditions. Calibration consists of:

- Determining the average area of a series of peaks generated by injections of a known volume of gas through the analyzer septum using a syringe.
- Determining the average area of a series of peaks generated by injections of the same gas using the analyzer's internal loop.
- Calculating the volume of the loop by comparing the average peak area generated by the loop injections with that generated by the syringe injections.
- Entering the calculated loop volume under **Unit [n] > Unit Configuration**.

STEP 1: UPDATE AMBIENT PRESSURE AND TEMPERATURE

Options > Environmental Defaults

[Environmental Defaults for TCD Analyzers on page 2 - 12](#)

Ambient pressure and temperature at the time of the analysis affect the results of a loop calibration. In calculations, the analyzer uses the ambient pressure and temperature recorded in *Environmental Defaults*. Check and update the *Environmental Defaults* before beginning a loop calibration.

STEP 2: CREATE A SAMPLE FILE

Create the sample file and insert a *Loop Calibration* experiment on the *Analysis Conditions* tab.



A loop calibration must be created for each loop. For Loop Calibration, select a carrier gas, flow rate, and loop gas that will commonly be used for sample analyses.

STEP 3: PERFORM THE ANALYSIS

1. Install the correct injection loop.
2. Go to **Unit > Sample Analysis** and select the sample file for the loop calibration.
3. Click **Next** to accept the default values, then click **Start**.
4. Follow the prompts to make the selected number of injections. Use a volume that is close to the volume of the loop being calibrated. For example, if calibrating the 1 cm³ loop, use a 1 cm³ syringe and inject as close to 1 cm³ of gas as possible.



Pay close attention to the instructions provided in each prompt and perform the steps in the order given. Most accurate data results from keeping injection size as consistent as possible. Injection errors may be evident in the data and may make it necessary to repeat the experiment.

After the last manual injection, the analyzer automatically makes the same number of injections using the loop.

STEP 4: GENERATE THE REPORT

[Peak Editor on page 6 - 3](#)

When properly performed, each manual and automatic injection results in a peak. When the *Results* view of the *Start Analysis* window is selected, each peak can be viewed as it is collected. The area under the peak corresponds to the amount of gas injected.

1. In the *Peak Editor*, open the sample file to ensure the peaks are properly marked.
2. Go to **File > Open > [.SMP]** and open the .SMP file containing the calibration experiment and verify (or correct) the defined peaks using the *Peak Editor*.
3. On the *Reports* tab, select only the *Loop Calibration* report option.
4. Go to **Unit > Unit Configuration**. In the *Loop volume* field, enter the *Loop Volume*.



Verify that the *Loop Volume* and *Environmental Default* values are correct prior to starting an analysis with injections.

GENERATE THE LOOP CALIBRATION REPORT

[Peak Editor on page 6 - 3](#)

Open the Peak Editor and ensure that peaks are properly marked.

There are three possibilities for each dose of gas injected during Pulse chemisorption :

- all of the gas is taken up by the sample,
- some of the gas is taken up by the sample, or
- none of the gas is taken up by the sample.

When pulse chemisorption is properly performed, there will be some injections of each type. When the data is viewed using the Peak Editor, however, only those injections in which some or none of the gas is taken up will appear as peaks. When all of the gas is taken up by the sample, none of it reaches the detector and, therefore, the peak area is zero. These types of peaks are detected automatically by the application and do not require marking.

1. Go to **File > Open > .SMP file**.
2. Select the sample file used with this analysis. Click **OK**.
3. Select the *Report Options* tab.
4. Enter the percent of active gas in the *Active concentration* field.
5. On the Sample Description tab, click **Active Metals**.
6. Verify that the *Stoichiometry Factor* and the *% of Sample Weight* values are correct.
7. Click **OK**.
8. Verify that the values for the physical injection volume, ambient temperature, and ambient pressure are accurate.
9. Go to **Reports > Start Report** to generate the report.

PULSE CHEMISORPTION ANALYSIS TUTORIAL

A Pulse chemisorption analysis determines active surface area, percent metal dispersion, and active particle size by applying measured pulses of reactant gas to the sample, depending upon what technique is used. Pulse chemisorption is performed in the same manner as TPD, except that the sample is dosed with the analysis gas using the injection loop until each active site has reacted. After the active sites have completely reacted, the discretely injected gas volumes emerge unchanged. If TPD is performed after Pulse chemisorption, additional information about the distribution of active sites and the strength of active sites is collected.

The amount chemisorbed is the difference between the total amount of reactant gas injected and the amount that did not react with the active sites of the sample. The size of each pulse is determined by the loop, which is located on an electrically operated valve.

LOOP VOLUME

It is preferred for the sample to require at least two doses of gas, but no more than ten doses, before the reaction ends — depending on the environment. Some factors that influence the number of doses required are sample size, the active surface area per unit of sample, and the size of the loop. If the pulse chemisorption analysis requires more doses or fewer doses, change either the sample size or the loop size.

Three loops of different sizes are provided with the analyzer — each loop must be calibrated prior to use. As an alternative to replacing the loop, the loop volume may be changed by adjusting its temperature. If the loop volume is changed by changing its temperature, results will be more accurate if the loop volume is recalibrated at the new temperature.

LOOP CALIBRATION

Before data from an analysis that uses an injection loop can be reduced, a loop calibration experiment must be performed. An independent loop calibration can be performed either before or after the analysis.

The following example assumes that the loop calibration will be performed after the analysis. A *Loop Calibration* step can be included in a pulse chemisorption analysis.

PREPARATION

| | |
|----------------------------|---|
| Pretreatment | Degas by flowing inert gas (such as helium, argon, or nitrogen) over the sample while ramping the temperature. |
| Analysis | Pulse the loop (analysis) gas over the sample until the peak area remains constant. |
| Cold Trap | No cold trap is needed during pretreatment. During the analysis, use the cold trap fixture with a Dewar of water in place as a short delay path. This delay compensates for the flow disturbance caused by each loop injection. |
| Pressure regulator | Gas cylinders should be set to a level between 10 and 15 psig (69 and 103.5 kPag). |
| Furnace temperature | Select a temperature high enough to remove any contaminants or moisture, but not so high as to cause sintering or fusing of the sample. Ensure the <i>Done</i> step is set to return the sample temperature to ambient. |

PROCEDURE



In the following example, Pulse chemisorption is performed on a sample of Pt/Al₂O₃ with CO. Alter the analysis conditions to accommodate a different analysis.



Before performing an analysis, ensure the sample and analyzer are adequately prepared. See [Prepare for Analysis on page 5 - 5](#).

1. Obtain the sample mass, then install the loaded sample tube and thermocouple on the analyzer. Close the furnace around the sample tube.
2. Create a sample file for this analysis.
 - a. Complete the *Sample Description* tab. Enter the correct mass and complete the optional fields.
 - b. Select the *Analysis Conditions* tab and insert the experiment steps listed below:

| Insert Step | Window | Field | Field Entry or Selection |
|-------------|----------------|------------------------|---------------------------------------|
| Experiment | New Experiment | Experiment description | Enter a description of the experiment |
| | | Type of analysis | Pulse Chemisorption |
| | Zones | TCD Detector | |
| | | Block zone | 100 |
| | | Filament | 175 |
| | | Valve Zones | |
| | | Cold trap | 110 |
| | | Analysis | 110 |
| | | Loop | 110 |
| | | Vapor generator | 20 |
| | | Vapor Generator | |
| | | Reflux | 20 |
| | | Flask | 20 |

| Insert Step | Window | Field | Field Entry or Selection |
|-------------------------|------------------|-----------------------|--------------------------|
| | Gas Flows | Prep Gas | Helium |
| | | Carrier/Reference Gas | Helium |
| | | Loop Gas | None |
| | | Rate | 50 cm ³ /min |
| | | Cold trap valve | Trap |
| | | Analysis valve | Analyze |
| | | Loop valve | Fill |
| | | Vapor valve | Bypass |
| | Outputs | Outputs | Use default values |
| | Peaks | Peaks | Use default values |
| Wait | Wait | Wait [n] minutes | 5 |
| Change Gas Flows | Gas Flows | Prep Gas | Hydrogen |
| | | Carrier/Reference Gas | Helium |
| | | Loop Gas | None |
| | | Cold trap valve | Bypass |
| | | Analysis valve | Prepare |
| | | Loop valve | Fill |
| | | Vapor valve | Bypass |
| Temperature Ramp | Temperature Ramp | Ramp Type | Sample ramp |
| | | End temperature | 120 |
| | | Ramp rate | 10.0 |
| | | Hold time | 30 |
| Temperature Ramp | Temperature Ramp | Ramp Type | Sample ramp |
| | | End temperature | 220 |
| | | Ramp rate | 10.0 |
| | | Hold time | 30 |
| Temperature Ramp | Temperature Ramp | Ramp Type | Sample ramp |
| | | End temperature | 350 |
| | | Ramp rate | 10.0 |
| | | Hold time | 120.0 |

| Insert Step | Window | Field | Field Entry or Selection |
|---|-----------------------|---|--------------------------|
| Change Gas Flows | Gas Flows | Prep Gas | Helium |
| | | Carrier/Reference Gas | Helium |
| | | Loop Gas | None |
| | | Cold trap valve | Bypass |
| | | Analysis valve | Prepare |
| | | Loop valve | Fill |
| | | Vapor valve | Bypass |
| Wait | Wait | Wait [n] minutes | 90 |
| Temperature Ramp | Temperature Ramp | Ramp Type | Return to ambient |
| Wait | Wait | Wait [n] minutes | 30 |
| Temperature Ramp | Temperature Ramp | Ramp Type | Sample ramp |
| | | End temperature | 35 |
| | | Ramp rate | 5.0 |
| | | Hold time | 10.0 |
| Change Gas Flows | Change Gas Flows | Prep Gas | None |
| | | Carrier/Reference Gas | Helium |
| | | Loop Gas | Carbon Monoxide |
| | | Cold trap valve | Trap |
| | | Analysis valve | Analyze |
| | | Loop valve | Fill |
| | | Vapor valve | Bypass |
| Wait | Wait | Wait until baseline is stable | Select this option |
| Start Recording | Start Recording | One measurement every | 0.2 second |
| Wait | Wait | Wait [n] minutes | 3 |
| Start Repeat | Start Repeat Sequence | Repeat until peaks are equal or [n] times | 20 |
| Dose | Dose | Inject Loop Gas | Select this option |
| | | Wait for [n] minutes | 1.5 |
| <p>The application automatically inserts a <i>Stop Repeat</i> step when a <i>Start Repeat</i> step is inserted. Ensure that the <i>Dose</i> step is inserted within the <i>Start/Stop Repeat</i> loop.</p> | | | |

| Insert Step | Window | Field | Field Entry or Selection |
|---|-------------|---------------------------------------|--------------------------|
| <p>The application automatically inserts a Stop Recording step when a Start Recording step is inserted. Ensure that the Temperature Ramp step is inserted within the Start/Stop Recording loop.</p> | | | |
| Termination | Termination | Return to ambient temperature | Select this option |
| | | Leave detector enabled after analysis | Option is not selected |
| | | Zones | Not applicable |
| | | Gas Flows | Not applicable |

- d. Select the *Report Options* tab and modify values as needed.
- e. Click **Save**, then click **Close**.
3. Start the analysis.
 - a. Go to **Unit > Sample Analysis**. From the *Files* list box, select the sample file created in the previous step. Edit the file as needed. Click **Next**.
 - b. From the drop-down list, select the calibrations associated with each experiment in the sample file (if any). For this example, select *None*. Click **Next**.



Calibration files can also be associated with a sample file after analysis using **Calibration** button in the Peak Editor.

- c. Read the cautionary window and make any necessary changes.
- d. Click **Start** to start the analysis.

When the analysis ends, the furnace begins to lower the sample to room temperature. To speed cooling of the sample, use the optional CryoCooler or KwikCool.



Use the cotton gloves provided in the accessory kit when handling heated surfaces. These cotton gloves are not intended to protect hands when heated surfaces are above 60 °C.

When the displayed sample temperature reaches the ambient temperature, open the furnace. Using gloves, remove the sample tube.

GENERATE THE LOOP CALIBRATION REPORT

[Peak Editor on page 6 - 3](#)

Open the Peak Editor and ensure that peaks are properly marked.

There are three possibilities for each dose of gas injected during Pulse chemisorption:

- all of the gas is taken up by the sample,
- some of the gas is taken up by the sample, or
- none of the gas is taken up by the sample.

When pulse chemisorption is properly performed, there will be some injections of each type. When the data is viewed using the Peak Editor, however, only those injections in which some or none of the gas is taken up will appear as peaks. When all of the gas is taken up by the sample, none of it reaches the detector and, therefore, the peak area is zero. These types of peaks are detected automatically by the application and do not require marking.

1. Go to **File > Open > .SMP file**.
2. Select the sample file used with this analysis. Click **OK**.
3. On the *Sample Description* tab, click **Active Metals**. Verify that the *Stoichiometry Factor* and the *% of Sample Weight* values are correct. Click **OK**.
4. Verify that the values for the physical injection volume, ambient temperature, and ambient pressure are accurate.
5. Go to **Reports > Start Report** to generate the report.

TEMPERATURE PROGRAMMED DESORPTION ANALYSIS



This topic provides an example of how to perform a Temperature Programmed Desorption analysis using NH_3 on calcium oxalate under helium with a $10\text{ }^\circ\text{C}/\text{min}$ temperature ramp. Make the appropriate modifications for the material being analyzed.

Temperature Programmed Desorption (TPD) analyses determine the quantity, type, and strength of active sites available on the surface of a catalyst from measurement of the amount of gas desorbed at various temperatures.

After the sample has been outgassed, reduced, or otherwise prepared, a steady stream of analysis gas flows over the sample and reacts with the active sites. (Alternatively, Pulse chemisorption can be used to react with active sites.) Programmed desorption begins when the temperature is ramped linearly over time while a constant stream of inert carrier gas passes over the sample.

At a certain temperature, the heat will overcome the activation energy, breaking the bond between the adsorbate and adsorbent. The adsorbed species will then desorb. If different active metals are present, they usually will desorb the reacted species at different temperatures. The desorbed molecules enter the stream of inert carrier gas and are swept to the detector where the detector response is proportional to the gas concentrations. The quantity of desorbed species, combined with the stoichiometry factor, and the temperature at which pre-adsorbed species desorb, yield the quantity and strength of active sites, respectively.

If TPD is performed after coverage of the active sites by flow or pulse chemisorption, additional information about the distribution of active sites and the strength of active sites is collected.

PREPARATION



Before performing an analysis, ensure the sample and analyzer are adequately prepared. See [Prepare for Analysis on page 5 - 5](#).

| | |
|---------------------|--|
| Pretreatment | Degas by flowing inert gas — such as helium, argon, or nitrogen — over the sample while ramping the temperature. |
| Analysis | Choose a gas mixture from the following table based on the needed results. Flow the gas over the sample, then ramp the temperature beginning at ambient. |
| Cold Trap | Not required |

| Needed Results | Carrier Gas | Analysis Gas |
|--|-------------|---|
| Active Metal Surface Area H ₂ Chemisorption | argon | hydrogen |
| Active Metal Surface Area CO Chemisorption | helium | carbon monoxide |
| Acidity | helium | ammonia (15% maximum NH ₃ , blended in helium) |



Before performing an analysis, ensure the sample and analyzer have been adequately prepared.

PROCEDURE

These instructions analyze zeolite with ammonia (use 15% maximum NH₃ blended in helium) at 3 to 20 °C/min. Adjust the values in the example to accommodate the analysis you are performing.

1. Obtain the sample weight, then install the loaded sample tube and thermocouple on the analyzer. Close the furnace around the sample tube.
2. Create a sample file for this analysis.
 - a. Go to **File > New Sample**.
 - b. Complete the *Sample Description* window. Enter the correct mass and complete the optional fields as needed.
 - c. Select the *Analysis Conditions* tab and insert the following experiment steps:

| Insert Step | Window | Field | Field Entry or Selection | |
|-------------|----------------|------------------------|---------------------------------------|--|
| Experiment | New Experiment | Experiment description | Enter a description of the experiment | |
| | | Type of analysis | Other | |
| | Zones | TCD Detector | | |
| | | Block zone | 100 | |
| | | Filament | 175 | |
| | | Valve Zones | | |
| | | Cold trap | 110 | |
| | | Analysis | 110 | |
| | | Loop | 110 | |
| | | Vapor generator | 20 | |
| | | Vapor Generator | | |
| | | Reflux | 20 | |
| | Flask | 20 | | |
| | Gas Flows | Prep Gas | Helium | |
| | | Carrier/Reference Gas | Helium | |
| | | Loop Gas | None | |
| | | Rate | 50 cm ³ /min | |
| | | Cold trap valve | Bypass | |
| | | Analysis valve | Prepare | |
| | | Loop valve | Fill | |
| | | Vapor valve | Bypass | |

| Insert Step | Window | Field | Field Entry or Selection |
|-------------------------|------------------|------------------------|---------------------------------------|
| | Outputs | Outputs | Use default values |
| | Peaks | Peaks | Use default values |
| Temperature Ramp | Temperature Ramp | Ramp Type | Sample ramp |
| | | End temperature | 350 |
| | | Ramp rate | 50.0 |
| | | Hold time | 10.00 |
| Experiment | New Experiment | Experiment description | Enter a description of the experiment |
| | | Type of analysis | Temperature Programmed Desorption |
| | Zones | TCD Detector | |
| | | Block zone | 100 |
| | | Filament | 175 |
| | | Valve Zones | |
| | | Cold trap | 110 |
| | | Analysis | 110 |
| | | Loop | 110 |
| | | Vapor generator | 50 |
| | | Vapor Generator | |
| | | Reflux | 40 |
| | Flask | 50 | |
| | Gas Flows | Prep Gas | Helium |
| | | Carrier/Reference Gas | Helium |
| | | Loop Gas | None |
| | | Rate | 50 cm ³ /min |
| | | Cold trap valve | Bypass |
| | | Analysis valve | Prepare |
| | | Loop valve | Fill |
| Vapor valve | | Bypass | |
| Outputs | Outputs | Use default values | |
| Peaks | Peaks | Use default values | |
| Temperature Ramp | Temperature Ramp | Ramp Type | Return to ambient |

| Insert Step | Window | Field | Field Entry or Selection |
|---|------------------|-------------------------------|---|
| Change Gas Flows | Gas Flows | Prep Gas | Ammonia (15% maximum NH ₃ blended in helium) |
| | | Carrier/Reference Gas | Helium |
| | | Loop Gas | Ammonia (15% maximum NH ₃ blended in helium) |
| | | Rate | 50 cm ³ /min |
| | | Cold trap valve | Bypass |
| | | Analysis valve | Prepare |
| | | Loop valve | Fill |
| | | Vapor valve | Bypass |
| Wait | Wait | Wait [n] minutes | 60 |
| Change Gas Flows | Gas Flows | Prep Gas | None |
| | | Carrier/Reference Gas | Helium |
| | | Loop Gas | Ammonia (15% maximum NH ₃ blended in helium) |
| | | Cold trap valve | Bypass |
| | | Analysis valve | Analyze |
| | | Loop valve | Fill |
| | | Vapor valve | Bypass |
| Wait | Wait | Wait [n] minutes | 30 |
| Wait | Wait | Wait until baseline is stable | Select this option |
| Start Recording | Start Recording | One measurement every | 1.0 seconds |
| Temperature Ramp | Temperature Ramp | Ramp Type | Sample ramp |
| | | End temperature | 500 |
| | | Ramp rate | 3.0 |
| | | Hold time | 0.0 |
| <p>The application automatically inserts a Stop Recording step when a Start Recording step is inserted. Ensure that the Temperature Ramp step is inserted within the Start/Stop Recording loop.</p> | | | |

| Insert Step | Window | Field | Field Entry or Selection |
|---|------------------|---------------------------------------|--------------------------|
| Wait | Wait | Wait [n] minutes | 30 |
| Temperature Ramp | Temperature Ramp | Ramp Type | Return to ambient |
| Repeatedly insert the steps between the double lines in this table. Use a different ramp rate for each repetition; after ramping at 3°/min. and 5°/min., use 10, 15, and 20°/min. This shifts the peak as a function of the Heat of Desorption. | | | |
| Termination | Termination | Return to ambient temperature | Select this option |
| | | Leave detector enabled after analysis | Option is not selected |
| | | Zones | Not applicable |
| | | Gas Flows | Not applicable |

- d. Select the *Report Options* tab and set the values. Click **Save** then click **Close**.
3. Start the analysis.
 - a. Go to **Unit > Sample Analysis**. From the *Files* list box, select the sample file created in the previous step. Edit the file as needed. Click **Next**.
 - b. From the drop-down list, select the calibrations associated with each experiment in the sample file (if any). For this example, select *None*. Click **Next**.
 - c. Read the cautionary window and make any necessary changes.
 - d. Click **Start** to start the analysis.



When the analysis ends, the furnace begins to lower the sample to room temperature. To speed cooling of the sample, use the optional CryoCooler or AutoCool. Remove the sample tube when the analysis is complete.



Use the cotton gloves provided in the accessory kit when handling heated surfaces. These cotton gloves are not intended to protect hands when heated surfaces are above 60 °C.

TEMPERATURE PROGRAMMED OXIDATION ANALYSIS



This topic provides an example of performing a TPO on WO_3 . Because TPR is often used as the preparation for TPO, the TPR process was included in this example.

Temperature Programmed Oxidation (TPO) examines the extent to which a catalyst can be re-oxidized. Generally, TPO analyses are used to measure the degree of reduction of certain oxides.

Usually the sample is pretreated and the metal oxides are reduced to the base metal. Then the reactant gas is applied to the sample in pulses or (alternatively) as a steady stream. The analyzer measures the uptake of the reactant gas.

TPO is often performed after TPR is performed. When the TPR experiment concludes, the sample is returned to room temperature. Then, the analysis gas is changed to 2-5% O_2 + He. This gas mixture is flowed after the sample is at ambient temperature, then the temperature is ramped up to the same maximum temperature used for the preceding TPR analysis. The portion of the sample that had been reduced is re-oxidized, and the degree of reduction can be calculated.

If the TPR and TPO results are different, there are several possible causes: the sample material sintered such that only a surface oxide (and not a bulk oxide) is formed, or part of the sample was re-oxidized at room temperature while the TCD baseline was stabilizing.



When using any mixture of gases for TPR or TPO analyses, make sure the thermal conductivities of the two gases in the mixture are quite different for maximum sensitivity, See [Gas Charts on page E - 1](#).

PREPARATION

| | |
|---------------------|---|
| Pretreatment | TPR |
| Analysis | 2 to 5% oxygen/helium is flowed through the sample while temperature is ramped, beginning at ambient temperature. |
| Cold Trap | None needed. |



Before performing an analysis, ensure the sample and analyzer are adequately prepared. See [Prepare for Analysis on page 5 - 5](#).

PROCEDURE

1. Obtain the sample weight, then install the loaded sample tube and thermocouple on the analyzer. Close the furnace around the sample tube.
2. Create a sample file for this analysis.
 - a. Go to **File > New Sample**. Enter a file name or accept the default. Click **OK**, then click **Yes** to confirm.
 - b. Complete the Sample file as needed.
 - c. Select the *Analysis Conditions* tab and insert the experiment steps in the following table:

| Insert Step | Window | Field | Field Entry |
|-------------|----------------|------------------------|---|
| Experiment | New Experiment | Experiment description | Enter a description of the experiment |
| | | Type of analysis | Temperature Programmed Reduction |
| | Zones | TCD Detector | |
| | | Block zone | 100 |
| | | Filament | 175 |
| | | Valve Zones | |
| | | Cold trap | 110 |
| | | Analysis | 110 |
| | | Loop | 110 |
| | | Vapor generator | 20 |
| | | Vapor Generator | |
| | | Reflux | 20 |
| | | Flask | 20 |
| | Gas Flows | Prep Gas | Helium |
| | | Carrier/Reference Gas | Hydrogen-Argon (blend of 10% hydrogen in argon) |
| | | Loop Gas | None |
| | | Rate | 50 cm ³ /min |
| | | Cold trap valve | Trap |
| | | Analysis valve | Prepare |
| | | Loop valve | Fill |
| | | Vapor valve | Bypass |
| | Outputs | Outputs | Use default values |

| Insert Step | Window | Field | Field Entry |
|--|------------------|-------------------------------|---|
| | Peaks | Peaks | Use default values |
| Temperature Ramp | Temperature Ramp | Ramp Type | Return to ambient |
| Change Gas Flows | Gas flows | Prep Gas | None |
| | | Carrier/Reference Gas | Hydrogen-Argon (blend of 10% hydrogen in argon) |
| | | Loop Gas | None |
| | | Cold trap valve | Bypass |
| | | Analysis valve | Analyze |
| | | Loop valve | Fill |
| | | Vapor valve | Bypass |
| Wait | Wait | Wait for operator | Position cold trap Dewar and close furnace |
| Wait | Wait | Wait until baseline is stable | Select this option |
| Start Recording | Start Recording | One measurement every | 1.0 seconds |
| Temperature Ramp | Temperature Ramp | Ramp Type | Sample ramp |
| | | End temperature | 980 |
| | | Ramp rate | 10.0 |
| | | Hold time | 0.00 |
| <p>The application automatically inserts a <i>Stop Recording</i> step when a <i>Start Recording</i> step is inserted. Ensure that the <i>Temperature Ramp</i> step is inserted within the <i>Start/Stop Recording</i> loop.</p> | | | |
| Change Gas Flows | Gas Flows | Prep Gas | Helium |
| | | Carrier/Reference Gas | Helium |
| | | Loop Gas | None |
| | | Cold trap valve | Bypass |
| | | Analysis valve | Prepare |
| | | Loop valve | Fill |
| | | Vapor valve | Bypass |
| Temperature Ramp | Temperature Ramp | Ramp Type | Return to ambient |

| Insert Step | Window | Field | Field Entry | |
|-------------------------|------------------|-------------------------------|---------------------------------------|--|
| Experiment | New Experiment | Experiment Description | Enter a description of the experiment | |
| | | Type of analysis | Temperature Programmed Oxidation | |
| | Zones | TCD Detector | | |
| | | Block zone | 100 | |
| | | Filament | 175 | |
| | | Valve Zones | | |
| | | Cold trap | 110 | |
| | | Analysis | 110 | |
| | | Loop | 110 | |
| | | Vapor generator | 20 | |
| | | Vapor Generator | | |
| | | Reflux | 20 | |
| | | Flask | 20 | |
| | Gas Flows | Prep Gas | Helium | |
| | | Carrier/Reference Gas | Helium | |
| | | Loop Gas | None | |
| | | Rate | 50 cm ³ /min | |
| | | Cold trap valve | Bypass | |
| | | Analysis valve | Prepare | |
| Loop valve | | Fill | | |
| Vapor valve | | Bypass | | |
| Outputs | Outputs | Use default values | | |
| Peaks | Peaks | Use default values | | |
| Wait | Wait | Wait until baseline is stable | Select this option | |
| Start Recording | Start Recording | One measurement every | 1.0 seconds | |
| Temperature Ramp | Temperature Ramp | Ramp Type | Sample ramp | |
| | | End temperature | 980 | |
| | | Ramp rate | 20.0 | |
| | | Hold time | 0.00 | |

| Insert Step | Window | Field | Field Entry |
|---|------------------|---------------------------------------|------------------------|
| <p>The application automatically inserts a <i>Stop Recording</i> step when a <i>Start Recording</i> step is inserted. Ensure that the <i>Temperature Ramp</i> step is inserted within the <i>Start/Stop Recording</i> loop.</p> | | | |
| Change Gas Flows | Gas Flows | Prep Gas | Helium |
| | | Carrier/Reference Gas | Helium |
| | | Loop Gas | None |
| | | Cold trap valve | Bypass |
| | | Analysis valve | Prepare |
| | | Loop valve | Fill |
| | | Vapor valve | Bypass |
| Temperature Ramp | Temperature Ramp | Ramp Type | Return to ambient |
| Termination | Termination | Return to ambient temperature | Select this option |
| | | Leave detector enabled after analysis | Option is not selected |
| | | Zones | Not applicable |
| | | Gas Flows | Not applicable |

- d. Select the *Report Options* tab and set the values.
- e. Click **Save**, then click **Close**.
3. Start the analysis.
 - a. Go to **Unit > Sample Analysis**. From the *Files* list box, select the sample file created in the previous step. Edit the file as needed. Click **Next**.
 - b. From the drop-down list, select the calibrations associated with each experiment in the sample file (if any). For this example, select *None*. Click **Next**.
 - c. Read the cautionary window and make any necessary changes.
 - d. Click **Start** to start the analysis.



When the analysis ends, the furnace begins to lower the sample to room temperature. To speed cooling of the sample, use the optional CryoCooler or KwikCool. Remove the sample tube when the analysis is complete.

4. As the temperature increases, the sample is oxidized, and the application calculates the volume of oxygen taken up.

5. Allow the TCD signal to return to the initial baseline after the peak has been displayed
6. When the displayed sample temperature reaches the ambient temperature, open the furnace. Using gloves, remove the sample tube.



Use the cotton gloves provided in the accessory kit when handling heated surfaces. These cotton gloves are not intended to protect hands when heated surfaces are above 60 °C.

TEMPERATURE PROGRAMMED REDUCTION ANALYSIS



This topic provides an example of how to perform a TPR analysis of copper oxide. Copper Oxide Reference Material can be ordered from Micromeritics. Parts and accessories are located on the [Micromeritics](#) web page.



Some reactions begin at temperatures below ambient. In such cases, a Dewar containing an appropriate coolant should be used instead of the furnace at the beginning of the experiment. For example, reduction of PtO should begin at approximately -50 °C, because the reaction begins at about -30 °C. Alternatively, the optional CryoCooler can be used.

Temperature Programmed Reduction (TPR) determines the number of reducible species present in the catalyst and reveals the temperature at which reduction occurs. An important aspect of TPR analyses is that the sample need not have special characteristics other than containing reducible metals.

The TPR analysis begins by flowing analysis gas (typically hydrogen in an inert carrier gas such as nitrogen or argon) over the sample, usually starting at ambient temperature. While the gas is flowing, the temperature of the sample is increased linearly with time and the consumption of hydrogen by adsorption/reaction is monitored. Changes in the concentration of the gas mixture are determined. This information yields the hydrogen uptake volume.

PREPARATION

| | |
|---------------------|---|
| Pretreatment | Oxidize by flowing O ₂ over the sample. |
| Analysis | Flow 5-10% hydrogen/argon while ramping the temperature. The analyzer records hydrogen consumption as a function of temperature. Nitrogen is sometimes used because it may be more economical than argon. Argon is recommended over nitrogen because the resultant peak(s) show no reaction between sample and gas. |
| Cold Trap | A cold trap is required to remove traces of water formed as a product of the reduction. |



Before performing an analysis, ensure the sample and analyzer are adequately prepared. See [Prepare for Analysis on page 5 - 5](#).

PROCEDURE

[Sample Files on page 3 - 2](#)

[Peak Editor on page 6 - 3](#)

1. Obtain the sample mass then install the loaded sample tube on the analyzer. If the analysis begins below ambient, either place a Dewar of coolant around the sample tube or close the furnace around the sample tube and install the CryoCooler. If the analysis begins at ambient, close the furnace around the sample tube.
2. Install the cold trap (if using one), then place a Dewar filled with coolant around the cold trap. Ensure that the Dewar contains sufficient coolant to cover the cold trap loops.

A mixture of isopropyl alcohol (IPA) and liquid nitrogen (LN₂) is the recommended coolant for this experiment. Place the isopropyl alcohol in a Dewar and slowly pour LN₂ into the Dewar while stirring the mixture. Continue to add and stir the mixture until it becomes a slush. The mixture must be capable of achieving a temperature of about -90 °C.



Extreme caution should be used when mixing the IPA/LN₂. See [Dewar Precautions on page 5 - 3](#).

3. Create a sample file for this analysis.
 - a. Go to **File > New Sample**.
 - b. Complete the Sample Description window. Enter the correct weight and complete the optional fields.
 - c. Select the *Analysis Conditions* tab and insert the experiment steps listed below:

| Insert Step | Window | Field | Field Entry or Selection |
|-------------|----------------|------------------------|---------------------------------------|
| Experiment | New Experiment | Experiment description | Enter a description of the experiment |
| | | Type of analysis | Temperature Programmed Reduction |

| Insert Step | Window | Field | Field Entry or Selection |
|-------------------------|-----------------|-------------------------------|---|
| | Zones | TCD Detector | |
| | | Block zone | 100 |
| | | Filament | 175 |
| | | Valve Zones | |
| | | Cold trap | 110 |
| | | Analysis | 110 |
| | | Loop | 110 |
| | | Vapor generator | 40 |
| | | Vapor Generator | |
| | | Reflux | 40 |
| | Flask | 40 | |
| | Gas Flows | Prep Gas | Helium |
| | | Carrier/Reference Gas | Hydrogen-Argon (10% blend of hydrogen in argon) |
| | | Loop Gas | None |
| | | Rate | 50 cm ³ /min |
| | | Cold trap valve | Trap |
| | | Analysis valve | Prepare |
| Loop valve | | Fill | |
| Vapor valve | | Bypass | |
| Outputs | Outputs | Use default values | |
| Peaks | Peaks | Use default values | |
| Wait | Wait | Wait for operator | Add sample and setup cold trap |
| Change Gas Flows | Gas Flows | Prep | None |
| | | Carrier | Hydrogen-Argon (10% blend of hydrogen in argon) |
| | | Loop | None |
| | | Cold trap valve | Trap |
| | | Analysis valve | Analyze |
| | | Loop valve | Fill |
| | | Vapor valve | Bypass |
| Wait | Wait | Wait until baseline is stable | Select this option |
| Start Recording | Start Recording | One measurement every | 1.0 seconds |

| Insert Step | Window | Field | Field Entry or Selection |
|--|------------------|---------------------------------------|--------------------------|
| Temperature Ramp | Temperature Ramp | Type | Sample Ramp |
| | | End Temperature | 400 |
| | | Ramp Rate | 10.0 |
| | | Hold Time | 0.00 |
| The application automatically inserts a Stop Recording step when a Start Recording step is inserted. Ensure that the Temperature Ramp step is inserted within the Start/Stop Recording loop. | | | |
| Termination | Termination | Return to ambient temperature | Select this option |
| | | Leave detector enabled after analysis | Option is not selected |
| | | Zones | Not applicable |
| | | Gas Flows | Not applicable |

- d. Select the *Report Options* tab and modify the values as needed.
- e. Click **Save**, then click **Close**.
4. Start the analysis.
 - a. Go to **Unit > Sample Analysis**. From the *Files* list box, select the sample file created in the previous step. Edit the file as needed. Click **Next**.
 - b. From the drop-down list, select the calibrations associated with each experiment in the sample file (if any). For this example, select *None*. Click **Next**.



Calibration files can also be associated with a sample file after analysis using *Set Calibration in the Peak Editor*.

- c. Read the cautionary window and make any necessary changes.
- d. Click **Start** to start the analysis.

As the temperature increases, the copper oxide is reduced, the water produced by the reaction is collected in the cold trap (if used), and the amount of hydrogen consumed is detected and transmitted to the application. Use the *Results* view to display a chromatogram of the hydrogen consumed from the detector signal as a function of the ramping temperature.

A hydrogen consumption peak, which corresponds to the reduction capacity of copper oxide, is displayed. The maximum peak should occur at approximately 280 °C. This temperature varies highly, depending on the CuO particle size. Larger particle size shifts the temperature upward to 330 °C or more. Under certain combinations of sample, hydrogen concentration, and flow rate, two peaks may appear due to the transition state of Cu^{2+} to Cu^+ to Cu.

A ADVANCED REPORTS - PYTHON MODULE

- **Summary reports.** Consist of summary sections, each containing a two-column table of label and value pairs. Summary reports are created with the *mic.summary* call.
- **Tabular reports.** Consist of one or more tables each containing one or more labeled columns of data. Tabular reports are created with the *mic.table* call.
- **Graphical reports.** Consist of a single graph with one or more curves on one or two y-axes. Graphical reports are created with the *mic.graph* call.

Calls for accessing the sample file data can be found in the *Mic Module Python Calls* section of this appendix. More advanced example python scripts are included in the analyzer software.

ADVANCED REPORTS

Up to five Advanced reports, each with up to 10 summary reports, 10 tabular reports, and 10 graphical reports can be created. To use this feature, a file containing a Python script that imports a "mic" Python module must be created. See [MicModule Python Calls on page A - 11](#) for an example of a Python script and functions for the "mic" Python module.

1. Create the Python script and save it in the *Scripts* directory.
2. Open a sample file with a *Complete* status.
3. Select *Advanced* in the view selector drop-down list at the bottom of the window to return to the tabbed view.
4. On the *Report Options* tab, select *Advanced* in the *Selected Reports* list box, then click **Edit**.
5. On the *Advanced Report Options* window, click **Add** in the *Available Scripts* group box to locate and select the Python script. Repeat for each script to be added.

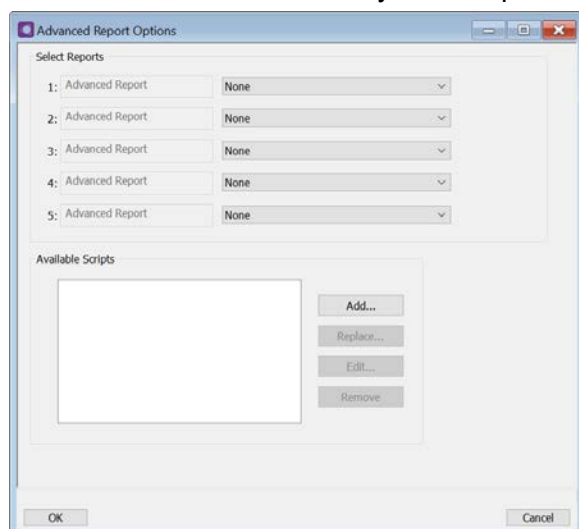

6. In the *Selected Reports* group box, click the drop-down arrows to select up to five Python scripts previously added in the *Available Scripts* box.
7. On the *Report Options* tab, click **Preview**. The Python Reports will be included on the tabs across the top portion of the *Reports* window.

Advanced Reports

| Selections | Description |
|---|--|
| Advanced Report 1 through 5 [drop-down box] | Use the drop-down lists to select currently-defined functions used to define the report calculations and output. |
| Available Scripts [group box] | Lists the available reports and provides the option to add, replace, edit, or remove reports. |
|  | For fields and buttons not listed in this table, see Common Fields and Buttons on page 2 - 4 . |

SCRIPTS

Run a Script

1. Open a sample file with a *Complete* file status.
2. Select *Advanced* in the view selector drop-down list at the bottom of the window.
3. Select the *Report Options* tab.
4. Highlight *Advanced* in the *Selected Reports* list box, then click **Edit**.
5. On the *Advanced Report Options* window, click **Add**.
6. Select one or more python scripts then click **Select**. The selected scripts become a part of the drop-down list in the *Available Scripts* section of the *Advanced Report Options* window.
7. In the *Select Reports* section, select up to five *Advanced* reports in the drop-down lists.
8. Click **OK**.
9. Click **Preview** on the *Report Options* tab to view all reports selected in the previous window.

Remove a Script

Select the script in the *Available Scripts* box then click **Remove**. The script is removed from the application however, the original .py text file is not affected.

Edit a Script

| Selections | Description |
|-------------------------|--|
| Add [button] | Adds one or more scripts to the <i>Available Scripts</i> box. The added scripts then become available as options in the <i>Selected Reports</i> section. |
| Edit [button] | Edits the script stored within the application but does not affect the original .py text file. |
| Remove [button] | Removes the script from the <i>Available Scripts</i> box but does not affect original .py text file. |
| Replace [button] | Replaces the contents of the selected script however, the script name remains the same. |

PYTHON REPORTS

Graphic Report

This script is an example of the mic module producing a graph with two curves:

```
1 import mic
2 import numpy as np
3
4 mic.graph( 'My Graph', 'X', 'F(X)' )
5 myx = np.array( [0.1, 0.2, 0.3, 0.4, 0.5, 0.6, 0.7, 0.8, 0.9, 1.0 ]
6 )
7 mic.graph.add( 'X2', myx, myx*myx, marker='o' )
8 mic.graph.add( 'sin(X)', myx, np.sin(myx), marker='^' )
```

The results are:

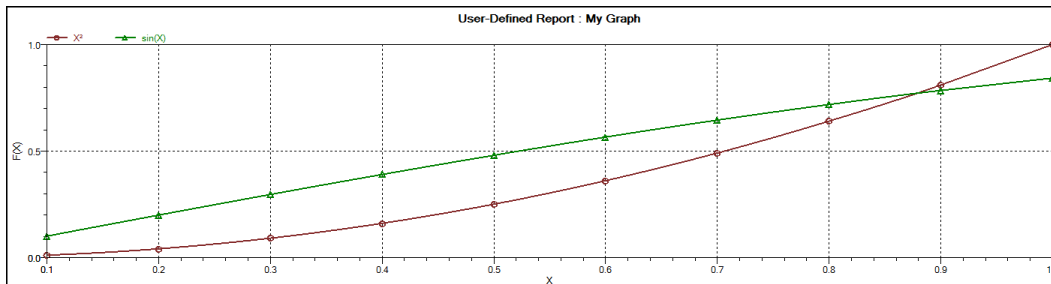

Summary Report

This script produces a summary report with two summaries:

```
1 import mic
2 import numpy as np
3
4 mic.summary( "My Summaries" )
5 mic.summary.add( "Summary A",
6                 ["Label 1:", "Label 2:", "Label 3:"],
7                 ["val1", "val2", "val3"] )
8 mic.summary.add( "Summary B",
9                 ["Label 4:", "Label 5:", "Label 6:"],
10                ["val4", "val5", "val6"] )
```

The result is:

Summary A

Label 1: val1
Label 2: val2
Label 3: val3

Summary B

Label 4: val4
Label 5: val5
Label 6: val6

Tabular Report

If more than one column is required, the call `mic.table` is employed. This script produces a tabular report consisting of two tables.



This script uses the Python package `numpy` and `c`-style formatting of the numerical values.

```
11 import mic
12 import numpy as np
13
14 mic.table( "My Tables" )
15 mic.table.addtable( "My Set A" )
16 mic.table.addcolumn( "X", ["1.0", "2.0", "3.0"] )
17 mic.table.addcolumn( "Y", ["0.5", "1.0", "1.5"] )
18 x1 = 0.2
19 x2 = 0.5
20 x3 = 3.14159/2
21 mic.table.addtable( "My Set B" )
22 mic.table.addcolumn( "X", [ '{:8.3f}'.format(x1),
23                             '{:8.3f}'.format(x2),
24                             '{:8.3f}'.format(x3)] )
25 mic.table.addcolumn( "sin(X)", [ '{:8.3f}'.format(np.sin(x1)),
26                                   '{:8.3f}'.format(np.sin(x2)),
27                                   '{:8.3f}'.format(np.sin(x3))] )
28 mic.table.addcolumn( "cos(X)", [ '{:8.3f}'.format(np.cos(x1)),
29                                   '{:8.3f}'.format(np.cos(x2)),
30                                   '{:8.3f}'.format(np.cos(x3))] )
```

The result is:

| My Set A | |
|-----------------|-----|
| X | Y |
| 1.0 | 0.5 |
| 2.0 | 1.0 |
| 3.0 | 1.5 |

| My Set B | | |
|-----------------|--------|--------|
| X | sin(X) | cos(X) |
| 0.200 | 0.199 | 0.980 |
| 0.500 | 0.479 | 0.878 |
| 1.571 | 1.000 | 0.000 |

ACQUIRE BASIC INFORMATION

This script produces a graph of the primary, repeat, and difference isotherms, and prints summaries of the sample information and the adsorptive properties.

To acquire the adsorption isotherm and other basic information about the sample being edited, the calls `mic_chem.isotherm`, `mic.sample_information`, and `mic.adsorptive_data` are applied.

Note the calls to `mic_chem.isotherm` and `mic.adsorptive_data` above are each returning results as a list with elements of varying return type.

```
1 import mic
2
3 p_primary, q_primary = mic.chem_isotherm('primary')
4 p_repeat, q_repeat = mic.chem_isotherm('repeat')
5 p_difference, q_difference = mic.chem_isotherm('difference')
6 mic.graph('Graphical Report 1', 'Absolute Pressure (mmHg)', 'Quantity Adsorbed (cm3/g STP)')
7 mic.graph.add('Primary', p_primary, q_primary)
8 mic.graph.add('Repeat', p_repeat, q_repeat)
9 mic.graph.add('Difference', p_difference, q_difference)
10
11 mic.summary("Sample Information")
12 mic.summary.add( "Sample Information",
13                 [ "Ambient free space:",
14                   "Analysis free space:",
15                   "Sample mass:",
16                   "Description:",
17                   "Analysis temperature:",
18                   "Sample density:" ],
19                 [ '{:8.3f}'.format(mic.sample_information('ambient
20 freespace')) + ' cm3',
21                   '{:8.3f}'.format(mic.sample_information('ana-
22 lysis freespace')) + ' cm3',
23                   '{:8.3f}'.format(mic.sample_information('sample
24 mass')) + ' g',
```

```

22         mic.sample_information('sample description'),
23         '{:8.3f}'.format(mic.sample_information('ana-
analysis temperature')) + ' K',
24         '{:8.3f}'.format(mic.sample_information('sample
density')) + ' g/cm3' ] )
25
26 csa, hsd, dcf, mol_weight, analysis_gas = mic.adsorptive_data()
27
28 mic.summary.add( "Adsorptive Data",
29                 [ "Cross sectional area:",
30                   "Hard sphere diameter:",
31                   "Density conversion factor:",
32                   "Molecular weight:",
33                   "Analysis gas:" ],
34                 [ '{:8.3f}'.format(csa) + ' nm2',
35                   '{:8.3f}'.format(hsd) + ' Å',
36                   '{:8.3f}'.format(dcf),
37                   '{:8.3f}'.format(mol_weight),
38                   analysis_gas ] )

```

ENABLE THE USE OF OVERLAY DATA

1. On the *Report Options* tab, click **Overlays**.
2. On the *Plot Overlay Sample Selection* window, to move a file from the *Available Files* list box to the *Selected Files* list box, either double-click a file name in the *Available Files* list box or click one or more files in the *Available Files* list box then click **Add**.

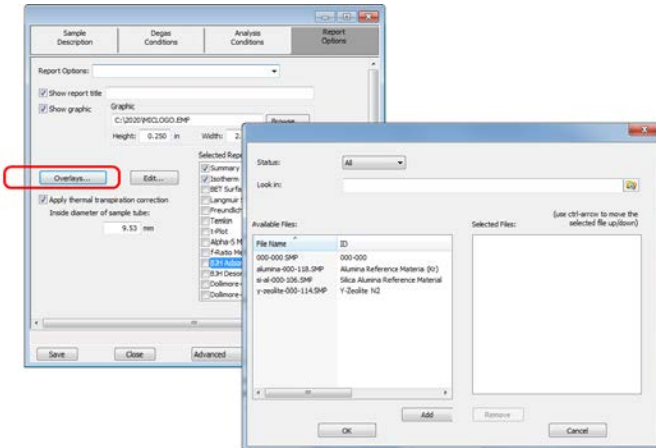

3. Click **OK**.
4. On the *Report Options* tab, highlight *Advanced* in the *Selected Reports* list box.
5. Click **Edit**.
6. Select the *Overlay samples* checkbox to the right of the selected report.
7. Click **OK**.
8. Run the script using the instructions found in [Scripts on page A - 3](#).

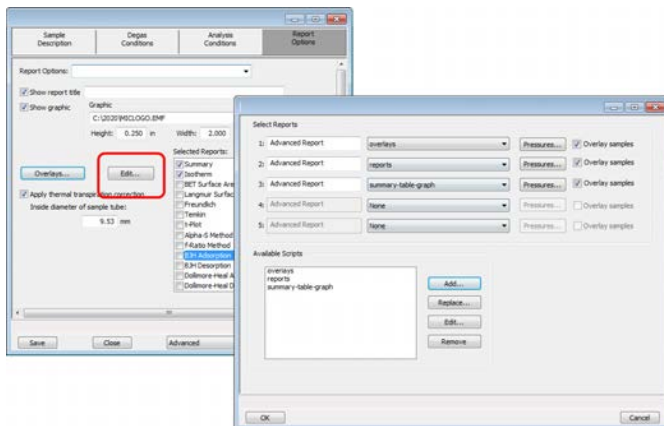

MICMODULE PYTHON CALLS

TABLES

Available Mic Python calls for tables:

- Create a new tabular report
- Add a column
- Add a table

Add a Table

This script adds a table to the last created tabular report:

```

1 mic.table.addtable( name )
2
3 Keyword arguments:
4
5     name --- the table name

```

Add a Column

This script adds a column to the last created table:

```

1 mic.table.addcolumn(header, values, align='r'):
2
3 Keyword arguments:
4
5     header --- column header; must be a string (or convertible)
6     values --- column values; must be a list of strings (or convertible)
7     align --- column alignment; 'r', 'l', 'c' for right, left, and
    center justified

```

Create a New Tabular Report

```
1 mic.table( title='User Table' )
2
3 Keyword arguments:
4
5     title --- the tabular report title (default = 'User Table')
```

SUMMARY REPORTS

Add a Summary Section

This script adds a summary section to the last created summary report:

```
1 mic.summary.add(name, labels, values):
2
3 Keyword arguments:
4
5     name    --- summary section name
6     labels  --- column of labels; must be a list of strings
7              (or convertible) and the same length as values
8     values  --- column of values; must be a list of strings
9              (or convertible) and the same length as labels
```

Create a New Summary Report

```
1 mic.summary( title='User Summary' )
2
3 Keyword arguments:
4
5     title  --- the summary title
```

GRAPHIC REPORTS

Add a Curve

This script adds a curve to the last created graphical report:

```

1 mic.graph.add(name, x, y, yyaxis=False, color=None, linestyle='-',
2               marker='a', graphtype='both', interpolation='akima'):
3
4 Keyword arguments:
5
6 name      --- the curve name
7 x         --- list of x values; must be a list of floats
8           (or convertible) and the same length as y
9 y         --- list of y values; must be a list of floats
10          (or convertible) and the same length as x
11 yyaxis   --- place this curve on the yy-axis if True
12           otherwise place on the y-axis (default = False)
13 color    --- RGB color as an HTML hex string (e.g., '#4169e1')
14           or a three-element list or tuple (e.g.,
15 [65,105,225]);
16           if None, color is automatically selected (default =
17 None)
18 linestyle --- line style; (default = '-')
19           '-'      : solid
20           '--'     : dash
21           '.'      : dot
22           '-.'     : dash dot
23           '-..'    : dash dot dot
24 marker    --- marker shape; (default = 'a')
25           '+'      : plus
26           'o' or '0' : circle
27           'x'      : cross
28           '^'      : up triangle

```

```

27         'v'           : down triangle
28         's'           : square
29         'd'           : diamond
30         '8'           : hourglass
31         '~'           : horizontal hourglass
32         '' or None    : no marker
33         'a'           : automatically selected
34     graphtype --- graph type; (default = 'both')
35         'curve' or 'c' : curve
36         'points' or 'p' : points
37         'both' or 'b' : curve-and-points
38         'hist' or 'h' : histogram
39     interpolation -- linear or akima spline interpolation
    (default='akima')
40         'akima' use akima spline
41         'linear' use linear interpolation
    
```

Add a Curve Using the Second Y-Axis

This script adds a curve to the last created graphical report using the second y-axis:

```

1 mic.graph.addyy(name, xx, yy):
2
3 Add a curve to the last created graphical report using the second
4 y-axis. The arguments to this call are the same as to mic.-
  graph.add.
    
```

Create a New Graphical Report

```
1 mic.graph(title='User Graph', xlabel='X axis', ylabel='Y axis',
2           ylabel='YY axis',
3           xlinear=True, ylinear=True, yylinear=True,
4           xinvert=False, yinvert=False, yyinvert=False,
5           xrange=None, yrange=None, yrange=None, xbars_id=''):
6
7 Keyword arguments:
8
9 title    --- the graphical report title (default = 'User Graph')
10 xlabel  --- x-axis label (default = 'X axis')
11 ylabel  --- y-axis label (default = 'Y axis')
12 ylabel  --- yy-axis label (default = 'YY axis')
13 xlinear  --- x-axis linear scale; if false, use log scale
14          (default = True)
15 ylinear  --- y-axis linear scale; if false, use log scale
16          (default = True)
17 yylinear --- yy-axis linear scale; if false, use log scale
18          (default = True)
19 xinvert  --- Invert x-axis if true (default = False)
20 yinvert  --- Invert y-axis if true (default = False)
21 yyinvert --- Invert yy-axis if true (default = False)
22 xrange   --- None, or two values giving the min and max
23          range of the axis.
24 yrange   --- None, or two values giving the min and max
25          range of the axis.
26 yyrange  --- None, or two values giving the min and max
27          range of the axis.
28 xbars_id --- None, or the id of an xbar control created
29          via the mic.control() object
```

GET EXPERIMENT INFORMATION

```
1 mic.dyn_chem_experiment(exp_num, sec_num=0, item=''):
2
3   Get data associated with the indexed experiment
4
5   Keyword arguments:
6
7   exp_num    --- The index of the experiment to acquire
8               information for. Indexing begins at 1
9
10  sec_num    --- If zero, the primary experiment data is
11               returned.
12               If greater than zero, returns associated sec-
13               ondary
14               experiment if any (typically these are mass
15               specs).
16
17  item       --- the specific experiment property to return
18               information on. If '' or None, then return
19               the whole experiment dictionary
20
21  Usage:
22
23  exp = mic.dyn_chem_experiment(exp_num = 1)
24  ms1 = mic.dyn_chem_experiment(exp_num = 1, sec_num = 1)
25  expid = mic.dyn_chem_experiment(exp_num = 1, item = 'id')
26  temp = mic.dyn_chem_experiment(exp_num = 1, item = 'tem-
27         perature')
```

`mic.dyn_chem_experiment_all():`

Return a dictionary of all experiments. The key is the experiment

```
28     number, the value is a dictionary with keys from 0 (primary exper-
29     iment
30     data) through n where n is the number of secondary experiments
    (e.g.,
    mass spec data).
```

GET SAMPLE INFORMATION ITEM

```
1 mic.sample_information( item, sample_number = 0 ):
2
3 Keyword arguments:
4
5 item          --- string identifying the item to be returned.
6                For example; 'sample mass', or 'sample descrip-
7                tion'
8                The default is an empty string for which the
9                return value is a list of all available keywords
10
11 sample_number --- Sample to retrieve
12                0          : current sample file (default)
13                1 through 8 : corresponding overlay sample file
14
15 Usage:
16
17 all_keywords = sample_information()
18 mass        = sample_information('sample mass')
19 mass        = sample_information('sample mass',0)
```

GET IMPORTED PORE DATA

```
1 mic.imported_pore_data(import_number=1):
2
3 Get imported pore data.
4
5 Keyword arguments:
6
7     import_number --- the import number (1 through 8)
8
9 Usage:
10
11     porew, incvol, desc = mic.imported_pore_data(1)
12
13     porew --- array of pore dimension boundaries (angstroms);
14             empty-array if unavailable.
15     incvol --- array of incremental pore volumes (cm3/g);
16             empty-array if unavailable.
17     desc   --- Name of data set; empty-string if unavailable.
```

GET METAL COMPOSITION FOR CHEMISORPTION

```

1 mic.metal_composition(metal='', metal_property='', sample_
  number=0):
2
3 Get information about the active metals in this sample
4
5 Keyword arguments:
6
7     metal          --- the metal to return information about
8                     if '' or None, then return a list of the
9                     active metals
10
11    metal_property --- the specific property to return information
12    on
13                    if '' or None, then return all the prop-
14    erties
15                    for the specified metal (requires metal to
16    be
17                    specified)
18
19    sample_number --- Identifier for the metal data to retrieve
20
21    0                : current sample file (default)
22    1 through 8     : corresponding overlay sample
23    file
24
25 Usage:
26
27     metal_list = mic.metal_composition()
28     copper_prop = mic.metal_composition('copper')
29     copper_perc = mic.metal_composition('copper',
30                                       'percent of sample mass')
31
32 In the above first usage case, the list of active metals is
  
```

```
returned.  
28 In the above second usage case, a python dictionary type  
29 is returned which includes all the properties of the metal  
30 available and their corresponding values. The last case returns  
31 a single value (int, float, or string) for the specified property.  
32  
33 The metal_property keywords which one can use are  
34  
35     atomic weight  
36     oxygen atoms  
37     density  
38     percent of sample mass  
39     metal atoms  
40     cross sectional area  
41     percent reduced  
42     stoichiometry GASNAME  
43  
44 where in the last keyword one substitutes the desired gas name to  
45 obtain its stoichiometry factor. One can also make the call  
46 metal_composition(metalname) without any metal_property keyword  
47 provided to see the whole dictionary of keywords and values.
```

B ATOMIC WEIGHTS AND CROSS-SECTIONAL AREAS

Atomic Weights and Cross-sectional Areas for Selected Metals

| Metal | Symbol | Atomic Weight (g/mol) | Cross-sectional Area (nm²) | Density (g/mL) |
|--------------|---------------|------------------------------|--|-----------------------|
| chromium | Cr | 51.996 | 0.0635 | 7.19 |
| cobalt | Co | 58.933 | 0.0662 | 8.9 |
| copper | Cu | 63.54 | 0.0680 | 8.96 |
| gold | Au | 196.967 | 0.08696 | 18.9 |
| hafnium | Hf | 178.490 | 0.0862 | 13.3 |
| iridium | Ir | 192.220 | 0.0769 | 22.4 |
| iron | Fe | 55.847 | 0.0613 | 7.89 |
| manganese | Mn | 54.938 | 0.0714 | 7.43 |
| molybdenum | Mo | 95.940 | 0.0730 | 10.22 |
| nickel | Ni | 58.710 | 0.0649 | 8.9 |
| niobium | Nb | 92.906 | 0.0806 | 8.57 |
| osmium | Os | 190.220 | 0.0629 | 22.6 |
| palladium | Pd | 106.400 | 0.0787 | 12.02 |
| platinum | Pt | 195.090 | 0.0800 | 21.45 |
| rhenium | Re | 186.2 | 0.0649 | 21.02 |
| rhodium | Rh | 102.905 | 0.0752 | 12.1 |
| ruthenium | Ru | 101.070 | 0.0613 | 12.4 |
| silver | Ag | 107.868 | 0.0869 | 10.5 |
| tantalum | Ta | 180.947 | 0.0800 | 16.6 |
| thorium | Th | 232.038 | 0.1350 | 11.7 |
| tin | Sn | 118.710 | 0.1082 | 4.54 |
| tungsten | W | 183.850 | 0.0741 | 19.3 |
| vanadium | V | 50.942 | 0.0680 | 6.11 |
| zirconium | Zr | 91.220 | 0.0877 | 6.51 |

**This page
intentionally
left blank**

C AUXILIARY INPUTS AND OUTPUTS

File > New Sample [or Open] > Analysis Conditions tab

Analog and digital signals can be connected to the analyzer. Two industry standard *D* shell connectors are available on the analyzer. A shielded cable with male pins must be used for any auxiliary signal connected to the analyzer. The analog connector uses a 15 pin body; the digital connector uses a 25 pin body. The cable shield must connect to a metal shell *D* connector housing.

Analog inputs are enabled by marking one or both check boxes on the *Insert Experiment* window.

Click **Insert** then select *Experiment*. After an auxiliary input is enabled, it remains enabled for the duration of the experiment. Because an analysis can be comprised of many experiments, an input can be disabled or enabled at various points in the analysis, as determined by the selection on the *New Experiment* windows.

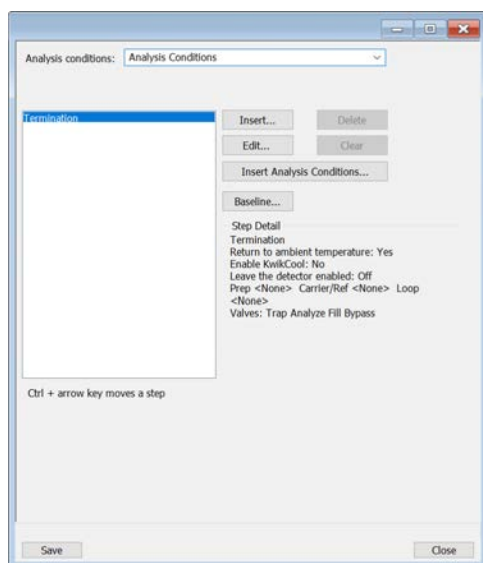

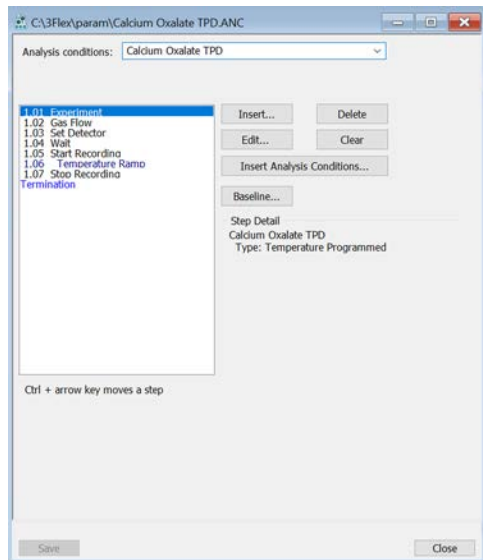

Digital inputs are controlled by inserting a *Wait* step in the analysis. On the *Wait* window, select *Wait for digital input number*. Specify 1 or 2 to indicate the input signal. Enter a number of minutes to wait; if the signal is not received before that amount of time elapses, the analysis continues without the input.

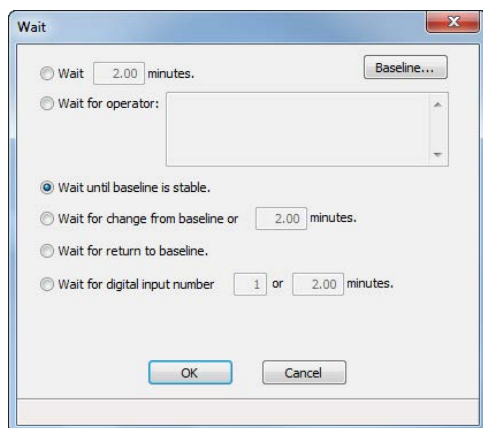

Analog and digital outputs are enabled by marking the applicable check box(es) on the *Outputs* window. The *Outputs* window is available when setting the initial conditions for an experiment (by clicking the **Outputs** button on the *New Experiment* window), or at many other points in the analysis (by inserting a *Set Outputs* step in the experiment). The state of the auxiliary outputs can be changed frequently throughout the analysis.

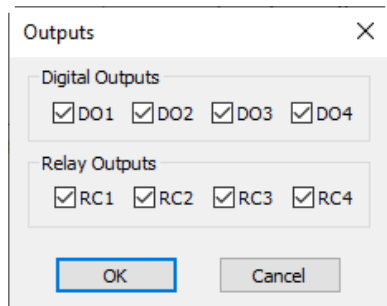

The state of the auxiliary inputs and outputs is displayed on the analyzer schematic. Auxiliary signals can be incorporated in reports (overlaid over other data in graphs), in the *Results* view of the *Analysis* window (during analysis) and in the Peak Editor.

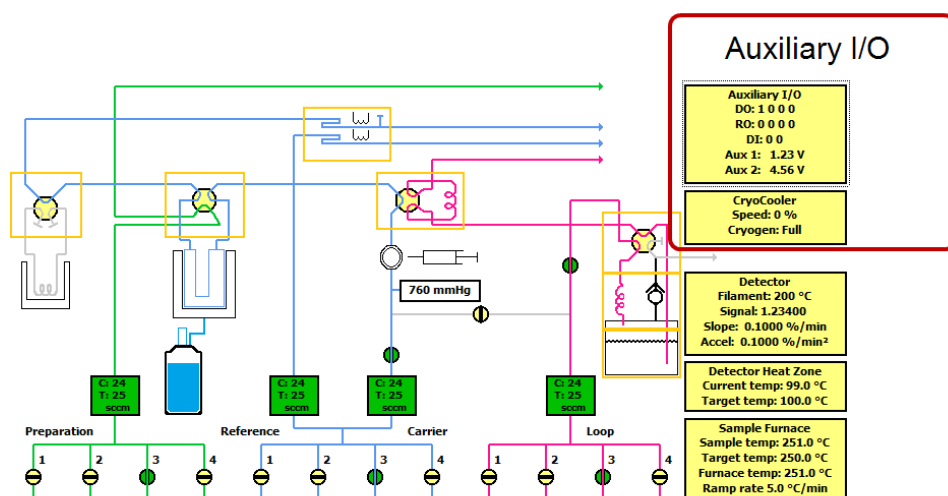

In the *Auxiliary Status Display* on the analyzer schematic, a zero or a one is displayed to show the state of each digital output (DO), relay output (RO), and digital input (DI). See [Digital on page C - 5](#).

The voltage is displayed for each analog input (AUX 1 and AUX 2).

ANALOG

The 15 pin analog connector provides two output signals and two input signals.

OUTPUT SIGNALS:

- The TCD signal (could be as high as 12 volts —positive or negative).
- The sample temperature signal, which is a buffered voltage from the sample thermocouple. The voltage ranges from -0.365 V at $-40\text{ }^{\circ}\text{C}$, 0 at $0\text{ }^{\circ}\text{C}$, to 10.88 V at $1110\text{ }^{\circ}\text{C}$. The signal follows the type-K thermocouple nonlinear characteristic.

The signals are available at these pins:

TCD (+) 7

TCD (–) 5

Temp (+) 8

Temp (–) 6

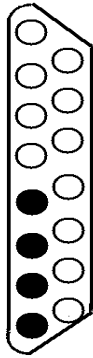

INPUT SIGNALS:

The inputs are available for connection to other detectors, such as a mass spectrometer. The voltage range is -15 to 15 volts. The analyzer application can record these signals at the same time as it records TCD and sample thermocouple data.

The signals connect to these pins:

Auxiliary input 1 (+) 4

Auxiliary input 1 (–) 3

Auxiliary input 2 (+) 2

Auxiliary input 2 (–) 1

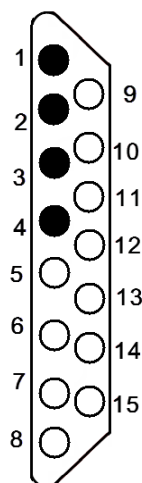

All other pins in the 15 pin connector are floating (not connected). Connect the metal shell of the connector to the chassis ground and cable shield to maintain shielding of the signals.

DIGITAL

The 25 pin digital connector provides floating signals to control and monitor external hardware — such as auxiliary detectors or chart recorders.

The outputs consist of four sets of latching relay contacts and four opto-coupled photo transistors. The inputs are two optically isolated photo couplers.

The analyzer application sets these as logic 1 or logic 0 — as defined by the analysis step. They are displayed on the analyzer schematic.

A logic 1 causes the relay to connect the *common* contact to the *normally open* contact. The relay will retain this condition even when power to the analyzer is disconnected. A logic 0 causes the relay to connect the *common* contact to the *normally closed* contact.

A logic 1 to the opto-coupled outputs causes the NPN photo transistor to be turned on. A logic 0 turns the NPN photo transistor off.

The two opto-coupled inputs are read by the analyzer as logic 1 (when current flows through the opto-coupler photo diodes) or logic 0 (when no current is flowing).

ELECTRICAL SPECIFICATIONS

| | |
|-----------------------------|---|
| Relays | Maximum voltage = 250V~, 48 VDC Maximum switching current = 4A at 250V~; 3A at 30 VDC Maximum switching current = 100 mA at 100 VDC |
| Opto-coupled outputs | Maximum voltage: VCE = 70 VDC Maximum reverse voltage, VCE = 7 VDC Maximum current = 10 mA |
| Opto-coupled inputs | Maximum reverse voltage = 3 v Nominal forward voltage 1.3 v at 10 Minimum current required to be recognized by the analyzer = 1 mA |

Digital Connector Pin Designations

| Pin | Type | Function |
|-----|---------------|-----------------|
| 1 | Relay 1 | normally closed |
| 2 | Relay 1 | common |
| 3 | Relay 1 | normally open |
| 4 | Relay 2 | normally closed |
| 5 | Relay 2 | common |
| 6 | Relay 2 | normally open |
| 7 | Relay 3 | normally closed |
| 8 | Relay 3 | common |
| 9 | Relay 3 | normally open |
| 10 | Relay 4 | normally closed |
| 11 | Relay 4 | common |
| 12 | Relay 4 | normally open |
| 13 | Not Used | Not used |
| 14 | Opto output 1 | collector |
| 15 | Opto output 1 | emitter |
| 16 | Opto output 2 | collector |
| 17 | Opto output 2 | emitter |
| 18 | Opto output 3 | collector |
| 19 | Opto output 3 | emitter |

Digital Connector Pin Designations (continued)

| Pin | Type | Function |
|------------|---------------|-----------------|
| 20 | Opto output 4 | collector |
| 21 | Opto output 4 | emitter |
| 22 | Opto input 1 | anode (+) |
| 23 | Opto input 1 | Cathode (-) |
| 24 | Opto input 2 | anode (+) |
| 25 | Opto input 2 | cathode (-) |

**This page
intentionally
left blank**

D EXPORTED DATA EXAMPLE

Sample Information

```

Sample:      NH3 - heat of desorption - weak sites
Operator:
Submitter:
Mass type:   Entered
Sample mass: 0.0591 g
Density:     1.000 g/cm³
Type of data: Automatically collected
Instrument type: 2920
original instrument type: 2920
Comments:    Heat of Desorption experiment using ammonia.
    
```

Active Metals Table

| Element | Atomic weight | Atomic Cross Sect Area (nm²) | Density (g/cm³) | Percent of Sample weight (%) | | Percent Reduced | MxOy | MxOy |
|----------|---------------|------------------------------|-----------------|------------------------------|--------|-----------------|------|------|
| | | | | X | Y | | | |
| chromium | 51.9960 | 0.0635 | 7.190 | 0.00 | 100.00 | 1 | 0 | |
| | Adsorptive | Stoichiometry | | | | | | |
| | <None> | 1.000 | | | | | | |
| | <None> | 1.000 | | | | | | |
| | <None> | 1.000 | | | | | | |
| | <None> | 1.000 | | | | | | |
| | <None> | 1.000 | | | | | | |
| | <None> | 1.000 | | | | | | |
| | <None> | 1.000 | | | | | | |
| | <None> | 1.000 | | | | | | |
| | <None> | 1.000 | | | | | | |
| cobalt | 58.9330 | 0.0662 | 8.900 | 0.00 | 100.00 | 1 | 0 | |
| | Adsorptive | Stoichiometry | | | | | | |
| | <None> | 1.000 | | | | | | |
| | <None> | 1.000 | | | | | | |
| | <None> | 1.000 | | | | | | |
| | <None> | 1.000 | | | | | | |
| | <None> | 1.000 | | | | | | |
| | <None> | 1.000 | | | | | | |
| | <None> | 1.000 | | | | | | |
| | <None> | 1.000 | | | | | | |
| | <None> | 1.000 | | | | | | |
| copper | 63.5400 | 0.0680 | 8.960 | 0.00 | 100.00 | 1 | 0 | |
| | Adsorptive | Stoichiometry | | | | | | |
| | <None> | 1.000 | | | | | | |
| | <None> | 1.000 | | | | | | |
| | <None> | 1.000 | | | | | | |
| | <None> | 1.000 | | | | | | |
| | <None> | 1.000 | | | | | | |
| | <None> | 1.000 | | | | | | |
| | <None> | 1.000 | | | | | | |
| | <None> | 1.000 | | | | | | |
| | <None> | 1.000 | | | | | | |

| | | | | | | | |
|---------|------------|---------------|--------|------|--------|---|---|
| rhodium | 102.9050 | 0.0752 | 12.410 | 0.00 | 100.00 | 1 | 0 |
| | Adsorptive | Stoichiometry | | | | | |
| | <None> | 1.000 | | | | | |
| | <None> | 1.000 | | | | | |
| | <None> | 1.000 | | | | | |
| | <None> | 1.000 | | | | | |
| | <None> | 1.000 | | | | | |
| | <None> | 1.000 | | | | | |
| | <None> | 1.000 | | | | | |
| | <None> | 1.000 | | | | | |
| | <None> | 1.000 | | | | | |
| | <None> | 1.000 | | | | | |
| | <None> | 1.000 | | | | | |
| | <None> | 1.000 | | | | | |
| | <None> | 1.000 | | | | | |
| | <None> | 1.000 | | | | | |
| | <None> | 1.000 | | | | | |
| | <None> | 1.000 | | | | | |
| | <None> | 1.000 | | | | | |
| silver | 107.8680 | 0.0869 | 10.500 | 0.00 | 100.00 | 1 | 0 |
| | Adsorptive | Stoichiometry | | | | | |
| | <None> | 1.000 | | | | | |
| | <None> | 1.000 | | | | | |
| | <None> | 1.000 | | | | | |
| | <None> | 1.000 | | | | | |
| | <None> | 1.000 | | | | | |
| | <None> | 1.000 | | | | | |
| | <None> | 1.000 | | | | | |
| | <None> | 1.000 | | | | | |
| | <None> | 1.000 | | | | | |
| | <None> | 1.000 | | | | | |
| | <None> | 1.000 | | | | | |
| | <None> | 1.000 | | | | | |
| | <None> | 1.000 | | | | | |
| | <None> | 1.000 | | | | | |
| | <None> | 1.000 | | | | | |
| | <None> | 1.000 | | | | | |

Analysis conditions

Analysis conditions: Analysis Conditions

Baseline options

Stable Baseline
 Slope threshold: 0.010 %/min
 Duration: 5.00 min
 Change from Baseline
 Acceleration threshold: 1.000 %/min²
 Duration: 0.25 min
 Return to Baseline
 Acceleration threshold: 0.100 %/min²
 Duration: 1.00 min

Tasks

| Description | Details |
|-----------------------|---|
| 1.01 Experiment | TPD 10 C/min Prep None Carrier/Ref Helium Loop None Valves: Bypass Analyze Fill Bypass |
| 1.02 Temperature Ramp | Type: Sample RampTemp: 500 °C Rate: 10.0 Time: 0.00 min Cool: No |
| 1.03 Temperature Ramp | Type: Sample RampTemp: 120 °C Rate: 10.0 Time: 0.00 min Cool: Yes |
| 1.04 Change Gas Flows | Prep 10% NH ₃ Carrier/Ref Helium Loop None Valves: Bypass Prepare Fill Bypass |
| 1.05 wait | wait for 30.00 minutes. |
| 1.06 Change Gas Flows | Prep None Carrier/Ref Helium Loop None Valves: Bypass Analyze Fill Bypass |
| 1.07 wait | wait for 60.00 minutes. |
| 1.08 wait | wait until Baseline is stable. |
| 1.09 Start Recording | One measurement every 1.0 seconds |
| 1.10 Temperature Ramp | Type: Sample RampTemp: 500 °C Rate: 10.0 Time: 30.00 min Cool: No |
| 1.11 Stop Recording | Stop Recording |
| 2.01 Experiment | TPD 5 C/min Prep 10% NH ₃ Carrier/Ref Helium Loop None Valves: Bypass Prepare Fill Bypass |
| 2.02 Temperature Ramp | Type: Sample RampTemp: 120 °C Rate: 10.0 Time: 0.00 min Cool: Yes |
| 2.03 wait | wait for 30.00 minutes. |
| 2.04 Change Gas Flows | Prep None Carrier/Ref Helium Loop None Valves: Bypass Analyze Fill Bypass |
| 2.05 wait | wait for 60.00 minutes. |
| 2.06 wait | wait until Baseline is stable. |
| 2.07 Start Recording | One measurement every 1.0 seconds |
| 2.08 Temperature Ramp | Type: Sample RampTemp: 500 °C Rate: 5.0 Time: 30.00 min Cool: No |
| 2.09 Stop Recording | Stop Recording |
| 3.01 Experiment | TPD 20 C/min Prep 10% NH ₃ Carrier/Ref Helium Loop None Valves: Bypass Prepare Fill Bypass |
| 3.02 Temperature Ramp | Type: Sample RampTemp: 120 °C Rate: 10.0 Time: 0.00 min Cool: Yes |
| 3.03 wait | wait for 30.00 minutes. |
| 3.04 Change Gas Flows | Prep None Carrier/Ref Helium Loop None Valves: Bypass Analyze Fill Bypass |
| 3.05 wait | wait for 60.00 minutes. |
| 3.06 wait | wait until Baseline is stable. |
| 3.07 Start Recording | One measurement every 1.0 seconds |
| 3.08 Temperature Ramp | Type: Sample RampTemp: 500 °C Rate: 20.0 Time: 30.00 min Cool: No |
| 3.09 Stop Recording | Stop Recording |
| 4.01 Experiment | TPD 2 C/min Prep 10% NH ₃ Carrier/Ref Helium Loop None Valves: Bypass Prepare Fill Bypass |
| 4.02 Temperature Ramp | Type: Sample RampTemp: 120 °C Rate: 10.0 Time: 0.00 min Cool: Yes |
| 4.03 wait | wait for 30.00 minutes. |
| 4.04 Change Gas Flows | Prep None Carrier/Ref Helium Loop None Valves: Bypass Analyze Fill Bypass |
| 4.05 wait | wait for 60.00 minutes. |
| 4.06 wait | wait until Baseline is stable. |
| 4.07 Start Recording | One measurement every 1.0 seconds |
| 4.08 Temperature Ramp | Type: Sample RampTemp: 500 °C Rate: 2.0 Time: 30.00 min Cool: No |
| 4.09 Stop Recording | Stop Recording |
| 5.01 Experiment | TPD 15 C/min Prep None Carrier/Ref Helium Loop None Valves: Bypass Analyze Fill Bypass |
| 5.02 Temperature Ramp | Type: Sample RampTemp: 120 °C Rate: 10.0 Time: 0.00 min Cool: Yes |
| 5.03 Change Gas Flows | Prep 10% NH ₃ Carrier/Ref Helium Loop None Valves: Bypass Prepare Fill Bypass |
| 5.04 wait | wait for 30.00 minutes. |
| 5.05 Change Gas Flows | Prep None Carrier/Ref Helium Loop None Valves: Bypass Analyze Fill Bypass |

| | | |
|------|------------------|---|
| 5.06 | wait | wait for 60.00 minutes. |
| 5.07 | wait | wait until Baseline is stable. |
| 5.08 | Start Recording | One measurement every 1.0 seconds |
| 5.09 | Temperature Ramp | Type: Sample RampTemp: 500 °C Rate: 15.0 Time: 30.00 min Cool: No |
| 5.10 | Stop Recording | Stop Recording |
| 6.01 | Experiment | TPD 7 C/min Prep 10% NH3 Carrier/Ref Helium Loop None Valves: Bypass Prepare Fill Bypass |
| 6.02 | Temperature Ramp | Type: Sample RampTemp: 120 °C Rate: 10.0 Time: 0.00 min Cool: Yes |
| 6.03 | wait | wait for 30.00 minutes. |
| 6.04 | Change Gas Flows | Prep None Carrier/Ref Helium Loop None Valves: Bypass Analyze Fill Bypass |
| 6.05 | wait | wait for 60.00 minutes. |
| 6.06 | wait | wait until Baseline is stable. |
| 6.07 | Start Recording | One measurement every 1.0 seconds |
| 6.08 | Temperature Ramp | Type: Sample RampTemp: 500 °C Rate: 7.0 Time: 30.00 min Cool: No |
| 6.09 | Stop Recording | Stop Recording |
| 7.01 | Experiment | TPD 30 C/min Prep 10% NH3 Carrier/Ref Helium Loop None Valves: Bypass Prepare Fill Bypass |
| 7.02 | Temperature Ramp | Type: Sample RampTemp: 120 °C Rate: 10.0 Time: 0.00 min Cool: Yes |
| 7.03 | wait | wait for 30.00 minutes. |
| 7.04 | Change Gas Flows | Prep None Carrier/Ref Helium Loop None Valves: Bypass Analyze Fill Bypass |
| 7.05 | wait | wait for 60.00 minutes. |
| 7.06 | wait | wait until Baseline is stable. |
| 7.07 | Start Recording | One measurement every 1.0 seconds |
| 7.08 | Temperature Ramp | Type: Sample RampTemp: 500 °C Rate: 30.0 Time: 30.00 min Cool: No |
| 7.09 | Stop Recording | Stop Recording |
| 8.01 | Experiment | TPD 4 C/min Prep 10% NH3 Carrier/Ref Helium Loop None Valves: Bypass Prepare Fill Bypass |
| 8.02 | Temperature Ramp | Type: Sample RampTemp: 120 °C Rate: 10.0 Time: 0.00 min Cool: Yes |
| 8.03 | wait | wait for 30.00 minutes. |
| 8.04 | Change Gas Flows | Prep None Carrier/Ref Helium Loop None Valves: Bypass Analyze Fill Bypass |
| 8.05 | wait | wait for 60.00 minutes. |
| 8.06 | wait | wait until Baseline is stable. |
| 8.07 | Start Recording | One measurement every 1.0 seconds |
| 8.08 | Temperature Ramp | Type: Sample RampTemp: 500 °C Rate: 4.0 Time: 30.00 min Cool: No |
| 8.09 | Stop Recording | Stop Recording |

Termination Return to Ambient Temperature: Yes Enable kwikCool: No Leave the detector enabled: Off Prep None
 Carrier/Ref None Loop None Valves: Bypass Analyze Fill Bypass

Report Options

Report Options

Report options: Default Report Options
 Report title: Micromeritics Instrument Corporation -- AutoChem II 2920
 Show graphic: No
 Graphic width: 2.000 in
 Graphic height: 0.250 in

Peak Detection/Integration Options

Baseline mode: Best fit baseline
 Minimum peak height: 0.25 %F.S.
 Peak smoothing: 0 points
 Sensitivity: 0.01 %F.S.
 Maximum shoulder ratio: 33%
 Maximum group separation: 33%
 Minimum peak area: 1.0 min.%F.S.
 Baseline slope: 0.1 %F.S./min

Reports

Summary NO
 BET Surface Area NO
 Langmuir Surface Area NO
 Total Pore Volume NO
 Pulse Chemisorption NO
 First Order Kinetics YES
 Loop Calibration NO
 TCD Signal vs. Time NO
 TCD Signal vs. Time NO
 TCD Signal vs. Temperature NO
 TCD Signal vs. Temperature YES
 TCD Concentration vs. Temperature NO
 Input Signal 1 vs. Time NO
 Input Signal 1 vs. Temperature NO
 Input Signal 2 vs. Time NO
 Input Signal 2 vs. Temperature NO
 TCD Signal and Concentration vs. Time NO
 Advanced Reports NO
 Options Report NO
 Sample Log NO

E GAS CHARTS

RELATIVE THERMAL CONDUCTIVITY OF GASES

| Name | Chemical Formula | Conductivity (Relative to Air) |
|------------------|--|--------------------------------|
| Air | | 1.00 |
| Ammonia | NH ₃ | 0.92 |
| Argon | Ar | 0.68 |
| Butane | C ₄ H ₁₀ | 0.60 |
| Carbon Dioxide | CO ₂ | 0.62 |
| Carbon Monoxide | CO | 0.97 |
| Ethane | C ₂ H ₆ | 0.79 |
| Helium | He | 5.84 |
| Hydrogen | H ₂ | 7.07 |
| Krypton | Kr | 0.37 |
| Methane | CH ₄ | 1.29 |
| Neon | Ne | 1.87 |
| Nitric Oxide | NO | 0.99 |
| Nitrogen | N ₂ | 1.00 |
| Nitrogen Dioxide | NO ₂ or N ₂ O ₄ | 1.51 |
| Nitrous Oxide | N ₂ O | 0.65 |
| Oxygen | O ₂ | 1.02 |
| Sulfur Dioxide | SO ₂ | 0.38 |
| Water Vapor | H ₂ O | 0.67 |

TYPICAL GASES USED

| Flow Rate of 50 cm ³ /min | | | | |
|--|---|------------------------------|------------------------------|--|
| Test | Preparation Gas | Carrier Gas | Loop Gas | Other |
| TPR Experiment | Argon | 10% H ₂ in Argon | N/A | |
| Calibration | N/A | | Argon | TCD Level Calibration |
| TPD Ammonia | Helium or 15% NH ₃ in Helium | Helium | N/A | |
| Calibration | N/A | | NH ₃ in Helium | TCD Level Calibration |
| TPD Pyridine | Helium | Helium | Helium | Pyridine in vapor generator |
| Calibration | N/A | | | User-defined Pyridine in vapor generator |
| TPD Hydrogen | 10% H ₂ in Argon | Argon | N/A | Calibration |
| Calibration | N/A | | 10% H ₂ in Argon | TCD Level Calibration |
| TPD Oxygen | 10% O ₂ in Helium | Helium | N/A | |
| Calibration | N/A | | 10% O ₂ in Helium | TCD Level Calibration |
| TPO Experiment | Helium | 10% O ₂ in Helium | N/A | |
| Calibration | N/A | | Helium | TCD Level Calibration |
| H₂ Pulse Chemisorption | 10% H ₂ in Argon | Argon | 10% H ₂ in Argon | |
| CO Pulse Chemisorption | | Helium | 10% CO in Helium | |
| Calibration | Not Required | | | |
| BET Surface Area | Helium | 30% N ₂ in Helium | N/A | |
| Calibration | N/A | | | User-defined manual injections of N ₂ (0.5, 1.0, 1.5, and 2.0 cm ³) |

GAS CONVERSION CONSTANTS

Dynamic analysis uses a Mass Flow Controller (MFC) to control the flow of gases. The MFC requires a conversion constant for each gas or gas mixture to compensate for variations in gas flows resulting from variations in the properties of gases. A default gas table containing MFC conversion constants is included on the *Options* menu. The following table provides a more complete list of gases and their conversion constants.

Gas Conversion Constants for the MFC

| Gas | Symbol | MFC Conversion Constant (H ₂ = 1.000) |
|-----------------------|--------------------------------|---|
| Acetylene | C ₂ H ₂ | 0.6535 |
| Air (mixture) | | 0.9901 |
| Allene | C ₃ H ₄ | 0.4752 |
| Ammonia | NH ₃ | 0.7822 |
| Argon | Ar | 1.3861 |
| Arsine | AsH ₃ | 0.7525 |
| Boron Trichloride | BCl ₃ | 0.4356 |
| Boron Trifluoride | BF ₃ | 0.5743 |
| Bromine Pentafluoride | BrF ₅ | 0.2871 |
| Bromine Trifluoride | BrF ₃ | 0.4356 |
| Butane | C ₄ H ₁₀ | 0.2871 |
| Butene | C ₄ H ₈ | 0.3267 |
| Carbon Dioxide | CO ₂ | 0.7723 |
| Carbon Monoxide | CO | 0.9802 |
| Carbon Tetrachloride | CCl ₄ | 0.3465 |
| Carbon Tetrafluoride | CF ₄ | 0.4752 |
| Carbonyl Fluoride | COF ₂ | 0.2673 |
| Carbonyl Sulfide | COS | 0.6733 |
| Chlorine | Cl ₂ | 0.8218 |
| Chloroform | CHCl ₃ | 0.4356 |
| Chlorine Trifluoride | ClF ₃ | 0.4257 |

Gas Conversion Constants for the MFC (continued)

| Gas | Symbol | MFC Conversion Constant (H ₂ = 1.000) |
|----------------|--|---|
| Cyanogen | C ₂ N ₂ | 0.4950 |
| Cyclopropane | C ₃ H ₆ | 0.5050 |
| Deuterium | D ₂ | 0.9901 |
| Diborane | B ₂ H ₆ | 0.5446 |
| Dichlorosilane | SiH ₂ Cl ₂ | 0.4356 |
| Dimethylamine | (CH ₃) ₂ NH | 0.6634 |
| Dimethylether | (CH ₃) ₂ O | 0.5842 |
| Ethane | C ₂ H ₆ | 0.5446 |
| Ethyl Chloride | C ₂ H ₅ Cl | 0.2871 |
| Ethylene | C ₂ H ₄ | 0.6139 |
| Ethylene Oxide | C ₂ H ₄ O | 0.5842 |
| Fluorine | F ₂ | 0.9208 |
| Fluroform | CHF ₃ | 0.5644 |
| Freon 11 | CCl ₃ F | 0.3762 |
| Freon 12 | CCl ₃ F ₂ | 0.3861 |
| Freon 13 | CClF ₃ | 0.4257 |
| Freon 13 B1 | CBrF ₃ | 0.4059 |
| Freon 14 | CF ₄ | 0.4703 |
| Freon 21 | CHCl ₂ F | 0.4554 |
| Freon 22 | CHClF ₂ | 0.5050 |
| Freon 23 | CHF ₃ | 0.5644 |
| Freon 113 | CCl ₂ F-CClF ₂ | 0.2277 |
| Freon 114 | CCl ₂ F ₄ -CClF ₂ | 0.2554 |
| Freon 115 | CClF ₂ -CF ₃ | 0.2713 |

Gas Conversion Constants for the MFC (continued)

| Gas | Symbol | MFC Conversion Constant (H ₂ = 1.000) |
|-------------------------|----------------------------------|---|
| Freon 116 | CF ₃ -CF ₃ | 0.2277 |
| Germane | GeH ₄ | 0.6436 |
| Helium | He | 1.3762 |
| Hexamethyldisizane | HMDS | 0.1386 |
| Hydrogen | H ₂ | 1.0000 |
| Hydrogen Bromide | HBr | 0.9703 |
| Hydrogen Chloride (Dry) | HCl | 0.9802 |
| Hydrogen Fluoride | HF | 0.9901 |
| Hydrogen Iodide | HI | 0.9505 |
| Hydrogen Selenide | H ₂ Se | 0.8317 |
| Hydrogen Sulfide | H ₂ S | 0.8416 |
| Isobutane | C ₄ H ₁₀ | 0.3069 |
| Isobutylene | C ₄ H ₈ | 0.3366 |
| Krypton | Kr | 1.3762 |
| Methane | CH ₄ | 0.8020 |
| Methylamine | CH ₃ NH ₂ | 0.5644 |
| Methyl Bromide | CH ₃ Br | 0.6436 |
| Methyl Chloride | CH ₃ Cl | 0.6832 |
| Methyl Fluoride | CH ₃ F | 0.7525 |
| Methyl Mercaptan | CH ₄ S | 0.5842 |
| Neon | Ne | 1.3861 |
| Nitric Oxide | NO | 0.9901 |
| Nitrogen | N ₂ | 0.9950 |
| Nitrogen Dioxide | NO ₂ | 0.7525 |

Gas Conversion Constants for the MFC (continued)

| Gas | Symbol | MFC Conversion Constant (H ₂ = 1.000) |
|---------------------------|-----------------------------------|---|
| Nitrogen Trioxide | N ₂ O ₃ | 0.4356 |
| Nitrogen Trifluoride | NF ₃ | 0.5446 |
| Nitrous Oxide | N ₂ O | 0.7426 |
| Oxygen | O ₂ | 0.9802 |
| Ozone | O ₃ | 0.7327 |
| Pentaborane | B ₅ Hg | 0.2871 |
| n Pentane | C ₅ H ₁₂ | 0.2376 |
| Perchloryl Fluoride | ClO ₃ F | 0.4455 |
| Phosgene | COCl ₂ | 0.5050 |
| Phosphine | PH ₃ | 0.7822 |
| Phosphorous Pentafluoride | PF ₅ | 0.3465 |
| Propane | C ₃ H ₈ | 0.3861 |
| Propylene (Propene) | C ₃ H ₆ | 0.4653 |
| Silane | SiH ₄ | 0.6733 |
| Silicon Tetrachloride | SiCl ₄ | 0.3168 |
| Silicon Tetrafluoride | SiF ₄ | 0.3960 |
| Sulfur Dioxide | SO ₂ | 0.7228 |
| Sulfur Hexafluoride | SF ₆ | 0.2970 |
| Trichlorosilane | Cl ₃ HSi | 0.3267 |
| Trimethylamine | (CH ₃) ₃ N | 0.3168 |
| Tungsten Hexafluoride | WF ₆ | 0.2871 |
| Uranium Hexafluoride | UF ₆ | 0.2178 |
| Vinyl Bromide | C ₂ H ₃ Br | 0.5248 |
| Vinyl Chloride | C ₂ H ₃ Cl | 0.5347 |
| Vinyl Fluoride | C ₂ H ₃ F | 0.5743 |

Gas Conversion Constants for the MFC (continued)

| Gas | Symbol | MFC Conversion Constant (H₂ = 1.000) |
|------------|---------------|--|
| Xenon | Xe | 1.3762 |

**This page
intentionally
left blank**

F PEAK DETECTION / INTEGRATION OPTIONS



This section applies only to dynamic analysis samples.

File Open > [.RPO file] > [Integration button]

Or, select the **Integration** button while in the Peak Editor.

Peak detection parameters can be customized using the **Integration** button on the *Report Options* window or the **Integration** button on the Peak Editor window. Peak detection options can be customized while creating the sample file or after analysis. For Loop calibrations, peaks are found using events that occurred during the analysis — such as the time an injection started — instead of peak detection options.

Peak Detection/Integration Options

Standard Settings

Baseline mode: Best fit baseline
 Snap to baseline

Minimum peak height: %F.S.

Peak smoothing: points

Number of points for smoothing. If peak smoothing value is 0, automatic selection is enabled (1% of data points). Its purpose is identifying peak edges; it does not affect peak height or area.

Advanced Settings

Sensitivity: %F.S.

Maximum shoulder ratio: %

Maximum group separation: %

Minimum peak area: %F.S.·min

Maximum baseline slope: %F.S./min

OK Cancel

Peak Detection/Integration Options

| Selection | Description |
|---|--|
| Standard Settings [group box] | <ul style="list-style-type: none"> Baseline mode The Baseline Mode affects how the <i>Find All Peaks</i> function works. |

Peak Detection/Integration Options (continued)

| Selection | Description |
|---|---|
| | <p>If <i>Best Fit Baseline</i> is selected, the bottom of the peaks is placed in the baseline that best describes the signal outside the range of the peaks. This assumes a linear baseline between the beginning and the end of the peak.</p> <p>If <i>Snap to Signal</i> is selected, the bottom of the peaks is moved to the signal recorded, not the best fit baseline between the peaks.</p> <ul style="list-style-type: none"> <p>■ Minimum peak height</p> <p>Sets the minimum height for peaks to be identified and included in the peak table. This value is expressed in terms of the trace's Y-axis units. Use a value of 0 (zero) to include all peaks.</p> <p>■ Peak smoothing</p> <p>Smoothing allows the application to average the points before using them, so that noise spikes are ignored. Specify the number of points to average into a single value during the peak picking process.</p> <p>The smoothing parameter can be turned off by setting the value at 1 or 0 (zero). A setting of 1 disables smoothing, and the peak edges are interpolated to the best X-axis value. A setting of 0 also disables smoothing, but the peak edges (the points where the peak begins and ends) are not interpolated. Instead, the nearest data point is used as the peak edge.</p> |
| <p>Advanced Settings [group box]</p> | <ul style="list-style-type: none"> <p>■ Sensitivity</p> <p>Sensitivity sets the noise rejection level for identifying the peaks in a trace. Use a value from -100 to 100%. For example, a sensitivity level of 5% means that 5% of all local maxima in the trace are greater than the noise and are, therefore to be considered as peaks. A value of 100% identifies all local maxima (or minima for traces with transmission Y units) as peaks. One possible exception to note is the combination of other rejection parameters (such as <i>Minimum Peak Area and Minimum Peak Height</i>) which can reject peaks even when the sensitivity is set to 100%.</p> <p>The sensitivity can also be set to negative values to define a specific noise level (in Y units) for peak rejection. For example, a sensitivity setting of - 2.5% sets the noise rejection to 2.5 V. This means that</p> |

Peak Detection/Integration Options (continued)

| Selection | Description |
|-----------|---|
| | <p>maxima with an amplitude of 2.5 V or less will be considered as baseline noise instead of as peaks. (As opposed to the <i>Minimum Peak Height</i> rejection parameter which eliminates refined peaks by using their height above the baseline.)</p> <p>A setting of 0 (zero) automatically sets a default noise level for the trace.</p> <ul style="list-style-type: none"> <p>■ Maximum shoulder ratio</p> <p>There can also be shoulder peaks (also called combination peaks) within a group. See Maximum group separation. on the next page for a description of peak groups. Shoulders are usually small peaks that are overlapped on the front or the tail of a larger peak. These peaks can also be called leaders and followers, respectively. As with baseline groups, the areas of these peaks can be calculated incorrectly. If the larger parent peak has a long tail with a much smaller peak riding on it, most of the area under the trace belongs to the parent peak. However, if the area of these peaks was determined using baseline grouping, the smaller peak would be calculated by using vertical drop lines at the edges. This would give the parent peak too little area, and the rider peak too much.</p> <p>The application can detect these shoulder peaks. The areas of shoulder peaks are calculated by drawing a skimmed baseline from the leading edge to the trailing edge. Either an exponential or a straight skim line can be used. The skim type is specified by a secondary method parameter (see Methods on page 2 - 23) and the default is exponential skimming. The remaining area between the shoulder peak baseline and the group baseline is considered to be part of the parent peak.</p> <p>The <i>Max Shoulder Ratio</i> parameter is used to specify whether the peaks that are overlapped in the front or the tail of much larger peaks should be identified as shoulder peaks. To use shoulder peak detection, use a nonzero value for the <i>Max Shoulder Ratio</i> parameter. After a baseline group has been identified, the application looks for peaks within the group that satisfy the following shoulder peak criteria:</p> |

Peak Detection/Integration Options (continued)

| Selection | Description |
|-----------|--|
| | <p>Shoulders must have a significantly higher Y value at one edge than the other. More importantly, the height of the shoulder above the common value must be much smaller than the height of the “parent” (larger) peak above the same valley. It must be smaller by the Max Shoulder Ratio setting. For example, a setting of 33 implies that shoulders must be smaller than 33% of their parents in terms of height above the common valley. The areas for shoulder peaks are calculated by drawing a skimmed baseline from the left shoulder peak baseline and the group common baseline is considered to be part of the parent peak.</p> <p>Shoulder peaks can only be calculated within a group of peaks. See Maximum group separation. below for a description of peak groups. If the <i>Max Group Separation</i> parameter is set to 0 (no groups), a <i>Max Shoulder Ratio</i> parameter value is not used. Use a value of zero to specify no shoulder peak detection.</p> <p>A value of 33% works well with most data. Use a setting of zero to treat shoulder peaks with a perpendicular drop to the common group baseline instead of a skimmed baseline.</p> <p>If the application detects unwanted baseline noise peaks, try increasing the <i>Sensitivity</i> setting. Conversely, if some peaks are not detected, decrease the value.</p> <p>Maximum group separation.</p> <p>The application normally calculates peak areas by drawing a valley-to-valley baseline from the leading edge to the trailing edge of every identified peak. However, in many traces, the valleys between peaks do not always drop back to the original baseline. If a valley-to-valley baseline is used for this type of peak, the calculated area does not accurately reflect the true area under the peak.</p> <p>The application provides a parameter that allows the calculation of <i>Baseline Groups</i>. A group of peaks is defined by a common baseline that extends from the leading edge of the first peak in the group to the trailing edge of the last. The areas of grouped peaks are calculated by dropping vertical lines from the peak edges down to the group baseline.</p> |

Peak Detection/Integration Options (continued)

| Selection | Description |
|-----------|---|
| | <div data-bbox="560 304 673 409" style="float: left; margin-right: 10px;">  </div> <p data-bbox="690 304 1404 493">There may also be <i>Report Groups</i> defined by the method and assigned group letters from A through Z. Unlike these <i>Baseline Groups</i>, the <i>Report Groups</i> need not be next to one another. The two types of groups are not related.</p> <hr data-bbox="560 504 1429 514"/> <p data-bbox="560 535 1429 1060">The <i>Max Group Separation</i> parameter is used to determine which peaks in a trace have a common baseline. When using peak grouping, the application compares the width (actually double the largest half width) of every identified peak in a trace to the width of the following peak. The <i>Max Group Separation</i> parameter specifies a percentage of the smallest of these two widths in X units. If the edges of two adjacent peaks differ by less than this value, the two peaks constitute a group and are given a common baseline. For example, if two adjacent peaks in the trace have largest half widths of 1 and 1.5 respectively, and the <i>Max Group Separation</i> parameter is set at 20%, then a difference of less than 0.4 X units between the adjacent edges of these peaks would make them a group with a common baseline. If the same two peaks have adjacent edges that are greater than 0.4 X units apart, they do not define a group, and each peak has its own separate baseline.</p> <p data-bbox="560 1102 1429 1375">The areas for grouped peaks are calculated by drawing imaginary vertical lines from the peak edges to the common baseline. Any peaks that share common edges are automatically considered a group and are given a common baseline for any <i>Max Group Separation</i> setting greater than 0. To specify no peak grouping (each identified peak has its own baseline), use a setting of 0. A value of 33% for this parameter works well with most data. Use a setting of zero to force all baselines to be drawn from peak valley to valley.</p> <ul style="list-style-type: none"> <li data-bbox="516 1428 828 1459"> Minimum peak area <p data-bbox="560 1501 1404 1711">This parameter sets the minimum area required for refined, processed peaks to be recognized, identified, and included in the peak table. Any peak with a calculated peak area smaller than the current setting is not detected. Values for this parameter are expressed in terms of the trace X-axis units multiplied by the Y-axis units (e.g., millivolt-minutes).</p> <p data-bbox="560 1753 1404 1785">Setting the Sensitivity parameter to large values (greater than 20%)</p> |

Peak Detection/Integration Options (continued)

| Selection | Description |
|---|--|
| | <p>can cause noise spikes (or dips) on the sides of major peaks to be identified as peaks themselves. If the areas of the peaks are smaller than the Minimum Peak Area parameter, major peaks in the trace may not be identified at all. Exercise caution when using high Sensitivity settings with the Minimum Peak Area parameter.</p> <p>If peaks are not detected by the application, lower the setting with a smaller value. This parameter must be adjusted in conjunction with the Peak Sensitivity and/or Minimum Peak Height parameters above. Peak rejection is accomplished through a combination of peak height and peak area rejection parameters. If the application is not detecting the peak(s) of interest, decrease both parameters.</p> |
|  | <p>For fields and buttons not listed in this table, see Common Fields and Buttons on page 2 - 4.</p> |

G TEMPERATURE PROGRAMMED ANALYSES

Most temperature-programmed experiments are based on the following highly simplified steps:

1. Gas flows into the analyzer.
2. The gas interacts with the sample as the temperature changes.
3. Gas flows past the detector.
4. The detector collects data.
5. The application plots and calculates results.

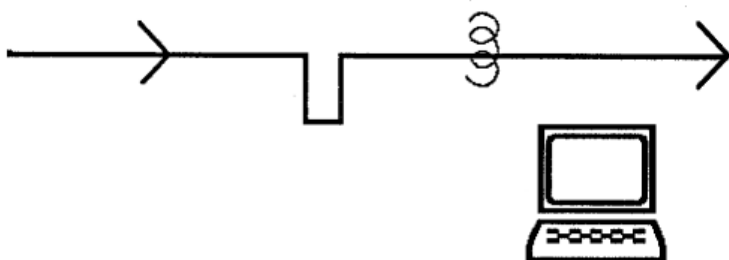

How the Detector Works

The detector contains heated filaments that measure the difference in gas thermal conductivity sensed between the gases flowing over the sample and reference filaments.

The gases flowing past the detector cool the filament by extracting heat. How quickly any type of gas removes heat from the detector is determined by its thermal conductivity¹⁾. A gas with a high thermal conductivity cools the filament rapidly, and more power is required to maintain its temperature. A gas with a lower thermal conductivity removes heat from the filament more slowly.

When the sample reacts with the gas, it causes changes in the composition of the gas and, consequently, changes the thermal conductivity of the gas. These changes are sensed by the detector as an increase or decrease in the amount of power required to maintain the filament at a constant temperature.

Data that are Collected

The detector reports the amount of electricity (in volts) required to keep its temperature constant during the analysis.

1) The thermal conductivity of a gas is its ability to conduct heat. Each gas has a distinct thermal conductivity.

The Role of the Sample Temperature

Because the sample's temperature determines how rapidly it interacts with the analysis gas (or if it reacts at all), data are collected over the range of temperatures specified.

In some experiments, you may prefer to start collecting data at a very low temperature to establish a baseline where the gas is completely unaffected by the sample. In other cases, you may prefer to collect data after a reaction has begun. In still other experiments, your primary interest may be determining the temperature at which the maximum reaction occurs.

For example, consider the example of a Temperature-Programmed Reduction (TPR). During the TPR, a metal oxide is reacted with hydrogen to form a pure metal. This reaction is referred to as "reducing" the metal; for example, TPR of a catalyst containing Platinum. Argon, which has a very low thermal conductivity, is used as a carrier gas. It is blended in a fixed proportion with hydrogen, an analysis gas with a much higher thermal conductivity. Then the gas mixture flows through the analyzer, through the sample, and past the detector.

When the gas blend begins flowing over the sample, a baseline reading is established by the detector. This baseline is established at a low enough temperature that no reduction of the sample is occurring, so the baseline level recorded by the detector is that of the thermal conductivity of the two gases in their fixed proportion. In other words, the proportion of gases flowing over the detector is the same as the proportion of gases entering the analyzer, because at the low temperature, there is no interaction with the sample.

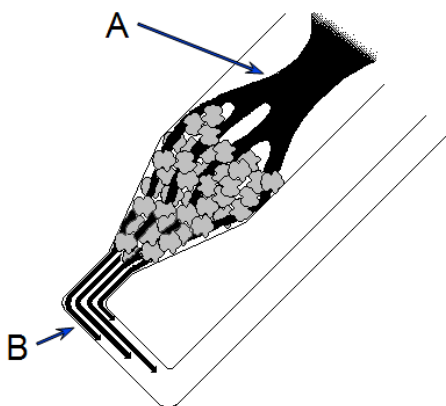

- A. Gas flows into the sample tube and through the sample.
- B. Before the reaction begins, the concentration of gases exiting the sample tube is unchanged after flowing through the sample.

The temperature is then changed, and when a critical temperature is reached, hydrogen atoms in the gas flow react with the sample, forming H_2O molecules. The H_2O molecules are removed from the gas stream using a cold trap. As a result, the amount of hydrogen in the argon / hydrogen gas blend inside the analyzer decreases, and the proportion between the two gases shifts in the direction of argon, as does the mixture's thermal conductivity.

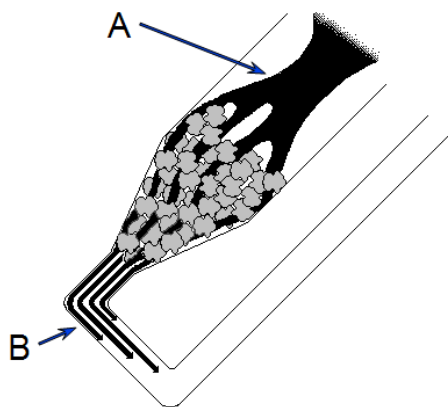

- A. As the temperature changes, the sample begins to react with the gas(es) flowing through it.
- B. The concentration of gases exiting the sample tube is altered after passing through the sample. This change in the gas concentration is recorded by the Thermal Conductivity Detector downstream.

Since argon has a lower thermal conductivity than hydrogen, the mixture's thermal conductivity consequently decreases. The flowing gas removes heat from the filament more slowly, requiring less electricity to maintain a constant filament temperature. The analyzer records the electrical demand as it changes (this is called the detector signal). The detector signal is recorded continuously over a range of temperatures. When these readings are graphed, the data form one or more peaks. Peaks can be positive or negative; negative peaks are shown in this example.

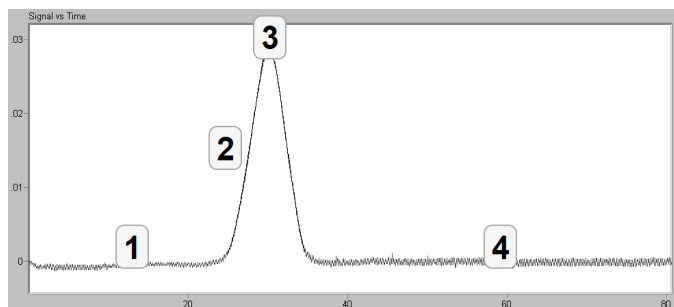

Negative Peaks Legend

| Item | Description |
|------|--|
| 1 | Baseline readings. The gas(es) is (are) not reacting with the sample, so there is no change in the signal from reading to reading. |
| 2 | As the temperature changes, the sample begins to react with one of the gases. Therefore the gas mix is then made up of a larger proportion of the other gas. This causes a shift in the mixture's thermal conductivity. The detector measures this change by recording the change in the amount of electricity required to maintain constant filament temperature. |
| 3 | As temperature continues to increase, the interaction reaches a maximum, then begins to diminish. |
| 4 | As fewer and fewer sample atoms are available to bond with the analysis gas, there is less and less change in the mix of gases flowing into the analyzer and past the detector, so the thermal conductivity shifts back toward the baseline value. |

This example illustrates the fundamental concept upon which the analyzer operates. Of course, the various types of analyses the analyzer can perform result in different types of traces. For example, a pulse chemisorption analysis results in a series of peaks that gradually increases in size as the sample is dosed with separate increments of gas. Initially, the gas uptake by the sample results in smaller peaks. But when all the active sites are saturated, no more gas can be taken up and the peaks become equal.

PEAK AREA

The area beneath each peak is calculated to provide information about the volume of gas reacted during the analysis. The *Calculations* document can be found on the Micromeritics web page (www.micromeritics.com).

AUTOMATIC OPERATION

The analyzer application provides a simple format to specify all the analysis conditions for the experiment; create a sample file which contains sample information and a list of specific steps the analyzer will follow to perform the experiment(s). Then, the analyzer automatically performs the analysis, from controlling the gas mixture and flow rate to monitoring the temperature and pressure. After analysis, use the Peak Editor to adjust the peaks to create reports that contain the data needed, without baseline noise or other undesirable effects.

Because up to 99 experiments can be specified and each experiment can contain up to 99 steps, the analyzer can perform a wide variety of preparation and analysis functions automatically.

SORPTION TRAP

In some cases, it is preferred to trap substances resulting from the reaction. In the previous example, H₂O is produced during the analysis. If the gas flow is passed through the sorption trap at an appropriate temperature, the water can be removed before the gas flows past the detector.

INJECTION LOOP

Injection loops are provided for injecting carefully measured doses of gases for analyses such as Pulse chemisorption. The analyzer is shipped with a 0.5 cm³ loop installed. A 1 mL loop is also available. If the sample file is set so that a loop is used for introducing gas into the analyzer, the analyzer will automatically dose the sample as specified in the sample file.

SAMPLE PREPARATION AND CALIBRATION

Depending on the type of experiment(s) to be performed, sample preparation and/or calibration may be required. Specific instructions are contained in the appropriate sections of this manual.

A sample is prepared for analysis by removing unwanted adsorbates from the surface of the sample. This is usually accomplished by flowing gas over the sample and may include heating the sample. The flowing gas may be inert or chemically active gases may be used to activate the surface.

Calibration routines provide the analyzer and application with the appropriate information to convert electrical signals to physically meaningful data such as volume adsorbed, loop volume, and gas concentration.

**This page
intentionally
left blank**

H WORKSHEETS

Worksheets in this section may be copied as needed.

[*AutoChem Gas Connections Worksheet on the next page*](#)

[*Gas Flow Constant Calibration Worksheet on page H - 3*](#)

[*Manual Injections Worksheet for AutoChem on page H - 5*](#)

[*Sample Data Worksheet for Chemisorption on page H - 6*](#)

AUTOCHEM GAS CONNECTIONS WORKSHEET

Use this form to record the connected gases. Use this form as a checklist against the gases identified in the analyzer application.

Unit number (S/N): _____

Date: _____

Operator: _____

| Preparation Gas | Carrier / Reference Gas | Loop Gas |
|------------------------|--------------------------------|-----------------|
| | | |
| | | |
| | | |
| | | |

GAS FLOW CONSTANT CALIBRATION WORKSHEET

Follow the instructions for calibrating the analyzer's Mass Flow Controllers for a given gas. Use worksheet to record measured values and perform calculations included in this process.

SINGLE GASES

MFC being used (optional)

_____ Preparation

_____ Reference (AutoChem II 2920 only)

_____ Carrier

_____ Analysis (Loop)

Gas: _____

1. MFC flow rate (as set on instrument schematic): _____
2. Measured flow rate (using an external flow meter): _____
3. Convert the flow rate to Standard Temperature and Pressure (STP) using the following formula:

$$\text{Rate at STP} = \text{Rate measured (cm}^3) \times \frac{273.15K}{273.15K + \text{room temp } ^\circ C} \times \frac{\text{atmospheric pressure}}{760\text{mmHg}}$$

Measured rate at STP: _____

4. Enter the value from line 3 in the *Actual flow* field of the Gas Flow Constant Calibration window (**Unit [n] > Gas Flow Calibration**).
5. The new Mass flow constant displays. Enter the Mass flow constant value: _____
6. Click **Accept**.
7. Enter the new Conversion Constant for this gas (from line 5) into the Adsorptive Properties (.ADP) file.

GAS MIXTURES

A conversion constant for a mixture of gases can be determined using the conversion constants for each gas in the mixture. Use the following formula to calculate the conversion constant for the gas mixture:

$$M = \frac{1}{\left[\frac{P_1}{F_1 \times 100}\right] + \left[\frac{P_2}{F_2 \times 100}\right] + \dots + \left[\frac{P_n}{F_n \times 100}\right]}$$

where

- M = mixture conversion constant
- P = percentage of gas *n* in the mixture, expressed as a whole number (example: for 15%, use 15, not .15)
- F = conversion constant (factor) for gas *n*

| Gas Name (n) | Conversion Constant (F) |
|--------------|-------------------------|
| 1. | |
| 2. | |
| 3. | |
| 4. | |
| 5. | |
| 6. | |
| 7. | |
| 8. | |
| 9. | |
| 10. | |
| 11. | |
| 12. | |
| 13. | |
| 14. | |
| 15. | |

Mixture name: _____ Constant (M): _____

MANUAL INJECTIONS WORKSHEET FOR AUTOCHEM

Use this worksheet to list the planned injection volumes, then check indicate if completed.

| Injection | Comments/Volume | Completed |
|------------------|------------------------|--------------------------|
| 1 | | <input type="checkbox"/> |
| 2 | | <input type="checkbox"/> |
| 3 | | <input type="checkbox"/> |
| 4 | | <input type="checkbox"/> |
| 5 | | <input type="checkbox"/> |
| 6 | | <input type="checkbox"/> |
| 7 | | <input type="checkbox"/> |
| 8 | | <input type="checkbox"/> |
| 9 | | <input type="checkbox"/> |
| 10 | | <input type="checkbox"/> |
| 11 | | <input type="checkbox"/> |
| 12 | | <input type="checkbox"/> |
| 13 | | <input type="checkbox"/> |
| 14 | | <input type="checkbox"/> |
| 15 | | <input type="checkbox"/> |
| 16 | | <input type="checkbox"/> |
| 17 | | <input type="checkbox"/> |
| 18 | | <input type="checkbox"/> |
| 19 | | <input type="checkbox"/> |
| 20 | | <input type="checkbox"/> |

