

CHEMISORB AUTO



OPERATOR MANUAL

273-42800-01
Nov 2025
(Rev A)

TRADEMARKS

Alconox is a registered trademark of the Alconox Company.
ChemiSorb Auto is a trademark of Micromeritics Instrument Corporation.
Kalrez is a registered trademark of DuPont Dow Elastomers L.L.C.
Kimwipe is a registered trademark of Kimberly-Clark Corporation.
MicroActive is a trademark of Micromeritics Instrument Corporation.
Micromeritics is a registered trademark of Micromeritics Instrument Corporation.
Microsoft and Windows are registered trademarks of Microsoft Corporation.
Python is a registered trademark of Python Software Foundation.
Viton is a registered trademark of E. I. DuPont Co., Inc.

This application may contain a binary form of the Info-ZIP tool to create .zip files. That source code is provided under the following license:

This software is provided "as is," without warranty of any kind, express or implied. In no event shall Info-ZIP or its contributors be held liable for any direct, indirect, incidental, special or consequential damages arising out of the use of or inability to use this software.

Permission is granted to anyone to use this software for any purpose, including commercial applications, and to alter it and redistribute it freely, subject to the following restrictions:

- 1. Redistributions of source code must retain the above copyright notice, definition, disclaimer, and this list of conditions.*
- 2. Redistributions in binary form must reproduce the above copyright notice, definition, disclaimer, and this list of conditions in documentation and/or other materials provided with the distribution.*
- 3. Altered versions — including, but not limited to, ports to new operating systems, existing ports with new graphical interfaces, and dynamic, shared, or static library versions — must be plainly marked as such and must not be misrepresented as being the original source. Such altered versions also must not be misrepresented as being Info-ZIP releases — including, but not limited to, labeling of the altered versions with the names "Info-ZIP" (or any variation thereof, including, but not limited to, different capitalizations), "Pocket UnZip," "WiZ" or "MacZip" without the explicit permission of Info-ZIP. Such altered versions are further prohibited from misrepresentative use of the Zip-Bugs or Info-ZIP e-mail addresses or of the Info-ZIP URL(s).*
- 4. Info-ZIP retains the right to use the names "Info-ZIP," "Zip," "UnZip," "WiZ," "Pocket UnZip," "Pocket Zip," and "MacZip" for its own source and binary releases.*

Copyright

The software described in this manual is furnished under a license agreement and may be used or copied only in accordance with the terms of the agreement.

WARRANTY

MICROMERITICS INSTRUMENT CORPORATION warrants for one year from the date of shipment each instrument it manufactures to be free from defects in material and workmanship impairing its usefulness under normal use and service conditions except as noted herein.

Our liability under this warranty is limited to repair, servicing and adjustment, free of charge at our plant, of any instrument or defective parts when returned prepaid to us and which our examination discloses to have been defective. The purchaser is responsible for all transportation charges involving the shipment of materials for warranty repairs. Failure of any instrument or product due to operator error, improper installation, unauthorized repair or alteration, failure of utilities, or environmental contamination will not constitute a warranty claim. The materials of construction used in MICROMERITICS instruments and other products were chosen after extensive testing and experience for their reliability and durability. However, these materials cannot be totally guaranteed against wear and/or decomposition by chemical action (corrosion) as a result of normal use.

Repair parts are warranted to be free from defects in material and workmanship for 90 days from the date of shipment.

No instrument or product shall be returned to MICROMERITICS prior to notification of alleged defect and authorization to return the instrument or product. All repairs or replacements are made subject to factory inspection of returned parts.

MICROMERITICS shall be released from all obligations under its warranty in the event repairs or modifications are made by persons other than its own authorized service personnel unless such work is authorized in writing by MICROMERITICS.

The obligations of this warranty will be limited under the following conditions:

1. Certain products sold by MICROMERITICS are the products of reputable manufacturers, sold under their respective brand names or trade names. We, therefore, make no express or implied warranty as to such products. We shall use our best efforts to obtain from the manufacturer, in accordance with his customary practice, the repair or replacement of such of his products that may prove defective in workmanship or materials. Service charges made by such manufacturer are the responsibility of the ultimate purchaser. This states our entire liability in respect to such products, except as an authorized person of MICROMERITICS may otherwise agree to in writing.
2. If an instrument or product is found defective during the warranty period, replacement parts may, at the discretion of MICROMERITICS, be sent to be installed by the purchaser, e.g., printed circuit boards, check valves, seals, etc.
3. Expendable items, e.g., sample tubes, detector source lamps, indicator lamps, fuses, valve plugs (rotor) and stems, seals and O-rings, ferrules, etc., are excluded from this warranty except for manufacturing defects. Such items which perform satisfactorily during the first 45 days after the date of shipment are assumed to be free of manufacturing defects.

Purchaser agrees to hold MICROMERITICS harmless from any patent infringement action brought against MICROMERITICS if, at the request of the purchaser, MICROMERITICS modifies a standard product or manufactures a special product to the purchaser's specifications.

MICROMERITICS shall not be liable for consequential or other type damages resulting from the use of any of its products other than the liability stated above. This warranty is in lieu of all other warranties, express or implied, including but not limited to, the implied warranties of merchantability or fitness for use.

MICROMERITICS CORPORATE PROFILE

Micromeritics is the global leader in analytical instrumentation for the physical characterization of particles, powders, and porous materials. Our advanced technologies provide precise measurement of density, surface area, porosity, activity, and powder flow, supporting research, product development, and quality control. Serving industries like materials science, chemicals, energy, and natural resources, our instruments enable critical advancements in fields such as battery materials, hydrogen economy, and carbon capture. Founded in 1962, Micromeritics operates globally with over 15,000 instruments in daily use, delivering expert support and cutting-edge solutions from our U.S. headquarters and international locations. For more information, please visit www.micromeritics.com.

PATENTS

For patent information, visit www.Micromeritics.com/patents.

CONTACT US

Micromeritics Instrument Corporation

4356 Communications Drive
Norcross, GA 30093-2901 USA
Phone: 1-770-662-3636
www.Micromeritics.com

Instrument Service or Repair

Phone: 1-770-662-3636
International: Contact your local distributor or call 1-770-662-3636
Service.Helpdesk@MalvernPanalytical.com

Micromeritics Application Support

Micromeritics.Support@MalvernPanalytical.com

ABOUT THIS MANUAL

The following can be found on the Micromeritics web page (www.micromeritics.com).

- Calculations document (PDF) (if applicable)
- Error Messages document (PDF) (if applicable)
- Operator Manual (PDF)
- Parts and Accessories

The following symbols or icons indicate safety precautions and/or supplemental information and may appear in this manual:



NOTE — Notes contain important information applicable to the topic.



CAUTION — Cautions contain information to help prevent actions that may damage the instrument or components.



WARNING — Warnings contain information to help prevent actions that may cause personal injury.

GENERAL SAFETY



Do not service or modify this instrument without authorization from Micromeritics Service Personnel. It does not include any user-serviceable parts.



If closed-cell silicone foam pipe insulation is used in this instrument, it is REACH non-compliant.

Chemical Abstract Service and numbers:

- Octamethylcyclotetrasiloxane (D4) – CAS 556-67-2
- Decamethylcyclopentasiloxane (D5) – CAS 541-02-6
- Dodecamethylcyclohexasiloxane (D6) – CAS 540-97-6

Any laboratory equipment can pose a risk to personnel if not operated or maintained correctly. All employees who operate and maintain instruments should be well-familiar with their operation and receive proper safety training and instruction.

- Read the operator manual for any special operational instructions for the instrument.
- Know how the instrument functions and understand the operating processes.



- Ensure that personnel use the appropriate personal protective equipment (PPE) when removing, handling, or repairing equipment. This may include gloves, safety glasses, or other items specific to the equipment or environment.
- When lifting or relocating the instrument, use appropriate lifting and transporting devices designed for heavy equipment. Ensure that enough personnel are available to assist with the movement of the instrument. The ChemiSorb Auto weighs approximately 59 - 63.5 kg (130-140 lb).
- Always follow the safety instructions on the labels affixed to the instrument, and never alter or remove them. During inspections, verify that the safety labels are intact and not worn or damaged.
- Regular maintenance is essential for ensuring personnel safety and the efficient operation of instruments. Consistent upkeep helps enhance safety, ensures optimal test results, and minimizes costly downtime. Neglecting proper maintenance procedures can create unsafe conditions and reduce the lifespan of the instrument.
- Improper handling, disposal, or transportation of potentially hazardous materials can result in serious injury or damage to the instrument. Always consult the SDS when working with hazardous substances. Safe operation and handling of the instrument, supplies, and accessories are the responsibility of the operator.

EQUIPMENT REMOVAL AND REPLACEMENT PROCEDURES

Follow these procedures to safely remove equipment from service for repair or disposal and to ensure safety is maintained when new equipment is put into service.

- Before removing equipment from use for repair or disposal, ensure that all power sources are disconnected and all stored energy sources have been discharged to prevent accidental injury to personnel. Refer to the “Power Instrument On and Off” guidelines for more information.
- Only qualified personnel should perform repairs or dispose of the equipment. This ensures that the work is done safely and that the equipment is properly disposed of in accordance with local regulations.
- When removing equipment for repair, clearly label it with the reason for removal and the date it was taken out of service. This helps ensure that the equipment is not put back into service until it has been properly repaired and tested.
- Depending on the type of equipment being handled, it may be necessary to address environmental safety, such as preventing spills or leaks of hazardous substances during removal or transport.
- When moving an instrument to another location (e.g., by car, truck, or plane), the following is recommended:
 - Pack the instrument in the original shipping materials. If such materials are no longer available, use packaging material (such as a sturdy box with bubble wrap or foam) that will keep the instrument safe from damage during transport.
 - Identify any special handling the package requires (e.g., "Fragile," "This Side Up," or "Do Not Stack Heavy Items on Top").
 - Strap or anchor the package so that it will not tip or fall during transport.
 - Inspect the package on arrival to ensure no damage has occurred. If damage has occurred, contact the responsible party (such as the shipping carrier) for the next steps.
- Follow local regulations and guidelines when disposing of electrical and electronic equipment, especially if classified as hazardous waste. This may include specific requirements for removal, transportation, recycling, or other disposal methods.
- Keep records of all equipment removed from service, including the reason for removal and any repair or disposal actions taken. This helps ensure that the equipment is properly tracked and that safety issues are addressed in a timely manner.
- Ensure that all replacement equipment meets the same safety standards as the equipment being replaced. This helps ensure that safety is not compromised when new equipment is put into service.
- After replacing or repairing equipment, re-calibration or verification may be necessary to ensure the equipment functions correctly and meets operational standards.
- Before returning equipment to service, ensure that it has been properly repaired and tested to ensure that it meets all safety requirements. Only qualified personnel should perform this work.

INTENDED USE

The **ChemiSorb Auto** is a highly automated catalyst characterization system that can perform the following experiments individually or in various sequences:

- BET Surface Area
- BET User Calibration
- Loop Calibration for TCD Analyzers
- Loop Volume
- Pulse Chemisorption
- Temperature-Programmed Desorption Analysis (TPD)
- Temperature-Programmed Oxidation Analysis (TPO)
- Temperature-Programmed Reduction Analysis (TPR)
- Gas Concentration Calibration



The instrument is intended to be operated by trained personnel familiar with the proper operation of the equipment recommended by the manufacturer and as well as relevant hazards involved and prevention methods. Other than what is described in this manual, all use is seen as unintended use and can cause a safety hazard.



The instrument is intended to be used as per applicable local and national regulations.

TRAINING

It is the customer's responsibility to ensure that all personnel operating or maintaining the equipment participate in training and instruction sessions. All personnel operating, inspecting, servicing, or cleaning this instrument must be properly trained in operation and machine safety before operating this instrument.

ENVIRONMENTALLY FRIENDLY USE PERIOD

Hazardous Substances Table

Part Name	Hazardous Substances					
	Lead (Pb)	Mercury (Hg)	Cadmium (Cd)	Hexavalent Chromium (Cr (VI))	Polybrominated biphenyls (PBB)	Polybrominated diphenyl ethers (PBDE)
Cover	o	o	o	o	o	o
Power Supplies	o	o	o	o	o	o
Printed Circuit Boards	x	o	o	o	o	o
Cables, Connectors & Transducers	x	o	o	o	o	o

- o Hazardous substance is below the specified limits as described in SJ/T11363-2006.
- x Hazardous substance is above the specified limits as described in SJ/T11363-2006.

The Environmentally Friendly Use Period (EFUP) for all enclosed products and their parts are per the symbol shown here unless otherwise marked. Certain parts may have a different EFUP (for example, battery modules) and are marked to reflect such. The Environmentally Friendly Use Period is valid only when the product is operated under the conditions defined in the product manual.



SYMBOLS THAT MAY APPEAR ON THE INSTRUMENT

The following symbols or icons indicate safety precautions and/or supplemental information and may appear on your instrument:



Use extreme caution when working on the instrument where one of these symbols may be displayed. These symbols indicate the part may be hot and cause serious burns.



Use the cotton gloves provided in the accessory kit when handling heated surfaces. These cotton gloves are not intended to protect hands when heated surfaces are above 60 °C.



When working on an instrument where this symbol is displayed, refer to the corresponding Operator Manual for additional information.



When this symbol is displayed, toxic or flammable gases require proper venting of exhaust.

This symbol can also indicate the instrument uses mercury which is an extremely toxic substance. Read the Safety Data Sheet (SDS) and be aware of the hazards of mercury and know what to do in the event of a spill or an exposure incident.

**This page
intentionally
left blank**

Table of Contents

About this Manual	iv
General Safety	v
Equipment Removal and Replacement Procedures	vi
1 Analyzer Components	1 - 1
Equipment Options and Upgrades	1 - 2
Gas Requirements and Purity	1 - 3
Specifications	1 - 4
2 About the Software	2 - 1
Analysis Types for TCD Analyzers	2 - 2
Additional Uses of the TCD Analyzer	2 - 2
Applications	2 - 3
Peak Editor for Dynamic Analysis	2 - 3
Menu Structure	2 - 4
Common Fields and Buttons	2 - 5
File Status	2 - 8
Keyboard Shortcuts	2 - 9
Option Presentation	2 - 10
Libraries	2 - 12
Configure the Analyzer	2 - 13
Gas Connections	2 - 13
Unit Selection	2 - 13
Unit Configuration	2 - 14
Set the Initial Temperature	2 - 15
Signal Calibration for Dynamic Analysis	2 - 16
Instrument Status	2 - 22
Show Dashboard	2 - 22
Show Instrument Schematic	2 - 24
Show Status	2 - 30
Show Instrument Log	2 - 31

Export Files	2 - 32
List Files	2 - 33
Report Style	2 - 34
Software Uninstall	2 - 36
Software Updates	2 - 36
3 Sample Files	3 - 1
Create Sample Files	3 - 2
Open a Sample File	3 - 5
Active Metals for Chemisorption Analyzers	3 - 6
4 Parameter Files	4 - 1
Adsorptive Properties	4 - 2
Analysis Conditions	4 - 4
Insert Experiment Steps	4 - 7
Methods	4 - 15
Report Options	4 - 17
5 Perform an Analysis	5 - 1
Analysis Temperature Guidelines for All Analysis Types	5 - 1
Cooling Options	5 - 2
Dewar Precautions	5 - 3
For Glass Dewars	5 - 3
Mixing an IPA/LN2 Slurry	5 - 3
Protect Detector Filaments by Flowing Gas	5 - 4
Prepare for Analysis	5 - 5
Clean and Label Sample Tubes	5 - 5
Prepare the Sample	5 - 7
Create the Sample File	5 - 7
Determine the Sample Mass for Chemisorption	5 - 8
Sample Tube Installation	5 - 11
Fill and Install the Dewar	5 - 11
Perform a Pulse Chemisorption Analysis	5 - 12

Perform a Sample Analysis	5 - 16
Perform a Reference Analysis	5 - 19
6 About Reports	6 - 1
MicroActive Reports	6 - 1
Peak Editor	6 - 2
SPC Report	6 - 8
Report Features / Shortcuts	6 - 9
Graph Features and Shortcuts	6 - 13
Report Examples	6 - 17
Pulse Chemisorption Report	6 - 17
Signal vs Temperature Report	6 - 18
Signal vs Time Report	6 - 19
7 Selected Reports	7 - 1
Active Surface Area Report	7 - 1
Advanced Reports - Python Module	7 - 2
Advanced Reports	7 - 2
BET Surface Area Report	7 - 4
First Order Kinetics Report	7 - 5
Graph Report Options	7 - 6
Loop Calibration Report	7 - 9
Options Report	7 - 10
Pulse Chemisorption Report	7 - 11
Sample Log Report	7 - 13
Summary Report	7 - 13
8 Hardware	8-1
Cold Trap	8-1
Delay Path	8-4
Furnace	8-6
Sample Thermocouple	8-9
Thermocouple Position	8-9

Determine the length of the thermocouple	8-11
Use the Thermocouple Clamp	8-12
Recalibrate the Sample Thermocouple	8-13
Sample Tube	8-15
Sample Tube Installation	8-15
Sample Tube Removal	8-15
Sample Tube Filter or O-ring Replacement	8-16
Septum	8-17
Septum Replacement	8-19
9 Maintenance	9-1
Safe Servicing	9-2
Guidelines for Connecting Gases	9-3
Connect Gas to Analyzer	9-5
Replace a Gas Cylinder	9-7
Perform a Leak Test	9-10
Carrier Gas Path Leak Test	9-11
Loop Gas Path Leak Test	9-12
Preventive Maintenance	9-13
Check and Clean the Dewar	9-14
Clean the Instrument	9-15
Power Instrument On and Off	9-15
Purge the System	9-16
Change the Injection Loop	9-18
10 Troubleshooting	10-1
Enable Manual Control	10-4
Power	10-4
O-ring Compatibility	10-5
Recover from a Power Failure	10-5
11 Analysis Tutorials	11 - 1
BET Surface Area	11 - 1

BET User Calibration	11 - 7
Loop Calibration for TCD Analyzers Tutorial	11 - 11
Loop Volume Calibration Analysis Tutorial	11 - 14
Pulse Chemisorption Analysis Tutorial	11 - 15
Temperature Programmed Desorption Analysis Tutorial	11 - 20
Temperature Programmed Oxidation Analysis Tutorial	11 - 26
Temperature Programmed Reduction Analysis Tutorial	11 - 33
12 Diagnostics	12 - 1
Show All Readings	12 - 1
Diagnostic Test Report	12 - 1
Save Files for Problem Diagnosis	12 - 2
13 Calibration	13 - 1
Gas Concentration Calibration	13 - 2
Loop Calibration	13 - 5
Load Calibration from File	13 - 7
Save Calibration to File	13 - 7
A Advanced Reports - Python Module	A - 1
Advanced Reports	A - 1
Scripts	A - 3
Python Reports	A - 4
MicModule Python Calls	A - 8
B Atomic Weights and Cross-Sectional Areas	B - 1
C Gas Charts	C - 1
D Peak Detection / Integration Options	D - 1
E Temperature Programmed Analyses	E - 1
F Worksheets	F - 1

Gas Connections Worksheet	F - 2
Manual Injections Worksheet	F - 3
Sample Data Worksheet	F - 4
G Exported Data Example	G - 1
Exported Data	G - 2
ChemiSorb Auto Declaration of Conformity - EU	DoC - 1
ChemiSorb Auto Declaration of Conformity - UK	DoC - 2

1 ANALYZER COMPONENTS

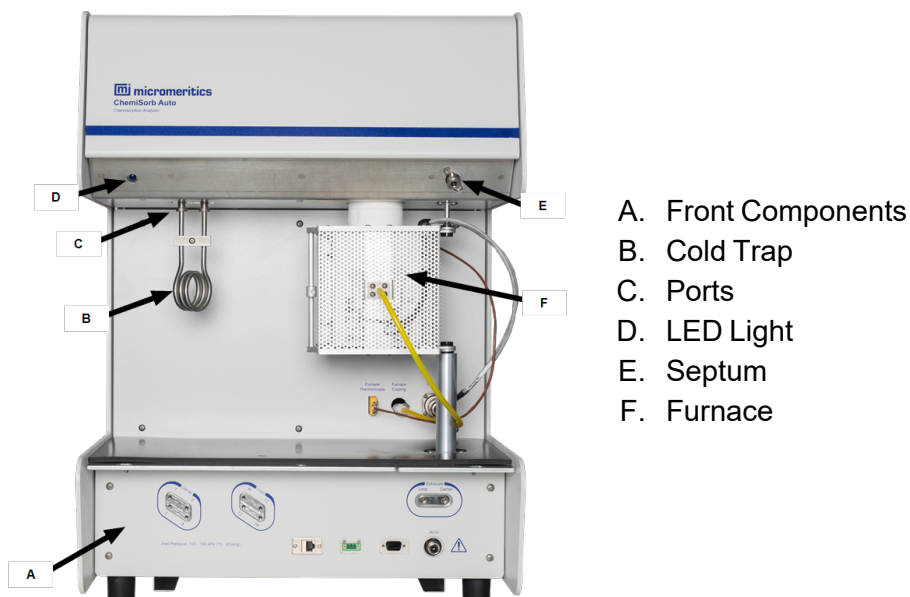

- A. Front Components
- B. Cold Trap
- C. Ports
- D. LED Light
- E. Septum
- F. Furnace

Analyzer Components

Component	Description
Front Components	Front cover is removed to expose the following: <ul style="list-style-type: none"> ■ Ethernet Port ■ Gas Inlet Ports (Carrier, Loop) ■ Exhaust Ports ■ Mass Spec connection ■ COM-1 Port ■ Air In Valve
Cold trap	Used to condense vapors downstream of the sample.
Furnace	Controls the temperature of the sample.
LED light	When lit, indicates the communication between the analyzer and the computer.
Ports	For optional accessories (cold trap and delay path).
Septum port	To inject gas into an analysis.

EQUIPMENT OPTIONS AND UPGRADES

Parts and accessories are located on the [Micromeritics](#) web page.

Option	Description
B.E.T.	Includes delay line used to reduce the perturbation (disturbance) of the gas flow caused by injections of gas through the septum, a 10 mL syringe, additional needles for the syringe (pack of 3) and a plastic beaker for water at ambient temperature for B.E.T. analysis.
CryoCooler	Analyses can be started at sub-ambient temperatures. The CryoCooler can be used to speed throughput by ramping the furnace temperature rapidly to ambient after an analysis.
Mass Spectrometer	Separates isotopes, molecules, and molecular fragments according to mass. Connects directly to a dedicated port for detection and identification of low concentrations of condensable and/or reactive gases.
MicroPrep	Temperature controller and heating mantle for in-situ degassing of zeolite trap. Ambient to 250 °C.
Zeolite Trap	Replaces cold trap with zeolite for trapping moisture generated during experiments. Zeolite should be baked before use.

GAS REQUIREMENTS AND PURITY



Improper handling, disposal, or transportation of potentially hazardous materials can result in serious injury or damage to the instrument. Always consult the SDS when working with hazardous substances. Safe operation and handling of the instrument, supplies, and accessories are the responsibility of the operator.

20 psig compressed gases are required for analyses. Gas cylinders or an outlet from a central source should be located near the analyzer.

Required gases are dependent on the end use and application of the instrument.

Appropriate two-stage regulators which have been leak-checked and specially cleaned are required. Pressure relief valves should be set to no more than 30 psig (200 kPag). All gases should be of a purity listed below. Gas regulators can be ordered from Micromeritics. Parts and accessories are located on the [Micromeritics](#) web page.

Gas	Purity
H2 Ar He CO/He H2/Ar (option)	99.999%

SPECIFICATIONS

Electrical

Voltage	100-240 VAC
Frequency	50/60 Hz
Power	450 VA
Overvoltage category	II

Temperature System

Range	-100 °C to 1000 °C with CryoCooler option Ambient to 1000 °C without CryoCooler option
Selection	Digitally set, 0.1 °C increments
Ramp Rates	0.1 °C/minute minimum. 100 °C/minute maximum Maintains scheduled rate within 5 °C or 1 minute, whichever is larger Heating rates: ≤ 5 °C/min at temperatures ≤1000 °C ≤10 °C/min at temperatures ≤900 °C ≤25 °C/min at temperatures ≤800 °C ≤50 °C/min at temperatures ≤600 °C
Temperature Ramp Rate	± 1% of target

Wetted Materials

Standard System	Stainless steel, gold plated nickel/iron (filaments), Kalrez (most O-ring seals), quartz (sample tubes, thermocouple sheath), quartz wool (supports sample in tube), Inconel- sheathed sample thermocouple (can be placed outside tube or sheathed in quartz), PEEK (Polyether ether ketone - some ferrules), Teflon tubing (most exhaust lines; TCD exhaust is stainless steel for connection of external devices), copper (gas supply lines and BET delay path), nickel plated brass and steel (gas inlet valves), Polyaryletherketone/PTFE composite (rotary valves seals), Silicone/ Teflon sandwich (septum). Buna-N (gas inlet valve seals and O-
-----------------	---

Wetted Materials (continued)

	rings).
--	---------

Gases

Loop	H ₂ , CO, O ₂ , N ₂ O, NH ₃
Carrier	He, Ar, and other gases

Gas Flow Rate

All Mass Flow Controllers (MFCs)	
Manual Control	0 to 100 mL/minute ¹⁾
Automatic Analysis	1 to 100 mL/minute

Gas Delivery

Inlet Ports	8 (4 for carrier gas and 4 loop gas)
Temperature Control	TCD is temperature controlled.

Sample Tube

Type	Fused quartz Flow-Thru sample tubes, for use up to 1100 °C, accepts powders and pellets up to 9 mm in diameter
------	--

Physical

Height	71 cm (28 in.)
Width	51 cm (20 in.)
Depth	62 cm (24.5 in.)
Weight	59 - 63.5 kg (130 - 140 lb)

¹⁾ Rate for Nitrogen; other gases have a different range.

Environment

Temperature	15 °C to 35 °C (59 °F to 95 °F), operating 0 °C to 50 °C (32 °F to 122 °F), non-operating Maximum rate of change of 2 °C per hour
Humidity	20% to 80% relative, non-condensing
Indoor or Outdoor use	Indoor only (not suitable for wet locations) Altitude: 2000 m max (6500 ft) Pollution degree of the intended environment: 2
Location	Instrument should be located in a dust-free, vibration free environment, away from exposure to direct sunlight and direct air drafts.
Degree of Ingress Protection	IPX0

Due to continuous improvements, specifications are subject to change without notice.

2 ABOUT THE SOFTWARE

The analyzer allows other computer programs to run while an automatic operation is in progress. The *Help* menu provides access to the online operator manual.

Report options can be specified when creating the sample file. When running an analysis, data gathered during the analysis process are compiled into predefined reports. Reports can also be defined and generated after an analysis has been run. Each selected report is displayed on its own tab and reflects data collected during the analysis.

The MicroActive feature offers a Windows interface with an easy way to collect, organize, archive, reduce raw data, and store sample files for later use. Scalable and editable graphs and copy and paste graphics are easily generated. Customized reports can be viewed on a computer monitor, printed, or exported for use in other programs.

In addition to customizable standard reports, user-defined calculations and reports can be created through the Advanced reports feature (using Python).

Data can be manipulated and displayed interactively using MicroActive reports.

ANALYSIS TYPES FOR TCD ANALYZERS

The basic concept for all analyses is the same: the filament detects changes in the gas mixture flowing past it. The sample, gas selection, and analysis conditions determine what changes occur.

[*BET Surface Area on page 11 - 1*](#)

[*BET User Calibration on page 11 - 7*](#)

[*Gas Concentration Calibration on page 13 - 2*](#)

[*Loop Calibration for TCD Analyzers Tutorial on page 11 - 11*](#)

[*Loop Volume Calibration Analysis Tutorial on page 11 - 14*](#)

[*Pulse Chemisorption Analysis Tutorial on page 11 - 15*](#)

[*Temperature Programmed Desorption Analysis Tutorial on page 11 - 20*](#)

[*Temperature Programmed Oxidation Analysis Tutorial on page 11 - 26*](#)

[*Temperature Programmed Reduction Analysis Tutorial on page 11 - 33*](#)

The BET surface area analysis evaluates the total surface area of the catalyst before and after chemisorption. Pore-plugging phenomena, which might occur due to the irreversible adsorbed species during chemical reactions, and the occurrence of sintering¹⁾, can be studied.

After outgassing the sample, a mixture of nitrogen and helium (typically 5% to 30% N₂) flows over the sample that is immersed in a liquid nitrogen (LN₂) bath. Both the adsorption and desorption of the N₂ are recorded. The amount of nitrogen desorbed at LN₂ temperatures and the sample weight is used to calculate the total specific surface area.

The entire BET analysis — or even repeat analyses — is performed in situ.

ADDITIONAL USES OF THE TCD ANALYZER

The analyzer may also be used for temperature programmed reactions, catalyst pretreatment, and isothermal reactions. The tremendous flexibility of the analyzer allows the use of custom applications.

Temperature Programmed Reaction

A temperature programmed reaction monitors the products from the reaction between gases and a catalyst at a specified temperature. The analyzer can be programmed to raise the temperature of a catalyst bed at a constant ramping rate as the gases flow through the catalyst. At the optimal temperature, the gases react in the presence of the catalyst, creating products. The products of the reaction and excess reactants can be diverted to a gas chromatograph or to a mass spectrometer to be analyzed.

¹⁾ Sintering is the fusing of small particles (or small features of a sample). Sintering tends to reduce the active surface area.

Catalyst Pretreatment

Catalyst pretreatment usually consists of activating a catalyst before its use in a chemical reaction. For example, a temperature programmed oxidation reaction may require reduction of the catalyst under a flow of H₂ at a specific temperature.

Isothermal Reaction

An isothermal reaction is similar to a temperature programmed reaction except that the catalyst is kept at a constant temperature (isothermal) to perform the catalytic reaction. Both the product of the reaction and the excess reactants can be diverted to a gas chromatograph or to a mass spectrometer to be analyzed.

APPLICATIONS

Catalytic processes that benefit from TPD/TPR analyses include:

- Polymerization
- Hydrogenation
- Catalyst cracking
- Hydrocracking
- Isomerization
- Oxidation
- Dehydrogenation
- Hydrotreating
- Alkylation reforming

PEAK EDITOR FOR DYNAMIC ANALYSIS

[Peak Editor on page 6 - 2](#)

The TCD (Thermal Conductivity Detector) features a Peak Editor, which allows the evaluation of results, peak editing, and reports. Adjusting peak boundaries can be used to eliminate baseline noise or other undesirable effects. The Peak Editor also allows the separation of composite peaks.

MENU STRUCTURE

All program functions use standard Windows menu functionality.

Main Menu Bar Options

Selections	Description
File	Use to manage files used by the application — such as sample files, analysis conditions files, report options files, etc.
Unit [n]	Use to perform analyses, calibrations, and other analyzer operations. <i>Unit [n]</i> displays on the menu bar for each analyzer attached to the computer.
Reports	Use to start or initiate reports and view the results.
Options	Use to change presentation options, set the method and active metals defaults, configure signal calibration, manage libraries, select units, and create report styles.
Window	Use to manage open windows and display a list of open windows. A checkmark appears to the left of the active window.

COMMON FIELDS AND BUTTONS

The fields and buttons in the following table are located in multiple windows throughout the analyzer application and have the same description or function. Fields and button descriptions not listed in this table are found in tables in their respective sections. All entry fields will accept information when using a bar code reader.

Common Fields and Buttons

Selections	Description
Add	Adds an item to the list.
Add Log Entry	Use to enter information that will display in the sample log report that cannot be recorded automatically through the application. Click the button again to enter multiple log entries.
Append	Use to insert one row at the end of a table.
Autoscale	When enabled on report parameters windows, allows the x- and y-axes to be scaled automatically. <i>Autoscale</i> means that the x- and y- ranges will be set to show all the data. If <i>Autoscale</i> is not selected, the entered range is used.
Axis Range	On report parameters windows, the <i>From / To</i> fields are enabled when <i>Autoscale</i> options are not selected. Enter the starting and ending values for the x- and/or y-axes.
Bar Code (default field label name)	Use to enter additional information about the sample, such as a sample lot number, sample ID, etc.
Browse	Searches for a file.
Cancel	Discards any changes or cancels the current process.
Clear	Use to clear the table entries and display only one default value.
Close	Closes the active window and displays a prompt to either accept or reject changes.
Close All	Closes all active windows. If changes were made and not yet saved, a prompt displays for each changed file providing the option to save the file.
Comments	Enter comments to display in the report header about the sample or analysis.
Copies	Selects the number of copies to print. This field is only enabled when <i>Print</i> is selected.
Delete	When working with tables, deletes the selected information.
Destination	Selects the report destination.

Common Fields and Buttons (continued)

Selections	Description
Edit	When working with report parameters, highlight the item in the <i>Selected Reports</i> list box and click Edit to modify the report details.
Exit	Exits the application. If a file is open with unsaved changes, a prompt displays the option to save the changes and exit or exit the application without saving the changes. If an analyzer is currently operating, an additional prompt displays to confirm exiting from the software.
Export	Exports data in a sample file as a .TXT, .XML or .XLS file. When saved to a file, the data can be imported into other applications.
File	Selects the destination directory. Enter a new file name in the <i>File name</i> field or accept the default. Select to save the file as a spreadsheet (.XLS), a portable document format (.PDF), or an ASCII text (.TXT) file format.
File name	Selects a file name from the list shown or enter a file name. If the required file type is not shown, select the type of file from the list.
From / To	Indicates the <i>From</i> and <i>To</i> range for x- and/or y-axes when working with report parameters windows.
Insert	Inserts one row above the selected row in the table.
List	Creates a list of samples or other types of files. The list will contain the file name, date/time the file was created or last edited, file identification, and file status.
Name	Contains a list of files in the selected directory or library.
Next	Moves to the next window or next step.
OK	Saves and closes the active window.
Open	Opens the selected file. Alternatively, double-click the file name in the Name column to open the file.
Prev	Moves to the previous window.
Preview	Previews predefined reports. Click the tabs at the top of the window to preview each selected report. When an analysis has not been run on a sample, this button is disabled.
Print	Sends the report to the selected destination (screen, printer, or file).
Remove	Removes the selected file or files from the list.
Replace	Selects another file where the values will replace the current file's values.

Common Fields and Buttons (continued)

Selections	Description
Replace All	Selects another .SMP file where the values will replace all values for the active sample file. The original file will remain unchanged. No analysis data is added to the file. The only information added is sample information, material properties, liquid properties, analysis, and reporting parameters.
Report	Displays a window to specify report output options.
Save	Saves changes.
Save As	Saves a file in the active window under a different file name. A portion can be saved as a separate, stand-alone file, such as Analysis Conditions or Report Options, when saving sample information.
Start	Starts the report, test, analysis, or operation.
Start Date	Displays a calendar to select the start date for the report.
View	<p>Operation. Displays the data from the current analysis.</p> <p>Instrument Log. Displays recent analyses, calibrations, errors, or messages. Enabled only in Service Test Mode.</p> <p>Instrument Schematic. Displays a schematic of the analyzer system.</p>

FILE STATUS

In the *File Selector* window, the *Mic Description* column and the *Mic Status* column display the file description and file status. The *File Selector* incorporates standard Windows features for resizing windows, reordering and repositioning columns, and right-clicking an entry to display a menu of standard Windows functions.

File Status

File Status	Description
Analyzing	Sample files that are currently used for analysis.
Complete	Sample files used in an analysis that is completed.
Entered	Sample files containing manually entered data.

File Type and File Name Extension

File Type	File Name Extension
Analysis Conditions	.ANC
Calibration	.CAL
Methods	.MTH
Report Options	.RPO
Sample Information	.SMP
SPC Report	.SPC

File Types for Printing or Exporting

File Type	File Name Extension
Portable document format	.PDF
Report	.REP
Spreadsheet	.XLS
Unicode	.TXT
Extensible markup language	.XML

KEYBOARD SHORTCUTS

Shortcut keys can be used to activate some menu commands. Shortcut keys or key combinations (when applicable) are listed to the right of the menu item.

Certain menus or functions can also be accessed using the **Alt** key plus the underlined letter in the menu command. For example, to access the *File* menu, press **Alt + F**, then press the underlined letter on the submenu (such as pressing **Alt + F**) then pressing **O** to open the *File Selector*).



If the underscore does not display beneath the letter on the menu or window, press the **Alt** key on the keyboard.

Keyboard Shortcuts

Selections	Description
Alt + [Unit n]	Opens the <i>Unit [n]</i> menu.
Alt + F4	Exits the program. If files are open with unsaved changes, a prompt to save changes displays.
Alt + H	Opens the <i>Help</i> menu.
Alt + I	Opens the <i>Options</i> menu.
Alt + R	Opens the <i>Reports</i> menu.
Alt + W	Opens the <i>Window</i> menu.
Ctrl + N	Opens a new sample file.
Ctrl + O	Opens the <i>File Selector</i> window.
Ctrl + P	Opens the <i>File Selector</i> to start a report from a selected .SMP file.
Ctrl + S	Saves the open file.
F1	Opens the online help operator manual.
F2	Opens the <i>File Selector</i> window.
F3	When in the <i>File Selector</i> window, opens the file search box.
F4	When in the <i>File Selector</i> window, opens the address bar.
F6	Cascades open windows.
F7	Tiles all open application windows.
F8	Opens the <i>File Selector</i> to start a report from a selected .SMP file.
F9	Closes all open reports.
Shift + F9	Opens the shortcut menu of either the selected component on the analyzer schematic when manual control is enabled or the onscreen reports.

OPTION PRESENTATION

Options > Option Presentation

Use to change the way sample files and parameter files display: *Advanced*, *Basic*, or *Restricted*. Each display option shows sample information and options differently.

Option Presentation Display

Presentation Display	Description
Advanced	Displays all parts of sample and parameter files. Navigate to parameter windows by selecting the tabs across the top of the window.
Basic	Displays sample information in a single window. This display option is used after the parameter files have been created. The previously entered or default parameter files are then accessible using drop-down lists.
Restricted	Displays the sample file in a single window like the <i>Basic</i> display option with certain functions disabled. A password is set when the <i>Restricted</i> option is selected. That same password must be entered to change to the <i>Basic</i> or <i>Advanced</i> display option. This display type is typically used in laboratories — such as the pharmaceutical industry — where analysis conditions must remain constant. The <i>Advanced</i> option is not available in the view selector at the bottom of the window when using the <i>Restricted</i> display option.
Always Open Edit View	Opens files with a <i>Complete</i> status in the tabbed file editor rather than in the view.
Show Splash Screen	Enables (or disables) the splash screen upon application startup.



To change the view for the selected window, use the drop-down list at the bottom of the sample file editor.

The following examples show the same sample file in *Advanced* and *Basic* display. *Basic* and *Restricted* displays will look the same. A password is required if using *Restricted* format.

Option Presentation Examples

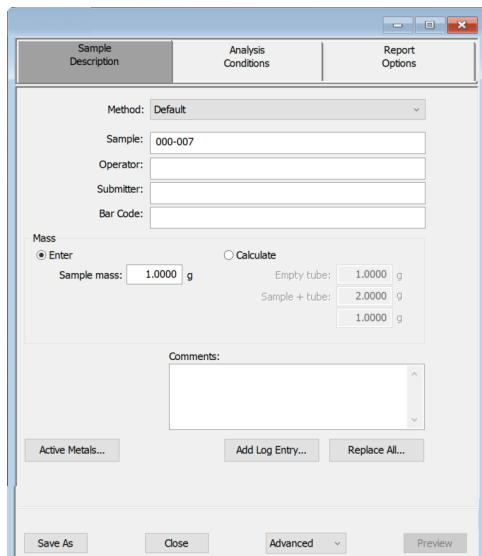

Advanced view

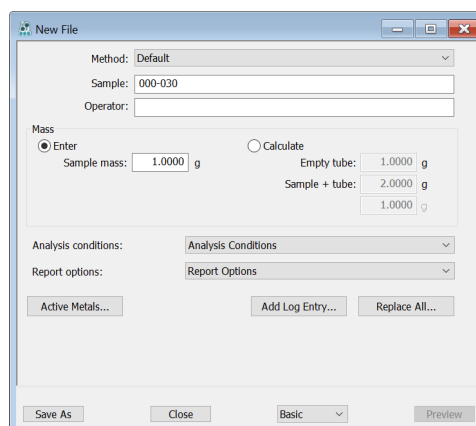

Basic or Restricted view



A sample file must be created for each analysis. The file can be created prior to or at the time of analysis. The sample file identifies the sample, guides the analysis, and specifies report options.

LIBRARIES

Options > Manage Libraries



This feature is not available when using *Restricted* option presentation.

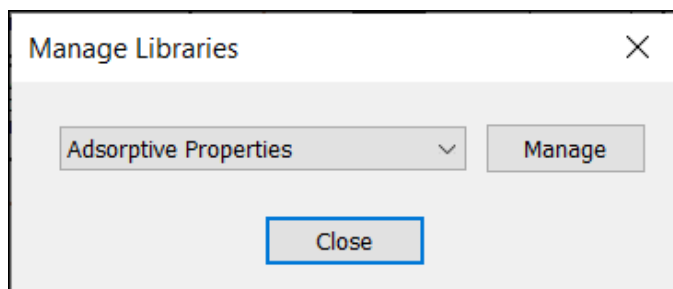

The library provides an easy way to locate and open specific analyzer files. Libraries are located within the *File Selector* window and can be viewed only within the application.

The library gathers sample and parameter files stored in multiple locations, such as folders on a C: drive, a network location, a connected external hard drive, or a connected USB flash drive, and provides access to all files. Even though libraries do not store actual sample and parameter files, folders can be added or removed within each library.

One library can include up to 50 folders. Other items, such as saved searches and search connectors, cannot be included.

When *removing* a folder from a library, the folder and its contents are not deleted from the original file storage location. However, when *deleting* files or folders from within a library, they are deleted from their original file storage location. Deleted files and folders can be recovered from the Recycle Bin located on the Windows desktop.

CONFIGURE THE ANALYZER

GAS CONNECTIONS

Unit [n] > Gas Connections

[Adsorptive Properties on page 4 - 2](#)

Carrier/Reference Gas Connections		Active Gas Concentration %	Blend/Loop Gas Connections		Active Gas Concentration %
Valve 1:	<None>	0.000	Valve 11:	<None>	0.000
Valve 2:	<None>	0.000	Valve 12:	<None>	0.000
Valve 3:	<None>	0.000	Valve 13:	<None>	0.000
Valve 4:	<None>	0.000	Valve 14:	<None>	0.000

Use to configure the gas type connected to each analysis port. The gases available in the drop-down lists come from the Adsorptive Properties (.ADP) files. Click **OK** when done.

UNIT SELECTION

Options > Units

Use to specify how data should appear on the application windows and reports. This menu option is not available if using *Restricted* option presentation in a standard installation environment.

Quantity unit: µmol/g mmol/g cm³/g STP

Pressure unit: kPa mbar mmHg

UNIT CONFIGURATION

Unit [n] > Unit Configuration

Use to display and confirm hardware and software configurations and calibrations of the analyzer.

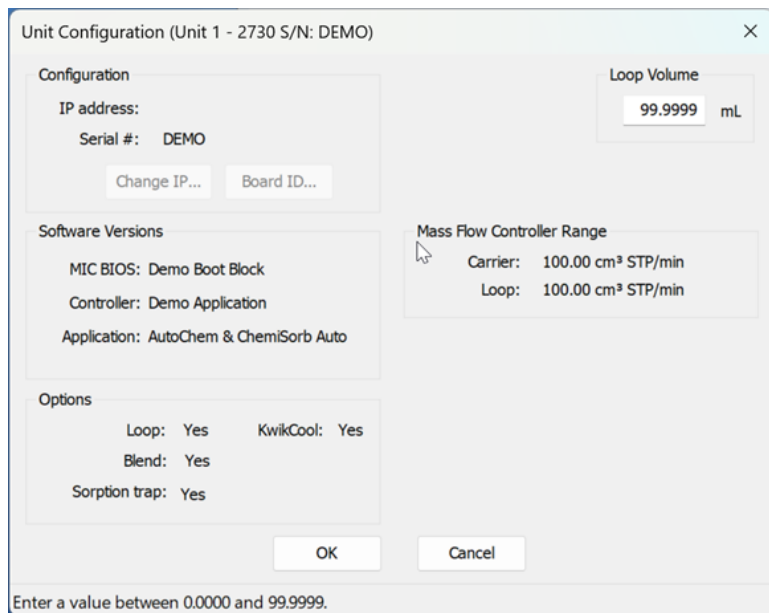

Unit Configuration

Fields	Description
Configuration [group box]	<p>Displays the IP address used by the analysis program, serial number, and type of analyzer.</p> <p>IP address. Displays the IP address of the analyzer.</p> <p>Change IP. [button] Displays the Board ID dialog, which describes the circuit boards in the analyzer. Use the Board drop-down list to select a board to view.</p> <p>Board ID. [button] Click to display information from the circuit boards in the analyzer. Use the drop-down list to select a board to view. The parameters shown cannot be edited.</p> <p>Serial #. Displays the analyzer serial number.</p>

Unit Configuration (continued)

Fields	Description
Loop volume [text box]	Enter the volume of the gas injection loop. Three standard volume loops are provided with the analyzer. The loop volume is determined by performing a loop calibration. See Loop Calibration for TCD Analyzers Tutorial on page 11 - 11 .
Mass Flow Controller Range [group box]	Displays the range of each mass flow controller.
Options [group box]	Displays options installed on the analyzer.
Software Versions [group box]	Displays the software versions of the MIC BIOS, controller software, and analysis program.

SET THE INITIAL TEMPERATURE

Unit [n] > Initial Temperature

Use to set the temperature settings for heat zones when the instrument initializes.

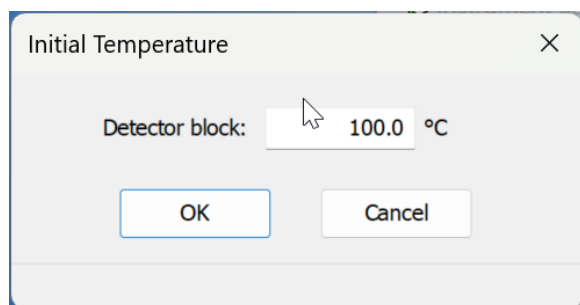

SIGNAL CALIBRATION FOR DYNAMIC ANALYSIS

Options > Signal Calibration

Analyses yield data on signal reading, peak area, temperature, and time. These data are sufficient for many applications; however, volume data may also be needed.

It is not necessary to perform a calibration if volume data are not needed. If volume data are needed, calibration may be performed either before or after the analysis.



This does **not** apply to loop calibration, ambient temperature, and atmospheric pressure.

A group of automatic calibration routines is provided in the form of specialized experiment steps. A calibration run is an analysis using one of these experiment steps. The calibration run can be performed before or after the sample analysis. It can be included as a step within the analysis, or performed as a separate analysis.

After the sample data and calibration data are collected, the calibration file is associated with the sample file, and the sample data are converted to volume. A single calibration run can be associated with an unlimited number of sample data files. For example, TPR yields peak area and the temperature at which maximum reduction occurs. To obtain the volume of gas uptake, a calibration file must be associated with the analysis file. Then, reports are created in which the area data are converted to volume data.

A calibration file can be associated with a sample file by doing the following:

- Going to **Options > Signal Calibration > Defaults** and selecting a default calibration file for each experiment type.
- Using the default file or choose a different file in the *Unit [n] > Sample Analysis* window.
- Clicking **Set Calibration** on the *Peak Editor* window and select from a list of calibration files created after the sample file was used in an analysis.

CREATE A NEW SIGNAL CALIBRATION FILE

Options > Signal Calibration > New

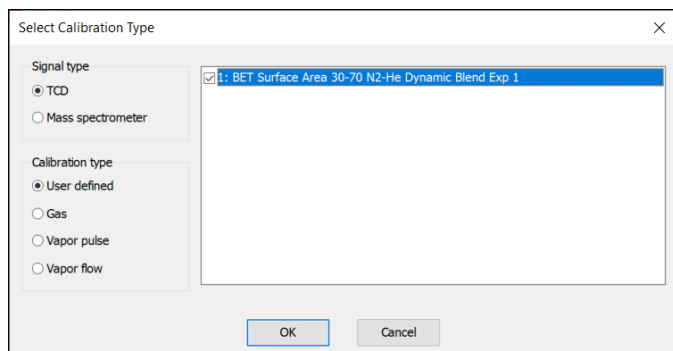

When selecting a *Signal Type* and *Type of Calibration*, only those options used in the original analysis are enabled on the right side of the window.

1. Select the sample file to use for the new signal calibration file.
2. Select the *Signal Type* and *Type of Calibration* options to include in the new calibration file. As selections are made, the experiments from the selected analysis file display on the right side of the window. Only those experiments applicable to the selected signal type and calibration type are enabled. Click **OK**.
3. If prompted, enter the active gas concentration in the carrier gas and loop gas. Click **OK**.
4. Delete (or edit) data in the *Peak Table* as appropriate. Click **Save**.

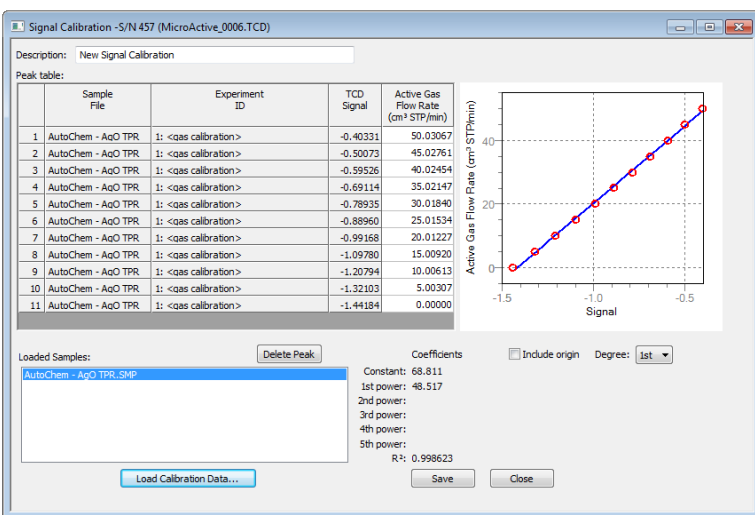

Signal Calibration

Selections	Description
Degree [<i>drop-down box</i>]	Select the power to display in the <i>Coefficients</i> list.
Delete Peak [<i>button</i>]	Removes a peak from the peak table. Select the peak and click Delete Peak .
Description [<i>text box</i>]	Enter a description of the file.
Include origin [<i>checkbox</i>]	Enables or disables the original in the graph.
Load Calibration Data [<i>button</i>]	Use to enter calibration data from a selected file.
 For fields and buttons not listed in this table, see Common Fields and Buttons on page 2 - 5 .	

CREATE A SIGNAL CALIBRATION REPORT

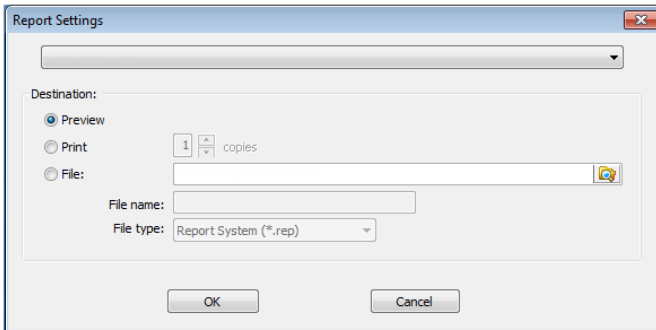

Select a previously defined signal calibration file from the drop-down list, then select the print destination.

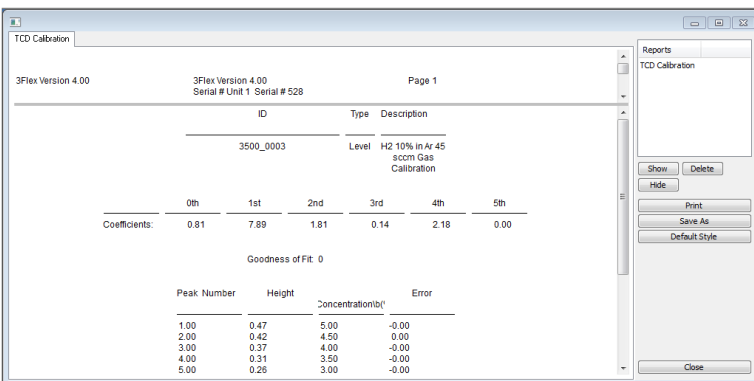

OPEN A SIGNAL CALIBRATION FILE

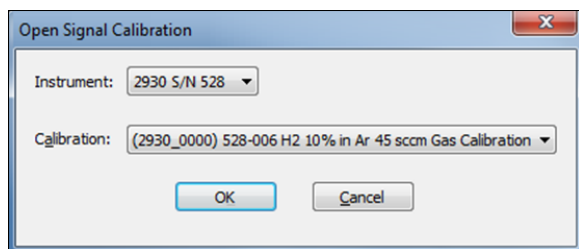

Select a previously defined signal calibration file from the drop-down list. If a calibration file already exists, select the serial number from the drop-down serial number list. When a new calibration file is saved with a new serial number, the new serial number displays in the *Serial Number* drop-down list.

If this is the first calibration file to be saved, the *Serial Number* drop-down will not display until the first calibration file is saved.

LIST SIGNAL CALIBRATION FILES

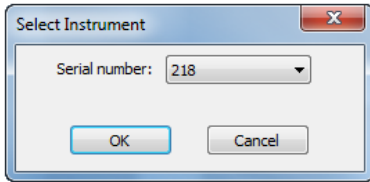

Displays a list view of previously defined signal calibrations for the selected serial number.

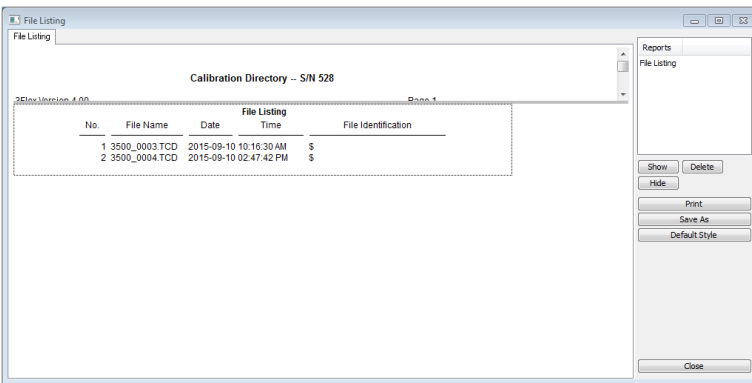

INSTRUMENT STATUS

SHOW DASHBOARD

Unit [n] > Show Dashboard

Data for the dashboard comes from the logged diagnostic data. The dashboard remains current as the relevant diagnostic data items are updated. The gauges will be updated even if the dashboard window is not open.

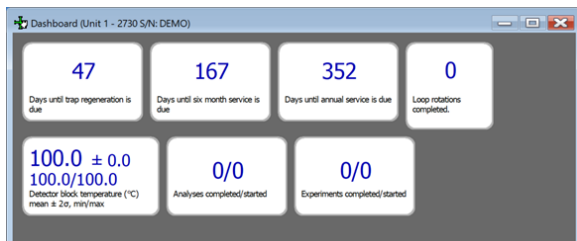

Red numbers on the dashboard require attention. To reset the dashboard numbers, right-click on the dashboard setting, then click [Reset](#).

Dashboard Gauges

Selections	Description
Days until six month service is due	Analyzer service is recommended every six months. The number of days until the anniversary of the last service is shown. The displayed value is updated at least once per day and when the service time is reset. When the displayed value is 30 or less, the value text is shown in red. Red negative numbers display if service is past due.
Days until annual service is due	Annual analyzer service is recommended. The number of days until the anniversary of the last service is shown. The displayed value is updated at least once per day and when the service time is reset. When the displayed value is 30 or less, the value text is shown in red. Red negative numbers display if service is past due.

Dashboard Gauges (continued)

Selections	Description
Loop rotations completed	Displays the number of completed loop rotations.
Detector block temperature	Displays the statistics of the detector block temperature reading. The mean, the value at two standard deviations, the minimum and the maximum display.
Analyses completed / started	Displays N/M where N is the number of analyses that have finished data collection and M is the number of analyses started. Analyses canceled or terminated by errors before the termination stage starts are not counted as completed.
Experiments completed / started	Displays N/M where N is the number of experiments that have finished data collection and M is the number of experiments that have been started. Analyses canceled or terminated by errors before the termination stage starts are not counted as completed.

SHOW INSTRUMENT SCHEMATIC

Unit [n] > Enable Manual Control

Unit [n] > Show Instrument Schematic

[Enable Manual Control on page 10-4](#)



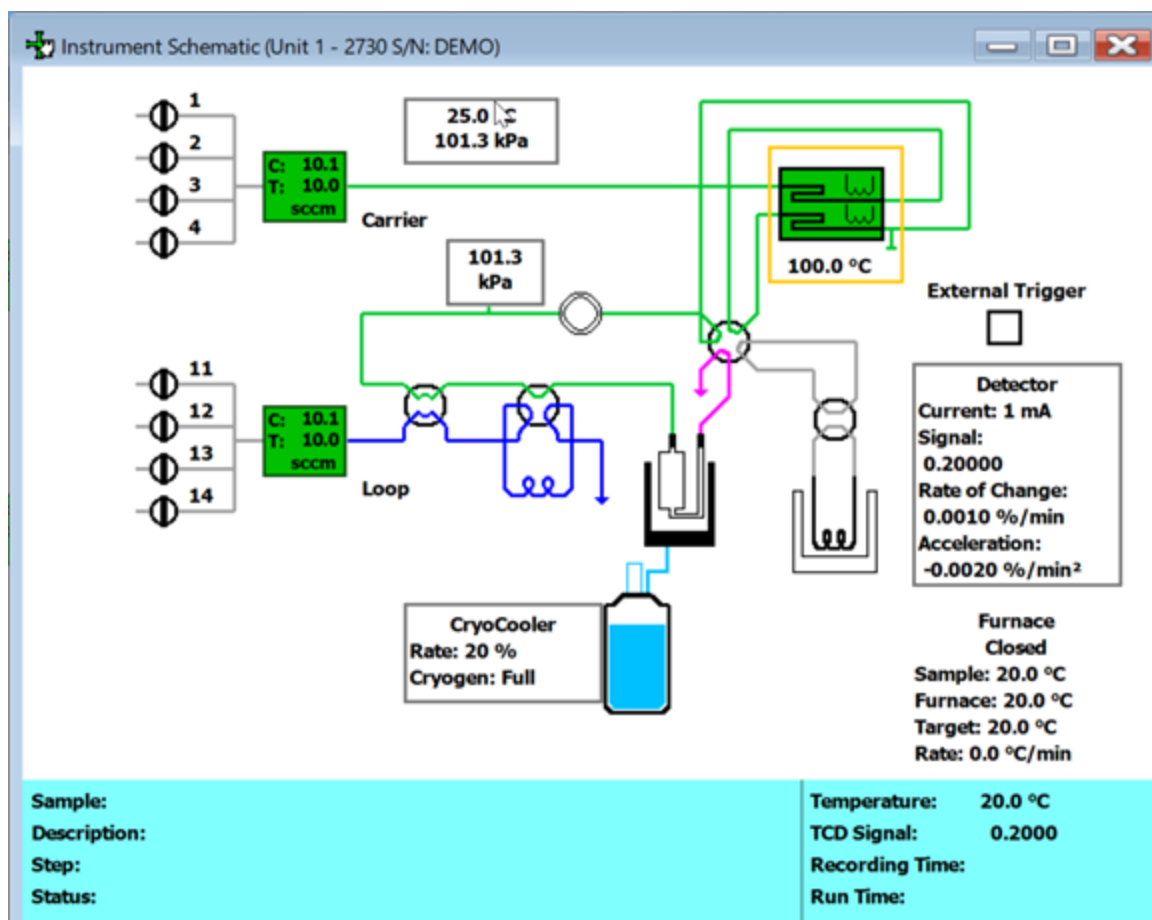

[Gas Pathways on page 2 - 29](#)



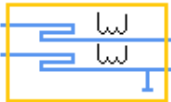

Analysis Valve Descriptions

Valve	Description
1 through 4	Carrier gas inlet ports
11 through 14	Loop gas inlet ports



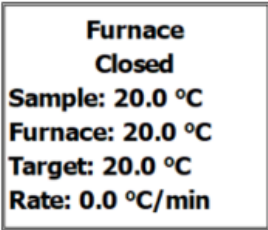
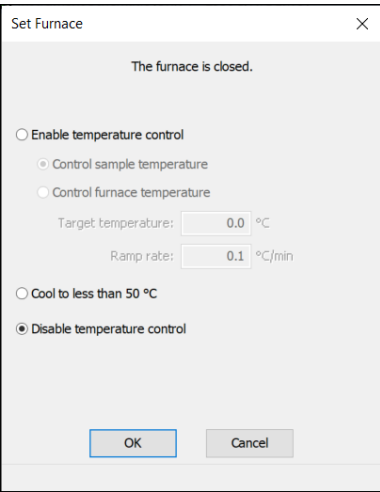

Analyzer Schematic Icons

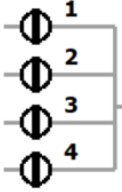
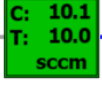
Icon or Symbol	Description
	<p>Closed Valve. Yellow indicates a closed valve. When manual control is disabled, closed valves appear white.</p>
	<p>CryoCooler. Displays only if installed. The CryoCooler can be set from 0 to 100%.</p> <div data-bbox="594 495 974 760" style="border: 1px solid gray; padding: 5px; margin: 10px 0;"> <p style="text-align: right;">Set CryoCooler ×</p> <p>Motor speed: <input type="text" value="20"/> %</p> <p style="text-align: center;"> <input type="button" value="OK"/> <input type="button" value="Cancel"/> </p> <p style="font-size: small;">Enter a value between 0 and 100.</p> </div> <p>Blue. Indicates the Dewar is full</p> <p>Red. Indicates the Dewar is empty. When the pump speed is set to 100%, the Dewar displays as red and empty, a warning light illuminates, and the pump beeps continuously.</p> <p>Yellow. Indicates Dewar level is unknown and pump rate is set to zero (for CryoCooler III installations only).</p>
	<p>Detector Heat Zone. Set the detector heat zone by clicking anywhere in the orange box. Set the Filament Temperature by clicking the detector rectangle on the right side of the schematic.</p> <div data-bbox="594 1222 980 1528" style="border: 1px solid gray; padding: 5px; margin: 10px 0;"> <p style="text-align: right;">Set Detector ×</p> <p><input checked="" type="checkbox"/> Enable detector</p> <p>Filament temperature: <input type="text" value="245"/> °C</p> <p style="text-align: center;"> <input type="button" value="OK"/> <input type="button" value="Cancel"/> </p> </div>
<p style="text-align: center;">External Trigger</p> 	<p>External Trigger. Controls the contact closure used to trigger an external mass spectrometer.</p>

Analyzer Schematic Icons (continued)

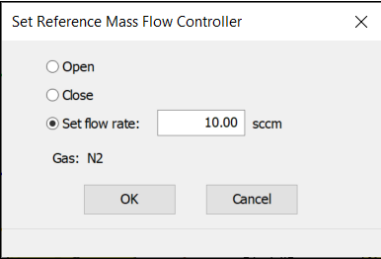

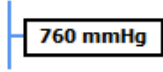
Icon or Symbol	Description
	<p>Furnace. Controls the sample furnace temperatures and cooling level.</p>  <hr/> <p> Sample or Furnace temperatures significantly above 1000 °C will cause accelerated wear on furnace components and lead to premature failure of the furnace. Temperatures should be set at or below 1000 °C, or operator should minimize time operating above 1000 °C.</p>
	<p>Gas Inlet Valves. The inlet displays the gas mnemonic if one is assigned. Right-click the inlet valve to open or close the valve.</p>
	<p>Mass Flow Controller. Controls the flow of gas into the analyzer. The MFC target and flow rate are displayed. Right-click and select an option:</p> <ul style="list-style-type: none"> ▪ Open. Fully opens the MFC. ▪ Close. Closes the MFC to stop gas flow. ▪ Set. Displays the applicable Mass Flow Controller dialog box in which you can open the controller, close the controller, or set the flow rate.

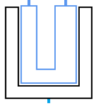
Analyzer Schematic Icons (continued)

Icon or Symbol	Description
	 <ul style="list-style-type: none"> <input type="radio"/> Open <input type="radio"/> Close <input checked="" type="radio"/> Set flow rate: 10.00 sccm <p>Gas: N2</p> <p>OK Cancel</p> <ul style="list-style-type: none"> Zero. Sets the MFC to read zero flow under current conditions.
	<p>Open Valve. Green indicates an open valve.</p>
	<p>Pressure Transducer. Displays the current pressure in the carrier gas path, upstream from the septum but downstream from the Mass Flow Controller. It cannot be manually controlled.</p>
	<p>Rotary Valve. Controls the gas flow through the cold trap, sample tube, loop, and optional vapor generator. Controls the gas flow through the trap, sample tube, loop, and optional vapor generator. Select the needed state. From left to right, the valves and their states are:</p> <ul style="list-style-type: none"> Cold Trap. Bypass, Trap Analysis. Analyze, Prepare Loop. Fill, Inject
	<p>Sample Furnace. Controls the temperature of the sample. Click to display the sample temperature, the target temperature, the furnace temperature, and the ramp rate. Right-click the icon and select <i>Set Temperature</i> to change the <i>Set Point</i> and/or the <i>Ramp Rate</i>.</p>

Instrument Schematic Shortcut Menus

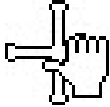
Schematic Shortcuts

Icon or Symbol	Description
Valve options 	Close. Closes the selected valve. Open. Opens the selected valve.
Temperature control options 	Select <i>Set Temperature</i> to modify furnace.

Gas Pathways

The colored lines that lead from the gas inlets through the analyzer and to the exhaust represent the current flow path. A different color path represents each gas source:

Red	Exhaust gas
Green	Carrier gas
Blue	Blended gas or loop gas
Gray	Inactive gas



When a gas valve is opened, or the flow path is changed, it takes several minutes for the new gas to move through the entire system.

The behavior of the loop valve is one example. When an analysis includes a loop injection, the schematic shows the path available in *Fill* mode, then *Inject* mode.

- In *Fill* mode, the analysis gas enters the loop, and the excess gas vents out the exhaust.
- In *Inject* mode, the analysis gas bypasses the loop and exits the analyzer through the exhaust.

At that time, the carrier gas path is available from the inlet all the way through the loop, through the sample tube, and past the detector.

When the valve switches to *Inject* mode, the quantity of analysis gas contained in the loop — one exact unit — is pushed out of the loop and through the sample tube by the carrier gas. When the application is recording the TCD signal, the loop injection shows as a peak on the *Results* view of the *Analysis* window.

The analysis gas may be greatly dissipated as it travels out of the loop and through the sample tube, particularly if the carrier gas flow rate is low. Higher carrier gas flow rates minimize the dispersion of the loop gas.

SHOW STATUS

Unit [n] > Show Status

Use to show the current status for each port.

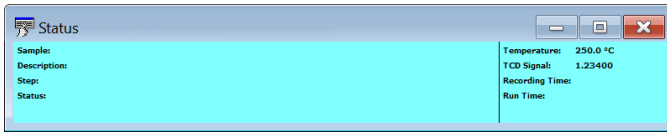

If multiple units are attached to the computer, select *Show Status* on each *Unit [n]* menu. The status for all units displays.

SHOW INSTRUMENT LOG

Unit [n] > Show Instrument Log

Use to display a log of recent analyses, calibrations, errors, or messages.

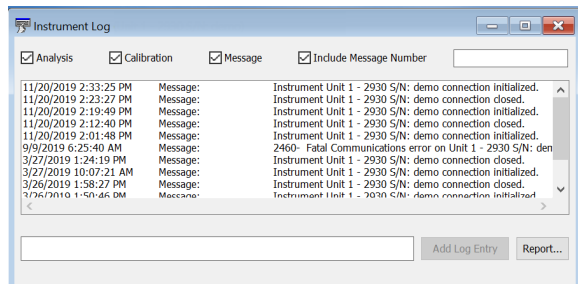

Instrument Log

Selections	Description
Add Log Entry [button]	Use to enter information to appear in the sample log report that cannot be recorded automatically through the application. Click the button again to enter multiple log entries.
Analysis/ Calibration/ Message [checkbox]	Select the logs to display.
Include Message Number [text box]	<p>Enter any of the following information in the message text box to generate a log report that includes the following:</p> <ul style="list-style-type: none"> ■ Message number in the text box to view all occurrences of the entered message, ■ Asterisk in the message box to see all numbered messages, or ■ Several message numbers separated by commas to include only messages with those numbers. <p>Numbered messages contain more detailed information about analyzer operation.</p>
Report [button]	Click to select the print destination and the report start date.
 <p>For fields and buttons not listed in this table, see Common Fields and Buttons on page 2 - 5.</p>	

EXPORT FILES

File > Export

Provides the option to print the contents of one or more sample or parameter files to either the screen, a printer, or a file. Data can be exported as a .PDF, .TXT, .XML, or .XLS file format. The type of data to include or exclude can be selected during the export process. The data can be imported into other applications that read these file formats when exported to a file.

1. Click **List** and open an .SMP file.
2. Select an experiment and the applicable options.
3. Click **OK**.

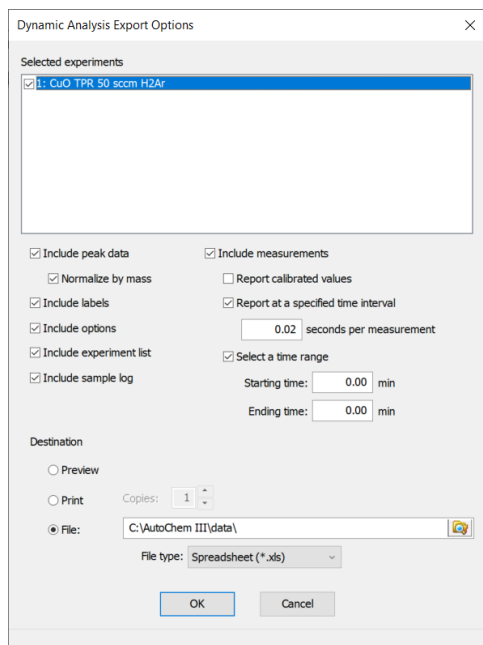

LIST FILES

File > List

Provides the option to create a list of sample file information —such as file name, date, time the file was created or last edited, file identification, and file status.

Select one or more files from the file selector, click **List**, then provide the file destination.

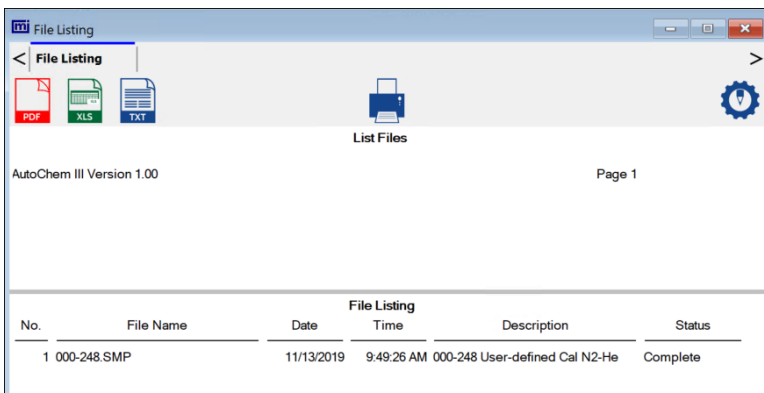

**Example of
File List**

List Report Icons

Icon	Description
	Click to save the previewed file in a PDF format.
	Click to save the previewed file in a spreadsheet format.
	Click to save the previewed file in ASCII TXT format.
	Click to send the file to a printer.
	Click to define the report style. See Report Style on the next page .

REPORT STYLE

Options > Report Style

A report style can also be configured from an analysis with a *Completed* status.

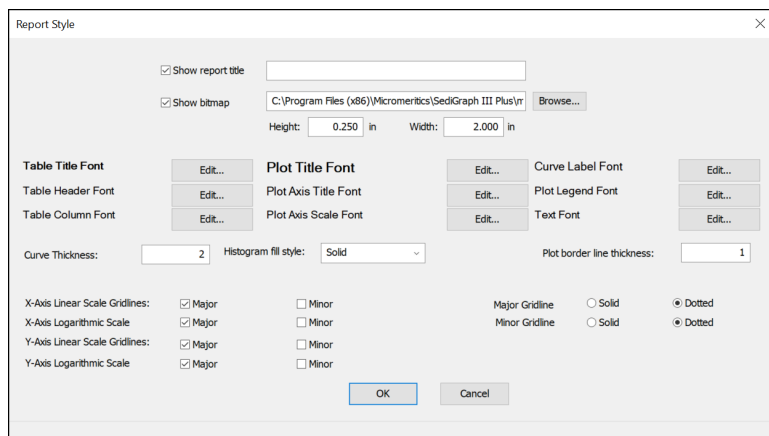

Report Style

Selections	Description
Curve Thickness [text box]	Enter a value to indicate the thickness of the curve on reports.
Font Options [button]	Click Edit to select font type, font style, and font size.
Histogram fill style [drop-down box]	Select how histograms are to appear on the report.
Linear Scale Logarithmic Scale [check box]	Select major and/or minor lines to display in reports for the logarithmic and linear scales. Deselect this option to remove the grid lines.
Major Gridline Minor Gridline [button]	Select if the major and/or minor grid lines should appear as solid or dotted lines.
Plot border line thickness [text box]	Enter a value to indicate the thickness of the plot borders on reports.
Show bitmap [text box]	Use to show a graphic on the report header. Height/Width. Enter the height and width of the selected graphic. These values determine the graphic's appearance on the generated report.

Report Style (continued)

Selections	Description
Show report title [text box]	Select then enter a report title to appear on the report header.
 For fields and buttons not listed in this table, see Common Fields and Buttons on page 2 - 5 .	

SOFTWARE UNINSTALL

The software can be uninstalled in two ways. Either method removes only the files required to run the software, not the analysis files.

- Click the Windows *Start* icon. Scroll to the Micromeritics entry. Select the *Uninstall [analyzer]* option, then follow the prompts.
- Locate the *uninstall.exe* file in *C:\Program Files (x86)\Micromeritics\[analyzer name]* (or wherever the application was installed). Double-click the *uninstall.exe* file, then follow the screen prompts.

SOFTWARE UPDATES



A User Account Control in the Windows operating system must be enabled to ensure all components of the Micromeritics application are correctly installed. If UAC is not enabled, right-click the *setup.exe* installer file and select *Run as administrator*.

The most current version of the instrument software can be found on the Micromeritics web page (www.micromeritics.com).

When performing a software update, existing data files are not overwritten.

Insert the setup media into the media drive. The setup program starts automatically. If the program does not start automatically, navigate to the installation media drive, locate and double-click the *setup.exe* file.

3 SAMPLE FILES

Sample files include the information required by the analyzer to perform analyses and collect data. A sample file identifies the sample, guides the analysis, specifies report options, and may be displayed in *Advanced*, *Basic*, or *Restricted* presentation display mode. After data is collected, the file is shown in MicroActive mode or the tabbed file editor.

A sample file consists of parameter sets; however, parameter sets can also stand alone. A sample file may be created either before or at the time of analysis.

Parameter files allow for repeated use of parameter sets. For example, if the same analysis conditions exist for multiple analyses, an *Analysis Conditions* file containing the recurring conditions can be created. When the sample file is created, the *Analysis Conditions* file can be selected for the analysis conditions. Once it becomes part of the new sample file, the new file can be edited, as needed, without affecting the original *Analysis Conditions* file.

The analysis application contains a default method. A method is a template for sample files that contains the parameters to be used for an analysis. When a new sample file is created, all the parameters are filled with the values in the default method.



To change the view for the selected window, use the drop-down list at the bottom of the sample file editor.

CREATE SAMPLE FILES

File > New Sample > [.SMP File]

File > Open > [.SMP File]



Analysis condition defaults for metal stoichiometry factors can be set using the sample information metal table editor. Stoichiometry factors can also be set for each pulse chemisorption experiment using the analysis conditions experiment step editor. If required, stoichiometry factors for a completed pulse chemisorption experiment can be viewed and modified using the peak editor's stoichiometry settings window.



For dynamic analyses, the *Loop Volume* and *Environmental Default* values must be correct before starting an analysis.

Each analysis must be linked with a sample file before the analysis can proceed. A sample file can consist of parameter files; however, parameter files can also stand alone.

Specify or change the option presentation by selecting **Options > Option Presentation** or use the view selector drop-down list at the bottom of the window.

Sample files created in the *Basic* option presentation are selected from parameter files created in the *Advanced* option presentation. The values specified in the parameter portions of the default method are the defaults for new sample files. To navigate from one set of parameters to another, select the parameter tab across the top of the window.

**Advanced
option presentation**

**Basic or Restricted
option presentation**

Sample Files

Selections	Description
Active Metals [<i>button</i>]	Displays a list of active metals. See Active Metals for Chemisorption Analyzers on page 3 - 6 .
Add Log Entry [<i>button</i>]	Use to enter information that will display in the sample log report that cannot be recorded automatically through the application. Click the button again to enter multiple log entries.
Bar Code [<i>text box</i>]	Use to enter additional information about the sample, such as a sample lot number, sample ID, etc.
Comments [<i>text box</i>]	Enter comments to display in the report header about the sample or analysis.
Mass [<i>group box</i>]	<p>Enter a value for sample mass. Mass can be changed any time before, during, or after analysis.</p> <p>Enter. Enables the <i>Sample mass</i> field. Enter a value for the sample mass.</p> <p>Calculate. Enables the <i>Empty tube</i> and <i>Sample + tube</i> fields. Enter the values necessary to calculate the sample mass. The equation used to calculate sample mass:</p> $Mass_{sample} = Mass_{sample+tube} - Mass_{tube}$
Method [<i>drop-down box</i>]	Select a method from the drop-down list.

Sample Files (continued)

Selections	Description
Operator [<i>text box</i>]	Enter operator identification information. This field label may have been renamed or may not display if modified in Options > Default Methods .
Sample [<i>text box</i>]	Enter a sample description.
Submitter [<i>text box</i>]	Enter submitter identification information. This text box may have been renamed or may not display if modified in Options > Default Methods .
	For fields and buttons not listed in this table, see Common Fields and Buttons on page 2 - 5 .

OPEN A SAMPLE FILE

File > Open > [.SMP File]



When working with an existing sample file, consider copying the sample file to maintain the original configuration options.

File Status	Displays
No Analysis	Tabbed file editor
Complete Analyzing	Peak Editor view

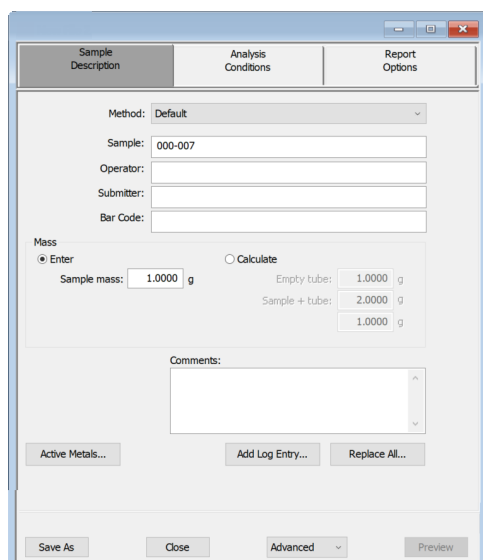

**Tabbed file editor in
Advanced view**

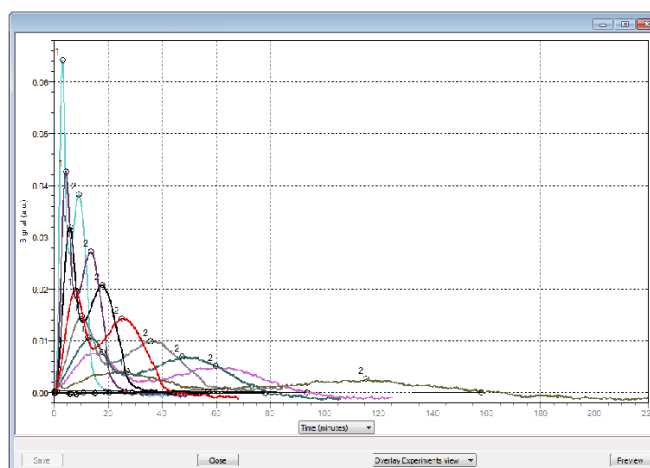

Peak Editor View

To view the tabbed file editor for a sample file with a *Complete* status, select *Advanced* from the view selector drop-down list at the bottom of the window.

ACTIVE METALS FOR CHEMISORPTION ANALYZERS

Options > Active Metals Defaults

Or, click **Active Metals** on the *Sample Description* tab when using the *Advanced* presentation option.

[Atomic Weights and Cross-Sectional Areas on page B - 1](#)

Up to 20 elements can be specified. The default sample weight % is zero.

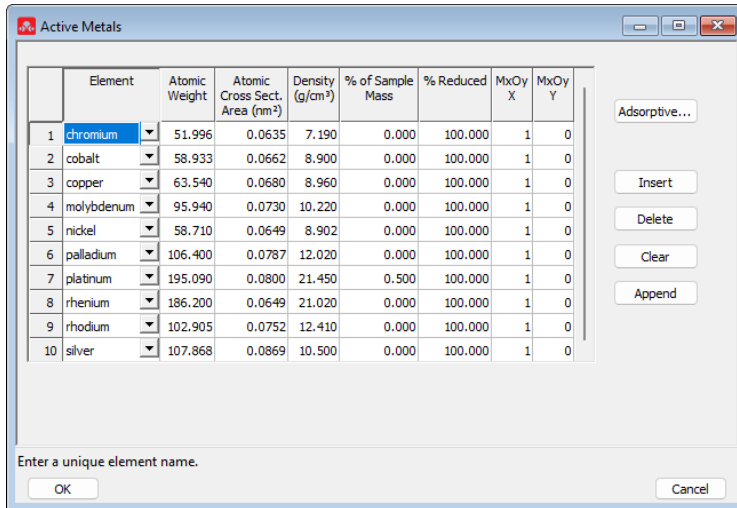

	Element	Atomic Weight	Atomic Cross Sect. Area (nm ²)	Density (g/cm ³)	% of Sample Mass	% Reduced	MxOy X	MxOy Y
1	chromium	51.996	0.0635	7.190	0.000	100.000	1	0
2	cobalt	58.933	0.0662	8.900	0.000	100.000	1	0
3	copper	63.540	0.0680	8.960	0.000	100.000	1	0
4	molybdenum	95.940	0.0730	10.220	0.000	100.000	1	0
5	nickel	58.710	0.0649	8.902	0.000	100.000	1	0
6	palladium	106.400	0.0787	12.020	0.000	100.000	1	0
7	platinum	195.090	0.0800	21.450	0.500	100.000	1	0
8	rhenium	186.200	0.0649	21.020	0.000	100.000	1	0
9	rhodium	102.905	0.0752	12.410	0.000	100.000	1	0
10	silver	107.868	0.0869	10.500	0.000	100.000	1	0

Enter a unique element name.

OK Cancel

Active Metals

Selections	Description
% of Sample Mass [column]	Percentage, by mass, of each element contained in the sample.
% Reduced * [column]	The percent of metal reduced during preparation.
Atomic Cross Sect. Area (nm ²) [column]	Atomic cross-sectional area of the element.
Atomic Weight [column]	Atomic weight of the element.
Density g/cm ³ [column]	Density of the element.
Element [drop-down box]	Select or enter the active metal.
M _x O _y , X * M _x O _y , Y * [column]	X and Y values specify the empirical formula for metal and oxygen, respectively, in a metal oxide.
 For fields and buttons not listed in this table, see Common Fields and Buttons on page 2 - 5 .	

* Options are shown only when using the **Active Metals** button on the *Sample Description* tab.

**This page
intentionally
left blank**

4 PARAMETER FILES

Parameter files allow for repeated use of parameter sets. For example, if the same analysis conditions exist for multiple analyses, an *Analysis Conditions* file containing the recurring conditions can be created. When the sample file is created, the *Analysis Conditions* file can be selected for the analysis conditions. Once it becomes part of the new sample file, the new file can be edited, as needed, without affecting the original *Analysis Conditions* file.

Methods include both analysis conditions and report options, offering the most convenient way to repeat most analyses.

Predefined parameter files are included with the program and can be edited as needed, or new parameter files created.

The following file types can exist as part of the sample file as well as individual parameter files.

Parameter File Types

File Type	File Extension
Adsorptive Properties	.ADP
Analysis Conditions	.ANC
Method	.MTH
Report Options	.RPO

ADSORPTIVE PROPERTIES

File > Open > [.ADP File]

Adsorptive properties provide the adsorptive (analysis gas) characteristics for the analysis.

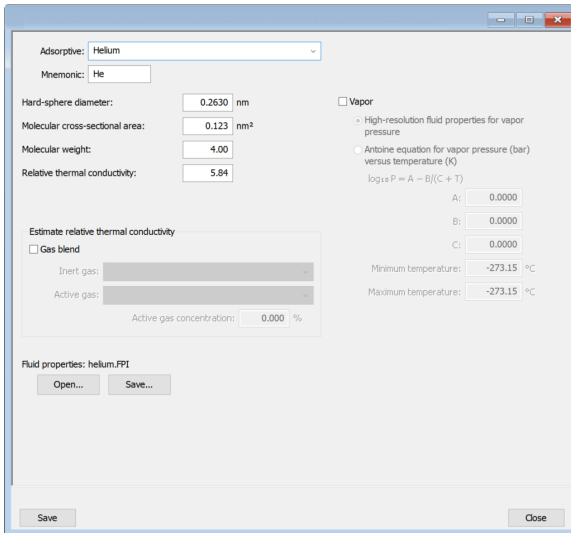

Adsorptive: Helium
Mnemonic: He

Hard-sphere diameter: 0.2630 nm
Molecular cross-sectional area: 0.123 nm²
Molecular weight: 4.00
Relative thermal conductivity: 5.84

Vapor

High-resolution fluid properties for vapor pressure
 Antoine equation for vapor pressure (bar) versus temperature (K)
 $\log_{10} P = A - B/(C + T)$
A: 0.0000
B: 0.0000
C: 0.0000
Minimum temperature: -273.15 °C
Maximum temperature: -273.15 °C

Estimate relative thermal conductivity
 Gas blend
Inert gas:
Active gas:
Active gas concentration: 0.000 %

Fluid properties: helium.fpi
Open... Save...
Save Close

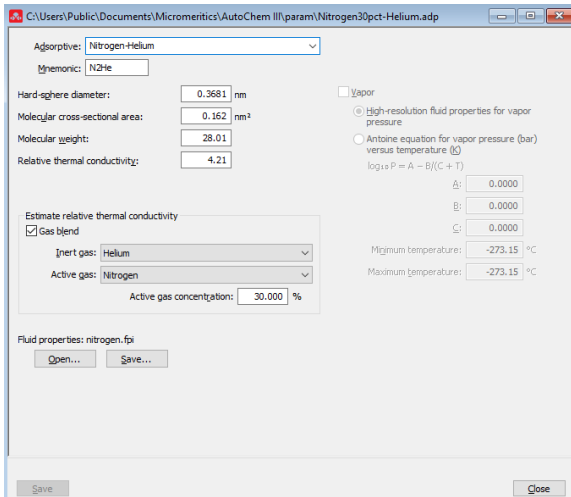

Adsorptive: Nitrogen-Helium
Mnemonic: N2He

Hard-sphere diameter: 0.3681 nm
Molecular cross-sectional area: 0.162 nm²
Molecular weight: 28.01
Relative thermal conductivity: 4.21

Vapor

High-resolution fluid properties for vapor pressure
 Antoine equation for vapor pressure (bar) versus temperature (K)
 $\log_{10} P = A - B/(C + T)$
A: 0.0000
B: 0.0000
C: 0.0000
Minimum temperature: -273.15 °C
Maximum temperature: -273.15 °C

Estimate relative thermal conductivity
 Gas blend
Inert gas: Helium
Active gas: Nitrogen
Active gas concentration: 30.000 %

Fluid properties: nitrogen.fpi
Open... Save...
Save Close

Gas Blend

Adsorptive Properties

Selections	Description
Adsorptive [drop-down box]	Name of the adsorptive gas whose properties are being defined.
Thermal Conductivity [group box]	Select if a gas blend will be used for the estimated Relative Thermal Conductivity. Select the gases to be used in the blend. Gas blend. [check box] Select to specify a preblended mixture of a chemically inert gas and a chemically active gas. The blend's <i>Mass Flow Constant</i> and <i>Relative Thermal Conductivity</i> are automatically calculated from those for the two gases in the blend.
Fluid properties [button]	Use to import parameters from a Fluid Properties (.FPI) file. Changing fluid properties should only be necessary if an adsorptive is to be used for which no adsorptive properties are provided. Contact Micromeritics Scientific Services if new fluid properties are required.
Hard-sphere diameter [text box]	Estimate of the molecular size used in calculating the thermal transpiration correction.
Mnemonic [text box]	Enter the mnemonic name for the adsorptive.
Molecular cross-sectional area [text box]	The area that a single adsorbed molecule occupies on the surface of the sample. It is used in surface area calculations.
Molecular weight [text box]	The molecular mass is used for the weight % column of the isotherm tabular report and the pressure composition isotherm plot.
Relative thermal conductivity (or Thermal conductivity) [text box]	Enter the thermal conductivity relative to Air.
<div style="display: flex; align-items: center;">  <p>For fields and buttons not listed in this table, see Common Fields and Buttons on page 2 - 5.</p> </div>	

ANALYSIS CONDITIONS

[Insert Experiment Steps on page 4 - 7](#)

File > Open > [.ANC File]

Analysis conditions specify the parameters used to guide an analysis.



When inserting experiments, select the instrument type in the *View conditions for* drop-down list.

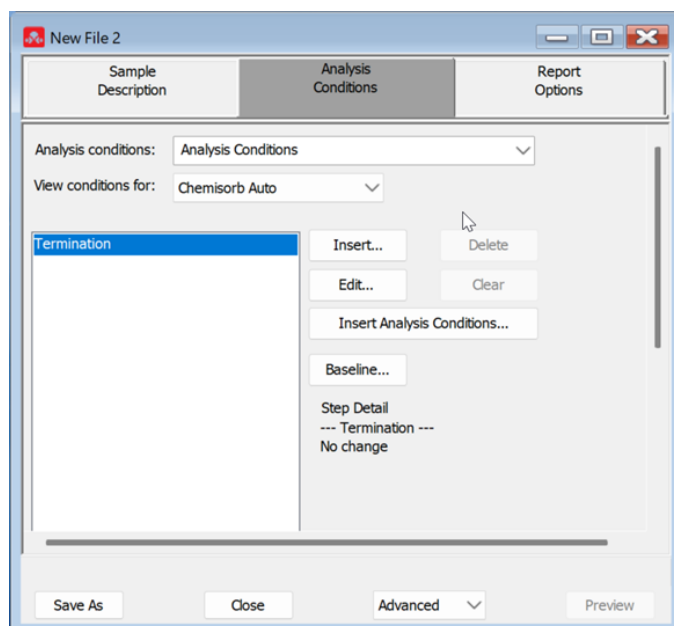

Analysis Conditions

Selections	Description
Analysis Conditions [drop-down box]	Use to browse for an <i>Analysis Conditions</i> file that contains analysis condition parameters to be used in the analysis.

Analysis Conditions (continued)

Selections	Description
Baseline [<i>button</i>]	<p>Specifies baseline settings if a <i>Wait</i> step depends upon the <i>Baseline</i>.</p> <div style="border: 1px solid black; padding: 5px; margin-bottom: 10px;"> <p style="text-align: right; margin: 0;">✕</p> <p style="margin: 0;">Baseline Detection Parameters</p> <hr/> <p style="margin: 0;">Stable Baseline A "stable baseline" is detected when the signal's slope is below the threshold for the indicated duration.</p> <p style="margin: 0;">Slope threshold: <input type="text" value="0.010"/> %/min</p> <p style="margin: 0;">Duration: <input type="text" value="5.00"/> min</p> <hr/> <p style="margin: 0;">Change From Baseline A "change from baseline" is detected when the signal's acceleration exceeds the threshold for the indicated duration.</p> <p style="margin: 0;">Acceleration threshold: <input type="text" value="0.200"/> %/min²</p> <p style="margin: 0;">Duration: <input type="text" value="0.10"/> min</p> <hr/> <p style="margin: 0;">Return To Baseline A "return to baseline" is detected when the signal's acceleration falls below the threshold for the indicated duration.</p> <p style="margin: 0;">Acceleration threshold: <input type="text" value="0.050"/> %/min²</p> <p style="margin: 0;">Duration: <input type="text" value="1.00"/> min</p> <p style="text-align: center; margin: 0;"> <input type="button" value="OK"/> <input type="button" value="Cancel"/> </p> <p style="font-size: small; margin: 0;">Enter a value between 0.001 and 10.000.</p> </div> <p>Establishes the <i>Slope</i> or <i>Acceleration</i> threshold and <i>Duration</i> for determining what constitutes a <i>Stable Baseline</i>, a <i>Change From Baseline</i>, and a <i>Return To Baseline</i>. These values control whether a particular change in the signal is significant to the current experiment — such as defining a stable baseline.</p> <p>Some <i>Wait</i> steps are contingent upon the values selected — such as if the experiment contains a <i>Wait until Baseline is stable</i> step, the signal is compared to these values to determine if a stable baseline has been established. Lower slope/acceleration values and longer durations create a more rigorous definition of these factors than higher values and shorter durations.</p> <p>Stable Baseline. [<i>group box</i>] Detected when the signal slope is below the threshold for the indicated duration.</p> <p>Change from Baseline. [<i>group box</i>] Detected when the signal acceleration exceeds the threshold for the indicated duration.</p> <p>Return to Baseline. [<i>group box</i>] Detected when the signal acceleration falls below the threshold for the indicated duration.</p>

Analysis Conditions (continued)

Selections	Description
Delete [<i>button</i>]	Deletes the currently selected step. If the step is an experiment, a prompt displays to confirm deletion of all steps for that experiment.
Edit [<i>button</i>]	Displays the applicable dialog box for the selected step.
Insert [<i>button</i>]	<p>Inserts a new step into the task list.</p> <p>To ensure safe operation and reliable results, a chemically inert gas flow should be inserted between flows of two chemically reactive gases such as hydrogen and oxygen.</p>
Insert Analysis Conditions [<i>button</i>]	Loads an entire list of steps, baseline parameters, and peaks parameters from the selected dynamic analysis conditions file.
Step Detail [<i>group box</i>]	Displays summary information about the highlighted experiment step.
View conditions for [<i>drop-down box</i>]	Selects the instrument model to use, and the editor only shows the options available for that model. The selection is saved and reused when the file is reopened and disabled during and after analysis.
 <p>For fields and buttons not listed in this table, see Common Fields and Buttons on page 2 - 5.</p>	

INSERT EXPERIMENT STEPS

Experiments can be customized to control the analysis reaction. When an experiment is inserted, the initial conditions are specified first, then the individual steps.

To insert an experiment:

1. On the *Analysis Conditions* tab, click **Insert** to insert an experiment. A list of all available experiments is displayed.

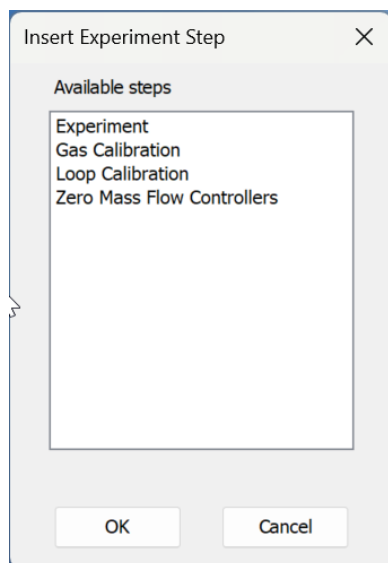

2. Select the experiment step.
3. Click **OK**. The applicable step dialog box is displayed. See the *Experiment Fields* table for details on each step.



Data from one experiment are not available for editing until the next experiment in the analysis has begun recording.

Experiment Fields

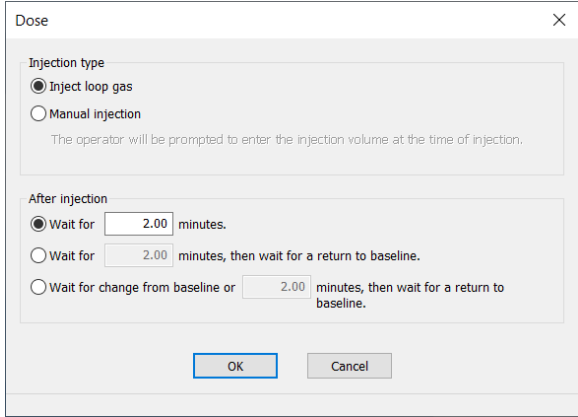
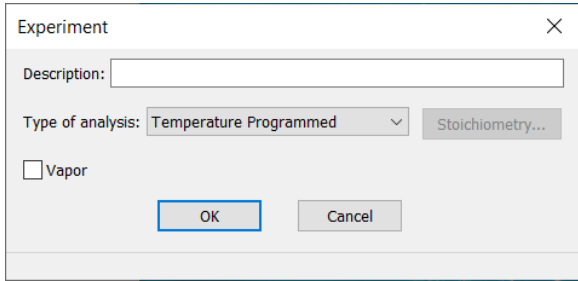
Selections	Description
Dose	 <p>Injection Type [group box]:</p> <ul style="list-style-type: none"> ▪ Inject loop gas. [button] Automatically injects the contents of the loop into the path that leads to the sample. The contents of the loop are pushed out of the loop by the carrier gas. ▪ Manual injection. [button] Prompts the user to inject a dose of gas into the septum using a syringe. <p>After Injection. Specify the amount of time to wait after injection has occurred.</p>
Experiment	 <p>Description. [text box] Description of the experiment.</p> <p>Type of analysis. [drop-down box]</p> <p>See Analysis Types for TCD Analyzers on page 2 - 2. If <i>Pulse Chemisorption</i> is selected, the Stoichiometry button is enabled. When modifying the <i>Active Metals</i> table during the insertion of a <i>Pulse Chemisorption</i> experiment, changes to the <i>Active Metals</i> table on the <i>Sample Description</i> tab are not affected. This is useful when sequencing multiple experiments and Stoichiometry is different from one experiment to the next.</p>

Experiment Fields (continued)

Selections	Description
	<p>Bath temperature. [text box] Applies to <i>Physisorption Surface Area</i> only. Calculates P_0 using the entered bath temperature.</p> <p>Stoichiometry. [button] Opens the <i>Active Metals</i> table. Specify the percent of sample weight of the active metals in the sample and the stoichiometry factor. See Active Metals for Chemisorption Analyzers on page 3 - 6.</p> <p>Vapor. [checkbox] If <i>Temperature Programmed, Pulse</i> or <i>Other</i> is selected, the Vapor checkbox is enabled and a drop-down list is displayed. Select the Vapor to be used</p>
Gas Calibration	<p>Use to calibrate the TCD so that peak areas can be converted to gas quantities. During a gas calibration, a series of known gas mixtures flows through the analyzer and the resultant signal readings are recorded. The analyzer can then use these data to calculate the concentrations of unknown mixtures flowing past the detector during subsequent analyses.</p> <p>Calibration Gases. [drop-down box] Select the <i>Carrier</i> and <i>Loop</i> gases to be used in this calibration. The gases available are those specified in an Adsorptive Properties [.ADP] file.</p> <ul style="list-style-type: none"> ▪ Reference flow rate. [text box] Enter a flow rate for the calibration gases. ▪ Maximum active gas concentration. [text box] Enter the maximum percentage for the active gas concentration. <p>Description. [text box] Description of the experiment.</p> <p>Detector block. [text box] Enter the temperature for the detector block.</p> <p>Filament temperature. [selection] Enter the temperature for the filament.</p> <p>Set external trigger. [checkbox] If selected, the contact closure used to trigger an external mass spectrometer will be activated. If deselected, the contact closure will be deselected.</p>

Experiment Fields (continued)

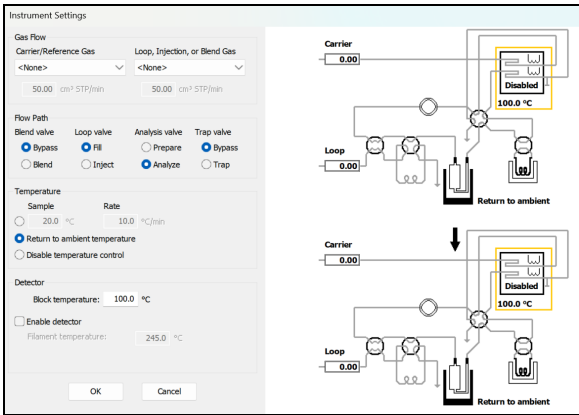
Selections	Description
Instrument Settings	<p>As instrument settings are changed in the left window, changes are highlighted on the schematic at the bottom right window.</p>  <p>Gas Flow. [group box] Select the gases to be used in this analysis along with the flow rates. The gases available are those specified in an Adsorptive Properties [.ADP] file. See Adsorptive Properties on page 4 - 2 and Gas Charts on page C - 1 for gas combinations. Indicate if a Different reference rate should be used along with the applicable rate.</p> <p>Flow Path. [group box] Select the step to be performed at each valve.</p> <p>Temperature. [group box] Enter the sample and rate temperatures.</p> <ul style="list-style-type: none"> ■ Disable temperature control. [button] Disables the temperature control. ■ Return to ambient temperature. [button] Allows the furnace temperature only (not the sample temperature) to return rapidly to a temperature between 14 °C and 50 °C. <p>Detector [group box]:</p> <ul style="list-style-type: none"> ■ Block temperature. [text box] Enter the block temperature. ■ Enable detector. [checkbox] Specify if the detector should be enabled and the applicable Filament Temperature.

Experiment Fields (continued)

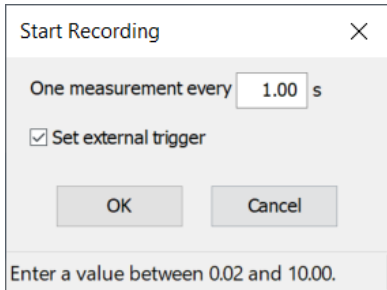
Selections	Description
Loop Calibration	<p>Use to verify the volume of the loop for use in calculations on analyses that use the loop. Sample analysis data yield signal vs. temperature data and peak areas. Associating the sample file with a loop calibration file makes it possible for the application to convert sample data to volume values.</p> <p>Calibration Gases. [<i>drop-down box</i>] Select the <i>Carrier</i> and <i>Loop</i> gases to be used in this calibration. The gases available are those specified in an Adsorptive Properties [.ADP] file. Enter a Flow rate for each gas.</p> <p>Description. [<i>text box</i>] Description of the experiment.</p> <p>Filament temperature. [<i>selection</i>] Enter the temperature for the filament.</p> <p>Number of injections. [<i>text box</i>] Enter the number of manual and automatic injections (3-10) to be done with the loop during calibration.</p> <p>Temperature. [<i>group box</i>] Enter the temperatures for the Detector block.</p>
Start Recording	 <p>Specifies how frequently the signal reading is recorded. A <i>Stop Recording</i> step is inserted in the steps automatically when a <i>Start Recording</i> step is inserted. Multiple steps can be inserted between the <i>Start Recording</i> and <i>Stop Recording</i> steps.</p> <p>One measurement every [n] seconds. [<i>text box</i>] Specify the frequency of measurements.</p> <p>Set external trigger. [<i>check box</i>] If selected, the contact closure used to trigger an external mass spectrometer will be activated. If deselected, the contact closure will be deselected. If this option is enabled, the external trigger signal will be set at the beginning of recording and turned off at the end of recording.</p>

Experiment Fields (continued)

Selections	Description
	<p>If a <i>Start Recording</i> step is immediately followed by a step that prompts an immediate peak, peak data are recorded before any baseline readings can be collected. To collect some baseline data before the first peak, insert a <i>Wait for [n] minutes</i> step after the <i>Start Recording</i> step but before the step which causes the peak.</p>
<p>Start Repeat Sequence</p>	<div data-bbox="555 485 1032 789" style="border: 1px solid gray; padding: 5px; margin-bottom: 10px;"> <p>Start Repeat sequence ×</p> <p><input type="radio"/> Repeat until peaks are equal or <input type="text" value="20"/> times.</p> <p><input type="radio"/> Repeat until peaks are zero or <input type="text" value="20"/> times.</p> <p><input checked="" type="radio"/> Repeat <input type="text" value="20"/> times.</p> <p><input type="radio"/> Repeat until peaks match the first peak or <input type="text" value="20"/> times.</p> <p style="text-align: center;"> <input type="button" value="OK"/> <input type="button" value="Cancel"/> </p> </div> <p>Specifies the duration of the repeat sequence. Automatically inserts a <i>Start Repeat</i> and a <i>Stop Repeat</i> in the list of steps. Multiple experiment steps can be inserted within the <i>Repeat</i> loop.</p> <p>Repeat until peaks are equal or [n] times. <i>[button]</i> Stops repeating the steps within the loop when the last two peaks are equal to within 5% of the area, or when the maximum number of repeats is reached. This option is useful when performing H₂ or CO pulse chemisorption on supported metal catalysts.</p> <p>Repeat until peaks are zero or [n] times. <i>[button]</i> Stops repeating the steps within the loop when the last two peaks are each less than 10% of the area of the first peak, or when the maximum number of repeats is reached. This option is useful when performing an N₂O decomposition for characterizing copper catalysts.</p> <p>Repeat [n] times. <i>[button]</i> Stops repeating the steps within the loop when the specified number of times is reached.</p> <p>Repeat until peaks match the first peak or [n] times. <i>[button]</i> Stops repeating the steps within the loop when the last two peaks each match the first peak to within 10% of its area or when the maximum number of repeats is reached.</p>

Experiment Fields (continued)

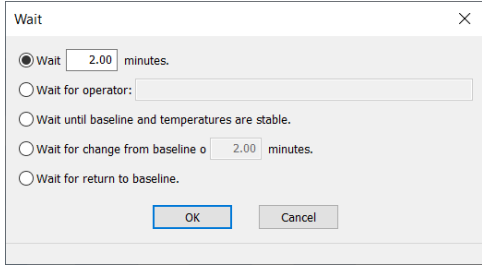
Selections	Description
Wait	 <p>Specify a waiting routine.</p> <p>Wait [n] minutes. [button] Specify the time to wait.</p> <p>Wait for operator. [button] Enter a description of the operator task. During an analysis, the entered message displays at the appropriate time. The analysis continues after the operator clicks OK.</p> <p>Wait until baseline and temperature are stable. [button] Specify if the analysis should wait until the baseline and temperature become stable, then click Baseline to specify the settings.</p> <p>Wait for change from baseline or [n] minutes. [button] Specify the time to wait, click OK, then click Baseline to specify the settings.</p> <p>Wait for return to baseline. [button] Waits for a return to baseline. If enabled, click OK, then click Baseline to specify the settings.</p>

Experiment Fields (continued)

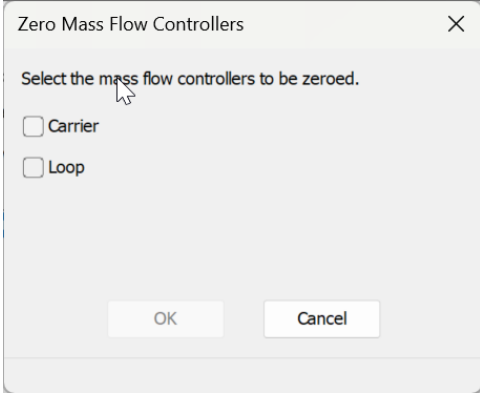
Selections	Description
Zero Mass Flow Controllers	 <p>When this step is executed, all gas inlet valves for each selected MFC will be closed and zeroed.</p>



For fields and buttons not listed in this table, see [Common Fields and Buttons on page 2 - 5](#).

METHODS

File > Open > [.MTH File]

Options > Default Method

A *Method* determines the default sample identification format and sequence number. A *Method* is a template of specifications that go into a newly created sample file. It allows for the definition of complete sets of parameters for each type of sample commonly analyzed. Only a single selection is required for each new sample file created.

File > Open > [.MTH File]

Options > Default Method

Methods

Selections	Description
Active Metals [<i>button</i>]	Opens the Active Metals dialog box that contains a list of active metals. See Active Metals for Chemisorption Analyzers on page 3 - 6 .
Comments [<i>text box</i>]	Enter comments to display in the report header about the sample or analysis.

Methods (continued)

Selections	Description
Mass [<i>group box</i>]	<p>Specify the default data.</p> <p>Enter. Enables the <i>Sample mass</i> field. Enter a value for the sample mass.</p> <p>Calculate. Enables the <i>Empty tube</i> and <i>Sample + tube</i> fields. Enter the values necessary to calculate the sample mass. The equation used to calculate sample mass:</p> $Mass_{sample} = Mass_{sample+tube} - Mass_{tube}$
Sample file name [<i>text box</i>]	<p>Enter a format for the sample identification. The entry in this field becomes a part of the saved sample file name. Include the \$ symbol to have the sample file number included as part of the identification.</p>
Field names [<i>text box</i>]	<p>Enter a name to use in the new sample file. A maximum of four fields can be configured. Default fields are Sample, Operator, Submitter and Bar Code.</p> <p>Check Omit to remove the field from the template. The first field cannot be omitted.</p>
Sequence Number [<i>text box</i>]	<p>Specify a default numeric string to use as a prefix in the <i>Sample</i> field when a new sample file is created. Select <i>Use separate sequence number</i> to specify a number other than the default.</p>
Use separate sample file directory [<i>text box</i>]	<p>Specify the directory to save the sample file other than the default shown. If the directory does not exist, the field is highlighted and an error message displays. Click the Browse button and select an existing directory.</p>
<div style="border: 1px solid green; padding: 5px;">  <p>For fields and buttons not listed in this table, see Common Fields and Buttons on page 2 - 5.</p> </div>	

REPORT OPTIONS

File > Open > [.RPO File]

Or, click the *Report Options* tab when in *Advanced* option presentation.

The *Calculations* document can be found on the Micromeritics web page (www.micromeritics.com).

Additional reports are available using the *Reports* menu.



Use to specify report options for data collected from an analysis or manually entered data. *Report Options* files also help in customizing report details such as axis scale, axis range, column headings, and components of thickness curve equations. These files may contain tabular reports, plots, or both, as well as advanced report tables.

Customized report options files can be created then loaded into a sample file, allowing quick generation of reports.

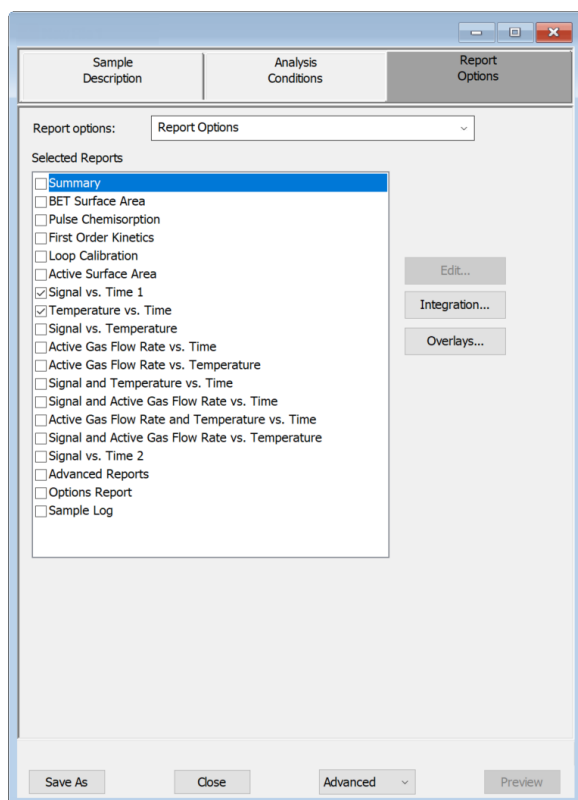
Report Options files may be defined to include overlay options. This system allows the overlay of up to 25 plots of different samples onto a plot of the same type or overlay one plot type onto a different plot type from the same analysis.

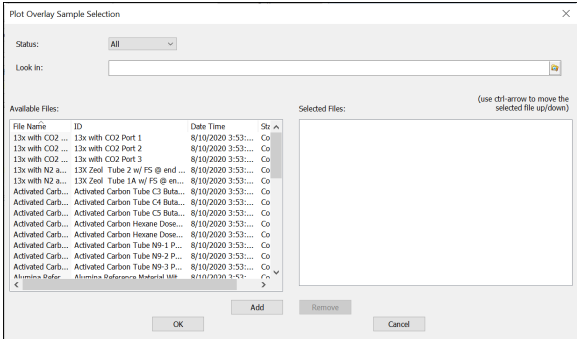

Report Options

Selections	Description
Edit [button]	Select the report in the Selected Reports box. See Selected Reports on page 7 - 1 .
Integration [button]	See Peak Detection / Integration Options on page D - 1
Overlays [button]	<p>Select the files to overlay.</p>  <p style="text-align: center;">Example of Overlay window</p>
Report Options [drop-down box]	Browse for a .RPO file that contains report options parameters to be used in the report.
Selected Reports [group box]	Select the report names to include in the report.
Show graphic [check box]	<p>Use to show a graphic on the report header.</p> <p>Height/Width. Enter the height and width of the selected graphic. These values determine the graphic's appearance on the generated report.</p>
Show report title [check box]	Select then enter a report title to appear on the report header.
 <p>For fields and buttons not listed in this table, see Common Fields and Buttons on page 2 - 5.</p>	

5 PERFORM AN ANALYSIS

ANALYSIS TEMPERATURE GUIDELINES FOR ALL ANALYSIS TYPES

- **Starting Temperature.** Experiments should be started at a temperature that is lower than that at which the reaction begins. If the reaction begins below ambient temperature, use the optional CryoCooler.
- **Maximum Temperature.** The experiment's maximum temperature is limited to the temperature at which the sample sinters.
- **Ramp Rate.** The recommended ramp rate is 5-10 °C/min, however a different ramp rate can be specified. For example, if using 500 °C as the starting temperature of the reaction, it is more expedient to ramp the temperature rapidly (for example, 50 °C/min.) to a value near 500 °C, then proceed with the experiment at 5-10 °C/min.

COOLING OPTIONS

The furnace must cool during temperature programmed analyses if:

- a low temperature is required as part of the analysis, or
- to speed cooling of the furnace to increase sample throughput or reduce analysis time.

If cooling is required for the analysis, a CryoCooler may be necessary. Cooling options are:

- **Allow the temperature to return to ambient over time.** If time is not a consideration, allow the furnace to cool over time. It may take two hours or more for the furnace to cool from 1000 °C to near ambient. This may be acceptable when time is not limited.
- **Promote cooling by manually opening the furnace.** The furnace cools more rapidly when it is open. This option requires the availability of an operator to open and close the furnace at the appropriate times during analysis.



When it has been used recently, the furnace and/or the sample tube may be hot. Use the cotton gloves provided in the accessory kit when handling heated surfaces. These cotton gloves are not intended to protect hands when heated surfaces are above 60 °C.

- **Connect a cooling gas or cryogen flow to the inlet on the front of the furnace.** A cooling flow of an appropriate gas or cryogen can be connected to the inlet on the furnace. Read the warning listed above. This option can provide rapid cooling of the sample but offers no control of the target temperature or the speed at which it is achieved. The gas or cryogen must be non-reactive — such as nitrogen, air, helium, argon, liquid nitrogen, or liquid argon.
- **Connect the optional CryoCooler to the inlet in the front of the furnace.** The CryoCooler provides control of the sample temperature to temperatures as low as -100 °C. The CryoCooler is required for accurate analyses that include signal recording below ambient. The CryoCooler Operator Manual can be found on the Micromeritics web page (www.micromeritics.com).

DEWAR PRECAUTIONS



Always handle glass Dewars with care. Any product incorporating a vacuum is a potential safety hazard and should be treated with caution. If in doubt, contact your safety officer.



Improper handling, disposal, or transportation of potentially hazardous materials can result in serious injury or damage to the instrument. Always consult the SDS when working with hazardous substances. Safe operation and handling of the instrument, supplies, and accessories are the responsibility of the operator.



Do not pour liquid nitrogen directly into a sink. Doing so may cause drain pipes to burst.

When handling Dewars containing liquefied gases or cryogenic liquids:

- Wear protective equipment:
 - goggles or face shield
 - an insulated or rubber apron
 - insulated gloves
- When pouring liquefied gases from one container to another:
 - cool the receiving container gradually to minimize thermal shock
 - pour the liquified gas slowly to prevent splashing
 - vent the receiving container to the atmosphere

FOR GLASS DEWARS

- Use a plastic stirring rod when stirring substances in a Dewar containing liquefied gases (or other materials of extremely low temperature). Do not use a glass or metal stirring rod unless it has a protective coating.
- Do not handle heavy objects above the Dewar. If unavoidable, place a protective cover over the Dewar opening. If an object of sufficient weight is accidentally dropped into the Dewar, shattering may occur.
- If the Dewar has a protective mesh covering, do not remove it. This cover minimizes the risk of flying particles should the Dewar be knocked over, dropped, or broken.

MIXING AN IPA/LN₂ SLURRY



An isopropyl alcohol (IPA) /liquid nitrogen (LN₂) slurry is used to maintain cold trap temperatures of approximately -80 °C. Improperly mixing an IPA/LN₂ slurry could cause injury. If the mixture is not stirred continuously, gas may build up under the surface, causing the liquids to splash out of the Dewar.

1. Chill a 600 mL Dewar by rinsing it with LN₂. Allow a small amount of LN₂ to remain in the bottom of the Dewar (approximately 1 cm deep).
2. Stirring constantly, slowly add approximately 500 mL of IPA. For greatest safety, use a laboratory squirt bottle. Squirt the stream of IPA along the inside edge of the Dewar, close to the top of the Dewar, allowing the IPA to flow down the inside wall of the Dewar. Do not stop stirring the mixture in the bottom of the Dewar, even if stirring becomes difficult. As stirring and adding IPA continues, the mixture will loosen and become easier to stir.
3. When all the IPA has been placed in the Dewar, slowly begin pouring LN₂ into the Dewar. Approximately 1 liter is needed. Continue to stir the mixture as LN₂ is added. As ice chunks form, break them up and stir them down into the mixture. Avoid splashing. Gently knock ice chunks away from the sides of the Dewar and continue stirring. Add liquid nitrogen until the slurry is within 25 mm (1 in.) of the top of the Dewar.
4. Lift the stirrer out of the slurry and observe as the slurry drips into the Dewar; the stirrer should be thickly coated with slurry.

The goal is to achieve a slurry that has a thick, syrupy consistency without large chunks. When the slurry is cold enough, small pieces of ice may be present (10 - 20% of the mixture). A little ice accumulation along the sides of the Dewar is acceptable.

PROTECT DETECTOR FILAMENTS BY FLOWING GAS



A carrier gas must be flowing through the detector whenever the detector filaments are turned on; otherwise, the filaments will deteriorate and lose sensitivity. If the gases are shut off, the filaments are automatically turned off after five minutes.

The flowing gas also continuously cleans the plumbing of any water vapor which can enter when the sample tube is removed. Ten cm³/min is sufficient to perform this function.

PREPARE FOR ANALYSIS

It is recommended to perform the tasks in the provided order.

CLEAN AND LABEL SAMPLE TUBES



The equipment images in this topic may differ slightly from your equipment; however, the instructions are the same unless otherwise noted.

Sample tubes and filler rods must be clean and dry before samples are added and weighed. The following table indicates which materials are needed for cleaning. The procedures following the materials list are recommended.

Supplied by Micromeritics	Supplied by User
<ul style="list-style-type: none"> ■ Funnel ■ Sample data worksheet ■ Sample tube ■ Sample tube brush ■ Sample tube rack ■ Sample weighing support ■ Stopper for sample tube 	<ul style="list-style-type: none"> ■ Acetone or isopropyl alcohol ■ Analytical balance ■ Detergent (such as Alconox) ■ Drying oven ■ Forceps ■ Insulated gloves ■ Pipe cleaners ■ Rubber gloves or clean, lint-free cloth ■ Safety glasses ■ Ultrasonic cleaning unit ■ Waste container

1. Preheat drying oven to 110 °C.
2. Verify that the ultrasonic cleaning unit is clean.
3. Use 5 grams of Alconox (or other suitable detergent) per 500 mL of warm water and fill the ultrasonic unit with enough water to cover the sample tubes and filler rods (if used). If too much detergent is used, it may be difficult to rinse from the sample tubes. Ensure the detergent is dissolved before placing the sample tubes and filler rods into the water.
4. Fill the sample tubes with warm water and place them in the ultrasonic cleaning unit, then place the filler rods in the unit. Turn on the ultrasonic cleaning unit for approximately 15 minutes.



5. Use rubber gloves to ensure no oils or residue are transferred to the clean tubes and filler rods, then remove the sample tubes and filler rods from the unit.
6. Clean the interior of the sample tubes with the brush supplied with the analyzer.
7. Rinse the sample tubes and filler rods thoroughly with hot water. Rinse again with isopropyl alcohol or acetone. If isopropyl alcohol or acetone is not available, deionized water may be used.



8. Stand the sample tubes on the sample tube rack and place the filler rods in a basket or in the rack. Bake in a vacuum oven for two hours at 110 °C.



Samples tubes can also be cleaned with high-purity acetone or isopropyl alcohol and dried for about 10 minutes under heat. If using this method, continue with step 10.

9. Remove the sample tubes and filler rods from the oven and allow to cool.



Do not insert the filler rods at this time. Filler rods are inserted before the sample tube is installed on the analysis port.

10. Blow out the sample tubes with oil-free compressed air.
11. Rinse the sample tube closure with isopropyl alcohol, then wipe the sample tube closure dry with a clean, lint-free cloth.
12. Label the sample tube and stopper for identification.
13. Replace the rubber stopper.

PREPARE THE SAMPLE

To obtain the most repeatable, accurate results:

- Use approximately the same amount of sample for each analysis (especially if data are compared sample to sample).
- Ensure the sample is well dispersed in the tube, not against the side or walls of the tube.
- Ensure the sample particle size distribution remains fairly constant from sample to sample. (Large particles of a substance reduce at a different rate than small particles of the same substance.) For samples with a wide particle size distribution, care should be taken that each sample is representative of the entire lot's distribution.

Micromeritics recommends analyzing samples weighing between 20 mg and 2 g. When determining a sample amount, consider that the sample must be contained within the bottom 20 mm (3/4 in.) of the sample tube.

When determining sample size, consider the percentage of active metals in the sample. Materials with lower percentages of active metals may require larger sample amounts for analysis, while materials with high percentages of active metals can be analyzed using smaller samples.



Larger amounts of very fine powders may become packed in the sample tube and block gas flow. The resulting increase in gas pressure may force some of the sample out of the sample tube, causing contamination of, or damage to the analyzer. A possible solution is to expand the sample bed with quartz wool.

CREATE THE SAMPLE FILE

[Create Sample Files on page 3 - 2](#)

DETERMINE THE SAMPLE MASS FOR CHEMISORPTION

[Use Quartz Filter Discs for Chemisorption on page 5 - 10](#)

[Sample Data Worksheet on page F - 4](#)



Bulb sample tubes are for pellets and other samples without loose particles. Using powder samples in bulb tubes may cause the loose particles to go into the analyzer's exhaust.



The equipment images in this topic may differ slightly from your equipment; however, the instructions are the same unless otherwise noted.

1. Record the sample tube identification on the *Sample Data Worksheet*.
2. Place the sample weighing support on the balance. Tare the balance and allow it to stabilize at zero.
3. If analyzing a powder or sample made of fine particles, push a piece of quartz wool all the way down into the sample tube.
4. If using *quartz wool*, put a second piece of quartz wool just inside the sample tube. If using *filter discs*, push a filter disc down into the tube until it sits on top of the quartz wool. Place a second filter disc just inside the sample tube.
5. Place the sample tube set (sample tube with quartz wool or filter discs and stoppers) on the sample support. Record the stabilized mass on the *Sample Data Worksheet*.



6. Remove the sample weighing support and sample tube set from the balance.
7. Place the sample container on the balance and allow the balance to stabilize at zero.



Do not touch the sample with bare hands. Oil from hands could affect the accuracy of results.

8. Slowly add approximately 0.5 to 1.0 gram of sample to the sample container.
9. If a second piece of quartz wool or filter disc was inserted, remove the top portion of the quartz wool or the filter disc from the sample tube.
10. Use a funnel to slowly pour sample from the container into the sample tube on top of the quartz wool in the tube.



Ensure all sample in the container is placed in the sample tube to avoid errors caused by incorrect sample mass.

11. If using *quartz wool*, insert the top portion of quartz wool into the tube and press it down. If using *filter discs*, insert the filter disc into the tube and press it down.



Ensure the disc is flat on top of the sample. A seal must be created around the edge to prevent the sample from escaping.

12. Wipe the top of the sample tube with a clean, lint-free cloth, such as a Kimwipe®, to remove any quartz wool that may have adhered to the surface.
13. Weigh the sample tube set containing the sample and the stoppers. Record this mass as the *Sample + tube*.

Use Quartz Filter Discs for Chemisorption



The equipment images in this topic may differ slightly from your equipment; however, the instructions are the same unless otherwise noted.



The use of quartz wool is not mandatory; however, it can provide extra protection for light powdered samples.



Wear latex gloves when handling the quartz sample tube. The natural oils in human skin can chemically damage and weaken the quartz tube. It is also important that the sample tube and its components, as well as the sample and exhaust ports, be clean and free of debris. Dust particles from quartz wool or the insulator disc of previous analyses may adhere to the port and/or components, preventing a proper seal of the sample tube.

Use quartz filter discs or quartz wool to aid in chemisorption sample preparation. Quartz filter discs (placed both below and above powdered samples) not only provide a more uniform sample surface but also keep the analyzer free of sample debris. The filters can be used up to 900 °C.

1. Insert a small portion of quartz wool into the sample tube to serve as a support for the powdered sample. Use a filler rod or smaller sample tube to push the quartz wool to the bottom of the sample tube.

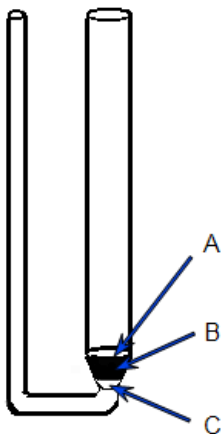

- A. Quartz disc
- B. Sample
- C. Quartz disc and quartz wool

2. Insert a quartz disc into the sample tube and push it into the tube until it rests on top of the quartz wool. Inspect the disc to ensure that there is a good seal and that the sample will not go past the filter. An additional filter can be inserted if needed.

3. Insert a second filter disc on top of the quartz wool. Ensure that the filter is placed high enough into the sample tube for easy retrieval.
4. Take the initial tube weight (with both filters).
5. Remove the top filter disc. Place it on a clean surface, then use a funnel to add the powdered sample on the bottom filter disc.
6. Reinsert the top filter disc into the sample tube, then use a rod or smaller sample tube to push it down until it reaches the top of the sample.
7. To remove the quartz wool and disc after analysis, use the quartz wool extractor tool.

SAMPLE TUBE INSTALLATION

[Sample Tube on page 8-15](#)

FILL AND INSTALL THE DEWAR

[Dewar Precautions on page 5 - 3](#)

[Check and Clean the Dewar on page 9-14](#)

To surround the cold trap, the Dewar must rest on a small stand. Hold the Dewar beneath the cold trap, then raise it enough to slide the stand underneath the Dewar. Lower the Dewar until it rests on the stand. Ensure the cold trap is immersed.

If performing an analysis that requires use of the cold trap and cryogen, check the cryogen level in the Dewar. It should be approximately 25 mm (1 in.) from the top.



The cryogen must not be cold enough to trap the carrier gas or analysis gas. Do not use liquid nitrogen with argon carrier gas. For example, use an alcohol and liquid nitrogen slurry (-80 °C).

PERFORM A PULSE CHEMISORPTION ANALYSIS

[Pulse Chemisorption Analysis Tutorial on page 11 - 15](#)



When running an analysis and a CryoCooler is connected to the analyzer, a warning displays indicating that the Dewar level should be full before running an analysis.



This topic provides an example of Pulse chemisorption being performed on a sample of Pt/Al₂O₃ with CO. Make the appropriate modifications for the material being analyzed. Platinum Alumina Reference Material can be ordered from Micromeritics. Parts and accessories are located on the [Micromeritics](#) web page.

A Pulse chemisorption analysis determines the quantity of active gas irreversibly adsorbed. By applying pulses of known quantity of active gas to the sample, calculations of active surface area, percent metal dispersion, and active particle size can be made for supported metals. The sample is dosed with the analysis gas using the injection loop or a syringe until all accessible active sites are covered. The amount chemisorbed is the difference between the total amount of active gas injected and the amount that does not interact irreversibly with the sample.

The number of injections depends on the quantity in each pulse and total number of active sites present.

LOOP VOLUME

[Loop Volume Calibration Analysis Tutorial on page 11 - 14](#)

The gas quantity in each pulse is determined by active gas concentration, the loop or syringe volume, temperature, and pressure. The loop temperature is controlled by the instrument. The ambient (syringe) temperature and atmospheric pressure are entered by the operator. If a syringe is used, the volume injected is determined by the operator. In general, it is desirable for the sample to require at least two doses of gas, but no more than ten doses, before the reaction ends (although this may vary from lab to lab). Some factors that influence the number of doses required are sample size, the density of active sites, the concentration of active gas, and the size of the loop.

A 0.5 cm³ loop is provided with the analyzer. There are also 1 cm³ and 5 cm³ loops available.

LOOP CALIBRATION

[Loop Calibration for TCD Analyzers Tutorial on page 11 - 11](#)

[Loop Volume Calibration Analysis Tutorial on page 11 - 14](#)

For the most accurate determination of the injected gas quantity, a loop calibration experiment should be performed. An independent loop calibration can be performed before or after the analysis.

The following example assumes that the loop calibration will be performed after the analysis. A *Loop Calibration* step can be included in a pulse chemisorption analysis.

Preparation	
Pretreatment	Degas by flowing inert gas (such as helium, argon, or nitrogen) over the sample while ramping the temperature. Hydrogen of at least 10% concentration is generally used for reduction.
Analysis	Pulse the loop gas over the sample until the peak area remains constant.
Sorption or Cold Trap	The trap does not need to be cooled during the reference material analysis. This may vary depending on application or analysis method. The trap tube should remain on the instrument. Including the trap in the flow path is optional.
Pressure regulator	Gas cylinders should be set to a level between 14 and 16 psig (95 and 110 kPag).
Furnace temperature	Select a temperature high enough to remove any contaminants or moisture, but not so high as to cause sintering or fusing of the sample. Ensure the <i>Termination</i> step is set to return the sample temperature to ambient.



Before performing an analysis, ensure the sample and analyzer are adequately prepared. See [Prepare for Analysis on page 5 - 5](#).

PROCEDURE

1. Obtain the sample mass, then install the loaded sample tube and thermocouple on the analyzer. Raise the furnace around the sample tube and install the insulator disc and shield.
2. Create a new sample file for this analysis. In the *Analysis Conditions* drop-down box, select either *Pt-AI CO Pulse Chemisorption Loop* or *Pt-AI CO Pulse Chemisorption Syringe* and modify the steps as needed depending on the analysis to be performed.
3. On the *Report Options* tab, select the required report options for the analysis.
4. Save and close the file.
5. Go to **Unit [n] > Sample Analysis** and select the sample file saved in the previous step.
6. Click **Start** to start the analysis.
7. When prompted, select the calibrations associated with each experiment in the sample file (if applicable). For this example, select *None*. Calibration files can also be associated with a sample file after analysis using the *Peak Editor*. See [Peak Editor on page 6 - 2](#).



When the analysis ends, the furnace begins to lower the sample temperature to room temperature. When the sample has cooled, open the furnace and remove the sample tube.



Use the cotton gloves provided in the accessory kit when handling heated surfaces. These cotton gloves are not intended to protect hands when heated surfaces are above 60 °C.

GENERATE THE REPORT

[Peak Editor on page 6 - 2](#)

Open the Peak Editor and ensure that peaks are properly marked.

There are three possibilities for each dose of gas injected during:

- all of the gas is taken up by the sample,
- some of the gas is taken up by the sample, or
- none of the gas is taken up by the sample.

When Pulse chemisorption is properly performed, there will be some injections of each type. When the data is viewed using the Peak Editor, however, only those injections in which some or none of the gas is taken up will appear as peaks. When all of the gas is taken up by the sample, none of it reaches the detector and, therefore, the peak area is zero. These types of peaks are detected automatically by the application and do not require marking.

To generate the report, go to **Reports > Start Report> [.SMP file created above]** or click **Preview** and select the signal view.

PERFORM A SAMPLE ANALYSIS

Unit [n] > Sample Analysis

[Analysis Tutorials on page 11 - 1](#)



When running an analysis and a CryoCooler is connected to the analyzer, a warning displays indicating that the Dewar level should be full before running an analysis.

1. From the menu bar, select **Unit [n] > Sample Analysis**.
2. Click **New** to create a new sample file, or click **Browse** to select an existing file.

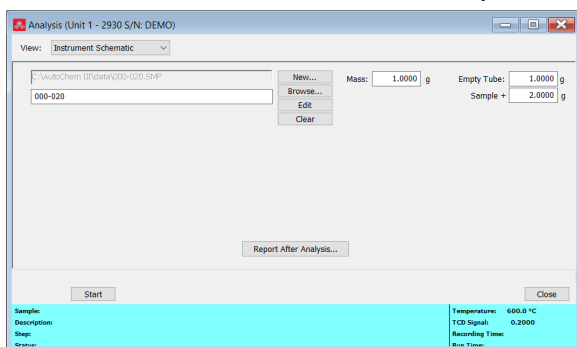

3. Edit the *Mass*, *Empty Tube*, and *Sample +* fields, as needed.
4. Click **Report After Analysis** and specify the settings for the generated report.

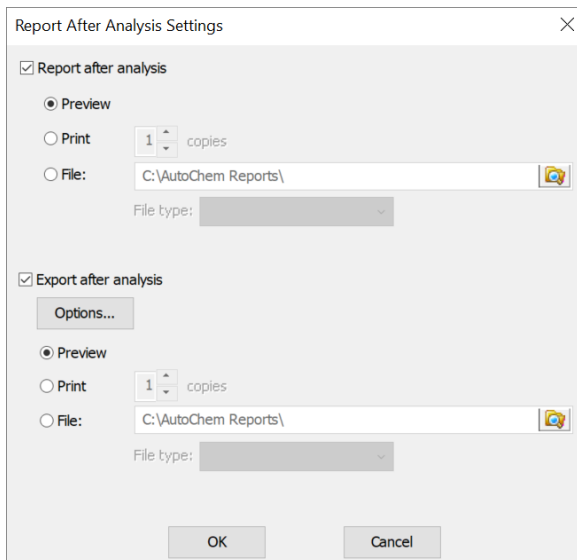

5. If applicable, click **Options** to select specific export options. See [Export Files on page 2 - 32](#). Then click **OK**.
6. Click and select a calibration file for each experiment.

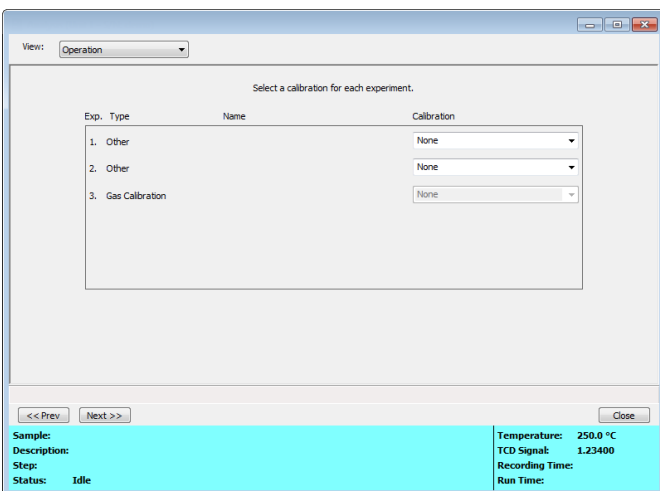

7. Click **Start** to begin the analysis.

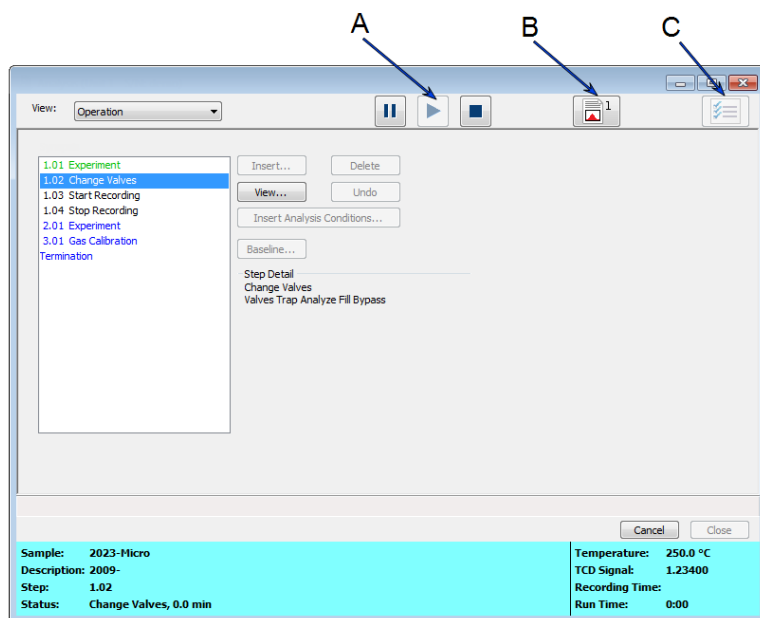

- A. Suspend/Resume/Skip buttons
- B. Port report buttons
- C. Live graph settings

The *Operation* view displays experiment steps and details as steps are performed. Text colors indicate the progress. Completed steps are shown in green. In progress steps are shown in light blue. Pending steps are shown in black, dark blue or dark green (depending on their nesting level).

8. To change steps that have not been started:
 - Click **Suspend**, select the step, then click the appropriate button for modification.
 - Click **Resume** to continue the analysis.

9. Select the **Results** view to see the analysis in progress.

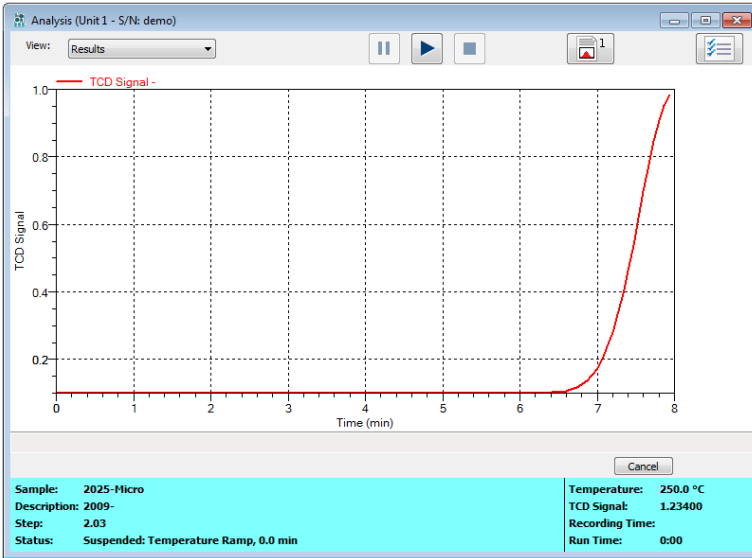

10. Click the **Live Graph Settings** button to hide or show different settings.

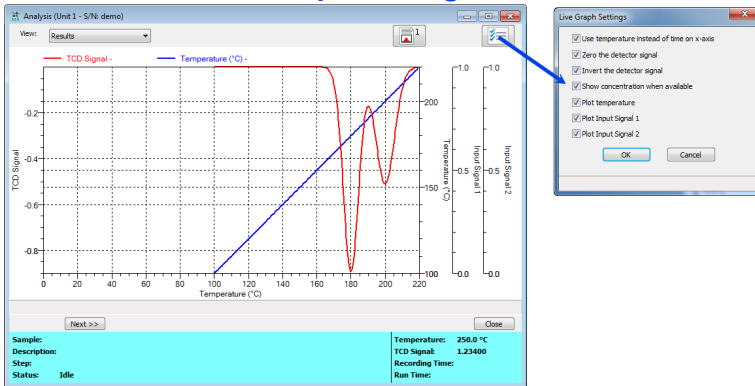

PERFORM A REFERENCE ANALYSIS

Unit [n] > Reference Analysis

[Analysis Tutorials on page 11 - 1](#)



When running an analysis and a CryoCooler is connected to the analyzer, a warning displays indicating that the Dewar level should be full before running an analysis.

1. Select the type of *View* from the drop-down list.
2. Select a *Method* from the drop-down list, or click **Browse** to select an existing file.
3. Edit the *Mass*, *Empty Tube*, and *Sample + Tube* fields, as needed.

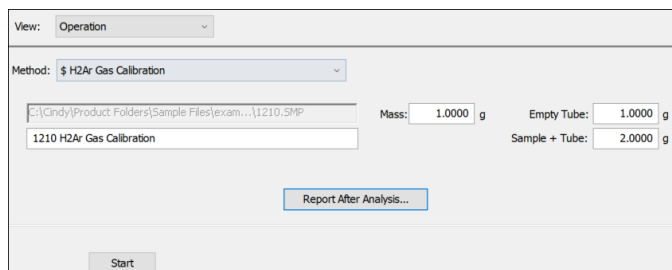

4. Click **Report After Analysis** and specify the settings for the generated report.

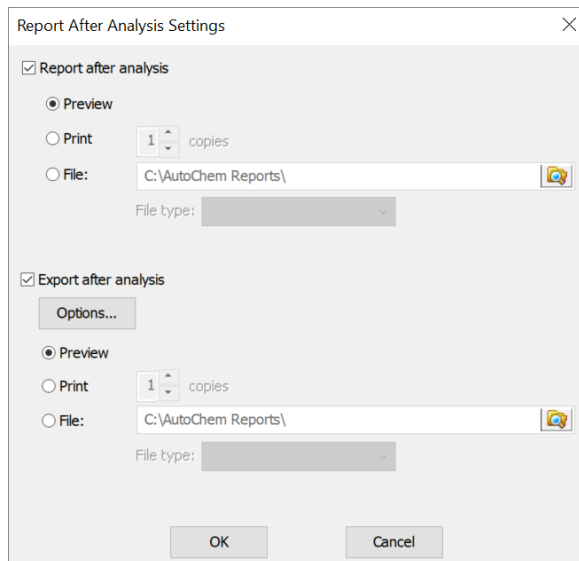

5. If applicable, click **Options** to select specific export options. See [Export Files on page 2 - 32](#). Then click **OK**.
6. Click **Start**. The sample file is created and set up automatically.

**This page
intentionally
left blank**

6 ABOUT REPORTS

Reports can be generated for data collected on a sample that has completed analysis, collected on a sample currently being analyzed, or manually entered.

Reports > Start Report

Generates a report on a sample analysis.

Reports > Close Reports

Closes all open reports. This option is unavailable if reports are being generated.

MICROACTIVE REPORTS

This feature provides a quick and easy way to investigate and manipulate analysis data using a variety of reporting methods.

When a sample file with a status of *Complete* or *Analyzing* is opened, plots of the data collected during analysis are displayed. Numerous reports, including the Peak Editor, are accessible from a drop-down menu.

When a report is opened, plots and summary data are displayed, and in some reports certain parameters are also displayed. Plots may be edited by selecting the data points or data point range to be included in the plots and modifying the parameters. When a report is edited, the results are immediately reflected in the plots and summary data.

PEAK EDITOR



Analysis condition defaults for metal stoichiometry factors can be set using the sample information metal table editor. Stoichiometry factors can also be set for each pulse chemisorption experiment using the analysis conditions experiment step editor. If required, stoichiometry factors for a completed pulse chemisorption experiment can be viewed and modified using the peak editor's stoichiometry settings window.

The *Peak Editor* feature provides the viewing and editing of up to 16 dynamic analysis experiments. The *Peak Editor* options are accessed by opening a Completed sample file and selecting a "Peak Editor" entry from the drop-down menu at the bottom of the report window. Peaks can be defined, edited, or deleted.

Peaks are defined by a baseline. If the **Find All Peaks** button is clicked (enabled when *Edit Peaks* is selected), the *Peak Editor* will define baselines for all positive peaks detected according to the *Integration* window accessed from the **Integration** button. For Loop calibrations, peaks are found using events that occurred during the analysis — such as the time an injection started — instead of peak detection options. The baseline can be manually defined by double left clicking in the signal graph on the starting baseline point (this places the Peak Editor into baseline creation mode). The ending baseline point is then defined by left clicking in the signal graph on the ending baseline point. Baseline creation mode can be exited by right clicking in the signal graph.

PEAK EDITOR VIEW

[Open a Sample File on page 3 - 5](#)

When a sample file with a *Complete* status is opened, three views are available:

- Overlay Experiments View
- Stacked Experiments View
- Peak Editor

To change the view, select the view from the drop-down list at the bottom of the graph window. Only the *Peak Editor* view allows editing of the experiment.

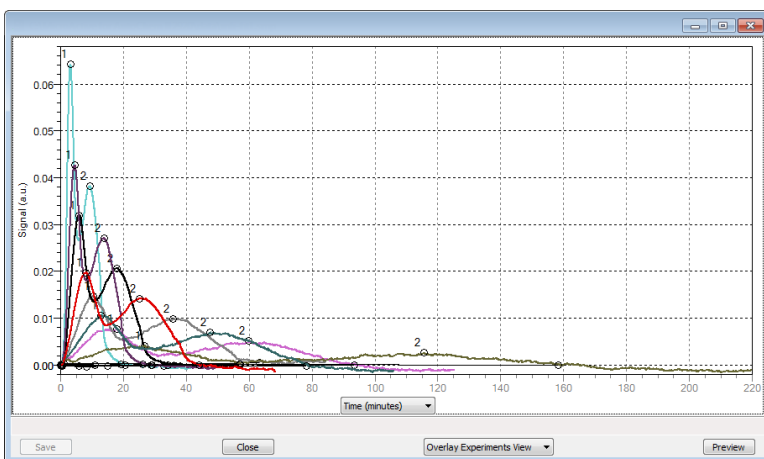

**Example of
Overlay Experiments view**

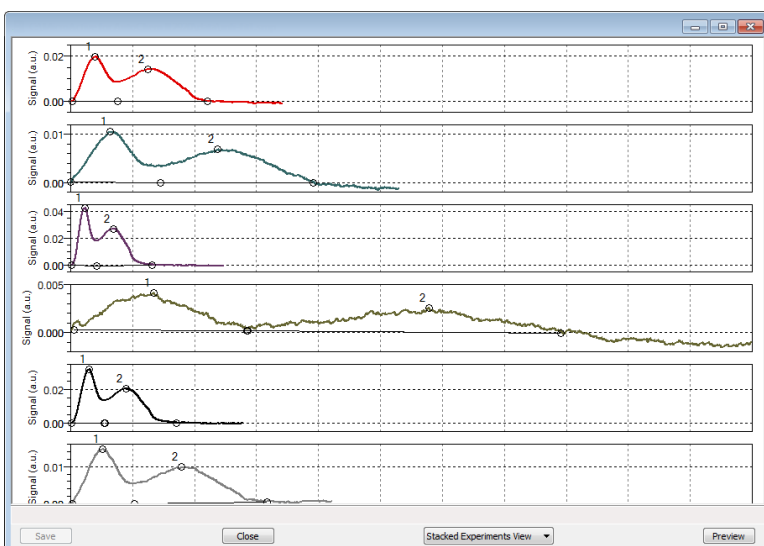

**Example of
Stacked Experiments view**

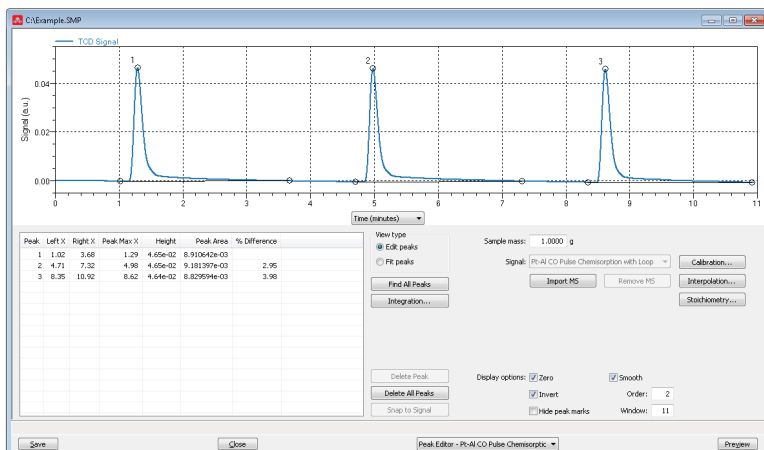

Example of
Peak Editor view

Peak Editor

Selections	Description
Calibration [button]	<p>Calibration. Select a previously defined calibration file. If the experiment and calibration gases differ, a warning displays. The system also compares the experiment flow rate and calibration flow rate. If they differ, a warning displays.</p> <p>Experiment Information</p> <ul style="list-style-type: none"> ■ Description. Enter a description of the current experiment. ■ Type of analysis. Select the analysis type that most closely describes the current experiment. This will affect what is reported as part of the Summary report data and the available reports. ■ Loop volume. Displays the volume of the gas injection loop.



Peak Editor (continued)

Selections	Description
	<ul style="list-style-type: none"> ▪ Ambient temperature. Displays the ambient temperature entry from the <i>Options > Environmental Defaults</i> setting. This field may be edited. ▪ Atmospheric pressure. Displays the atmospheric pressure entry from the <i>Options > Environmental Defaults</i> setting. This field may be edited. ▪ Active concentration. Displays the percent of the gas mixture which is composed of the reactive gas versus an inert filler. This value is used for data reduction, including pulse chemisorption. ▪ P₀ of adsorbate. Displays the saturation pressure of the adsorbate. ▪ Adsorbate cross-sectional area. Displays the area that a single adsorbed molecule occupies on the surface of the sample. It is used in surface area calculations. ▪ Manual Injections. Displays the injection settings entered during analysis. This table may be edited. <p>Create Calibration. Create a signal calibration from the currently selected experiment.</p>
Delete [button]	<p>Clears all peaks from the table and removes all markings from the peaks.</p> <p>To delete a single peak, select the peak from the peak table or left click the peak to enable the Delete Peak button.</p> <ul style="list-style-type: none"> ▪ Delete All Peaks is available only when the <i>Edit Peaks</i> selection is enabled. ▪ Delete Peak is available only when the <i>Fit Peaks</i> selection is enabled.
Delete Baseline [button]	<p>Removes the baseline from the graph.</p> <p>Available only when the <i>Fit Peaks</i> selection is enabled.</p>
Display Options [group box]	<p>Use to change how the data are displayed.</p> <p>Zero. Select to zero the signal (starting baseline).</p> <p>Invert. Select to invert the signal (peak).</p> <p>Hide Peak Marks. Select to hide all marks from peaks.</p> <p>Smooth. Select to smooth the signal on the display.</p> <ul style="list-style-type: none"> ▪ Order and Window. Enabled when the <i>Smooth</i> checkbox is selected. The smoothing process uses the Savitzky-Golay filter to fit a polynomial order <i>n</i> into size of the specified window [<i>m</i>].
Find All Peaks [button]	<p>Defines baselines for all positive peaks detected according to the <i>Integration</i> window, accessed via the Integration button.</p>

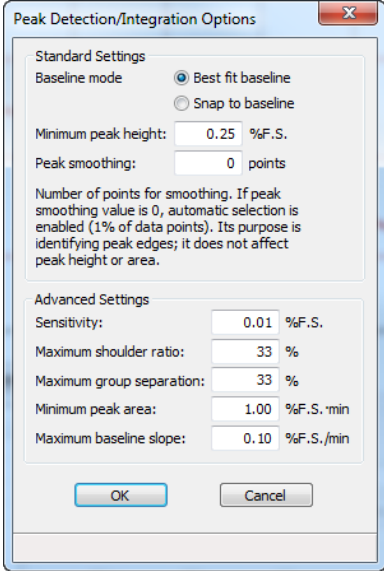
Peak Editor (continued)

Selections	Description
	<p>Find All Peaks automatically detects the peaks and draws the baseline for detection. Place the cursor over one of the baseline end points and double left click to grab the baseline. Move the cursor to the new position and right click. Available only when the <i>Edit Peak</i> selection is enabled.</p>
<p>Gaussian [drop-down box]</p>	<p>Standard Gaussian curve. Available only when the <i>Fit Peaks</i> selection is enabled.</p>
<p>Import M.S. [button] Remove M.S. [button]</p>	<p>Mass spectrometer data can be imported and overlaid in the <i>Overlay Experiment</i> view. In the <i>Peak Editor</i> view, it is saved as a separate signal.</p> <p>Import M.S. Click to import mass spectrometer data. In the bottom right-hand corner of the pop-up window, select the type of mass spectrometer file to import (Quadera, Quadstar, MKS, or TAMS). Select the file, then click Open to import the signals.</p> <p>A popup window prompts the user to sync the temperature data with the current experiment temperature data.</p> <p>Remove M.S. Click to remove all previously imported mass spectrometer signals from the current experiment.</p>
<p>Import standard peaks [button]</p>	<p>Imports the saved peak parameters from the <i>Edit Peaks</i> view. Available only when the <i>Fit Peaks</i> selection is enabled.</p>
<p>Integration Options [button]</p>	 <p>See Peak Detection / Integration Options on page D - 1.</p>
<p>Interpolation [button]</p>	<p>Interpolate Temperature. Select to interpolate the temperature. Click</p>

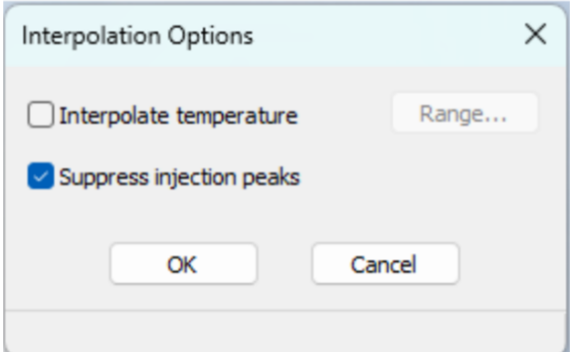
Peak Editor (continued)

Selections	Description
	<p>Range to specify a temperature range. Slide the blue bars on the graph to indicate the range.</p> <p>Suppress injection peaks. Select to remove injection artifact spikes from the TCD signal during <i>Loop Calibrations</i> and <i>Dose</i> steps. The signal is linearly interpolated during a short time interval after the start and end of each injection.</p> 
Log Normal Skewed [button]	A 4-parameter, log-normal shape that allows for skewed peaks. This is the default peak. Available only when the <i>Fit Peaks</i> selection is enabled.
Peak fit model [button]	Select the peak shape. Available only when the <i>Fit Peaks</i> selection is enabled. Options include: Gaussian, Lorentzian, Pearson type VII, Pseudo-Voigt, and Log Normal Skewed (3 and 4).
Sample mass [text box]	Calculates the mass-specific quantities. Initial value is taken from the sample information at the start of the analysis.
Snap to Signal [button]	Places the selected baseline point on the signal curve.
Stoichiometry [button]	See Active Metals for Chemisorption Analyzers on page 3 - 6 .
View Type [group box]	<p>Edit Peak. Locates peaks via signal integration over a baseline.</p> <p>Fit Peaks. Locates peaks via function fitting to minimize residual over a baseline.</p>
 <p>For fields and buttons not listed in this table, see Common Fields and Buttons on page 2 - 5.</p>	

SPC REPORT

Reports > Open SPC Report

Use to generate reports with various *SPC* (Statistical Process Control) options. All selected variables must be computed for each sample file used in an SPC report; therefore, it is more efficient to select only the necessary variables.

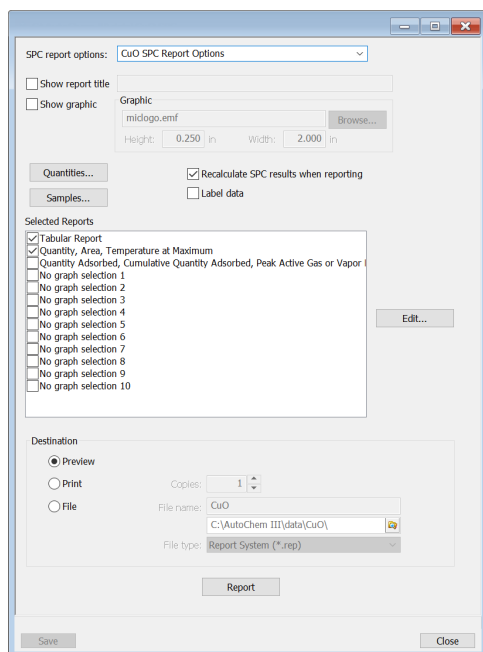

REPORT FEATURES / SHORTCUTS

[Report Style on page 2 - 34](#)

Click **Preview** on the MicroActive report window to display additional report information.

- After analysis, reports can be viewed, printed, and/or copied and pasted into other documents.
- The report zoom feature provides the viewing of fine graph details and the ability to shift the axes.
- All reports contain a header displaying file statistics.
- Tabular and graphical reports contain sample and analyzer statistics such as analysis date/-time, analysis conditions, etc.
- The headers contain notes of sample file changes occurring after analysis.
- Summary report headers contain the same information as tabular and graphical reports with the exception of notes.

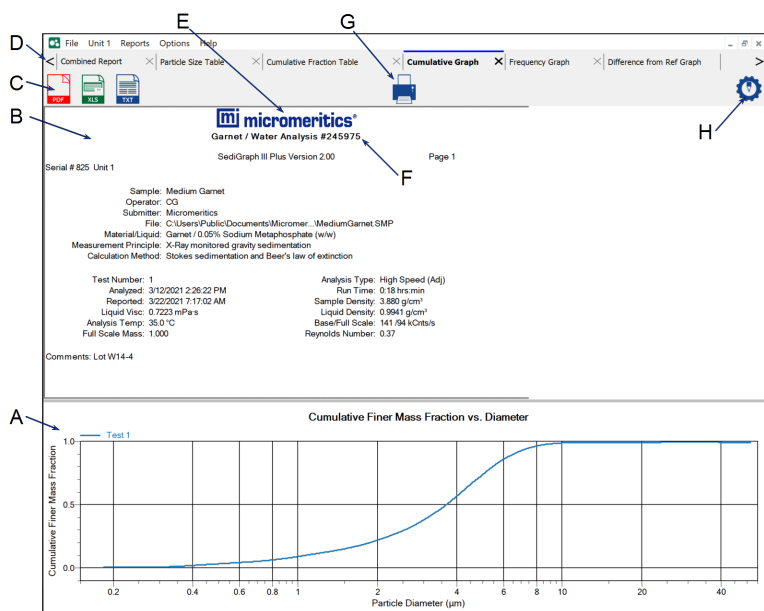

- A. Data display (graph or text)
- B. Report header area
- C. Report export options
- D. Generated tabs
- E. Report graphic
- F. Title
- G. Print icon
- H. Style icon

Report Features and Shortcuts

Selections	Description
Data Display area	Displays either a graphic or text from the generated report. Click the tabs across the top to display the selected report.
Generated tabs	Tabs represent the reports selected on the <i>Report Options</i> window.
Print icon	Click to send the report to a designated printer.
Report export options	Select a file format option for the exported report details.

Report Features and Shortcuts (continued)

Selections	Description
Report graphic	A graphic can be displayed on the report by using the Style button.
Report header area	Displays information about the sample, instrument, and software.
Title	A report title can be displayed on the report by using the Style button.
Style icon	Click to customize report options, such as font size, graphics, report title, etc.

REPORT SHORTCUTS

Right-click in the graphic or tabular report area to display report shortcuts.

Report Shortcuts

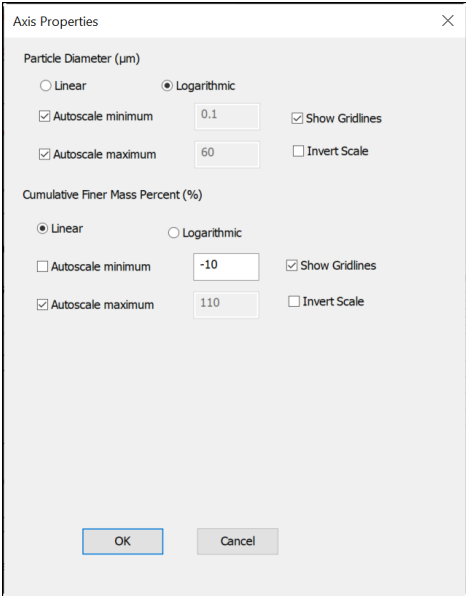
Selections	Description
Autoscale all axes	Returns the report to full view after using the zoom feature.
Copy data	Copies the report data to the clipboard. It can then be pasted into other software programs as tab-delimited columns or copied as an overlay onto another graph.
Copy plot	Copies the graph to the clipboard. It can then be pasted into other software programs.
Copy table	Copies the table to the clipboard.
Edit curve	Edits available curves from the report.
Reset axis limits to initial setting	Removes the cross-hair and returns the graph back to the initial setting.
Set scaling options	<p>Edits the axis properties.</p>  <p>Linear / Logarithmic. <i>[button]</i> Select the option to scale the graph as linear or logarithmic.</p> <p>Autoscale minimum / maximum. <i>[checkbox]</i> To manually specify minimum / maximum autoscale, deselect the option and enter the new amount in the text box.</p>

Report Shortcuts (continued)

Selections	Description
	Show Gridlines. [<i>check box</i>] Use to enable or disable report gridlines. Invert scale. [<i>check box</i>] Use to invert the scale.
Show curve	Displays a list of all curves. Select the curve(s) to display.
Show legend	Displays or hides the legend.

GRAPH FEATURES AND SHORTCUTS

Right-click in the graph area to display graph report shortcuts.

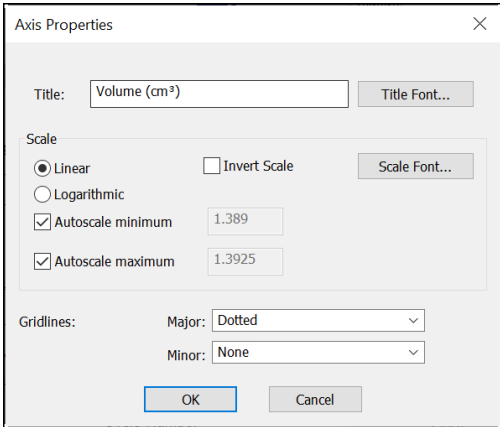

Graph Shortcut Options

Selections	Description
Autoscale all axes	Returns the report to full view after using the zoom feature.
Copy graph	Copies the graph to the clipboard. It can then be pasted into other software programs.
Copy plot	Copies the plot onto the clipboard. It can then be pasted into other software programs.
Edit axis	<p>Edits the selected axis properties.</p>  <p>Gridlines. Changes how to display major / minor grid lines.</p> <p>Scale.</p> <ul style="list-style-type: none"> ▪ Autoscale minimum/maximum. To manually specify minimum / maximum autoscale, deselect the option and enter the new amount in the text box. ▪ Invert scale. Inverts the scale. ▪ Linear/Logarithmic. Scales the graph as linear or logarithmic. ▪ Scale font. Modifies the font for the scale label. Deselect <i>Use default font</i> to enable font options. <p>Title. Edits the selected axis label.</p> <p>Title font. Modifies the font for the selected axis label. Deselect <i>Use default font</i>. Select new font attributes for report data. Enable <i>Use default font</i> to reset default fonts.</p>

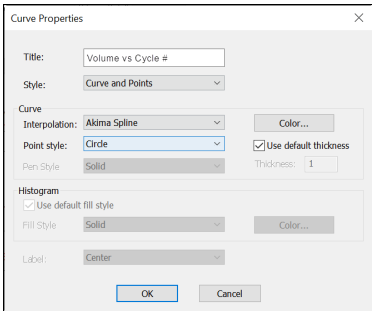
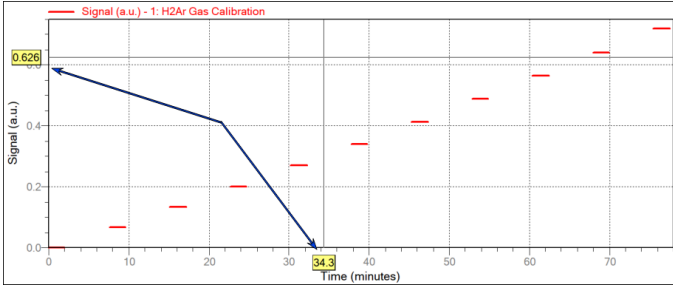
Graph Shortcut Options (continued)

Selections	Description
Edit curve	<p>Edits selected curve properties.</p>  <p>Color. Changes the curve color.</p> <p>Curve. Changes the interpolation, point style, and pen style for the selected curve. These options are disabled if <i>Use default fill style</i> is selected in the <i>Histogram</i> group box.</p> <p>Histogram. Enabled only if <i>Histogram</i> is selected in the <i>Style</i> drop-down list. Specifies the type of fill, fill color, and label position for the selected curve.</p> <p>Label. Designates where the graph point labels will display (left, right, center, etc.) on the SPC report.</p>  <p>Style. Selects another style for the collected data curve.</p> <p>Title. Changes the title of the selected curve.</p> <p>Use default thickness. Uses the default curve thickness. Deselect to enter a new thickness number in the <i>Thickness</i> text box.</p>

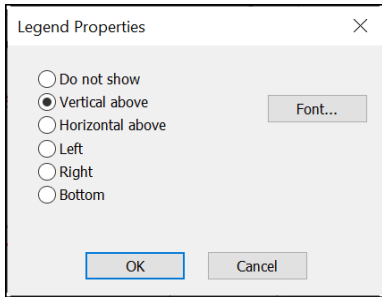
Graph Shortcut Options (continued)

Selections	Description
Edit legend	Changes the legend location and font. 
Edit title	Changes the report title.
Reset axis limits to initial setting	Removes the cross-hair and returns the graph back to the initial setting.
Show curve	Displays a list of all curves. Select the curve(s) to display.
 For fields and buttons not listed in this table, see Common Fields and Buttons on page 2 - 5 .	

AXIS CROSS-HAIR

Left-click on the graph to view the cross-hair coordinates.

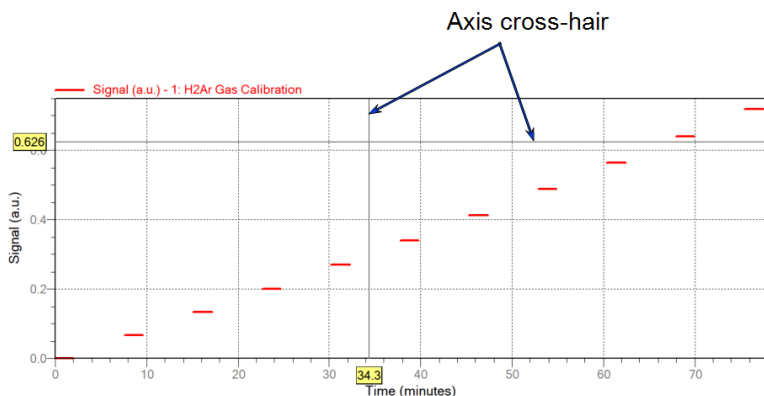

**Example of
Axis cross-hair feature**

ZOOM FEATURE

Use the zoom feature to examine graph details. Click, hold, and drag the left mouse button on the graphical area to be enlarged. A box will display in the area to be enlarged. To return to normal view, right-click in the graph and select *Autoscale all axes*.

GRAPH GRID LINES

Options > Graph Grid Lines

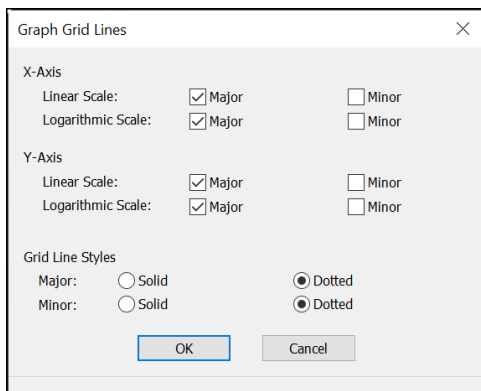

Use to select how grid lines appear on reports. This menu option is not available if using *Restricted* option presentation.

Graph Grid Lines

Selections	Description
Grid Line Styles [selection]	Select if the major and/or minor grid lines should appear as solid or dotted lines.
X-Axis / Y-Axis [selection]	Select major and/or minor lines to display in reports for the logarithmic and linear scales. Deselect this option to remove the grid lines.



For fields and buttons not listed in this table, see [Common Fields and Buttons on page 2 - 5](#).

REPORT EXAMPLES

PULSE CHEMISORPTION REPORT



AutoChem & Chemisorb Auto Version 2.00 AutoChem III Version 1.03 Page 2 of 6

Serial # 0001 Unit 1 Port 1

Sample: 0.5% Pt/Al₂O₃
 Operator: PV
 Submitter:
 File: C:\Users\Public\Documents\Micromeritics\AutoChem III\data\2730
 Perform_10.5%Pt-Al₂O₃_COHe_Run2.SMP

Started: 7/25/2025 8:31:19 AM Sample mass: 0.5508 g
 Completed: 7/25/2025 11:34:05 AM Report time: 10/13/2025 2:03:56 PM
 Instrument: 2730

Comments: Initial mass: 0.5898g
 Alter mass: 0.5508g
 Lot# 13378-6
 Specification: 31% +/- 5%

Pulse Chemisorption Report

Experiment 1 CO Pulse_0.5% Pt/Al₂O₃
 Analysis type: Pulse Chemisorption
 Calibration: None
 Measured flow rate: 50.00 cm³ STP/min
 Signal offset: 0.00000
 Signal inverted: Yes
 Number of Peaks Used for Saturation: 1

Peak Table			
Peak Number	Temperature at Maximum (°C)	Quantity Adsorbed (cm ³ /g STP)	Cumulative Quantity (cm ³ /g STP)
1	43.6	7.967e-02	7.967e-02
2	42.7	7.832e-02	0.15799
3	41.8	4.819e-02	0.20619
4	41.0	4.180e-03	0.21037
5	40.1	5.276e-04	0.21089
6	39.3	0.00000	0.21089

Pulse Chemisorption Analysis Summary

Element	Percent of Sample Mass (%)	Percent Reduced (%)	MixOy X	MixOy Y	AMU	Stoichiometry Factor	Atomic Cross-Sectional Area (nm ²)	Density (g/cm ³)
platinum	0.500	100.00	1	0	195.090	1.000	0.0800	21.450

Active loop volume at 35.3 °C: 0.04460 cm³ STP
 Cumulative quantity: 0.21089 cm³/g STP
 Metal dispersion: 36.7120 %
 Fractional coverage: 0.367120
 Metallic surface area: 0.4533 m²/g sample
 Metallic surface area: 80.6595 m²/g metal
 Crystallite size (hemisphere): 3.08503 nm
 Crystallite size (cube): 2.57116 nm

SIGNAL VS TEMPERATURE REPORT



AutoChem & ChemiSorb Auto Version 2.00 AutoChem III Version 1.03 Page 3 of 3

Serial # 0001 Unit 1 Port 1

Sample: CBV 3020 TPD with 8 Ramps
Operator: PK
Submitter:
File: C:\Users\Public\Documents\Micromeritics\AutoChem III\data\2730 Per... \ZSM-5 CBV 3020 Ammonia TPD SMP

Started: 7/17/2025 5:04:20 PM Sample mass: 0.0458 g
Completed: 7/19/2025 12:02:56 AM Report time: 10/10/2025 10:01:27 AM
Instrument: 2730

Comments: Initial mass: 0.0502g
After mass: 0.0458g

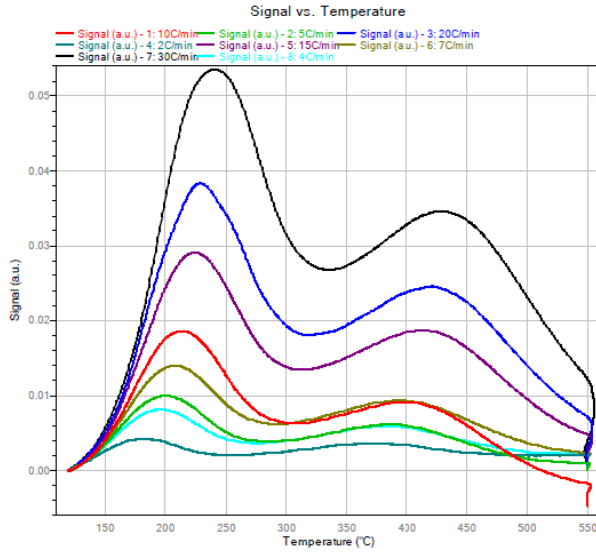

SIGNAL VS TIME REPORT



AutoChem & ChemiSorb Auto Version 2.00 AutoChem III Version 1.03 Page 1 of 3

Serial # 0001 Unit 1 Port 1

Sample: CBV 3020 TPD with 8 Ramps
Operator: PK
Submitter:
File: C:\Users\Public\Documents\Micromeritics\AutoChem III\data\2730 Per...ZSM-5 CBV 3020 Ammonia TPD.SMP

Started: 7/17/2025 5:04:20 PM Sample mass: 0.0458 g
Completed: 7/19/2025 12:02:58 AM Report time: 10/10/2025 10:01:27 AM
Instrument: 2730

Comments: Initial mass: 0.0502g
After mass: 0.0458g

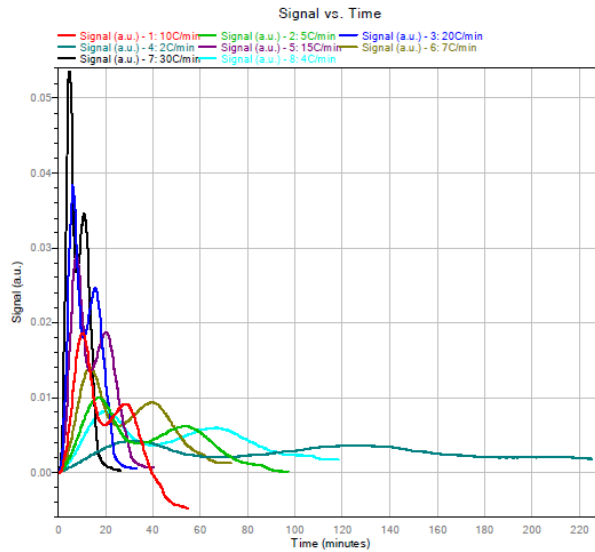

**This page
intentionally
left blank**

7 SELECTED REPORTS



To edit reports, open the *Sample* file then select the *Report Options* tab. Highlight the report name in the *Selected Reports* list box and click **Edit**.

ACTIVE SURFACE AREA REPORT

Use for temperature programmed or other experiment types where the gas quantity is determined from peak area by application of a calibration, from which active surface quantities can then be calculated. These quantities include:

- Metal Dispersion
- Metallic Surface Area
- Crystallite Size

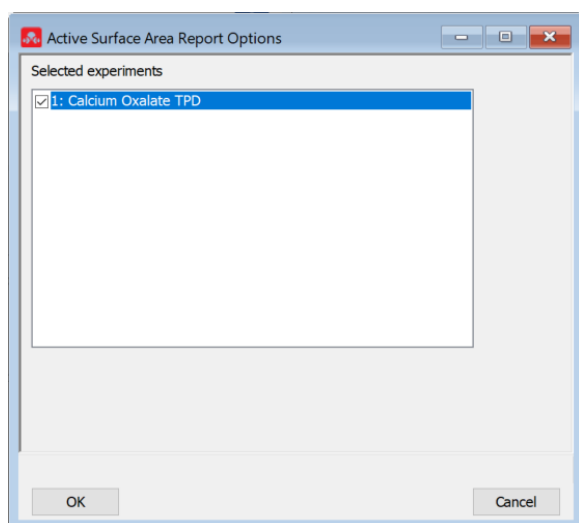

Active Surface Area Report

Selections	Description
Selected Experiments [group box]	Displays all related experiments in the current file. Only experiments with collected data are shown.



For fields and buttons not listed in this table, see [Common Fields and Buttons on page 2 - 5](#).

ADVANCED REPORTS - PYTHON MODULE

- **Summary reports.** Consist of summary sections, each containing a two-column table of label and value pairs. Summary reports are created with the *mic.summary* call.
- **Tabular reports.** Consist of one or more tables each containing one or more labeled columns of data. Tabular reports are created with the *mic.table* call.
- **Graphical reports.** Consist of a single graph with one or more curves on one or two y-axes. Graphical reports are created with the *mic.graph* call.

Calls for accessing the sample file data can be found in the *Mic Module Python Calls* section of this appendix. More advanced example python scripts are included in the analyzer software.

ADVANCED REPORTS

Up to five Advanced reports, each with up to 10 summary reports, 10 tabular reports, and 10 graphical reports can be created. To use this feature, a file containing a Python script that imports a "mic" Python module must be created. See [MicModule Python Calls on page A - 8](#) for an example of a Python script and functions for the "mic" Python module.

1. Create the Python script and save it in the *Scripts* directory.
2. Open a sample file with a *Complete* status.
3. Select *Advanced* in the view selector drop-down list at the bottom of the window to return to the tabbed view.
4. On the *Report Options* tab, select *Advanced* in the *Selected Reports* list box, then click **Edit**.
5. On the *Advanced Report Options* window, click **Add** in the *Available Scripts* group box to locate and select the Python script. Repeat for each script to be added.

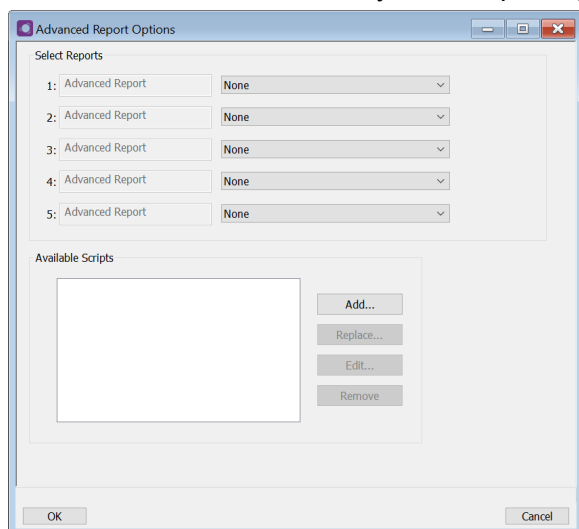

6. In the *Selected Reports* group box, click the drop-down arrows to select up to five Python scripts previously added in the *Available Scripts* box.

7. On the *Report Options* tab, click **Preview**. The Python Reports will be included on the tabs across the top portion of the *Reports* window.

Advanced Reports

Selections	Description
Advanced Report 1 through 5 [drop-down box]	Use the drop-down lists to select currently-defined functions used to define the report calculations and output.
Available Scripts [group box]	Lists the available reports and provides the option to add, replace, edit, or remove reports.
<div style="border: 1px solid green; padding: 5px;">  <p>For fields and buttons not listed in this table, see Common Fields and Buttons on page 2 - 5.</p> </div>	

BET SURFACE AREA REPORT

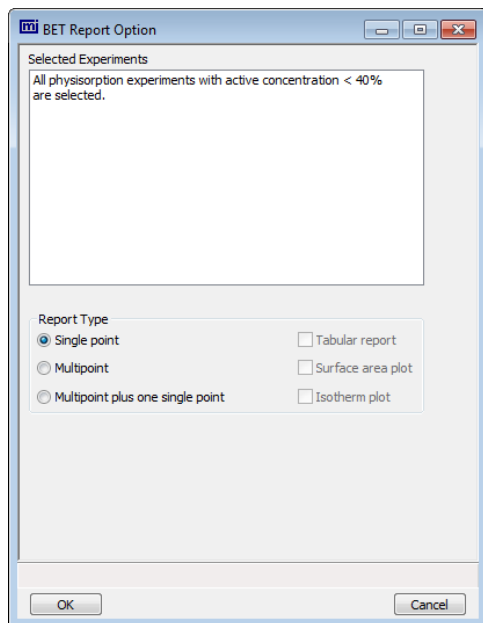

BET Report

Selections	Description
Selected Experiments [group box]	Displays all related experiments in the current file. Deselect report options to exclude from the experiment. If this is a new file, no experiments are listed. Experiments are not included in the list until BET data are collected.
Report Type [group box]	Select the report types to generate.
	For fields and buttons not listed in this table, see Common Fields and Buttons on page 2 - 5 .

FIRST ORDER KINETICS REPORT

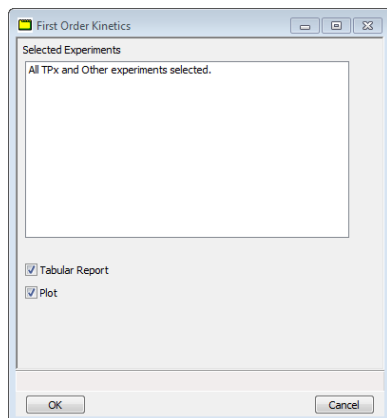

First Order Kinetics Report

Selections	Description
Plot [<i>check box</i>]	Select to have the report formatted in a graph format.
Selected Experiments [<i>group box</i>]	Displays all related experiments in the current file. Only experiments with collected data are shown.
Tabular Report [<i>check box</i>]	Select to have report formatted in table format.
	For fields and buttons not listed in this table, see Common Fields and Buttons on page 2 - 5 .

GRAPH REPORT OPTIONS

- Active Gas Flow Rate and Temperature vs Time
- Active Gas Flow Rate vs Temperature
- Active Gas Flow Rate vs Time
- Signal and Active Gas Flow Rate vs Temperature
- Signal and Active Gas Flow Rate vs Time
- Signal and Temperature vs Time
- Signal vs Temperature
- Signal vs Time [η]
- Temperature vs Time

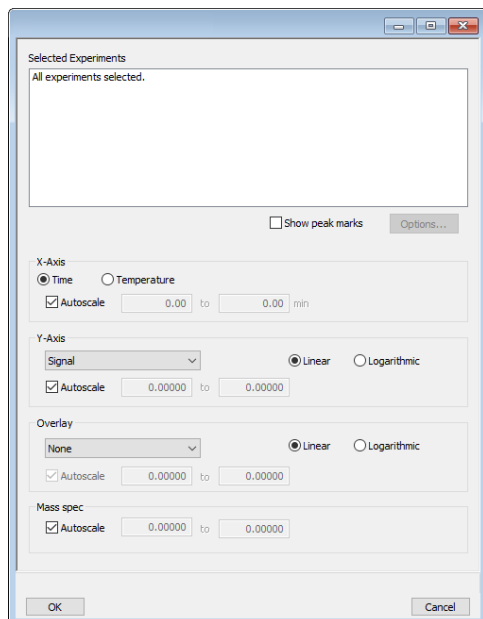

Any signal (the detector signal or the 1 or 2 auxiliary signal) may be plotted against time or temperature. Any signal can be overlaid onto the primary signal.

For color output to a monitor or printer, signals are displayed in different colors. For black and white output, different symbols are used.

Graph Report Options

Selections	Description
Options [button]	Enabled when the <i>Show peak marks</i> option is selected. Lists the peaks for the results of the highlighted experiment. Select any (or all) peaks to include in the graph.

Graph Report Options (continued)

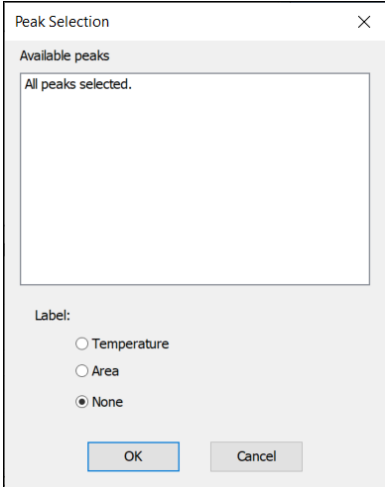
Selections	Description
	 <p>Select the peak labels to display on the graphs.</p>
Selected Experiments <i>[group box]</i>	Displays all related experiments in the current file. Only experiments with collected data are shown. This option is disabled for new files.
Show peak marks <i>[check box]</i>	<ul style="list-style-type: none"> ■ Enables the Options button to specify the peaks to include in the experiment. ■ Displays the areas and baselines on the graph. ■ Draws a straight baseline between the selected peaks.
X-axis <i>[group box]</i>	Specify <i>Time</i> or <i>Temperature</i> for the x-axis variable. Autoscale. When enabled on the report parameters windows, allows the x- and y- axes to be scaled automatically. <i>Autoscale</i> means that the x- and y- ranges will be set so that all the data is shown. If Autoscale is not selected, the entered range is used.

Graph Report Options (continued)

Selections	Description
Y-axis [<i>group box</i>]	<p>Specify <i>Time</i> or <i>Temperature</i> for the y-axis variable.</p> <p>Autoscale. When enabled on the report parameters windows, allows the x- and y- axes to be scaled automatically. <i>Autoscale</i> means that the x- and y- ranges will be set so that all the data is shown. If Autoscale is not selected, the entered range is used.</p> <p>Linear/Logarithmic. Scales the graph as <i>Linear</i> or <i>Logarithmic</i>.</p>
 For fields and buttons not listed in this table, see Common Fields and Buttons on page 2 - 5 .	

LOOP CALIBRATION REPORT

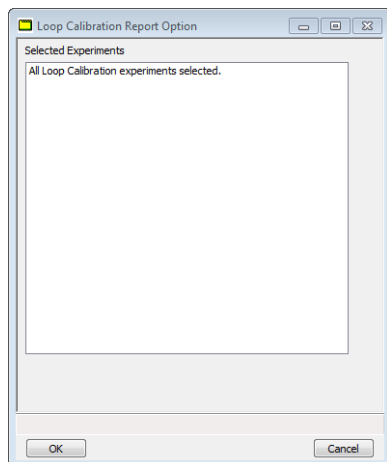

Loop Calibration Report

Selections	Description
Selected Experiments [group box]	Displays all related experiments in the current file. Only experiments with collected data are shown.
	For fields and buttons not listed in this table, see Common Fields and Buttons on page 2 - 5 .

OPTIONS REPORT

Produces a printed report of predefined collection of sample file parameters.



Options reports cannot be edited.

- Active metals
- Analysis conditions
- Report options
- Sample information

PULSE CHEMISORPTION REPORT

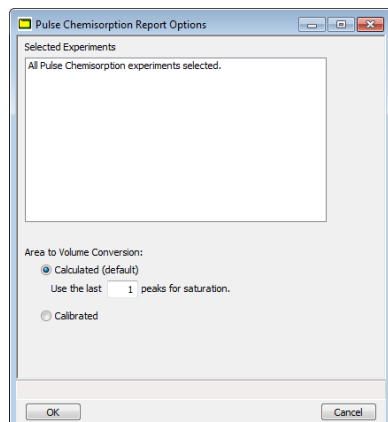

Pulse Chemisorption Report

Selections	Description
Area to Volume Conversion [group box]	Calculated. Uses the standard calculation and the raw signal. Calibrated. Uses selected peaks for the conversion. A calibration step must be included in the experiment to use this method.
Selected Experiments [group box]	Displays all related experiments in the current file. Only experiments with collected data are shown.
For fields and buttons not listed in this table, see Common Fields and Buttons on page 2 - 5.	

Quantity Adsorbed Formulas

Situation 1	Pulse adsorption experiment, no calibration applied in peak editor, report option is <i>Calculated</i> . $Q_{ads_x} = \frac{L - (L \times \frac{A_x}{A_{V_{lastN}}})}{Mass_{sample}}$
Situation 2	Pulse adsorption experiment, no calibration applied in peak editor, report option is <i>Calibrated</i> . Report displays an error message that calibration is not found and uses the formula from Situation 1.

Quantity Adsorbed Formulas (continued)

Situation 3	<p>Pulse adsorption experiment, calibration is applied in peak editor, report option is <i>Calculated</i>.</p> $Qads_x = \frac{Q_{end} - Q_x}{Mass_{sample}}$
Situation 4	<p>Pulse adsorption experiment, calibration is applied in peak editor, report option is <i>Calibrated</i>.</p> $Qads_x = \frac{L - Q_x}{Mass_{sample}}$
Situation 5	<p>Pulse reaction experiment, no calibration applied in peak editor, report option is <i>Calculated</i>.</p> $Qads_x = \frac{(L \times \frac{A_x}{Avg_{firstN}}) - (L \times \frac{A_{end}}{Avg_{firstN}})}{Mass_{sample}}$
Situation 6	<p>Pulse reaction experiment, no calibration applied in peak editor, report option is <i>Calibrated</i>.</p> <p>Report displays an error message that calibration is not found and uses the formula from Situation 5.</p>
Situation 7	<p>Pulse reaction experiment, calibration is applied in peak editor, report option is <i>Calculated</i>.</p> $Qads_x = \frac{Q_x - Q_{end}}{Mass_{sample}}$
Situation 8	<p>Pulse reaction experiment, calibration is applied in peak editor, report option is <i>Calibrated</i>.</p> $Qads_x = \frac{Q_x - 0.0}{Mass_{sample}}$

where

A_{end}	=	Area of the last peak, shown as <i>Peak Area</i> in peak editor
A_x	=	Area of peak #X, shown as <i>Peak Area</i> in peak editor
AVG_{firstN}	=	Average of first N peak areas
AVG_{lasttN}	=	Average of last N peak areas
L	=	Loop quantity calculated from the injection volume, ambient temperature, ambient pressure, and active gas concentration.

$$V_{inj} \times \frac{273.15}{T_{amb} + 273.15} \times \frac{P_{amb}}{760mm.Hg} \times \frac{C_{active}}{100.0}$$

$Mass_{sample}$	=	Sample mass (grams)
N	=	Use the last N peaks for saturation in the Pulse Chemisorption Report Options. For pulse reaction experiments (where gas is emitted by the reaction and peak areas decrease over time) this is the first N peaks.
$Qads_x$	=	Quantity Adsorbed per gram for peak #X, shown in the Pulse Chemisorption Report's peak table. The report sets negative values to 0.0. To get total quantity adsorbed, multiply by $Mass_{sample}$ and sum across peaks.
Q_{end}	=	Quantity of the last peak, shown as <i>Peak Quantity</i> in peak editor.
Q_x	=	Quantity of peak #X, shown as <i>Peak Quantity</i> in peak editor

SAMPLE LOG REPORT



Sample Log reports cannot be edited.

Inserts a log of sample operations in the reports.

This report provides information on:

- Manual control operations performed during analysis.
- Information entered using *Add Log Entry* on the sample file editor.
- Warnings and/or errors which occurred during analysis.

SUMMARY REPORT

The *Summary Report* for dynamic analyses provides a condensed summary of the peaks and selected analysis parameters.

**This page
intentionally
left blank**

8 **HARDWARE**

The analyzer has been designed to provide efficient and continuous service; however, certain maintenance procedures should be followed to obtain the best results over the longest period of time. When unexpected results occur, some common operational problems not indicated on the window and their respective causes and solutions are provided.

The following can be found on the Micromeritics web page (www.micromeritics.com).

- CryoCooler III Operator Manual (PDF)
- Error Messages document (PDF)
- Parts and Accessories

COLD TRAP

[Dewar Precautions on page 5 - 3](#)

Parts and accessories are located on the [Micromeritics](#) web page.

A *cold trap* is an available accessory used to condense liquids out of the gases flowing through the analyzer before reaching the detector. The use of a Dewar reduces the temperature of the cold trap.

1. On both ends of the tube, insert the retaining nut (knurled end first), the ferrule (small end first), and O-ring. Leave the O-rings close to the top of the tube.



2. Insert the open ends of the tube into the cold trap ports under the upper panel of the analyzer.
3. Press the tube up into the analyzer until it comes to a stop. Hold the tube in place and tighten the retaining nuts by hand. Tighten the nuts only enough to hold the tube securely in place and prevent leaks.



Do not overtighten the retaining nuts. A sufficient seal is achieved when the fittings are finger tight.



4. Fill the Dewar with the appropriate coolant.
5. Carefully slide the Dewar over the cold trap tube.



6. Rest the Dewar on the stand.
7. Place the two halves of the Dewar covers on the top of the Dewar and around the cold trap tube.



CHANGE OR CLEAN THE COLD TRAP TUBE

Occasional cleaning of the tubes is required.

1. If a Dewar is around the cold trap tube, raise the Dewar slightly and remove the Dewar shelf. Then remove the Dewar. Allow the tube to warm to room temperature.



Depending upon the state of the analyzer, the tube fittings may be hot. Use caution. Use the cotton gloves provided in the accessory kit when handling heated surfaces. These cotton gloves are not intended to protect hands when heated surfaces are above 60 °C.

2. To remove the tube, loosen the retaining nuts on the port fittings.
3. Remove the tube, retaining nuts, ferrules, and O-rings.
4. Clean the tube by flushing with isopropyl alcohol (IPA). Dry the tube in an oven or by blowing compressed air or nitrogen through it before replacing it.
5. Inspect the O-rings for cracks or other damage that might cause leaks. If the O-rings are cracked or damaged, replace them before reinstalling the tube. Otherwise, clean, dry, and re-install the O-rings.



Use only Kalrez O-rings. Kalrez is rated for both chemical and temperature suitability in this application. O-rings of other materials could burn, melt, or decompose.

6. On both ends of the tubes, insert the retaining nut (knurled end first), the ferrule (small end first), and O-ring. Leave the O-rings close to the top of the tube.



Do not over tighten the retaining nuts. Doing so may damage the O-rings. Finger tight is sufficient.

7. Hold the tube in place and tighten the retaining nuts. Tighten the nuts only enough to hold the tube securely in place and prevent leaks.

DELAY PATH

[Dewar Precautions on page 5 - 3](#)

Parts and accessories are located on the [Micromeritics](#) web page.

A *delay path* is used to reduce the perturbation (disturbance) of the gas flow caused by injections of gas through the septum.

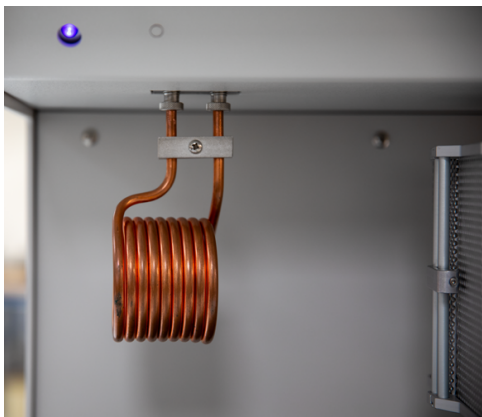

Delay path tube

1. On both ends of the tube, insert the retaining nut (knurled end first), the ferrule (small end first), and O-ring. Leave the O-rings close to the top of the tube.



- A. Retaining nut (insert knurled end first)
- B. O-ring
- C. Ferrule (insert small end first)

2. Insert the open ends of the tube into the delay path ports under the upper panel of the analyzer.

- Press the tube up into the analyzer until it comes to a stop. Hold the tube in place and tighten the retaining nuts by hand. Tighten the nuts only enough to hold the tube securely in place and prevent leaks.



Do not overtighten the retaining nuts. A sufficient seal is achieved when the fittings are finger tight.

CHANGE OR CLEAN THE DELAY PATH TUBE

Occasional cleaning of the tubes is required.

- If a Dewar is around the delay path tube, raise the Dewar slightly and remove the Dewar shelf. Then remove the Dewar. Allow the tube to warm to room temperature.



Depending upon the state of the analyzer, the tube fittings may be hot. Use caution. Use the cotton gloves provided in the accessory kit when handling heated surfaces. These cotton gloves are not intended to protect hands when heated surfaces are above 60 °C.

- To remove the tube, loosen the retaining nuts on the port fittings.
- Remove the tube, retaining nuts, ferrules, and O-rings.
- Clean the tube by flushing with isopropyl alcohol (IPA). Dry the tube in an oven or by blowing compressed air or nitrogen through it before replacing it.
- Inspect the O-rings for cracks or other damage that might cause leaks. If the O-rings are cracked or damaged, replace them before reinstalling the tube. Otherwise, clean, dry, and re-install the O-rings.



Use only Kalrez O-rings. Kalrez is rated for both chemical and temperature suitability in this application. O-rings of other materials could burn, melt, or decompose.

- On both ends of the tubes, insert the retaining nut (knurled end first), the ferrule (small end first), and O-ring. Leave the O-rings close to the top of the tube.



Do not over tighten the retaining nuts. Doing so may damage the O-rings. Finger tight is sufficient.

- Hold the tube in place and tighten the retaining nuts. Tighten the nuts only enough to hold the tube securely in place and prevent leaks.

FURNACE

When performing BET analyses, the furnace must be removed to allow placement of a cold bath Dewar around the sample.

FURNACE REMOVAL



Use the cotton gloves provided in the accessory kit when handling heated surfaces. These cotton gloves are not intended to protect hands when heated surfaces are above 60 °C.

1. Unplug the furnace cooling plug, the furnace thermocouple plug, and the furnace power plug from the analyzer.
2. Release the latch on the left side of the furnace, then open the furnace.



3. Gently lift the right side of the furnace until it is free from the support post.

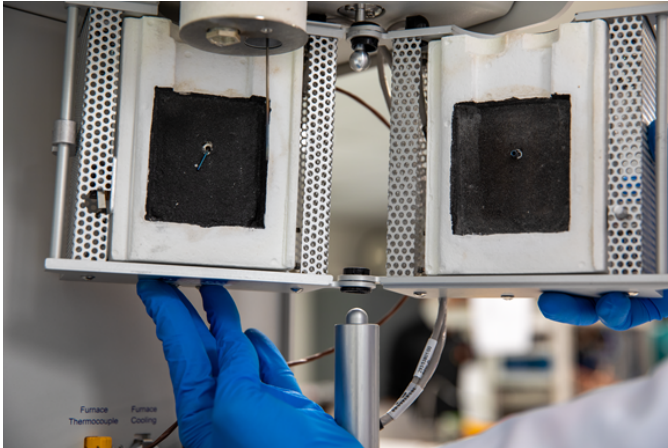

Support post and retaining knob

4. Lower the furnace, moving it away from the support post until it is free of the retaining knob.
5. Close the furnace and secure the furnace latch. Place the furnace in a location where it will be protected from damage.

FURNACE INSTALLATION

1. Hold the open furnace next to the furnace support post. Lift the furnace, moving it above the support post until the retaining knob is inserted in the hole in the top of the furnace.

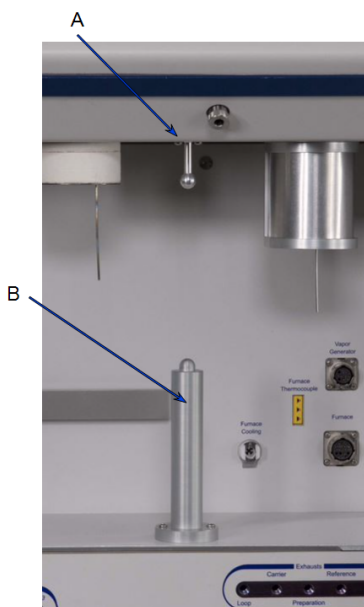

- A. Retaining knob
- B. Support post

2. When the retaining socket on the bottom of the furnace is located above the support post, gently lower the furnace until it rests securely on the post.

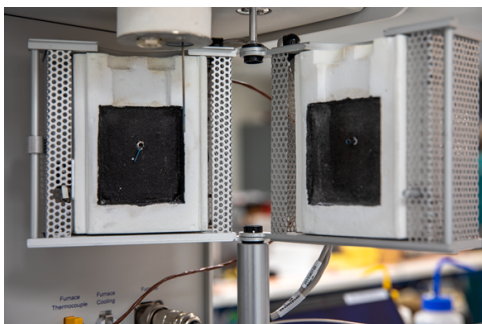

Support post and retraining knob

3. When ready to begin the experiment, close the furnace around the sample tube and secure the latch.
4. Plug the furnace cooling plug, the furnace thermocouple plug, and the furnace power plug into the appropriate connectors on the analyzer. These connectors are located on the recessed front panel.

SAMPLE THERMOCOUPLE

THERMOCOUPLE POSITION

[Use the Thermocouple Clamp on page 8-12](#)

The thermocouple must be attached to the analyzer prior to running an analysis. There are three possible configurations for the thermocouple:

- inside the sample tube
- inside the sample tube surrounded by a quartz sheath
- outside the sample tube

Best accuracy is obtained when the bare thermocouple is placed inside the sample tube. In some cases, one or more of the gases used during the experiment may react with the thermocouple's Inconel material. A quartz sheath is available to protect the thermocouple when the gases or sample used in the experiment may damage it. In this case, the sheath is placed around the thermocouple and the thermocouple is positioned inside the sample tube. When placed inside the tube, the thermocouple can be adjusted so that the end is in the sample or just above it. Always try to position the end of the thermocouple as close to the furnace thermocouple as possible.

Positioning the thermocouple along the exterior of the sample tube is less accurate than the other configurations. If the thermocouple is placed outside the sample tube, ensure it is clamped against the sample tube, and that the end does not extend below the point where the sample tube begins to taper.

1. Disconnect the analyzer from the power source.
2. Lift the top cover of the analyzer.
3. Disconnect the thermocouple connector.
4. Use an open-ended wrench to loosen the sample thermocouple fitting.



The sheath is very fragile and can be easily broken. Because the sheath is made of quartz, cotton gloves must be worn when handling the sheath. Oils from fingers may lower the quartz melting point.

5. Adjust the thermocouple:

To change the position:	<ol style="list-style-type: none">a. Loosen the fitting for the plug in the alternate thermocouple opening and remove the plug.b. Remove the fitting that retains the sample thermocouple.c. Move the sample thermocouple from its current position to the new position.d. Place the plug in the unused thermocouple opening and tighten the fitting. Reinstall the sample thermocouple retaining screw. <p>If using the quartz sheath, perform the following before proceeding. The sheath can only be used when the thermocouple is being placed inside the sample tube.</p> <ol style="list-style-type: none">i. Remove the ferrule from the thermocouple, straighten the thermocouple as much as possible.ii. Insert the thermocouple into the sheath.iii. Place a larger ferrule around the sheath.
To adjust the length:	See Determine the length of the thermocouple on the facing page . Adjust the thermocouple wire up or down as needed.

6. Tighten the thermocouple fitting.
7. Return the upper front panel and the top panel to their original closed positions.
8. Power ON the analyzer.

DETERMINE THE LENGTH OF THE THERMOCOUPLE

When adjusting the length of the exposed portion, consider the following:

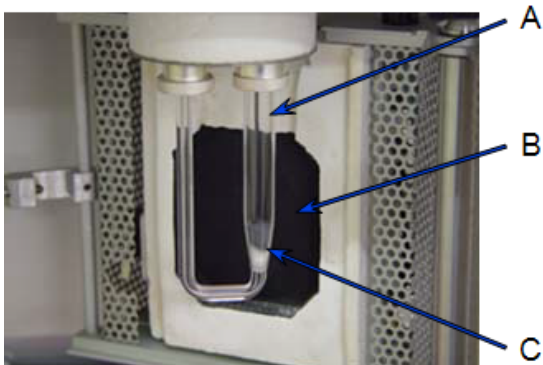

- A. Thermocouple
- B. Recessed area inside furnace
- C. End of thermocouple should be 2 to 3 mm (1/8 in.) above the sample

- The end of the thermocouple should be aligned as closely as possible with the furnace thermocouple.
- The end of the thermocouple should never be placed outside the painted (black), recessed area inside the furnace.
- If the thermocouple is positioned inside the tube, its end should generally be located approximately 2 to 3 mm (1/8 in.) above the sample surface. In some cases, allow the thermocouple to extend into the sample.
- If the thermocouple is positioned outside the tube, its end should not extend below the point where the sample tube begins to taper.

USE THE THERMOCOUPLE CLAMP

If the thermocouple is placed outside the sample tube, a clamp must be used to secure the thermocouple to the sample tube.

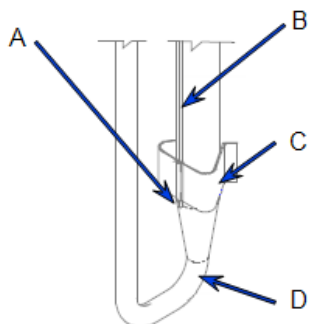

- A. Do not allow the thermocouple to extend below the point where the sample begins to taper
- B. Thermocouple
- C. Clamp
- D. Sample tube

RECALIBRATE THE SAMPLE THERMOCOUPLE

[Calibration on page 13 - 1](#)

A calibration file is created specifically for each analyzer before the analyzer is shipped. This calibration file is installed during installation. If the original calibration file is corrupted or missing, or if the sample thermocouple is replaced, recalibration will be needed.



Do not attempt to calibrate anything other than the sample thermocouple without prior approval from a qualified Micromeritics Service Representative.

Prior to recalibration, ensure:

- The analyzer is powered ON and the application is running.
- All heat zones to be calibrated are stabilized at ambient temperature.
- Familiarity with manually controlling the analyzer.
- All gas flows through the analyzer are stopped.
- The furnace is open, and the sample tube is removed (the thermocouple is bare and exposed).
- A traceable thermocouple meter and a water bath (ambient temperature) to immerse the sample thermocouple are available.

1. Go to **Unit [n] > Calibration > Calibrate**.



2. Place the water bath around the thermocouple so that the lowest 25 mm (1 in.) is immersed in the water. Place the thermocouple meter (reference thermocouple) parallel to the sample thermocouple so that both thermocouples are at the same temperature.

3. After the reference thermocouple meter reading stabilizes, enter the ambient temperature reading in the *Low Cal.* field on the *Instrument Calibration* window.
4. Remove the water bath. Move the tip of the reference thermocouple so that it touches the sample thermocouple tip yet allows the furnace to be closed.
5. Go to **Unit [n] > Enable Manual Control**. Ensure a checkmark displays to the left of the menu item. If the analyzer schematic does not display, go to **Unit [n] > Show Instrument Schematic**. Set the furnace target temperature to 1000 °C. Use a ramp rate of 50 °C/min. Observe the schematic to ensure that both the furnace temperature and sample temperature are increasing.
6. After the furnace and sample temperature have stabilized, enter the reading from the reference thermocouple in the *High Cal.* field on the *Instrument Calibration* window.
7. Use manual control of the furnace to return the temperature to ambient.
8. On the *Instrument Calibration* window, click **Accept** to save the new values. Make a backup copy of the settings when prompted.

SAMPLE TUBE

SAMPLE TUBE INSTALLATION



Use the cotton gloves provided in the accessory kit when handling heated surfaces. These cotton gloves are not intended to protect hands when heated surfaces are above 60 °C.



Wear latex gloves when handling the quartz sample tube. The natural oils in human skin can chemically damage and weaken the quartz tube. It is also important that the sample tube and its components, as well as the sample and exhaust ports, be clean and free of debris. Dust particles from quartz wool or the insulator disc of previous analyses may adhere to the port and/or components, preventing a proper seal of the sample tube.



Use only Kalrez (or equivalent) O-rings. Kalrez is rated for both chemical and temperature suitability in this application. O-rings of other materials could burn, melt, or decompose.

1. Open the furnace.
2. Remove any sample tube stoppers immediately before connecting the sample tube to the analyzer.
3. Carefully slide the sample tube collar over the open ends of the sample tube. The ferrules should be placed (narrow end down) on the smaller side of the sample tube.



For quartz tubes, do not allow the collar to slide down rapidly to the curved portion of the tube. This could damage the tube.

4. Place an O-ring around each opening of the sample tube.
5. Insert the open ends of the sample tube into the openings under the upper panel, aligning the thermocouple in the proper position.
6. Push the sample tube up into the sample port until it comes to a stop.
7. Close and latch the furnace. The furnace will not heat unless closed.

SAMPLE TUBE REMOVAL



The furnace and sample tube may remain very hot for some time after analysis has ended. The sample tube retaining nuts are extremely hot, approximately 110 °C. Use extreme caution!

It is recommended to allow the furnace and sample tube to return to ambient temperature before touching them. If the sample tube has cooled, use rubber gloves when removing it. If it is still hot, use the cotton gloves provided.

1. Unlatch and open the furnace.



Support the sample tube retaining nuts so that they do not fall rapidly out of the analyzer. This may damage the sample tube.

2. Loosen the sample tube retaining nuts, be very careful and support them. As the nuts are loosened, support the sample tube and pull it gently down out of the analyzer. When the nuts are sufficiently loose, the sample tube, retaining nuts, ferrules, and O-rings should slide out of the analyzer. If necessary, use the extractor tool to pull the O-rings out of the ports.
3. Inspect the O-rings for cracks or other damage that might cause leaks. If the O-rings are cracked or damaged, replace them before reinstalling the sample tube. Additional O-rings are shipped with the analyzer. Otherwise, clean, dry, and re-install the O-rings.

SAMPLE TUBE FILTER OR O-RING REPLACEMENT

A frit filter is used to protect the analyzer internal components from contaminants that may be forced out of the sample tube during an analysis. As the analyzer is used, the filter may gradually become clogged with trapped particles. If the filter does become blocked, it must be removed and cleaned or replaced. One indication of a clogged filter is a sample pressure greatly exceeding atmospheric pressure. The nominal sample pressure reading should be a few mmHg above atmospheric pressure

1. Loosen the analysis port fittings while holding the sample tube.
2. Carefully remove the sample tube by unscrewing the retaining nuts. Do not allow the nuts to slide down into the curved portion of the sample tube or the tube may break.
3. Remove the left (smaller) sample tube fitting (it has a tube within a tube).
4. Use a small diameter probe to remove the O-ring and frit filter disk from the sample tube fitting.
5. Install a new (or cleaned) analysis port filter in the sample tube fitting.
6. Inspect the O-ring for cracks or cuts. If the O-ring is damaged, replace it with a new O-ring. Otherwise, clean the O-ring, dry it, and place it in the sample tube fitting. Ensure the O-ring is securely in place.
7. Place the left sample tube fitting back into position and tighten it slightly.
8. Reinstall the right sample tube fitting and sample tube, then tighten both fittings.

SEPTUM

The septum is used to inject quantities of gas into the analyzer.

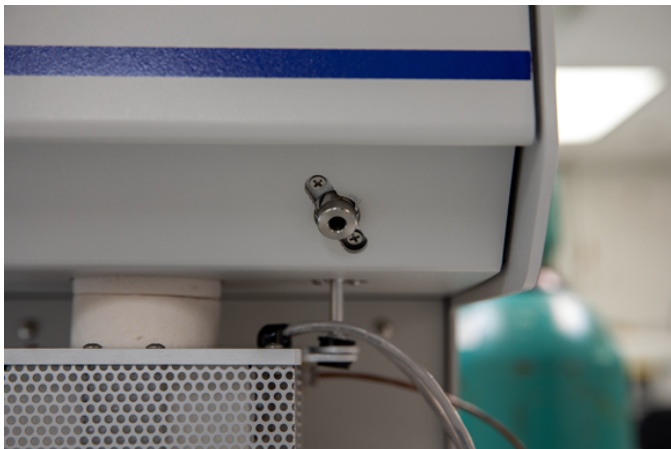

Septum port



Do not use the septum at pressures above ambient. Gas may escape at elevated pressures.

Accuracy of data is diminished when poor techniques are used for injecting gas through the septum.

Injecting the gas through the septum causes a peak to appear, but it also causes a perturbation in the flow of gas through the analyzer. This perturbation is visible in the peak data. To minimize this perturbation, inject the gas more slowly into the septum. Prolonging the injection causes the peak to spread.

An injection method should be developed to balance the need to minimize the perturbation with the need for sharper peaks. See [Peak Editor on page 6 - 2](#) to adjust peak data to reduce the effects of perturbation.

- Always hold the syringe by its metal parts away from the needle. Holding the syringe by the glass allows body heat to affect the volume of gas in the syringe.
- After filling the syringe, allow the syringe to lie on a room temperature surface for about a minute. This ensures that the syringe and its contents are at room temperature.
- If the gas used is lighter than air, do not allow the filled syringe to remain in a vertical position (needle up) — the gas will diffuse out and the total volume will be reduced.

Fill the syringe

1. Empty the syringe completely.
2. Insert the syringe into a septum accessory installed on the loop exhaust port or gas regulator.
3. Draw the syringe plunger back until the syringe is completely filled with gas.
4. Remove the syringe from the septum and allow it to return to room temperature as described previously.
5. Press the plunger into the syringe until the correct amount of gas is contained in the syringe.

Alternate method to fill the syringe with nitrogen (evaporating from liquid nitrogen)

1. Empty the syringe.
2. Hold the tip of the needle just above the surface the liquid nitrogen.
3. Draw the syringe plunger back until the syringe is filled with nitrogen gas.
4. Allow the syringe to stabilize at room temperature.
5. Push the plunger into the syringe until the correct amount of gas is contained in the syringe.

Inject gas into the analyzer

1. Insert the needle fully into the septum.
2. Press the plunger into the syringe completely to ensure that the entire quantity of gas is injected from the syringe.
3. Remove the syringe.

SEPTUM REPLACEMENT



The septum usually requires replacing after approximately 100 injections when using the 1 mL syringe.



1. Turn the knurled nut counter-clockwise and remove it from the injection port.
2. Tap the nut into the palm of your hand to remove the septum and discard the used septum.
3. If the washer came out when the septum was removed, place the washer back into the knurled nut first.
4. Place a new septum into the knurled nut.
5. Place the knurled nut back onto the injection port. Turn the nut clockwise to finger tighten.



Do not use a wrench to tighten the septum retaining nut. Do not overtighten the retaining nut. Doing so may damage the septum or the fitting.

**This page
intentionally
left blank**

9 MAINTENANCE

The analyzer has been designed to provide efficient and continuous service; however, certain maintenance procedures should be followed to obtain the best results over the longest period of time. When unexpected results occur, some common operational problems not indicated on the window and their respective causes and solutions are provided.

The following can be found on the Micromeritics web page (www.micromeritics.com).

- CryoCooler III Operator Manual (PDF)
- Error Messages document (PDF)
- Parts and Accessories

If the equipment needs to be relocated, check with your Micromeritics Service Representative. The equipment must be positioned such that the mains supply is not obstructed and is easily accessible to disconnect the equipment from the AC main power supply.



Improper handling, disposal, or transportation of potentially hazardous materials can result in serious injury or damage to the instrument. Always consult the SDS when working with hazardous substances. Safe operation and handling of the instrument, supplies, and accessories are the responsibility of the operator.



Do not service or modify this instrument without authorization from Micromeritics Service Personnel. It does not include any user-serviceable parts.



When lifting or relocating the instrument, use appropriate lifting and transporting devices designed for heavy equipment. Ensure that enough personnel are available to assist with the movement of the instrument.
The ChemiSorb Auto weighs approximately 59 - 63.5 kg (130-140 lb).



Use of a power cord or power supply not provided with the instrument could cause personal injury or damage to the equipment. If a replacement is needed, contact your Micromeritics Service Representative. Detachable power supply cords with an inadequate rating could cause significant instrument damage or physical harm.

Do not add anything between the power cord and the power source that would compromise the earth ground.

Do not remove or disable the grounding prong on the instrument power cord.

The analyzer and peripheral devices **must** be installed on their own dedicated power line. Other devices — such as motors, generators, or ovens — **should not** be placed



on the same power line.

Replacement power supply cords must be rated for the stated specifications.

If the instrument does not have a power switch and must be disconnected from the wall outlet when powering off, position the instrument where the wall outlet is easily accessible.



Prior to moving the instrument, disconnect and remove all glassware from the instrument. Ensure all gas shut-off valves on the gas cylinder have been closed and gas lines disconnected from the instrument. Contact your Micromeritics Service Representative.

SAFE SERVICING



Do not service or modify this instrument without the authorization of Micromeritics Service Personnel.

To ensure safe servicing and continued safety of the instrument after servicing, service personnel should be aware of the following risks:

Product specific risks that may affect service personnel:

- **Electrical.** Servicing or repair could require opening the outer panels and exposing energized electrical components.
- **Liquid nitrogen.** See [Dewar Precautions on page 5 - 3](#).

Protective measures for these risks:

- **Electrical.** The electrical components operate at low voltage (24 V or less) and pose low risk when energized. However, maintenance, troubleshooting, and repairs should be performed with the instrument de-energized whenever possible, in accordance with standard electrical safety guidelines.

Verification of the safe state of the instrument after repair:

- Disable the TCD and insert a blank tube into the port.
- Set all heat zones back to the default temperature.

GUIDELINES FOR CONNECTING GASES

Regulator Pressure Settings

Analyzer	Gauge should indicate
ChemiSorb Auto	14 - 16 psig (95 - 110 kPag)



Exceeding the maximum recommended pressure could cause personal injury or damage the instrument.



These instructions refer to the installation of a gas line, regulator, and gas cylinder for each type of gas used. If expansion kits or other accessories are used in the lab, special consideration should be given to these configurations when installing the gas lines.



Improper handling, disposal, or transportation of potentially hazardous materials can result in serious injury or damage to the instrument. Always consult the SDS when working with hazardous substances. Safe operation and handling of the instrument, supplies, and accessories are the responsibility of the operator.

- Ensure the gas cylinder is closed before connecting to the analyzer.
- Place gas cylinders within 6 feet (2 m) of the gas inlets of the analyzer. Place the cylinders close enough to allow for proper connection at the analyzer inlet.

Using gas line extenders on gas cylinders located in remote areas may degrade gas quality and reduce pressure. Long gas lines, such as those used with gas cylinders placed in remote areas, should be purged if they are contaminated with water or particulates.

When possible, avoid placing gas cylinders in remote locations. It is always best to have gas cylinders located near the analyzer.

- Use a retaining strap (or other appropriate tether) to secure the gas cylinder.
- Always use the gas lines provided with the analyzer. It is very important that proper gas lines are used with the analyzer. The necessary lines are provided. They are all 6 feet (2 m). One is used for the high pressure input, and the other two are used for the low pressure input.
- Carefully route the gas lines from the cylinder to the analyzer avoiding overlapping or entangling gas lines. This will help avoid confusion when maintenance is required.
- Label the gas line at the analyzer inlet for proper identification and maintenance.
- Replace gas cylinders before gas is depleted. It is best to replace a gas cylinder when the pressure reads approximately 600 psig (4140 kPag) on the high-pressure gauge. Contaminants adsorbed to the walls of the cylinder will desorb as the pressure decreases.

- Input air must be clean, dry, filtered, and delivered at a maximum pressure of 40 psig. If using an air compressor, a secondary air filter is required (MIC part #710-25601-00). The air filter should be regularly checked for fluid buildup (and drained as required), and the filter element replaced as necessary. Particulates, water vapor and oil vapor can contaminate the instrument.

CONNECT GAS TO ANALYZER

Regulator Pressure Settings

Analyzer	Gauge should indicate
ChemiSorb Auto	14 - 16 psig (95 - 110 kPag)



Exceeding the maximum recommended pressure could cause personal injury or damage the instrument.



Ensure the gas cylinder is closed before connecting the gas line to the analyzer.

The 8 gas inlet ports are located underneath the front cover.



- A. Carrier gas inlets (4)
- B. Loop gas inlets (4)
- C. Exhaust ports
- D. *Air In* port

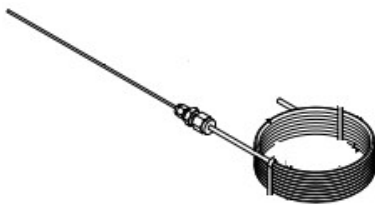

Port

Gas Type	Port Label
Carrier	1 through 4
Loop	11 through 14
Exhaust	One port each for Loop and Carrier

1. Attach the gas line to the appropriate port.
2. Set the regulator pressure as described in the Regulator Pressure Settings table.
3. Repeat steps 1 and 2 to connect all required gases.
4. Ensure any unused gas inlet ports are plugged.
5. Record the gas installed in the port in the analysis program (**Unit [n] > Gas Connections**) after the software is installed. See [Gas Connections on page 2 - 13](#).

REPLACE A GAS CYLINDER

Regulator Pressure Settings

Analyzer	Gauge should indicate
ChemiSorb Auto	14 - 16 psig (95 - 110 kPag)



Exceeding the maximum recommended pressure could cause personal injury or damage the instrument.



These instructions apply to working with inert gases only. When working with hazardous gases, follow the safety procedures established by your lab.

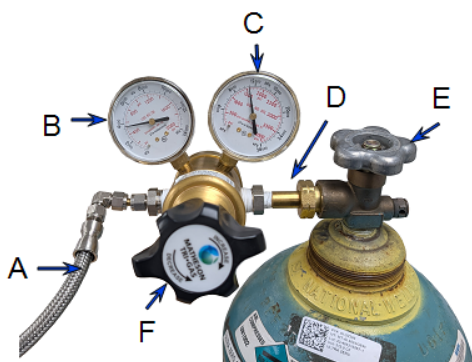

- A. Gas tubing to instrument
- B. Low pressure gauge
- C. High pressure gauge
- D. Regulator connector nut
- E. Gas cylinder shut-off valve
- F. Regulator control knob

Disconnect a Depleted Gas Cylinder

1. Close the regulator shut-off valve and gas cylinder shut-off valve by turning the knobs clockwise.
2. Disconnect the gas line from the regulator. Gas will be vented from the line. It is not necessary to disconnect the gas line from the analyzer inlet if the cylinder will be replaced immediately with one of the same type.
3. Open the gas regulator shut-off valve by turning the knob counter-clockwise. Gas will be vented from the regulator.
4. Turn the regulator control knob clockwise to open and vent any remaining gas. Both gauges should read at or near zero. If not, make sure the gas regulator shut-off valve is open.

5. Close the regulator by turning the control knob counter-clockwise.
6. Use an appropriate wrench to loosen the nut at the regulator connector nut then remove the regulator from the cylinder.
7. Replace the protective cap on the depleted cylinder. Disconnect the retaining strap and move the cylinder to an appropriate location.

Connect a Gas Cylinder

1. Use an appropriate cylinder wrench to remove the protective cap from the replacement gas cylinder.
2. Place the protective cap in a secure location. It will be needed to recap the gas cylinder when it is depleted and replaced.
3. Attach the gas regulator to the gas cylinder connector. Hand tighten the nut, then use an appropriate wrench to tighten an additional 3/4 turn.



Over-tightening the fitting may cause a leak.

4. Check for leaks at the high pressure side of the regulator and in the connector.
 - a. Turn the regulator control knob fully counter-clockwise.
 - b. Slowly open the gas cylinder shut-off valve, then quickly close it.
 - c. Observe the pressure on the high pressure gauge for approximately one minute.
 - If the pressure is stable, proceed with the next step.
 - If the pressure decreases, tighten the regulator connector nut until it becomes stable. If the pressure does not remain stable, remove the regulator and clean all contacts at the regulator connection, then reinstall the regulator.
5. Purge the air from the lines by doing the following:



Purge the regulator before starting to prevent contamination of the analysis gas supply.

- a. Open the gas cylinder valve to pressurize the regulator, then close the valve.
- b. Adjust the *Pressure Control* knob to approximately 5 psig (35 kPag).
- c. Turn the regulator *Shut-off* valve counter-clockwise to open. Allow gas to flow until both gauges read approximately zero.
- d. Close the regulator *Shut-off* valve to stop gas flow.
- e. Reconnect the gas line to the regulator.
- f. Use two 7/16 in. (11 mm) wrenches to tighten the gas line connection. Hold one wrench fitting steady and use the other to tighten the connector nut.

6. Set the analyzer pressure by doing the following:
 - a. Turn the *Regulator Control* knob clockwise until the low pressure gauge indicates the appropriate pressure.
 - b. Open the regulator *Shut-off* valve.
 - c. Open the gas cylinder *Shut-off* valve and flow gas for 10 to 30 seconds.
 - d. Close the gas cylinder *Shut-off* valve.
 - e. Close the gas cylinder valve.
7. If the gas line to the instrument inlet was previously disconnected, reconnect it now.

PERFORM A LEAK TEST

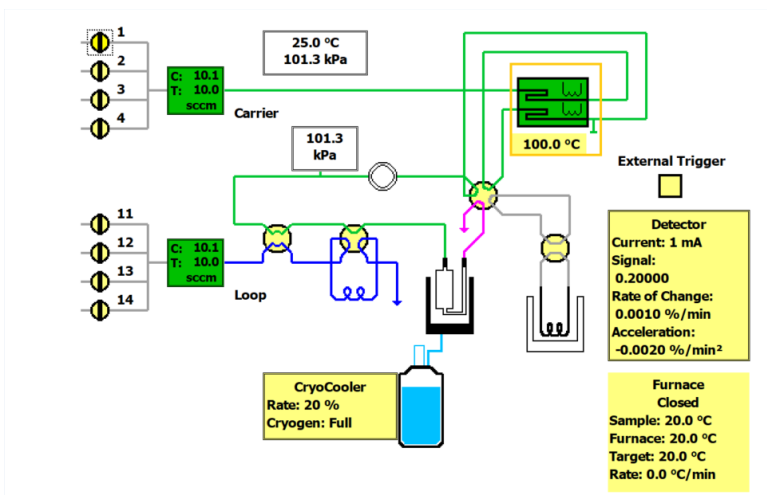

1. Go to **Unit [n] > Enable Manual Control**. Ensure a checkmark displays to the left of the menu item. If the analyzer schematic does not display, go to **Unit [n] > Show Instrument Schematic**.
2. Prepare for the leak test:
 - a. Set all heat zones to ambient temperature.
 - b. Set two MFCs to 50 sccm.
 - c. Allow the analyzer to cool to room temperature.
 - d. Connect helium to an inlet of each gas path to be tested.



This test must be performed in the order provided to ensure the analyzer is fully tested.

CARRIER GAS PATH LEAK TEST

1. Right-click the analysis valve and select *Preparation*.
2. Right-click the blend valve and select *Bypass*.
3. Right-click the loop valve and select *Fill*.
4. Install an empty sample tube on the sample port.
5. Plug the carrier gas exhaust outlet.
6. Set the helium regulator to less than 5 psi (34.5 kPag).
7. Right-click the helium carrier valve and select *Open*.
8. Set Carrier MFC to 20 sccm.
9. Observe the carrier gas MFC reading as it slowly drops to zero. A flow reading of zero indicates the flow path between the carrier gas flow MFC and carrier gas exhaust does not leak.
10. Right-click the loop valve and select *Inject*.
11. Observe the carrier gas MFC reading as it slowly drops to zero or remains at zero from the previous test. A flow reading of zero indicates the flow path between the carrier gas MFC and the carrier gas exhaust outlet does not leak. This tests all fitting connections in the gas flow path, the remaining parts of the loop valve, and the loop.
12. Install an empty sample tube on the sample port.
13. Right-click the analysis valve and select *Analysis*
14. Observe the carrier gas MFC reading as it slowly drops to zero or remains at zero from the previous test. A flow reading of zero indicates the flow path between the carrier gas MFC and the carrier gas exhaust outlet does not leak. This tests all fitting connections in the gas flow path, the sample tube, and the remaining parts of the analysis valve.
15. Install a cold trap or delay line on the trap port.
16. Right-click the trap valve and select *Trap*.
17. Observe the carrier gas MFC reading as it slowly drops to zero or remains at zero from the previous test. A flow reading of zero indicates the flow path between the carrier gas MFC and the carrier gas exhaust outlet does not leak. This tests all fitting connections in the gas flow path, the remaining parts of the trap valve, and the trap.
18. Right-click the helium carrier gas MFC and select *Close*.
19. Close the helium carrier valve.
20. Remove the plug from the carrier exhaust outlet.
21. Reset the helium regulator to its original pressure.

LOOP GAS PATH LEAK TEST

1. Right-click the loop valve and select *Fill*.
2. Right-click the blend valve and select *Bypass*.
3. Plug the loop gas exhaust outlet.
4. Right-click the helium loop valve and select *Open*.
5. Set Loop MFC to 20 sccm.
6. Observe the loop gas MFC reading as it slowly drops to zero or remains at zero from the previous test. A flow reading of zero indicates the flow path between the loop gas MFC and the loop gas exhaust outlet does not leak. ¹This tests all fitting connections in the loop gas flow path and the tubing to the loop valve.
7. Right-click the loop gas MFC and select *Close*.
8. Close the helium loop valve.
9. Remove the loop exhaust plugs.

PREVENTIVE MAINTENANCE

Perform the following preventive maintenance procedures to keep the analyzer operating at peak performance. Micromeritics also recommends that preventive maintenance procedures and calibration be performed by a Micromeritics Service Representative every 12 months.

Procedure	3 months or 75 runs	6 months or 150 runs	9 months or 225 runs	12 months or 300 runs
Change septum		U-R		F
Change Injection loop		U-I-A		F
Sample tube filter		U-R		F-R
Clean analyzer exterior		U-I-A		F
Adjust sample thermocouple		U-I-A		F
Clean the cold trap	U-I-A	U-I-A	U-I-A	F
Replace TCD		U-I-A		F
Clean Dewar	U-I-A	U-I-A	U-I-A	F
Change sample O-rings				F-R
Perform leak check		U-I-A		F
Check temperature stability				F
Check sample thermocouple calibration				F-A
Perform calibration run				F

Legend:

- U** User performed
- F** Factory / Micromeritics Service procedure
- I** Inspect
- R** Replace
- A** As necessary

CHECK AND CLEAN THE DEWAR



When handling Dewars, follow the precautions outlined in [Dewar Precautions on page 5 - 3](#).



Always handle glass Dewars with care. Any product incorporating a vacuum is a potential safety hazard and should be treated with caution. If in doubt, contact your safety officer.

Ice and suspended frost particles may accumulate in the bottom of the analysis port Dewar. Particles or deposits exceeding 1/4 in. (6 mm) in depth may jam between the bottom of the sample tube and the bottom of the Dewar.

Accumulations of fine particles impede liquid nitrogen circulation around the bottom of the sample tube. This causes the sample temperature to be slightly higher which, in turn, can cause pore volume measurement errors in those samples exhibiting high isotherm slope above 0.97 relative pressure.

Accumulated ice is likely to melt and form a pool of water in the Dewar if all liquid nitrogen evaporates. The water must be removed, otherwise it will solidify when liquid nitrogen is added and could press on the bottom of the sample tube causing breakage.

To ensure problems do not develop due to ice accumulation, check the Dewar after each use. Clean on a weekly basis.

1. Remove the Dewar from the analyzer.
2. Pour out liquid nitrogen into an appropriate cryogenic container. Do not re-use liquid nitrogen.



Do not pour liquid nitrogen directly into a sink. Doing so may cause drain pipes to burst.

3. Rinse the Dewar with warm water to melt any remaining ice accumulation which may remain. Dry thoroughly.
4. Replace the Dewar.

CLEAN THE INSTRUMENT

The exterior casing of the instrument may be cleaned using a clean, lint-free cloth dampened with isopropyl alcohol (IPA), a mild detergent, or a 3% hydrogen peroxide solution. Do not use any type of abrasive cleaner. It is not necessary to remove knobs, screws, etc. while cleaning.



Do not allow liquid to penetrate the casing of the instrument. Doing so could result in damage to the unit.

Use only a mild detergent in water to clean safety shields. The use of isopropyl alcohol can damage the shield surface.

POWER INSTRUMENT ON AND OFF



Do not connect or disconnect cables when the instrument is powered ON.

The ChemiSorb Auto does not have a power switch. To power the instrument on or off, the instrument must be connected to or disconnected from the power source. The blue LED light on the front panel indicates power has been applied to the instrument.

When the system is powered on for the first time or after a period of non-use, allow it to warm up for at least three hours before analyses. During this time, a purge carrier gas (such as helium or nitrogen) should be flowed through the system at about 50 cm³/min.

PURGE THE SYSTEM

When changing the gas that is flowing through the analyzer, or when the type of gas connected to a port is changed, purge the analyzer of the previous gas by flowing the new gas. The system should also be purged if the loop is changed.

If changing gases during an analysis, allow the new gas to flow for a period of time before creating conditions that cause the experiment to begin (such as elevating the temperature). In some cases, purge one gas by flowing an inert gas for a period of time before starting to flow another gas. This may be useful for avoiding undesirable combinations of gases within the analyzer.

To flow an inert gas between incompatible gases, insert a *Change Gas Flows* step (in which an inert gas is flowed for a period of time) and a *Wait* step (to wait for the inert gas to purge the analyzer) between other steps that involve incompatible gases.



When gas flows are changed while the analyzer is recording data, the gas flow is briefly disturbed. This may result in a brief period of noise or other visible disturbances on the peak data. Either disregard the disturbance or insert a *Wait for stable baseline* step immediately after changing gas flows.



Purge one line at a time. It is the operator's responsibility to ensure that dangerous combinations of gases are not created while using Manual Control. It may be necessary to flow an inert gas through the system between flows of incompatible gases.

1. Go to **Unit [n] > Enable Manual Control**. Ensure a checkmark displays to the left of the menu item. If the analyzer schematic does not display, go to **Unit [n] > Show Instrument Schematic**.
2. Purge all air from the gas lines. These steps should be performed for each inlet valve for the carrier, and loop gas lines where a gas cylinder is connected.
 - a. Select *Set Flow Rate* and enter 50.
 - b. Click **OK**.
 - c. Allow the gas to flow for approximately 20 minutes or until the lines have been purged of air.
 - d. Repeat Step 4 for each valve that has a gas cylinder connected.

Change the Gas Flow During an Analysis

When changing gases during an analysis, allow the new gas to flow for a period of time before creating conditions that cause the experiment to begin (such as elevating the temperature). Purge one gas (by flowing an inert gas for a period of time) before starting to flow another gas. This may be useful for avoiding undesirable combinations of gases within the analyzer.

To flow an inert gas between incompatible gases, insert a *Change Gas Flows* step (in which an inert gas is flowed for a period of time) and a *Wait step* (to wait for the inert gas to purge the analyzer) between other steps that involve incompatible gases.



When gas flows are changed while the analyzer is recording data, the gas flow is briefly disturbed. This may result in a brief period of noise or other visible disturbances on the peak data. Either disregard the disturbance or insert a *Wait for stable baseline* step immediately after changing gas flows.

CHANGE THE INJECTION LOOP



The equipment images in this topic may differ slightly from your equipment; however, the instructions are the same unless otherwise noted.

1. Ensure that no heat is being applied to the analyzer. If necessary, enable manual control and set the target temperature for the heat zones to ambient. Wait for the analyzer to cool.
2. Remove the two screws on the top of the instrument and lift the top panel.



Depending upon the state of the analyzer, the internal components may be hot. Use caution.

3. Loosen the loop with a 1/4 inch wrench.
4. Pull up and remove the injection loop.

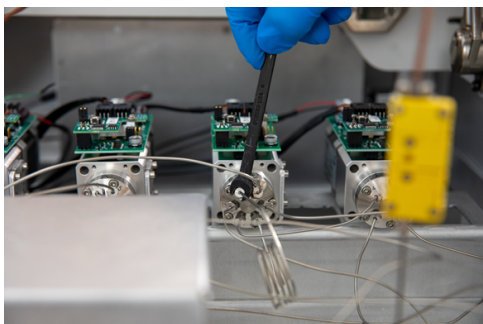

5. Install the replacement injection loop by placing the ends of the loop into the sides of the valve and turning the nuts finger tight. The injection loop size provided with the instrument is 0.5mL. Additional loop sizes of 1mL and 5mL are available as an accessory.
6. Tighten the loop nuts securely, using a 1/4 in. open-end wrench.
7. Check the injection loop for leaks. If a leak is detected, the injection loop is probably not installed properly. Repeat the installation and check for leaks again. See [Perform a Leak Test on page 9-10](#).
8. Close the top and lower front panels.
9. After installing a new injection loop, the loop must be calibrated. Go to **Unit [n] > Unit Configuration** to update the loop volume.



The smaller loops connect to the same openings in the valve, but rest in a different position than the larger loop.

10 TROUBLESHOOTING

The analyzer has been designed to provide efficient and continuous service; however, certain maintenance procedures should be followed to obtain the best results over the longest period of time. When unexpected results occur, some common operational problems not indicated on the window and their respective causes and solutions are provided.

The following can be found on the Micromeritics web page (www.micromeritics.com).

- CryoCooler III Operator Manual (PDF)
- Error Messages document (PDF)
- Parts and Accessories

Most operational problems are caused by:

- Leaks (commonly found at the sample tube O-ring at the analysis port)
- Sample weighing errors
- Use of too much analysis bath fluid in the Dewar at the start of an analysis
- Entry of incorrect system volume for analysis
- Impure gas supply

When unexpected analysis results occur, check the above first. Some common operational problems not indicated on the window and their respective causes and solutions are provided below:

Does not work when powered ON

Cause A: Power cord is not fully inserted at one of the ends

Action A: Insert power plug firmly into outlet socket. Insert unit connector into power connector opening.

Cause B: No power at outlet.

Action B: Plug in another electrical device to test outlet. If there is no power, contact electrician.

Cause C: Plug prongs are bent so that contact is not made at outlet.

Action C: Gently move power plug at the outlet while watching the status LEDs on the analyzer front panel. If at least one LED becomes illuminated, have an electrician replace the outlet or the plug.

Cause D: Power cord is damaged.

Action D: Have an electrician check cord using a test meter. Replace cord if defective.

Cause E: Loose internal connection or broken wire.

Action E: Call a Micromeritics Service Representative for repair or replacement.

Liquid nitrogen boils away too quickly to complete an analysis.

Cause A: Dewar damaged.

Action A: Replace Dewar.

Cause B: Lengthy analysis.

Action B: Refill Dewar during analysis.

Specified temperature not reached or not maintained.

Cause: Thermocouple or another internal component is damaged or disconnected.

Action: Contact the appropriate service personnel.

Gas drained from gas cylinder.

Cause: Leaks in the gas line connection.

Action: Replace the gas cylinder; then pressurize the system. Close, then open the cylinder valve. If the needle on the pressure gauge on the gas cylinder jumps abruptly, a leak in the gas line connection may be indicated. Check all gas line connections.

Too much heat supplied to analyzer.

Cause: Thermocouple or another internal component is damaged or disconnected.

Action: Contact the appropriate service personnel.

A stable TCD baseline cannot be maintained.

Cause A: TCD filaments are contaminated or need to be replaced.

Action A: Contact your Micromeritics service technician about replacing or cleaning the TCD.

Cause B: Possible leak in carrier path.

Action B: Perform leak test in the carrier path.

Cause C: Faulty RTD in one of the temperature zones.

Action C: Access manual mode and check for temperature stability in the temperature zones.

Data collection results in very high or very low peaks that are inconsistent with previous experience.

Cause A: TCD filaments are contaminated or need to be replaced.

Cause B: A different (lower) TCD temperature is being used.

Action B: Repeat the analysis using a higher temperature.

During data collection, a TCD signal of zero is recorded, or no peaks are seen.

Cause A: TCD filaments are contaminated or need to be replaced.

Action A: Contact your Micromeritics service technician about replacing or cleaning the TCD.

Cause B: TCD temperature was not reset after a run automatically suspended.

Action B: Ensure the TCD is re-enabled after all run suspensions.

Furnace will not heat.

Cause A: Furnace not closed and latched.

Action A: Close and latch the furnace.

Cause B: The furnace is not plugged in.

Action B: Plug in the furnace connector.

Cause C: Thermocouple damaged or not plugged in.

Action C: If unplugged, plug in the thermocouple. Replace the thermocouple if necessary.

Pressure will not rise or readings very unstable.

Cause A: Furnace not closed and latched.

Action A: Close and latch the furnace.

Cause B: The furnace is not plugged in.

Action B: Plug in the furnace connector.

ENABLE MANUAL CONTROL

Unit [n] > Enable Manual Control

Use *Enable Manual Control* to enable the manual control of certain system valves and pump components on the analyzer schematic. When this option is enabled, a checkmark appears to the left of **Unit [n] > Enable Manual Control**. If the analyzer schematic is not immediately visible, go to **Unit [n] > Show Instrument Schematic**.

POWER

The **ChemiSorb Auto** is designed to operate with a universal input power supply (100 - 240 VAC) at 50/60 Hz. Noise-free power of the correct voltage and frequency, with a safety earth ground, should be available through a standard wall receptacle. The power outlet should be able to supply 15 amps @ 100 or 120 VAC $\pm 10\%$ or 7.5 amps @ 230 VAC $\pm 10\%$. These requirements can be checked by using a circuit analyzer (available at most hardware or electronic supply houses) or a multimeter. There should also be sufficient outlets for the computer, monitor, printer, and any other peripheral devices.

The instrument should be connected to a switch which meets relevant requirements of IEC 60947-3 or a circuit breaker which meets the relevant requirements of IEC 60947-2.



The analyzer and peripheral devices **must** be installed on their own dedicated power line. Other devices — such as motors, generators, or ovens — **should not** be placed on the same power line.



Replacement power supply cords must be rated for the specifications stated above.



The instrument should be placed so that the power switch and jack are easily accessible. It should not be necessary to move the instrument to make a power connection. The wall outlet should not be blocked, and there should be sufficient space around the outlet and in the immediate area so the instrument can establish a safe and secure power connection and is easily accessible to disconnect the equipment from the AC main power supply.

O-RING COMPATIBILITY

O-ring selection for chemisorption measurements is based on temperature, time, and chemical compatibility. Chemical compatibility should be the first consideration when selecting an appropriate O-ring. The time at which the furnace, and subsequently the sample cell, is at elevated temperature can also affect the performance of the O-rings and should be a secondary consideration. Common O-ring materials include Buna-N (nitrile), Viton (fluoroelastomer), and Kalrez (perfluoroelastomer). Kalrez has historically been used extensively for chemisorption measurements due to compatibility with a wide range of chemicals and temperatures and should be suitable for all applications of the chemisorption option. Viton or Buna-N may also be suitable for analyses similar to the reference material example file. The ability to re-use Buna-N or Viton O-rings may be limited, while the re-use of Kalrez O-rings should be broader. Frequency of use and, potentially, several other factors affect the duration of O-ring use, so rigid rules cannot be specified for these materials. Leak rate and ultimate vacuum levels may be used as indicators for O-ring performance.

RECOVER FROM A POWER FAILURE

The analyzer saves entered and collected data in case of power failure. File parameters and any other data entered will still be present when power is restored. If an analysis was in progress when the power failure occurred, it will be canceled when the analyzer restarts. Any data collected during the analysis will still be present, but the analysis should be restarted in order to produce complete results.

**This page
intentionally
left blank**

11 ANALYSIS TUTORIALS

BET SURFACE AREA

The BET Surface Area evaluates total surface area of the catalyst before and after chemisorption. Loss of activity, which may occur due to the blocking of pores during the chemisorption reaction, as well as the occurrence of sintering of the support, can be studied.

After outgassing the sample, a mixture of 30% nitrogen and 70% helium is applied to the sample which is immersed in a liquid nitrogen (LN₂) bath. The amount of nitrogen adsorbed (usually measured on desorption) at LN₂ temperatures is used to calculate total surface area.

Because nitrogen uptake is a function of pore size, sample sintering can cause results to show reduced surface area. Therefore, it may be helpful to perform BET as the first and last experiments in the analysis in order to check for sintering of the support.

PROCEDURE



Before performing an analysis, ensure the sample and analyzer are adequately prepared.

1. Obtain the sample mass, then install the loaded sample tube and thermocouple on the analyzer.
2. Ensure the *Long Delay Path* is installed in the trap port.
3. Create a sample file containing the appropriate analysis conditions and report options.
 - a. Go to **File > New Sample**.
 - b. Complete the *Sample Description* window using appropriate values.
 - c. Select the *Analysis Conditions* tab.
 - d. Select ChemiSorb Auto in the *View conditions for* drop-down box.
 - e. Insert the following experiment steps. After each step, click **OK** to close each window to move to the next step.

Experiment Steps:

■ **Insert > Experiment**

Description	Enter a description of the experiment
Type of Analysis	Select <i>Physisorption Surface Area</i>

■ **Insert > Instrument Settings**

Gas Flow

Carrier/Reference Gas	Loop, Injection, or Blend Gas
Helium	None
<input type="text" value="50"/> cm ³ STP/min	<input type="text"/> cm ³ STP/min

Flow Path

Blend valve	Loop valve	Analysis valve	Trap valve
<input checked="" type="checkbox"/> Bypass	<input checked="" type="checkbox"/> Fill	<input checked="" type="checkbox"/> Prepare	<input type="checkbox"/> Bypass
<input type="checkbox"/> Blend	<input type="checkbox"/> Inject	<input type="checkbox"/> Analyze	<input checked="" type="checkbox"/> Trap

Temperature

Sample	Rate
<input type="text"/> °C	<input type="text"/> °C/min
<input checked="" type="checkbox"/> Return to ambient temperature	
<input type="checkbox"/> Disable temperature control	

Detector

<input type="checkbox"/> Block temperature	<input type="text" value="100"/> °C
<input type="checkbox"/> Enable detector	
<input type="checkbox"/> Filament temperature	<input type="text" value="245"/> °C

■ **Insert** > **Temperature Ramp**

- Sample ramp**
- End temperature: 350 °C
 - Ramp rate: 50.0 °C/min
 - Hold time: 0 min

■ **Insert** > **Temperature Ramp**

Return to ambient.

■ **Insert** > **Instrument Settings**

Gas Flow

Carrier/Reference Gas	Loop, Injection, or Blend Gas
Nitrogen-Helium	None
<input type="text" value="100"/> cm ³ STP/min	<input type="text"/> cm ³ STP/min

FlowPath

Blend valve	Loop valve	Analysis valve	Trap valve
<input checked="" type="checkbox"/> Bypass	<input checked="" type="checkbox"/> Fill	<input type="checkbox"/> Prepare	<input type="checkbox"/> Bypass
<input type="checkbox"/> Blend	<input type="checkbox"/> Inject	<input checked="" type="checkbox"/> Analyze	<input checked="" type="checkbox"/> Trap

Temperature

Sample	Rate
<input type="checkbox"/> <input type="text"/> °C	<input type="checkbox"/> <input type="text"/> °C/min
<input type="checkbox"/> Return to ambient temperature	
<input checked="" type="checkbox"/> Disable temperature control	

Detector

Block temperature	<input type="text"/> 100	°C
<input checked="" type="checkbox"/> Enable detector		
Filament temperature	<input type="text"/> 245	°C

Insert > Wait

Wait until baseline and temperatures are stable.

Insert > Start Recording

One measurement every 0.1 s.

Insert > Dose

After injection: Wait for 4 minutes.



The application automatically inserts a *Stop Recording* step when a *Start Recording* step is inserted. Ensure that a *Dose* step and a *Temperature Ramp* step is inserted within the *Start/Stop Recording* loop.

- **Termination:** Double-click *Termination* step in the experiment list box (or click *Termination*, then click **Edit**).

Temperature

Sample	Rate
<input type="checkbox"/> <input type="text"/> °C	<input type="checkbox"/> <input type="text"/> °C/min

Temperature (continued)

- Return to ambient temperature
- Disable temperature control

- f. Select the *Report Options* tab and modify the values as needed.
 - g. Click **Save**, then click **Close**.
4. Start the analysis.
- a. Go to **Unit [n] > Sample Analysis** and select the sample file that was just created.
 - b. Edit the sample file as needed, but for this example, editing is not required. Click **Next**.
 - c. From the drop-down list, select the calibrations associated with each experiment in the sample file (if any). For this example, select *None*.
 - d. Click **Next**.
 - e. Read the cautionary window and make any necessary changes. Click **Start** to start the analysis. During the analysis, change the Dewar when prompted.



Change the Dewar rapidly. It is recommended to hold the plastic beaker in one hand and remove the LN₂ Dewar with the other to minimize the time required for the change.

5. When the analysis ends, remove the sample tube from the analyzer, place the caps on the tube, and dry off the outside of the tube with a paper towel.
6. Weigh the sample tube, sample, and caps. Subtract this weight from the weight obtained for the sample tube and caps. The resulting weight is the dry sample weight (the *after analysis weight*). This weight will be used when calculating the BET surface area in the following sections.



Use the cotton gloves provided in the accessory kit when handling heated surfaces. These cotton gloves are not intended to protect hands when heated surfaces are above 60 °C.

GENERATE THE BET REPORT

The following must be performed before generating the BET report:

- Edit the calibration file to ensure that peaks are properly marked.
- Create a TCD calibration file
- Associate the TCD calibration file with the sample file

After completion of these tasks, go to **Reports > Start Report**. Verify that *BET Surface Area* is selected.

EDIT THE PEAKS IN THE CALIBRATION FILE

1. Click **Calibration**.
2. Select the calibration file used with the analysis. Click **OK**.
3. Edit the peaks in the same manner as described for the sample file.

Create the TCD calibration file

1. Go to **Options > Signal Calibration > New**.
2. Select *User defined* and enable an Experiment. Click **OK**.

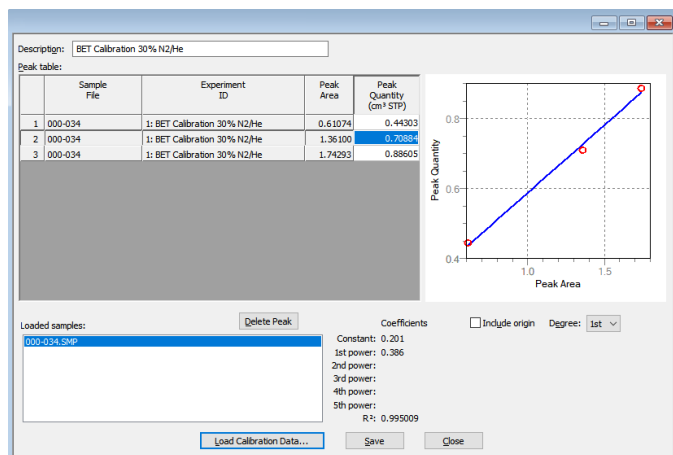
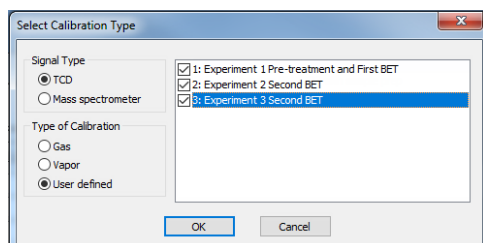

3. Click **Load Calibration Data**.
4. Select the sample file containing the calibration data. Click **OK**. The data in the file are inserted into the appropriate fields of the Signal Calibration window.
5. The values in the *Peak Quantity* column are calculated based on temperatures and pressures measured by the instrument. Values for the volume of each injection at STP can be verified using the formula:
6. The values in the *Peak Quantity* column are defaults. The correct values for the volume of each injection at STP must be determined using the formula:

$$V_{\text{STP}} = V(\text{injected}) \left(\frac{273.15}{273.15 + \text{ambient temp}} \right) \times \left(\frac{\text{ambient pressure}}{760 \text{mmHg}} \right)$$

Determine the volumes for each calibration peak listed in the table.

7. Assess the Peak Area plot, Goodness of Fit, and Coefficients to decide if the calibration file is acceptable. Use your laboratory's standards to determine what level of linearity is acceptable. As a general guideline, use a calibration file with a very low value for Goodness of Fit (less than 0.1), when 1st or 2nd Degree is specified.

To delete peaks that are outliers, highlight the peak data in the table and click **Delete Peak**. Evaluate the results when changing the degree (select a different degree from the drop-down list).

8. Enter a new description into the *Description* field.
9. When satisfied with all values in the file, click **Save**, then click **Close**

Associate the Calibration file with the Sample file

1. Open the Peak Editor.
2. Select the *Peak Editor* experiment from the view selector drop-down list at the bottom of the window.
3. Select the experiment and click the **Calibration** button.
4. Select the down-arrow to the right of the *Calibration* field. Select the calibration file just created. Click **OK**.
5. Repeat steps 3 and 4 for each experiment.
6. Click **Save**, then click **Close**.

BET USER CALIBRATION

CALIBRATION

BET experiments require a separate calibration. If using a pre-blended nitrogen/helium cylinder, the calibration consists of three manual injections of nitrogen through the septum. The optional external septum should be connected to the loop vent port to collect the required gas. If using the internal blend valve with pure nitrogen and helium, a standard gas calibration must be performed. Calibrations can be performed either before or after the BET analysis. As with all TCD calibrations, use the Peak Editor to associate the calibration file with the analysis file. For this reason, it is necessary that the data on the manual injections are collected in a separate experiment from the BET experiment. The injections may be included in the same analysis as the BET experiment, or they may be performed as a completely separate analysis. Use the same recording options (zero, invert) for the Calibration experiment and the BET experiment.

PREPARATION

Pretreatment	Flow helium over the sample to remove impurities, usually at the maximum temperature tolerated by the sample (for example, the temperature at which the sample was calcined).
Analysis	Flow 30% N ₂ /He, using a Dewar of liquid nitrogen, to measure the uptake of nitrogen. Then remove the LN ₂ Dewar. The amount of N ₂ desorbed is measured and the BET equation is used to calculate the active surface area.
Trap	Install the external long delay path. Do not use a cold trap Dewar.
Pressure regulator	For BET analysis, gas cylinders should be set to a level between 14 and 16 psig (95 and 110 kPag).
Furnace temperature	During pretreatment, select a temperature high enough to remove contaminants or moisture, but not so high as to cause sintering or fusing of the sample. Hold the temperature long enough to remove contaminants or moisture. Maintain the target temperature for at least 30 minutes to ensure adequate degassing.

INJECTION SIZE

Inject three volumes of gas with the goal of approximating the volume of gas taken up by the sample. Use one injection slightly larger than the expected volume, one injection slightly smaller than the expected volume, and one injection between these two volumes. The largest injection should be two to three times greater than the smallest injection.

Because the same syringe must be used for all three injections, select a syringe that can accommodate all three injection volumes. The volume of gas uptake can be estimated if the approximate surface area (SA) of the sample is known. Use the following formula to determine the approximate volume (V_m) to inject.

$$V_m(\text{cm}^3 \text{ STP}) = \frac{SA(\text{m}^2)}{(6.023 \times 10^{23} \text{ molecule/mole})(16.21 \times 10^{-20} \text{ m}^2/\text{molecule})} \times 22414 \text{ cm}^3/\text{mole}$$

So:

$$V_m(\text{cm}^3 \text{ STP}) = SA(\text{m}^2) \times 0.229$$

For example, a sample of 0.1 g of 50 m²/g material has a surface area of 5 m². Therefore, the volume of the gas which will be adsorbed is approximately 1.145 cm³ STP.

PROCEDURE



Before performing an analysis, ensure the sample and analyzer are adequately prepared.

1. Obtain the sample mass, then install the loaded sample tube and thermocouple on the analyzer.
2. Ensure the *Long Delay Path* is installed in the trap port.
3. Create a sample file containing the appropriate analysis conditions and report options.
 - a. Go to **File > New Sample**.
 - b. Complete the *Sample Description* window using appropriate values.
 - c. Select the *Analysis Conditions* tab.
 - d. Select *ChemiSorb Auto* in the *View conditions for* drop-down box.
 - e. Insert the following experiment steps. After each step, click **OK** to close each window to move to the next step.

Experiment Steps:



To include the calibration data collection (three manual injections through the septum) within this analysis but as a separate experiment, also insert the following steps (before the *Dose* step):

■ **Insert > Experiment**

Description	Enter a description of the experiment
Type of analysis	<i>Other</i>

■ **Insert > Instrument Settings**

Gas Flow

Carrier/Reference Gas	Loop, Injection, or Blend Gas
Nitrogen-Helium	None
<input type="text" value="50"/> cm ³ STP/min	<input type="text"/> cm ³ STP/min

Flow Path

Blend valve	Loop valve	Analysis valve	Trap valve
<input checked="" type="checkbox"/> Bypass	<input checked="" type="checkbox"/> Fill	<input type="checkbox"/> Prepare	<input type="checkbox"/> Bypass
<input type="checkbox"/> Blend	<input type="checkbox"/> Inject	<input checked="" type="checkbox"/> Analyze	<input checked="" type="checkbox"/> Trap

Temperature

Sample	Rate
<input type="text"/> °C	<input type="text"/> °C/min
<input checked="" type="checkbox"/> Return to ambient temperature	
<input type="checkbox"/> Disable temperature control	

Detector

Block temperature	<input type="text" value="100"/>	°C
<input checked="" type="checkbox"/> Enable detector		
Filament temperature	<input type="text" value="245"/>	°C

■ **Insert > Wait**

Wait until baseline and temperatures are stable.

■ **Insert > Start Recording**

One measurement every 0.1 s.

■ **Insert > Start Repeat**

Repeat 3 times

■ **Insert > Wait**

Wait for operator. In text box enter: *Prepare manual N₂ injection*. Click OK.

■ **Insert > Wait**

Wait for 4 minutes. Click OK.



- The application automatically inserts a *Stop Repeat* step when a *Start Repeat* step is inserted. Ensure that a *Wait* step is inserted within the *Start/Stop Repeat* loop.
- The application automatically inserts a *Stop Recording* step when a *Start Recording* step is inserted. Ensure that the *Dose* step and the *Start Repeat/Wait/Dose/Stop Repeat* step is inserted within the *Start/Stop Record* loop.

- Select the *Report Options* tab and modify the values as needed.
 - Click **Save**, then click **Close**.
4. Start the analysis.
- Go to **Unit [n] > Sample Analysis** and select the sample file that was just created.
 - Edit the sample file as needed, but for this example, editing is not required. Click **Next**.
 - From the drop-down list, select the calibrations associated with each experiment in the sample file (if any). For this example, select *None*.
 - Click **Next**.
 - Read the cautionary window and make any necessary changes. Click **Start** to start the analysis. During the analysis, change the Dewar when prompted.



Change the Dewar rapidly. It is recommended to hold the plastic beaker in one hand and remove the LN₂ Dewar with the other to minimize the time required for the change.

- When the analysis ends, remove the sample tube from the analyzer, place the caps on the tube, and dry off the outside of the tube with a paper towel.
- Weigh the sample tube, sample, and caps. Subtract this weight from the weight obtained for the sample tube and caps. The resulting weight is the dry sample weight (the *after analysis weight*). This weight will be used when calculating the BET surface area in the following sections.



Use the cotton gloves provided in the accessory kit when handling heated surfaces. These cotton gloves are not intended to protect hands when heated surfaces are above 60 °C.

LOOP CALIBRATION FOR TCD ANALYZERS TUTORIAL

[Septum on page 8-17](#)

Each calibration loop must be calibrated prior to its first use to determine its precise volume under local conditions. Calibration consists of:

- Determining the average area of a series of peaks generated by injections of a known volume of gas through the analyzer septum using a syringe.
- Determining the average area of a series of peaks generated by injections of the same gas using the analyzer's internal loop.
- Calculating the volume of the loop by comparing the average peak area generated by the loop injections with that generated by the syringe injections.
- Entering the calculated loop volume under **Unit [n] > Unit Configuration**.

STEP 1: CREATE A SAMPLE FILE

Create the sample file and insert a *Loop Calibration* experiment on the *Analysis Conditions* tab.

STEP 2: PERFORM THE ANALYSIS

1. Install the correct injection loop.
2. Go to **Unit > Sample Analysis** and select the sample file for the loop calibration.
3. Click **Next** to accept the default values, then click **Start**.
4. Inject 100% of the loop volume. (The default is 0.5 ml.) For example, if calibrating the 1 cm³ loop, inject as close to 1.0 cm³ of gas as possible.



Pay close attention to the instructions provided in each prompt and perform the steps in the order given. Most accurate data results from keeping injection size as consistent as possible. Injection errors may be evident in the data and may make it necessary to repeat the experiment.

After the last manual injection, the analyzer automatically makes the same number of injections using the loop.

STEP 3: GENERATE THE REPORT

[Peak Editor on page 6 - 2](#)

When properly performed, each manual and automatic injection results in a peak. When the *Results* view of the *Start Analysis* window is selected, each peak can be viewed as it is collected. The area under the peak corresponds to the amount of gas injected.

1. Go to **File > Open > [.SMP]**. Open the .SMP file containing the calibration experiment. Verify the defined peaks are properly marked (or correct them) using the *Peak Editor*.
2. On the *Reports* tab, select only the *Loop Calibration* report option. Click *Preview* to view the results, including the *Loop Volume*.
3. Go to **Unit [n] > Unit Configuration**.
4. In the *Loop Volume* field, enter the *Loop Volume*.

GENERATE THE PULSE CHEMISORPTION REPORT

[Peak Editor on page 6 - 2](#)

Open the Peak Editor and ensure that peaks are properly marked.

There are three possibilities for each dose of gas injected during Pulse chemisorption :

- all of the gas is taken up by the sample,
- some of the gas is taken up by the sample, or
- none of the gas is taken up by the sample.

When pulse chemisorption is properly performed, there will be some injections of each type. When the data is viewed using the Peak Editor, however, only those injections in which some or none of the gas is taken up will appear as peaks. When all of the gas is taken up by the sample, none of it reaches the detector and, therefore, the peak area is zero. These types of peaks are detected automatically by the application and do not require marking.

1. Go to **File > Open > .SMP file**.
2. Select the sample file used with this analysis. Click **OK**.
3. On the Sample Description tab, click **Active Metals**.
4. Verify that the *Stoichiometry Factor* and the *% of Sample Mass* values are correct.
5. Click **OK**.
6. Open the *Peak Editor* and click **Calibration**.
7. Verify that the values for the loop (or manual injection) volume, ambient temperature, atmospheric pressure, and active concentration are accurate.
8. Go to **Report Options > Pulse Chemisorption** to set the report options. Click **OK**, then click *Preview* to preview the report, or go to **Reports > Start Report > SMP file** to generate the report.

LOOP VOLUME CALIBRATION ANALYSIS TUTORIAL

It is preferred for the sample to require at least two doses of gas, but no more than ten doses, before the reaction ends — depending on the environment. Some factors that influence the number of doses required are sample size, the active surface area per unit of sample, and the size of the loop. If the pulse chemisorption analysis requires more doses or fewer doses, change either the sample size or the loop size.

Three loops of different sizes are available with the analyzer. 0.5cc is included with the instrument. Also available (but not included) are 1.0cc and 5.0cc. The loop must be calibrated prior to use. As an alternative to replacing the loop, the loop volume may be changed by adjusting its temperature. If the loop volume is changed by changing its temperature, results will be more accurate if the loop volume is recalibrated at the new temperature.

LOOP CALIBRATION

Before data from an analysis that uses an injection loop can be reduced, a loop calibration experiment must be performed. An independent loop calibration can be performed either before or after the analysis.

The following example assumes that the loop calibration will be performed after the analysis. A *Loop Calibration* step can be included in a pulse chemisorption analysis.

PREPARATION

Pretreatment	Degas by flowing inert gas (such as helium, argon, or nitrogen) over the sample while ramping the temperature.
Analysis	Pulse the loop gas over the sample until the peak area remains constant.
Trap	No trap is needed during pretreatment. During the analysis, use the trap fixture with a Dewar of water in place as a short delay path. This delay compensates for the flow disturbance caused by each loop injection.
Pressure regulator	Gas cylinders should be set to a level between 14 and 16 psig (95 and 110 kPag).
Furnace temperature	Select a temperature high enough to remove any contaminants or moisture, but not so high as to cause sintering or fusing of the sample. Ensure the <i>Done</i> step is set to return the sample temperature to ambient.

PULSE CHEMISORPTION ANALYSIS TUTORIAL

A Pulse chemisorption analysis determines metallic active surface area, percent metal dispersion, and active particle size by applying measured pulses of reactant gas to the sample, depending upon what technique is used. Pulse chemisorption is performed in the same manner as TPD, except that the sample is dosed with the analysis gas using the injection loop until each active site has reacted. After the active sites have completely reacted, the discretely injected gas volumes emerge unchanged. If TPD is performed after Pulse chemisorption, additional information about the distribution of active sites and the strength of active sites is collected.

The amount chemisorbed is the difference between the total amount of reactant gas injected and the amount that did not react with the active sites of the sample. The size of each pulse is determined by the loop, which is located on an electrically operated valve.

PROCEDURE



In the following example, Pulse chemisorption is performed on a sample of Pt/Al₂O₃ with 10% CO/He. Alter the analysis conditions to accommodate a different analysis.



Before performing an analysis, ensure the sample and analyzer are adequately prepared. See [Prepare for Analysis on page 5 - 5](#).

1. Obtain the sample mass, then install the loaded sample tube and thermocouple on the analyzer. Close the furnace around the sample tube.
2. Create a sample file containing the appropriate analysis conditions and report options.
 - a. Go to **File > New Sample**.
 - b. Complete the *Sample Description* window using appropriate values.
 - c. Select the *Analysis Conditions* tab.
 - d. Select *ChemiSorb Auto* in the *View conditions for* drop-down box.
 - e. Insert the following experiment steps. After each step, click **OK** to close each window to move to the next step.

Experiment Steps:

■ **Insert > Experiment**

Description	Enter a description of the experiment
Type of Analysis	Select <i>Pulse</i>

■ **Insert > Instrument Settings**

Gas Flow

Carrier/Reference Gas	Loop, Injection, or Blend Gas
Helium	None
<input type="text" value="50"/> cm ³ STP/min	<input type="text"/> cm ³ STP/min

Flow Path

Blend valve	Loop valve	Analysis valve	Trap valve
<input checked="" type="radio"/> Bypass	<input checked="" type="radio"/> Fill	<input checked="" type="radio"/> Prepare	<input checked="" type="radio"/> Bypass
<input type="radio"/> Blend	<input type="radio"/> Inject	<input type="radio"/> Analyze	<input type="radio"/> Trap

Temperature

Sample	Rate
<input type="text"/> °C	<input type="text"/> °C/min
<input type="checkbox"/> Disable temperature control <input type="checkbox"/> Return to ambient temperature	

Detector

<input type="checkbox"/> Block temperature	<input type="text" value="100"/> °C
<input type="checkbox"/> Enable detector	
<input type="checkbox"/> Filament temperature	<input type="text" value="245"/> °C

■ **Insert** > **Temperature Ramp**

Sample Ramp:

End temperature: 400.0 °C

Ramp rate: 10.0 °C /min

Hold time: 30.0 min

■ **Insert** > **Instrument Settings**

Gas Flow

Carrier/Reference Gas	Loop, Injection, or Blend Gas
Hydrogen-Argon	None
<input type="text" value="50"/> cm ³ STP/min	<input type="text"/> cm ³ STP/min

Blend valve	Loop valve	Analysis valve	Trap valve
<input checked="" type="checkbox"/> Bypass	<input checked="" type="checkbox"/> Fill	<input checked="" type="checkbox"/> Prepare	<input checked="" type="checkbox"/> Bypass
<input type="checkbox"/> Blend	<input type="checkbox"/> Inject	<input type="checkbox"/> Analyze	<input type="checkbox"/> Trap

Temperature

Sample	Rate
<input checked="" type="checkbox"/> 400 °C	<input type="checkbox"/> 10.0 °C/min
<input type="checkbox"/> Disable temperature control	
<input checked="" type="checkbox"/> Return to ambient temperature	

Detector

<input type="checkbox"/> Block temperature	100 °C
<input type="checkbox"/> Enable detector	
<input type="checkbox"/> Filament temperature	245 °C

■ **Insert > Wait**

Wait 30 min.

■ **Insert > Instrument Settings**

Gas Flow

Carrier/Reference Gas	Loop, Injection, or Blend Gas
Helium	Carbon-Monoxide - Helium
<input type="checkbox"/> 50 cm ³ STP/min	<input type="checkbox"/> 20 cm ³ STP/min

Flow Path

Blend valve	Loop valve	Analysis valve	Trap valve
<input checked="" type="checkbox"/> Bypass	<input checked="" type="checkbox"/> Fill	<input type="checkbox"/> Prepare	<input checked="" type="checkbox"/> Bypass
<input type="checkbox"/> Blend	<input type="checkbox"/> Inject	<input checked="" type="checkbox"/> Analyze	<input type="checkbox"/> Trap

Temperature

Sample	Rate
<input type="checkbox"/> 400.0 °C	<input type="checkbox"/> 10 °C/min

Temperature (continued)

<input type="checkbox"/>	Return to ambient temperature
<input type="checkbox"/>	Disable temperature control

Detector

<input type="checkbox"/>	Block temperature	100	°C
<input checked="" type="checkbox"/>	Enable detector		
<input type="checkbox"/>	Filament temperature	245	°C

- **Insert > Temperature Ramp**

Return to ambient.

- **Insert > Wait**

Wait until baseline and temperature are stable.

- **Insert > Wait**

Wait 5 minutes.

- **Insert > Start Recording**

One measurement every 0.1 s

- **Insert > Start Repeat**

Repeat until peaks are equal or 10 times.

- **Insert > Dose**

Wait for 2.00 minutes, then wait for a return to baseline.



- The application automatically inserts a *Stop Repeat* step when a *Start Repeat* step is inserted. Ensure that a *Dose* step is inserted within the *Start/Stop Repeat* loop.
- The application automatically inserts a *Stop Recording* step when a *Start Recording* step is inserted. Ensure that the *Dose* step is inserted within the *Start/Stop Record* loop.

- **Termination:** Double click *Termination* step in the experiment list box (or click *Termination*, then click **Edit**).

Temperature

Sample	Rate
<input type="text"/> °C	<input type="text"/> °C/min
<input checked="" type="checkbox"/> Return to ambient temperature	
<input type="checkbox"/> Disable temperature control	

Detector

Block temperature	<input type="text"/> 100	°C
<input type="checkbox"/> Enable detector		
Filament temperature	<input type="text"/> 245	°C

- Select the *Report Options* tab and modify values as needed.
 - Click **Save**, then click **Close**.
- Start the analysis.
 - Go to **Unit > Sample Analysis**. From the *Files* list box, select the sample file created in the previous step. Edit the file as needed. Click **Next**.
 - From the drop-down list, select the calibrations associated with each experiment in the sample file (if any). For this example, select *None*. Click **Next**.



Calibration files can also be associated with a sample file after analysis using **Calibration** button in the Peak Editor.

- Read the cautionary window and make any necessary changes.
- Click **Start** to start the analysis.

When the analysis ends, the furnace begins to lower the sample to room temperature. To speed cooling of the sample, use the optional CryoCooler



Use the cotton gloves provided in the accessory kit when handling heated surfaces. These cotton gloves are not intended to protect hands when heated surfaces are above 60 °C.

When the displayed sample temperature reaches the ambient temperature, open the furnace. Using gloves, remove the sample tube.

TEMPERATURE PROGRAMMED DESORPTION ANALYSIS TUTORIAL



This topic provides an example of how to perform a Temperature Programmed Desorption analysis using NH_3 on zeolite under helium with a $10\text{ }^\circ\text{C}/\text{min}$ temperature ramp. Make the appropriate modifications for the material being analyzed.

Temperature Programmed Desorption (TPD) analyses determine the quantity, type, and strength of active sites available on the surface of a catalyst from measurement of the amount of gas desorbed at various temperatures.

After the sample has been outgassed, reduced, or otherwise prepared, a steady stream of analysis gas flows over the sample and reacts with the active sites. (Alternatively, Pulse chemisorption can be used to react with active sites.) Programmed desorption begins when the temperature is ramped linearly over time while a constant stream of inert carrier gas passes over the sample.

At a certain temperature, the heat will overcome the activation energy, breaking the bond between the adsorbate and adsorbent. The adsorbed species will then desorb. If different active metals are present, they usually will desorb the reacted species at different temperatures. The desorbed molecules enter the stream of inert carrier gas and are swept to the detector where the detector response is proportional to the gas concentrations. The quantity of desorbed species, combined with the stoichiometry factor, and the temperature at which pre-adsorbed species desorb, yield the quantity and strength of active sites, respectively.

If TPD is performed after coverage of the active sites by flow or pulse chemisorption, additional information about the distribution of active sites and the strength of active sites is collected.

PREPARATION



Before performing an analysis, ensure the sample and analyzer are adequately prepared. See [Prepare for Analysis on page 5 - 5](#).

Pretreatment	Degas by flowing inert gas — such as helium, argon, or nitrogen — over the sample while ramping the temperature.
Analysis	Choose a gas mixture from the following table based on the needed results. Flow the gas over the sample, then ramp the temperature beginning at ambient.
Trap	Not required

Needed Results	Carrier Gas	Analysis Gas
Acidity	helium	ammonia (10% maximum NH ₃ , blended in helium)
Basicity	helium	Carbon dioxide (10% CO ₂ , blended in Helium)



Before performing an analysis, ensure the sample and analyzer have been adequately prepared.

PROCEDURE

These instructions analyze zeolite with ammonia (use 10% NH₃ blended in helium) at 3 to 20 °C/min. Adjust the values in the example to accommodate the analysis you are performing.

- Obtain the sample weight, then install the loaded sample tube and thermocouple on the analyzer. Close the furnace around the sample tube.
- Create a sample file containing the appropriate analysis conditions and report options.
 - Go to **File > New Sample**.
 - Complete the *Sample Description* window using appropriate values.
 - Select the *Analysis Conditions* tab.
 - Select *ChemiSorb Auto* in the *View conditions for* drop-down box.
 - Insert the following experiment steps. After each step, click **OK** to close each window to move to the next step.

Experiment Steps:

■ ***Insert > Experiment***

Description Enter a description of the experiment
Type of Analysis Select *Other*

■ ***Insert > Instrument Settings***

Gas Flow

Carrier/Reference Gas	Loop, Injection, or Blend Gas
Helium	None
<input type="text" value="50"/> cm ³ STP/min	<input type="text"/> cm ³ STP/min

Flow Path

Blend valve	Loop valve	Analysis valve	Trap valve
<input checked="" type="radio"/> Bypass	<input checked="" type="radio"/> Fill	<input checked="" type="radio"/> Prepare	<input checked="" type="radio"/> Bypass
<input type="radio"/> Blend	<input type="radio"/> Inject	<input type="radio"/> Analyze	<input type="radio"/> Trap

Temperature

Sample	Rate
<input type="text"/> °C	<input type="text"/> °C/min
<input checked="" type="radio"/> Return to ambient temperature	
<input type="radio"/> Disable temperature control	

Detector

<input type="checkbox"/> Block temperature	<input type="text" value="100"/> °C
<input type="checkbox"/> Enable detector	
<input type="checkbox"/> Filament temperature	<input type="text" value="245"/> °C

■ ***Insert > Temperature Ramp***

Sample ramp

- End temperature: 350 °C
- Ramp rate: 20 °C/min
- Hold time: 10 min

■ ***Insert > Temperature Ramp***

Return to ambient

■ **Insert > Instrument Settings**

Gas Flow

Carrier/Reference Gas	Loop, Injection, or Blend Gas
Ammonia-Helium	None
<input type="text" value="50"/> cm ³ STP/min	<input type="text"/> cm ³ STP/min

Flow Path

Blend valve	Loop valve	Analysis valve	Trap valve
<input checked="" type="radio"/> Bypass	<input checked="" type="radio"/> Fill	<input checked="" type="radio"/> Prepare	<input checked="" type="radio"/> Bypass
<input type="checkbox"/> Blend	<input type="checkbox"/> Inject	<input type="checkbox"/> Analyze	<input type="checkbox"/> Trap

Temperature

Sample	Rate
<input type="text"/> °C	<input type="text"/> °C/min
<input checked="" type="checkbox"/> Return to ambient temperature	
<input type="checkbox"/> Disable temperature control	

Detector

<input type="checkbox"/> Block temperature	<input type="text" value="100"/> °C
<input type="checkbox"/> Enable detector	
<input type="checkbox"/> Filament temperature	<input type="text" value="245"/> °C

■ **Insert > Wait**

Wait **60 minutes**.

■ **Insert > Instrument Settings**

Gas Flow

Carrier/Reference Gas	Loop, Injection, or Blend Gas
Helium	None
<input type="text" value="50"/> cm ³ STP/min	<input type="text"/> cm ³ STP/min

Flow Path

Blend valve	Loop valve	Analysis valve	Trap valve
-------------	------------	----------------	------------

Flow Path (continued)

<input checked="" type="checkbox"/> Bypass	<input checked="" type="checkbox"/> Fill	<input type="checkbox"/> Prepare	<input checked="" type="checkbox"/> Bypass
<input type="checkbox"/> Blend	<input type="checkbox"/> Inject	<input checked="" type="checkbox"/> Analyze	<input type="checkbox"/> Trap

Temperature

Sample	Rate
<input type="text"/> °C	<input type="text"/> °C/min
<input checked="" type="checkbox"/> Return to ambient temperature	
<input type="checkbox"/> Disable temperature control	

Detector

Block temperature	<input type="text"/> 100	°C
<input checked="" type="checkbox"/> Enable detector		
Filament temperature	<input type="text"/> 245	°C

- **Insert > Wait**

Wait **60 minutes**.

- **Insert > Wait**

Wait until baseline and temperatures are stable.

- **Insert > Start Recording**

One measurement every **1.0 s**

- **Insert > Temperature Ramp**

- Sample ramp**
- End temperature: 350 °C
 - Ramp rate: 10 °C/min
 - Hold time: 30 min



The application automatically inserts a *Stop Recording* step when a *Start Recording* step is inserted. Ensure that the *Temperature Ramp* step is inserted within the *Start/Stop Record* loop.

- **Insert > Temperature Ramp**

Return to ambient.



Create a new experiment and repeat the steps from the yellow highlighted step (shown previously) to here for each repetition..

- **Termination:** Double click *Termination* step in the experiment list box (or click *Termination*, then click **Edit**).

Temperature

Sample	Rate
<input type="text"/> °C	<input type="text"/> °C/min
<input checked="" type="checkbox"/> Return to ambient temperature	
<input type="checkbox"/> Disable temperature control	

Detector

<input type="checkbox"/> Block temperature	<input type="text" value="100"/> °C
<input type="checkbox"/> Enable detector	
<input type="checkbox"/> Filament temperature	<input type="text" value="245"/> °C

- f. Select the *Report Options* tab and set the values. Click **Save** then click **Close**.
3. Start the analysis.
 - a. Go to **Unit > Sample Analysis**. From the *Files* list box, select the sample file created in the previous step. Edit the file as needed. Click **Next**.
 - b. From the drop-down list, select the calibrations associated with each experiment in the sample file (if any). For this example, select *None*. Click **Next**.
 - c. Read the cautionary window and make any necessary changes.
 - d. Click **Start** to start the analysis.



When the analysis ends, the furnace begins to lower the sample to room temperature. To speed cooling of the sample, use the optional CryoCooler or AutoCool. Remove the sample tube when the analysis is complete.



Use the cotton gloves provided in the accessory kit when handling heated surfaces. These cotton gloves are not intended to protect hands when heated surfaces are above 60 °C.

TEMPERATURE PROGRAMMED OXIDATION ANALYSIS TUTORIAL



This topic provides an example of performing a TPO on WO_3 . Because TPR is often used as the preparation for TPO, the TPR process was included in this example.

Temperature Programmed Oxidation (TPO) examines the extent to which a catalyst can be re-oxidized. Generally, TPO analyses are used to measure the degree of reduction of certain oxides.

Usually, the sample is pretreated, and the metal oxides are reduced to the base metal. Then the reactant gas is applied to the sample in pulses or (alternatively) as a steady stream. The analyzer measures the uptake of the reactant gas.

TPO is often performed after TPR is performed. When the TPR experiment concludes, the sample is returned to room temperature. Then, the analysis gas is changed to 2-5% O_2 /He. This gas mixture is flowed after the sample is at ambient temperature, then the temperature is ramped up to the same maximum temperature used for the preceding TPR analysis. The portion of the sample that had been reduced is re-oxidized, and the degree of reduction can be calculated.

If the TPR and TPO results are different, there are several possible causes: the sample material sintered such that only a surface oxide (and not a bulk oxide) is formed, or part of the sample was re-oxidized at room temperature while the TCD baseline was stabilizing.



When using any mixture of gases for TPR or TPO analyses, make sure the thermal conductivities of the two gases in the mixture are quite different for maximum sensitivity, See [Gas Charts on page C - 1](#).

PREPARATION

Pretreatment	TPR
Analysis	2 to 5% oxygen/helium is flowed through the sample while temperature is ramped, beginning at ambient temperature.
Trap	Not required.



Before performing an analysis, ensure the sample and analyzer are adequately prepared. See [Prepare for Analysis on page 5 - 5](#).

PROCEDURE

1. Obtain the sample weight, then install the loaded sample tube and thermocouple on the analyzer. Close the furnace around the sample tube.
2. Create a sample file containing the appropriate analysis conditions and report options.
 - a. Go to **File > New Sample**.
 - b. Complete the *Sample Description* window using appropriate values.
 - c. Select the *Analysis Conditions* tab.
 - d. Select *ChemiSorb Auto* in the *View conditions for* drop-down box.
 - e. Insert the following experiment steps. After each step, click **OK** to close each window to move to the next step.

Experiment Steps:

■ **Insert > Experiment**

Description Enter a description of the experiment
Type of Analysis Select *Temperature Programmed*

■ **Insert > Instrument Settings**

Gas Flow

Carrier/Reference Gas	Loop, Injection, or Blend Gas
Helium	None
<input type="text" value="50"/> cm ³ STP/min	<input type="text"/> cm ³ STP/min

Flow Path

Blend valve	Loop valve	Analysis valve	Trap valve
<input checked="" type="radio"/> Bypass	<input checked="" type="radio"/> Fill	<input checked="" type="radio"/> Prepare	<input type="checkbox"/> Bypass
<input type="checkbox"/> Blend	<input type="checkbox"/> Inject	<input type="checkbox"/> Analyze	<input checked="" type="radio"/> Trap

Temperature

Sample	Rate
<input type="text"/> °C	<input type="text"/> °C/min
<input type="checkbox"/> Return to ambient temperature	
<input checked="" type="radio"/> Disable temperature control	

Detector

Block temperature	100	°C
<input type="checkbox"/> Enable detector		
Filament temperature	245	°C

- **Insert > Temperature Ramp**

Return to ambient.

- **Insert > Instrument Settings**

Gas Flow

Carrier/Reference Gas	Loop, Injection, or Blend Gas
Hydrogen-Argon	None
<input type="text" value="50"/> cm ³ STP/min	<input type="text"/> cm ³ STP/min

Flow Path

Blend valve	Loop valve	Analysis valve	Trap valve
<input checked="" type="checkbox"/> Bypass	<input checked="" type="checkbox"/> Fill	<input type="checkbox"/> Prepare	<input type="checkbox"/> Bypass
<input type="checkbox"/> Blend	<input type="checkbox"/> Inject	<input checked="" type="checkbox"/> Analyze	<input checked="" type="checkbox"/> Trap

Temperature

Sample	Rate
<input type="text"/> °C	<input type="text"/> °C/min
<input checked="" type="checkbox"/> Return to ambient temperature	
<input type="checkbox"/> Disable temperature control	

Detector

Block temperature	100	°C
<input checked="" type="checkbox"/> Enable detector		
Filament temperature	245	°C

- **Insert > Wait**

Wait for operator. Add text: Setup trap and close furnace.

■ **Insert > Wait**

Wait until baseline and temperatures are stable.

■ **Insert > Start Recording**

One measurement every 1.0 s.

■ **Insert > Temperature Ramp**

- Sample ramp**
- End temperature: 980 0 °C
 - Ramp rate: 10.0 °C/min
 - Hold time: 0.0 min



The application automatically inserts a *Stop Recording* step when a *Start Recording* step is inserted. Ensure that the *Temperature Ramp* step is inserted within the *Start/Stop Record* loop.

■ **Insert > Instrument Settings**

Gas Flow

Carrier/Reference Gas	Loop, Injection, or Blend Gas
Helium	None
<input type="text" value="10"/> cm ³ STP/min	<input type="text"/> cm ³ STP/min

Flow Path

Blend valve	Loop valve	Analysis valve	Trap valve
<input checked="" type="radio"/> Bypass	<input checked="" type="radio"/> Fill	<input checked="" type="radio"/> Prepare	<input checked="" type="radio"/> Bypass
<input type="radio"/> Blend	<input type="radio"/> Inject	<input type="radio"/> Analyze	<input type="radio"/> Trap

Temperature

Sample	Rate
<input type="text"/> °C	<input type="text"/> °C/min
<input checked="" type="radio"/> Return to ambient temperature	
<input type="radio"/> Disable temperature control	

Detector

Block temperature	<input type="text" value="100"/>	°C
<input type="checkbox"/> Enable detector		
Filament temperature	<input type="text" value="245"/>	°C

■ **Insert > Experiment**

Description Enter a description of the experiment
Type of Analysis Select *Temperature Programmed Oxidation*

■ **Insert > Instrument Settings**

Gas Flow

Carrier/Reference Gas	Loop, Injection, or Blend Gas
Oxygen-Helium	None
<input type="text" value="50"/> cm ³ STP/min	<input type="text"/> cm ³ STP/min

Flow Path

Blend valve	Loop valve	Analysis valve	Trap valve
<input checked="" type="checkbox"/> Bypass	<input checked="" type="checkbox"/> Fill	<input type="checkbox"/> Prepare	<input checked="" type="checkbox"/> Bypass
<input type="checkbox"/> Blend	<input type="checkbox"/> Inject	<input checked="" type="checkbox"/> Analyze	<input type="checkbox"/> Trap

Temperature

Sample	Rate
<input type="text"/> °C	<input type="text"/> °C/min
<input checked="" type="checkbox"/> Return to ambient temperature	
<input type="checkbox"/> Disable temperature control	

Detector

Block temperature	<input type="text" value="100"/>	°C
<input checked="" type="checkbox"/> Enable detector		
Filament temperature	<input type="text" value="245"/>	°C

■ **Insert > Wait**

Wait until baseline and temperatures are stable.

■ **Insert > Start Recording**

One measurement every 1.0 s

■ **Insert > Temperature Ramp**

- Sample ramp**
- End temperature: 980 °C
 - Ramp rate: 20.0 °C/min
 - Hold time: 0.0 min



The application automatically inserts a *Stop Recording* step when a *Start Recording* step is inserted. Ensure that the *Temperature Ramp* step is inserted within the *Start/Stop Record* loop.

■ **Insert > Instrument Settings**

Gas Flow

Carrier/Reference Gas	Loop, Injection, or Blend Gas
Helium	None
<input type="text" value="10"/> cm ³ STP/min	<input type="text"/> cm ³ STP/min

Flow Path

Blend valve	Loop valve	Analysis valve	Trap valve
<input checked="" type="radio"/> Bypass	<input checked="" type="radio"/> Fill	<input type="checkbox"/> Prepare	<input checked="" type="radio"/> Bypass
<input type="checkbox"/> Blend	<input type="checkbox"/> Inject	<input checked="" type="radio"/> Analyze	<input type="checkbox"/> Trap

Temperature

Sample	Rate
<input type="text"/> °C	<input type="text"/> °C/min
<input checked="" type="radio"/> Return to ambient temperature	
<input type="checkbox"/> Disable temperature control	

Detector

Block temperature	<input type="text" value="100"/> °C
<input type="checkbox"/> Enable detector	
Filament temperature	<input type="text" value="245"/> °C

- **Termination:** Double click *Termination* step in the experiment list box (or click *Termination*, then click **Edit**).

Temperature

Sample	Rate
<input type="text"/> °C	<input type="text"/> °C/min
<input checked="" type="checkbox"/> Return to ambient temperature	
<input type="checkbox"/> Disable temperature control	

Detector

Block temperature	<input type="text" value="100"/>	°C
<input type="checkbox"/> Enable detector		
Filament temperature	<input type="text" value="245"/>	°C

- Select the *Report Options* tab and set the values.
 - Click **Save**, then click **Close**.
- Start the analysis.
 - Go to **Unit > Sample Analysis**. From the *Files* list box, select the sample file created in the previous step. Edit the file as needed. Click **Next**.
 - From the drop-down list, select the calibrations associated with each experiment in the sample file (if any). For this example, select *None*. Click **Next**.
 - Read the cautionary window and make any necessary changes.
 - Click **Start** to start the analysis.



When the analysis ends, the furnace begins to lower the sample to room temperature. To speed cooling of the sample, use the optional CryoCooler or AutoCool. Remove the sample tube when the analysis is complete.

- As the temperature increases, the sample is oxidized, and the application calculates the volume of oxygen taken up.
- Allow the TCD signal to return to the initial baseline after the peak has been displayed
- When the displayed sample temperature reaches the ambient temperature, open the furnace. Using gloves, remove the sample tube.



Use the cotton gloves provided in the accessory kit when handling heated surfaces. These cotton gloves are not intended to protect hands when heated surfaces are above 60 °C.

TEMPERATURE PROGRAMMED REDUCTION ANALYSIS TUTORIAL



This topic provides an example of how to perform a TPR analysis of copper oxide. Copper Oxide Reference Material can be ordered from Micromeritics. Parts and accessories are located on the [Micromeritics](#) web page.



Some reactions begin at temperatures below ambient. In such cases, a Dewar containing an appropriate coolant should be used instead of the furnace at the beginning of the experiment. For example, reduction of PtO should begin at approximately -50 °C, because the reaction begins at about -30 °C. Alternatively, the optional CryoCooler can be used.

Temperature Programmed Reduction (TPR) determines the number of reducible species present in the catalyst and reveals the temperature at which reduction occurs. An important aspect of TPR analyses is that the sample need not have special characteristics other than containing reducible metals.

The TPR analysis begins by flowing analysis gas (typically hydrogen in an inert carrier gas such as nitrogen or argon) over the sample, usually starting at ambient temperature. While the gas is flowing, the temperature of the sample is increased linearly with time and the consumption of hydrogen by adsorption/reaction is monitored. Changes in the concentration of the gas mixture are determined. This information yields the hydrogen uptake volume.

PREPARATION

Pretreatment	Oxidize by flowing O ₂ over the sample.
Analysis	Flow 5-10% hydrogen/argon while ramping the temperature. The analyzer records hydrogen consumption as a function of temperature. Nitrogen is sometimes used because it may be more economical than argon. Argon is recommended over nitrogen because the resultant peak(s) show no reaction between sample and gas.
Trap	A sorption or cold trap is required to remove traces of water formed as a product of the reduction.



Before performing an analysis, ensure the sample and analyzer are adequately prepared. See [Prepare for Analysis on page 5 - 5](#).

PROCEDURE

1. Obtain the sample mass then install the loaded sample tube on the analyzer. If the analysis begins below ambient, either place a Dewar of coolant around the sample tube or close the furnace around the sample tube and install the CryoCooler. If the analysis begins at ambient, close the furnace around the sample tube.
2. Ensure that the zeolite adsorbent has been regularly activated and that it is at room temperature.
3. If using the optional cold trap instead of the sorption trap, install it then place a Dewar filled with coolant around the cold trap. Ensure that the Dewar contains sufficient coolant to cover the cold trap loops.

A mixture of isopropyl alcohol (IPA) and liquid nitrogen (LN₂) is the recommended coolant for this experiment. Place the isopropyl alcohol in a Dewar and slowly pour LN₂ into the Dewar while stirring the mixture. Continue to add and stir the mixture until it becomes a slush. The mixture must be capable of achieving a temperature of about -90 °C.



Extreme caution should be used when mixing the IPA/LN₂. See [Dewar Precautions on page 5 - 3](#).

4. Create a sample file containing the appropriate analysis conditions and report options.
 - a. Go to **File > New Sample**.
 - b. Complete the *Sample Description* window using appropriate values.
 - c. Select the *Analysis Conditions* tab.
 - d. Select *ChemiSorb Auto* in the *View conditions for* drop-down box.
 - e. Insert the following experiment steps. After each step, click **OK** to close each window to move to the next step.

Experiment Steps:

■ **Insert > Experiment**

Description Enter a description of the experiment
Type of Analysis Select *Temperature Programmed*

■ **Insert > Instrument Settings**

Gas Flow

Carrier/Reference Gas	Loop, Injection, or Blend Gas
Argon	Hydrogen
<input type="text" value="45"/> cm ³ STP/min	<input type="text" value="5"/> cm ³ STP/min

Flow Path

Blend valve	Loop valve	Analysis valve	Trap valve
<input checked="" type="checkbox"/> Bypass	<input checked="" type="checkbox"/> Fill	<input type="checkbox"/> Prepare	<input type="checkbox"/> Bypass
<input type="checkbox"/> Blend	<input type="checkbox"/> Inject	<input checked="" type="checkbox"/> Analyze	<input checked="" type="checkbox"/> Trap

Temperature

Sample	Rate
<input type="checkbox"/> <input type="text"/> °C	<input type="checkbox"/> °C/min
<input checked="" type="checkbox"/> Return to ambient temperature	
<input type="checkbox"/> Disable temperature control	

Detector

Block temperature	<input type="text"/> 100	°C
<input checked="" type="checkbox"/> Enable detector		
Filament temperature	<input type="text"/> 245	°C

Insert > Wait

Wait until baseline and temperatures are stable.

Insert > Start Recording

One measurement every 1.0 s

Insert > Temperature Ramp

- Sample ramp**
- End temperature: 400 °C
 - Ramp rate: 10 °C/min
 - Hold time: 30 min



The application automatically inserts a *Stop Recording* step when a *Start Recording* step is inserted. Ensure that the *Temperature Ramp* step is inserted within the *Start/Stop Record* loop.

- **Termination:** Double click *Termination* step in the experiment list box (or click *Termination*, then click **Edit**).

Temperature

Sample	Rate
<input type="text"/> °C	<input type="text"/> °C/min
<input checked="" type="checkbox"/> Return to ambient temperature	
<input type="checkbox"/> Disable temperature control	

Detector

Block temperature	<input type="text" value="100"/>	°C
<input type="checkbox"/> Enable detector		
Filament temperature	<input type="text" value="245"/>	°C

- f. Select the *Report Options* tab and modify the values as needed.
- g. Click **Save**, then click **Close**.
5. Start the analysis.
 - a. Go to **Unit > Sample Analysis**. From the *Files* list box, select the sample file created in the previous step. Edit the file as needed. Click **Next**.
 - b. From the drop-down list, select the calibrations associated with each experiment in the sample file (if any). For this example, select *None*. Click **Next**.



Calibration files can also be associated with a sample file after analysis using *Set Calibration in the Peak Editor*.

- c. Read the cautionary window and make any necessary changes.
- d. Click **Start** to start the analysis.

As the temperature increases, the copper oxide is reduced, the water produced by the reaction is collected in the trap (if used), and the amount of hydrogen consumed is detected and transmitted to the application. Use the *Results* view to display a chromatogram of the hydrogen consumed from the detector signal as a function of the ramping temperature.

A hydrogen consumption peak, which corresponds to the reduction capacity of copper oxide, is displayed. The maximum peak should occur at approximately 280 °C. This temperature varies highly, depending on the CuO particle size. Larger particle size shifts the temperature upward to 330 °C or more. Under certain combinations of sample, hydrogen concentration, and flow rate, two peaks may appear due to the transition state of Cu²⁺ to Cu⁺ to Cu.

12 DIAGNOSTICS

Unit [n] > Diagnostics

Use to display diagnostic readings, start diagnostic tests, and open saved diagnostic reports. Each test generates a file to the default directory name and path of ...\\...\\Service\\userdiag unless another directory name was specified. These reports can be sent to a Micromeritics Service Representative for examination.

SHOW ALL READINGS

Unit [n] > Diagnostics > Show All Readings

The *Show All Readings* window displays the calibrated readings of all sensors in the system.

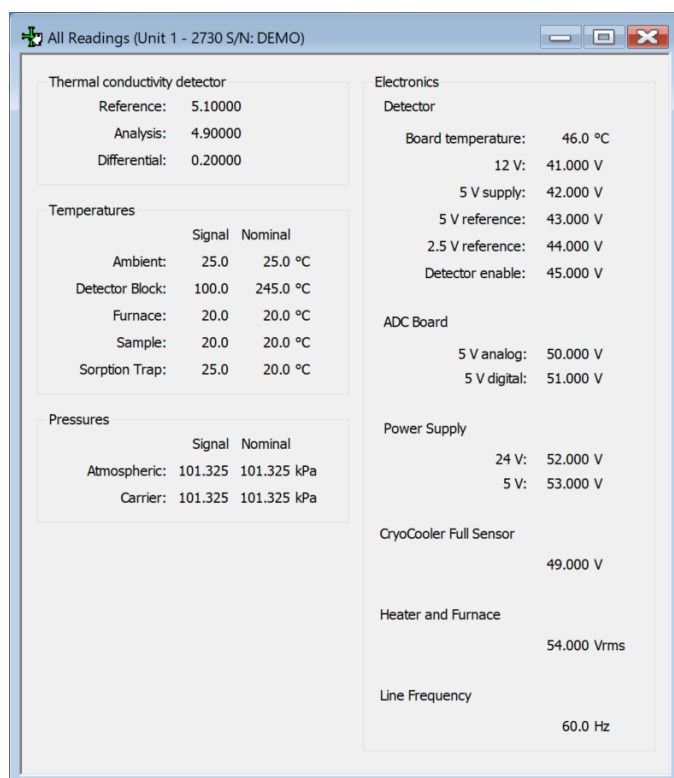

DIAGNOSTIC TEST REPORT

Displays previously run diagnostic service tests. Separate directories store tests run once, daily, weekly, and monthly. Diagnostic test report files have a .SVT file extension and are stored in the ...\\Service directory.

SAVE FILES FOR PROBLEM DIAGNOSIS

Unit [n] > Diagnostics > Save Files for Problem Diagnosis

Use to compress pertinent diagnostic information into a single zip file. This file can be sent to a Micromeritics Service Representative for problem resolution.

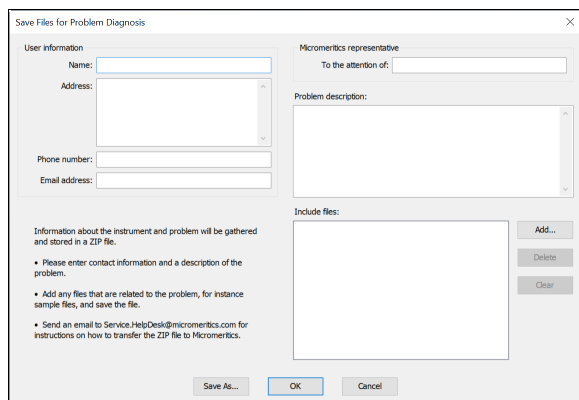

1. Complete the form. A default file named *Diagnostics-[date].zip* is created unless another file name is specified.
2. Add any files that are related to the problem — such as sample files — and save the file.
3. Send an email to Service.Helpdesk@MalvernPanalytical.com for instructions on how to transfer the .ZIP files to Micromeritics.

Save Files for Problem Diagnostics

Selections	Description
Problem description [text box]	Enter information that would be helpful to the Micromeritics representative.
Include Files [button]	<ul style="list-style-type: none"> ■ Add. Click to select additional files to send with this problem diagnosis. ■ Delete. Select the file in the <i>Include Files</i> box, then click Delete to remove the file from the list. ■ Clear. Click to clear all files from the <i>Include Files</i> box.
Save As [button]	Click to specify the name and location of the compressed file. Make a note of the file name and location. This file will need to be sent to your Micromeritics representative for problem resolution.
Micromeritics representative [text box]	Enter the name of your Micromeritics representative. This information will remain on the window each time files for problem diagnosis need to be submitted (can be modified as necessary).

Save Files for Problem Diagnostics (continued)

Selections	Description
User Information [text box]	Enter information for the person to be contacted by a Micromeritics representative. This information will remain on the window each time files for problem diagnosis need to be submitted (can be modified as necessary).
	For fields and buttons not listed in this table, see Common Fields and Buttons on page 2 - 5 .

**This page
intentionally
left blank**

13 CALIBRATION



A calibration file was created specifically for the analyzer and included with the accessories. It is not necessary to recalibrate the system unless it seems out of calibration.

Disabled calibration menu options can be accessed only with the assistance of an authorized Micromeritics Service Representative. Calibrations can be saved to a file and reloaded later.

Generally, it will not be necessary to change the data in the calibration file. However, if a condition occurs during the operational verification that requires changes to the calibration data, changes should be saved in a file. Calibration data files are retained in the analyzer history file and can be reloaded in the event that calibration data becomes corrupt.

GAS CONCENTRATION CALIBRATION

[Create Sample Files on page 3 - 2](#)

Use to calibrate the TCD so that peak area data can be converted to volume data. During a gas calibration, a series of known gas mixtures flows through the analyzer and the resultant signal readings are recorded. The analyzer can then use these data to calculate the concentrations of unknown mixtures flowing past the detector during subsequent analyses.

In some cases (such as in TPR analyses), the analyzer needs to know how to correlate the signal readings collected in the analysis with the volume of gas uptake at any given point in the analysis. If the analyzer is provided with a series of known gas concentrations, and it records the signal associated with each known concentration, then it can use this information to calculate the concentrations associated with the signals it recorded during the analysis. From that point, it can also calculate the volume of gas associated with each peak in the data.



Zeroing all Mass Flow Controllers is recommended prior to gas calibration to ensure its accuracy. Consider inserting a Zero MFCs task to the analysis conditions list. See [Experiment Steps, Zero Mass Flow Controllers](#).

1. Prepare and install a clean, empty sample tube.
2. Ensure the correct gases are connected and the *Adsorptive Properties* file has been updated.
3. Create the sample file:
 - a. Go to **File > New Sample**.
 - b. Complete the fields on the *Sample Description* tab, as needed.
4. Select the *Analysis Conditions* tab.
5. Click **Insert** and select *Gas Calibration*.
6. Click **OK**.

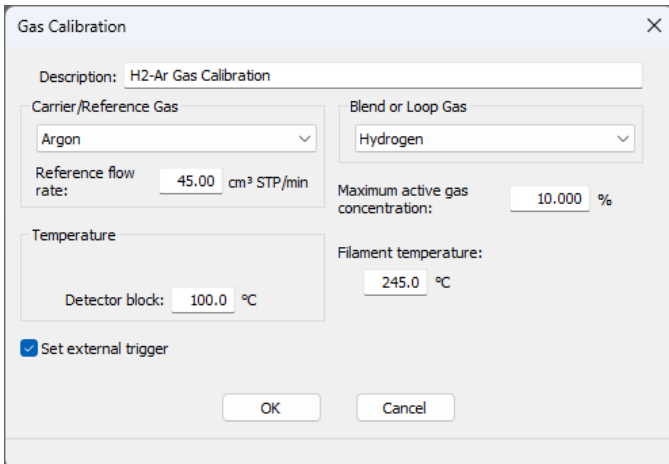

Gas Calibration

Description: H2-Ar Gas Calibration

Carrier/Reference Gas: Argon

Blend or Loop Gas: Hydrogen

Reference flow rate: 45.00 cm³ STP/min

Maximum active gas concentration: 10.000 %

Temperature: Detector block: 100.0 °C

Filament temperature: 245.0 °C

Set external trigger

OK Cancel

- Complete the window entering the appropriate information for the sample being used.



Specific selections and entries shown in this table are only applicable when using Micromeritics samples. Make the necessary adjustments when using non-Micromeritics samples.

Selections	Description
Blend or Loop Gas	Select <i>Hydrogen</i> and enter <i>10</i> for the <i>Maximum active gas concentration percentage</i> .
Carrier/Reference Gas	Select <i>Argon</i> and enter <i>45</i> for the <i>flow rate</i> .
Description	Enter a description for this calibration.
Detector Block	Enter the Detector Block temperature for this calibration. A typical setting is 100 °C.
Filament temperature	Enter the temperature between 20 to 250 °C for the filament. A typical setting is 245 °C.
Maximum active gas concentration	Enter the Maximum Active Gas Concentration percentage to use for blending.
Set external trigger	If selected, the contact closure used to trigger an external mass spectrometer will be activated. If deselected, the contact closure will be deselected.
Temperature	Enter a value between 20.0 and 150.0 °C for the <i>Detector block</i> . A typical setting is 100 °C for the block.

- Click **OK** again to close the Calibration window.
- Click **Save As**, provide a new file name, then click **Close**.
- Go to **Unit [n] > Sample Analysis**.
- Click **Browse** to locate sample file previously created.
- Click **Start** to start the analysis. Use the other views of the analysis window to observe the progress of the analysis. During the automatic analysis, the analyzer decreases the proportion of the active gas in 1% increments, beginning with 100% and ending with 0%. The resultant data should appear as a series of ten stepwise changes in the TCD signal.
- When the analysis ends, close the *Analysis* window.
- When the displayed sample temperature reaches the ambient temperature, open the furnace and remove the sample tube.
- Go to **Options > Signal Calibration > New**. Select the calibration file, then click **Open**.
- Click **Load Calibration Data** then select the sample file for this calibration, then click **OK**.
- Click **OK**. The data in the sample file are automatically inserted into the appropriate fields of the *Signal Calibration* window.

18. Assess the gas concentration plot, Goodness of Fit, and Coefficients to determine if the calibration file is acceptable. Use your laboratory's standards to determine what level of linearity is acceptable. As a general guideline, use a calibration file with a very low value for Goodness of Fit (less than 1/2% of the maximum concentration) when 1st or 2nd Degree is specified.

Data points that deviate significantly from linear can be deleted. Evaluate the results when the degree is changed (select a different degree from the drop-down list).

19. When satisfied with the calibration file, enter a descriptive name in the *Description* field.
20. Click **Save**, then click **Close**.
21. Go to **Options > Signal Calibration > Report** to select a report to generate.

LOOP CALIBRATION

[Create Sample Files on page 3 - 2](#)

Use to calibrate the gas injection loop's volume under current conditions so that precise volume injections can be made in analyses that perform loop injections, such as Pulse Chemisorption experiments. During a loop calibration, the operator repeatedly injects a known volume of gas through the analyzer septum using a syringe, then the analyzer repeatedly injects gas from the loop. This results in a series of recorded peaks in the TCD signal. After the operation completes, the operator can adjust the peaks in the peak editor and make a loop calibration report. This calculates the loop volume by comparing the average area of the manual injection peaks to the average area of the automatic injection peaks. The operator then enters the calculated loop volume under **Unit [n] > Unit Configuration** for use in subsequent analyses.

1. Install the correct injection loop.
2. Prepare and install a clean, empty sample tube.
3. Ensure the correct gases are connected.
4. Create the sample file:
 - a. Go to **File > New Sample**.
 - b. Complete the fields on the *Sample Description* tab, as needed.
5. Select the *Analysis Conditions* tab.
6. Click **Insert** and select *Loop Calibration*.
7. Click **OK**.

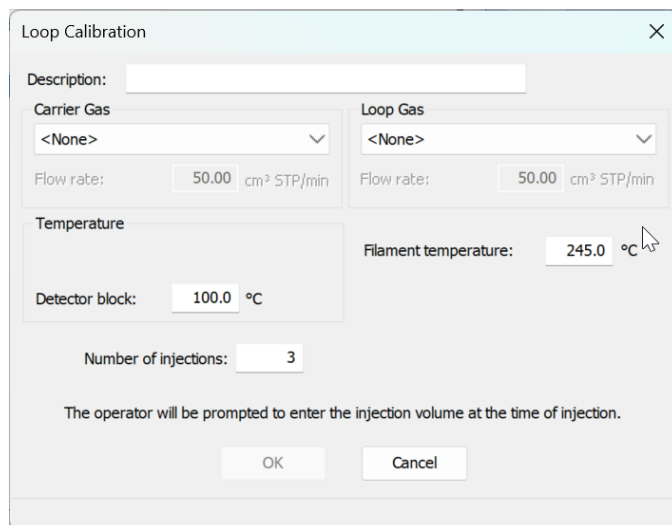

- Complete the dialog box entering the appropriate information for the sample being used.



Specific selections and entries shown in this table are only applicable when using Micromeritics samples. Make the necessary adjustments when using non-Micromeritics samples.

Selections	Description
Carrier Gas Flow Rate	Select <i>Helium</i> and enter <i>20</i> for the Flow Rate.
Description	Enter a description for this calibration.
Detector Block	Enter the temperature for this calibration. A typical temperate is 100 °C.
Filament temperature	Enter the temperature between 20 to 250 °C for the filament.
Loop Gas Flow Rate	Select <i>Argon</i> and enter <i>20</i> for the Flow Rate .
Number of injections	Enter the number of automatic injections (3-10) to be done with the loop during calibration.

- Click **OK** again to close the Calibration window.
- Click **Save As**, provide a new file name, then click **Close**.
- Go to **Unit [n] > Sample Analysis**.
- Click **Browse** to locate sample file previously created.
- Click **Start** to start the analysis. Use the other views of the analysis window to observe the progress of the analysis. During the first half of the analysis, the analyzer displays a prompt before each manual injection. Enter the syringe's physical injection volume (which should be 100% of the nominal loop volume), click **Continue**, then inject gas through the analyzer septum from the syringe. During the second half of the analysis, the analyzer automatically injects gas from the loop. The resultant data should appear as a series of peaks in the TCD signal.
- When the analysis ends, close the *Analysis* window.
- When the displayed sample temperature reaches the ambient temperature, open the furnace and remove the sample tube.



Use the cotton gloves provided in the accessory kit when handling heated surfaces. These cotton gloves are not intended to protect hands when heated surfaces are above 60 °C.

- Go to **File > Open > [.SMP]**. Open the .SMP file containing the calibration experiment. Verify the defined peaks are properly marked (or correct them) using the *Peak Editor*.
- On the *Reports* tab, select only the *Loop Calibration* report option. Click **Preview** to view the results, including the Loop Volume.
- Go to **Unit [n] > Unit Configuration**. In the *Loop Volume* field, enter the *Loop Volume*.

LOAD CALIBRATION FROM FILE

Use to load a previously saved calibration file.

It is recommended that the current calibration settings be saved using prior to loading another calibration file. When loading a previously saved calibration file, a backup of the current file is created and saved as *[SN]last.cal*. The backup file is overwritten each time a new one is created.



Changing the calibration may affect the analyzer's performance.

SAVE CALIBRATION TO FILE

Use to save the current calibration settings to a backup file which can later be reloaded using the menu option.

The default file naming convention for calibration files can be used or the file name can be changed. The default file name of 0217-2013-04-25.CAL is interpreted as:

0217	Analyzer serial number
2013-04-25	Date the calibration file was saved
.CAL	File name extension

**This page
intentionally
left blank**

A ADVANCED REPORTS - PYTHON MODULE

- **Summary reports.** Consist of summary sections, each containing a two-column table of label and value pairs. Summary reports are created with the *mic.summary* call.
- **Tabular reports.** Consist of one or more tables each containing one or more labeled columns of data. Tabular reports are created with the *mic.table* call.
- **Graphical reports.** Consist of a single graph with one or more curves on one or two y-axes. Graphical reports are created with the *mic.graph* call.

Calls for accessing the sample file data can be found in the *Mic Module Python Calls* section of this appendix. More advanced example python scripts are included in the analyzer software.

ADVANCED REPORTS

Up to five Advanced reports, each with up to 10 summary reports, 10 tabular reports, and 10 graphical reports can be created. To use this feature, a file containing a Python script that imports a "mic" Python module must be created. See [MicModule Python Calls on page A - 8](#) for an example of a Python script and functions for the "mic" Python module.

1. Create the Python script and save it in the *Scripts* directory.
2. Open a sample file with a *Complete* status.
3. Select *Advanced* in the view selector drop-down list at the bottom of the window to return to the tabbed view.
4. On the *Report Options* tab, select *Advanced* in the *Selected Reports* list box, then click **Edit**.
5. On the *Advanced Report Options* window, click **Add** in the *Available Scripts* group box to locate and select the Python script. Repeat for each script to be added.

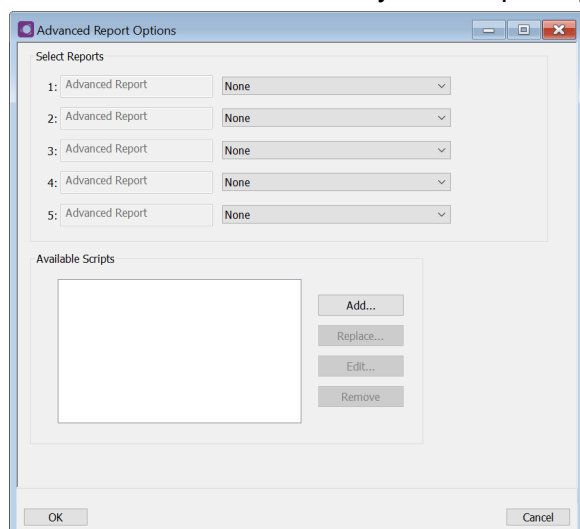

6. In the *Selected Reports* group box, click the drop-down arrows to select up to five Python scripts previously added in the *Available Scripts* box.
7. On the *Report Options* tab, click **Preview**. The Python Reports will be included on the tabs across the top portion of the *Reports* window.

Advanced Reports

Selections	Description
Advanced Report 1 through 5 [drop-down box]	Use the drop-down lists to select currently-defined functions used to define the report calculations and output.
Available Scripts [group box]	Lists the available reports and provides the option to add, replace, edit, or remove reports.
	For fields and buttons not listed in this table, see Common Fields and Buttons on page 2 - 5 .

SCRIPTS

Run a Script

1. Open a sample file with a *Complete* file status.
2. Select *Advanced* in the view selector drop-down list at the bottom of the window.
3. Select the *Report Options* tab.
4. Highlight *Advanced* in the *Selected Reports* list box, then click **Edit**.
5. On the *Advanced Report Options* window, click **Add**.
6. Select one or more python scripts then click **Select**. The selected scripts become a part of the drop-down list in the *Available Scripts* section of the *Advanced Report Options* window.
7. In the *Select Reports* section, select up to five *Advanced* reports in the drop-down lists.
8. Click **OK**.
9. Click **Preview** on the *Report Options* tab to view all reports selected in the previous window.

Remove a Script

Select the script in the *Available Scripts* box then click **Remove**. The script is removed from the application however, the original .py text file is not affected.

Edit a Script

Selections	Description
Add [button]	Adds one or more scripts to the <i>Available Scripts</i> box. The added scripts then become available as options in the <i>Selected Reports</i> section.
Edit [button]	Edits the script stored within the application but does not affect the original .py text file.
Remove [button]	Removes the script from the <i>Available Scripts</i> box but does not affect original .py text file.
Replace [button]	Replaces the contents of the selected script however, the script name remains the same.

PYTHON REPORTS

Graphic Report

This script is an example of the mic module producing a graph with two curves:

```
1 import mic
2 import numpy as np
3
4 mic.graph( 'My Graph', 'X', 'F(X)' )
5 myx = np.array( [0.1, 0.2, 0.3, 0.4, 0.5, 0.6, 0.7, 0.8, 0.9, 1.0 ]
6 )
7 mic.graph.add( 'X2', myx, myx*myx, marker='o' )
8 mic.graph.add( 'sin(X)', myx, np.sin(myx), marker='^' )
```

The results are:

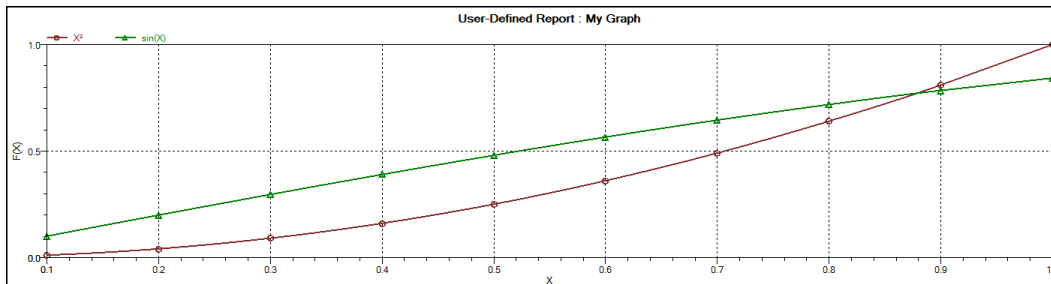

Summary Report

This script produces a summary report with two summaries:

```
1 import mic
2 import numpy as np
3
4 mic.summary( "My Summaries" )
5 mic.summary.add( "Summary A",
6                 ["Label 1:", "Label 2:", "Label 3:"],
7                 ["val1", "val2", "val3"] )
8 mic.summary.add( "Summary B",
9                 ["Label 4:", "Label 5:", "Label 6:"],
10                ["val4", "val5", "val6"] )
```

The result is:

Summary A

Label 1: val1
Label 2: val2
Label 3: val3

Summary B

Label 4: val4
Label 5: val5
Label 6: val6

Tabular Report

If more than one column is required, the call `mic.table` is employed. This script produces a tabular report consisting of two tables.



This script uses the Python package `numpy` and `c-style` formatting of the numerical values.

```
11 import mic
12 import numpy as np
13
14 mic.table( "My Tables" )
15 mic.table.addtable( "My Set A" )
16 mic.table.addcolumn( "X", ["1.0", "2.0", "3.0"] )
17 mic.table.addcolumn( "Y", ["0.5", "1.0", "1.5"] )
18 x1 = 0.2
19 x2 = 0.5
20 x3 = 3.14159/2
21 mic.table.addtable( "My Set B" )
22 mic.table.addcolumn( "X", [ '{:8.3f}'.format(x1),
23                             '{:8.3f}'.format(x2),
24                             '{:8.3f}'.format(x3)] )
25 mic.table.addcolumn( "sin(X)", [ '{:8.3f}'.format(np.sin(x1)),
26                                   '{:8.3f}'.format(np.sin(x2)),
27                                   '{:8.3f}'.format(np.sin(x3))] )
28 mic.table.addcolumn( "cos(X)", [ '{:8.3f}'.format(np.cos(x1)),
29                                   '{:8.3f}'.format(np.cos(x2)),
30                                   '{:8.3f}'.format(np.cos(x3))] )
```

The result is:

My Set A	
X	Y
1.0	0.5
2.0	1.0
3.0	1.5

My Set B		
X	sin(X)	cos(X)
0.200	0.199	0.980
0.500	0.479	0.878
1.571	1.000	0.000

MicMODULE PYTHON CALLS

[Get Experiment Information on the facing page](#)

[Get Imported Pore Data on page A - 12](#)

[Get Metal Composition for Chemisorption on page A - 13](#)

[Get Sample Information Item on page A - 11](#)

Get Experiment Information

```

1 mic.dyn_chem_experiment(exp_num, sec_num=0, item=''):
2
3     Get data associated with the indexed experiment
4
5     Keyword arguments:
6
7     exp_num    --- The index of the experiment to acquire
8                 information for. Indexing begins at 1
9
10    sec_num    --- If zero, the primary experiment data is
11                returned.
12                If greater than zero, returns associated sec-
13                ondary
14                experiment if any (typically these are mass
15                specs).
16
17    item        --- the specific experiment property to return
18                information on. If '' or None, then return
19                the whole experiment dictionary
20
21    Usage:
22
23    exp = mic.dyn_chem_experiment(exp_num = 1)
24    ms1 = mic.dyn_chem_experiment(exp_num = 1, sec_num = 1)
25    expid = mic.dyn_chem_experiment(exp_num = 1, item = 'id')
26    temp = mic.dyn_chem_experiment(exp_num = 1, item = 'tem-
27                perature')
28
29 mic.dyn_chem_experiment_all():
30
31     Return a dictionary of all experiments. The key is the experiment
32     number, the value is a dictionary with keys from 0 (primary exper-
```

```
iment  
29     data) through n where n is the number of secondary experiments  
    (e.g.,  
30     mass spec data).
```

Get Sample Information Item

```
1 mic.sample_information( item, sample_number = 0 ):
2
3 Keyword arguments:
4
5 item          --- string identifying the item to be returned.
6                For example; 'sample mass', or 'sample descrip-
7                tion'
8                The default is an empty string for which the
9                return value is a list of all available keywords
10
11 sample_number --- Sample to retrieve
12                0          : current sample file (default)
13                1 through 8 : corresponding overlay sample file
14
15 Usage:
16
17 all_keywords = sample_information()
18 mass        = sample_information('sample mass')
19 mass        = sample_information('sample mass',0)
```

Get Imported Pore Data

```
1 mic.imported_pore_data(import_number=1):
2
3 Get imported pore data.
4
5 Keyword arguments:
6
7     import_number --- the import number (1 through 8)
8
9 Usage:
10
11     porew, incvol, desc = mic.imported_pore_data(1)
12
13     porew --- array of pore dimension boundaries (angstroms);
14             empty-array if unavailable.
15     incvol --- array of incremental pore volumes (cm3/g);
16             empty-array if unavailable.
17     desc   --- Name of data set; empty-string if unavailable.
```

Get Metal Composition for Chemisorption

```

1 mic.metal_composition(metal='', metal_property='', sample_
  number=0):
2
3 Get information about the active metals in this sample
4
5 Keyword arguments:
6
7 metal          --- the metal to return information about
8                 if '' or None, then return a list of the
9                 active metals
10
11 metal_property --- the specific property to return information
  on
12                 if '' or None, then return all the prop-
13                 erties
14                 for the specified metal (requires metal to
15                 be
16                 specified)
17
18 sample_number --- Identifier for the metal data to retrieve
19                 0          : current sample file (default)
20                 1 through 8 : corresponding overlay sample
21                 file
22
23 Usage:
24
25 metal_list = mic.metal_composition()
26 copper_prop = mic.metal_composition('copper')
27 copper_perc = mic.metal_composition('copper',
                                     'percent of sample mass')
28
29 In the above first usage case, the list of active metals is
30 returned.
    
```

```
28 In the above second usage case, a python dictionary type
29 is returned which includes all the properties of the metal
30 available and their corresponding values. The last case returns
31 a single value (int, float, or string) for the specified property.
32
33 The metal_property keywords which one can use are
34
35     atomic weight
36     oxygen atoms
37     density
38     percent of sample mass
39     metal atoms
40     cross sectional area
41     percent reduced
42     stoichiometry GASNAME
43
44 where in the last keyword one substitutes the desired gas name to
45 obtain its stoichiometry factor. One can also make the call
46 metal_composition(metalname) without any metal_property keyword
47 provided to see the whole dictionary of keywords and values.
```

B ATOMIC WEIGHTS AND CROSS-SECTIONAL AREAS

Atomic Weights and Cross-sectional Areas for Selected Metals

Metal	Symbol	Atomic Weight (g/mol)	Cross-sectional Area (nm²)	Density (g/mL)
chromium	Cr	51.996	0.0635	7.19
cobalt	Co	58.933	0.0662	8.9
copper	Cu	63.54	0.0680	8.96
gold	Au	196.967	0.08696	18.9
hafnium	Hf	178.490	0.0862	13.3
iridium	Ir	192.220	0.0769	22.4
iron	Fe	55.847	0.0613	7.89
manganese	Mn	54.938	0.0714	7.43
molybdenum	Mo	95.940	0.0730	10.22
nickel	Ni	58.710	0.0649	8.9
niobium	Nb	92.906	0.0806	8.57
osmium	Os	190.220	0.0629	22.6
palladium	Pd	106.400	0.0787	12.02
platinum	Pt	195.090	0.0800	21.45
rhenium	Re	186.2	0.0649	21.02
rhodium	Rh	102.905	0.0752	12.1
ruthenium	Ru	101.070	0.0613	12.4
silver	Ag	107.868	0.0869	10.5
tantalum	Ta	180.947	0.0800	16.6
thorium	Th	232.038	0.1350	11.7
tin	Sn	118.710	0.1082	4.54
tungsten	W	183.850	0.0741	19.3
vanadium	V	50.942	0.0680	6.11
zirconium	Zr	91.220	0.0877	6.51

**This page
intentionally
left blank**

C GAS CHARTS

RELATIVE THERMAL CONDUCTIVITY OF GASES

Name	Chemical Formula	Conductivity (Relative to Air)
Air		1.00
Ammonia	NH ₃	0.92
Argon	Ar	0.68
Butane	C ₄ H ₁₀	0.60
Carbon Dioxide	CO ₂	0.62
Carbon Monoxide	CO	0.97
Ethane	C ₂ H ₆	0.79
Helium	He	5.84
Hydrogen	H ₂	7.07
Krypton	Kr	0.37
Methane	CH ₄	1.29
Neon	Ne	1.87
Nitric Oxide	NO	0.99
Nitrogen	N ₂	1.00
Nitrogen Dioxide	NO ₂ or N ₂ O ₄	1.51
Nitrous Oxide	N ₂ O	0.65
Oxygen	O ₂	1.02
Sulfur Dioxide	SO ₂	0.38
Water Vapor	H ₂ O	0.67

TYPICAL GASES USED

Flow Rate of 50 cm ³ /min				
Test	Preparation Gas	Carrier Gas	Loop Gas	Other
TPR Experiment	Argon	10% H ₂ in Argon	N/A	
Calibration	N/A		Argon	TCD Level Calibration
TPD Ammonia	Helium or 10% NH ₃ in Helium	Helium	N/A	
Calibration	N/A		NH ₃ in Helium	TCD Level Calibration
TPD Hydrogen	10% H ₂ in Argon	Argon	N/A	Calibration
Calibration	N/A		10% H ₂ in Argon	TCD Level Calibration
TPD Oxygen	10% O ₂ in Helium	Helium	N/A	
Calibration	N/A		10% O ₂ in Helium	TCD Level Calibration
TPO Experiment	Helium	10% O ₂ in Helium	N/A	
Calibration	N/A		Helium	TCD Level Calibration
H₂ Pulse Chemisorption	10% H ₂ in Argon	Argon	10% H ₂ in Argon	
CO Pulse Chemisorption		Helium	10% CO in Helium	
Calibration	Not Required			
BET Surface Area	Helium	30% N ₂ in Helium	N/A	
Calibration	N/A			User-defined manual injections of N ₂ (0.5, 1.0, 1.5, and 2.0 cm ³)

GAS CONVERSION CONSTANTS

Dynamic analysis uses a Mass Flow Controller (MFC) to control the flow of gases. The MFC requires a conversion constant for each gas or gas mixture to compensate for variations in gas flows resulting from variations in the properties of gases. A default gas table containing MFC conversion constants is included on the *Options* menu. The following table provides a more complete list of gases and their conversion constants.

Gas Conversion Constants for the MFC

Gas	Symbol	MFC Conversion Constant (H ₂ = 1.000)
Acetylene	C ₂ H ₂	0.6535
Air (mixture)		0.9901
Allene	C ₃ H ₄	0.4752
Ammonia	NH ₃	0.7822
Argon	Ar	1.3861
Arsine	AsH ₃	0.7525
Boron Trichloride	BCl ₃	0.4356
Boron Trifluoride	BF ₃	0.5743
Bromine Pentafluoride	BrF ₅	0.2871
Bromine Trifluoride	BrF ₃	0.4356
Butane	C ₄ H ₁₀	0.2871
Butene	C ₄ H ₈	0.3267
Carbon Dioxide	CO ₂	0.7723
Carbon Monoxide	CO	0.9802
Carbon Tetrachloride	CCl ₄	0.3465
Carbon Tetrafluoride	CF ₄	0.4752
Carbonyl Fluoride	COF ₂	0.2673
Carbonyl Sulfide	COS	0.6733
Chlorine	Cl ₂	0.8218
Chloroform	CHCl ₃	0.4356
Chlorine Trifluoride	ClF ₃	0.4257

Gas Conversion Constants for the MFC (continued)

Gas	Symbol	MFC Conversion Constant (H ₂ = 1.000)
Cyanogen	C ₂ N ₂	0.4950
Cyclopropane	C ₃ H ₆	0.5050
Deuterium	D ₂	0.9901
Diborane	B ₂ H ₆	0.5446
Dichlorosilane	SiH ₂ Cl ₂	0.4356
Dimethylamine	(CH ₃) ₂ NH	0.6634
Dimethylether	(CH ₃) ₂ O	0.5842
Ethane	C ₂ H ₆	0.5446
Ethyl Chloride	C ₂ H ₅ Cl	0.2871
Ethylene	C ₂ H ₄	0.6139
Ethylene Oxide	C ₂ H ₄ O	0.5842
Fluorine	F ₂	0.9208
Fluroform	CHF ₃	0.5644
Freon 11	CCl ₃ F	0.3762
Freon 12	CCl ₃ F ₂	0.3861
Freon 13	CClF ₃	0.4257
Freon 13 B1	CBrF ₃	0.4059
Freon 14	CF ₄	0.4703
Freon 21	CHCl ₂ F	0.4554
Freon 22	CHClF ₂	0.5050
Freon 23	CHF ₃	0.5644
Freon 113	CCl ₂ F-CClF ₂	0.2277
Freon 114	CCl ₂ F ₄ -CClF ₂	0.2554
Freon 115	CClF ₂ -CF ₃	0.2713

Gas Conversion Constants for the MFC (continued)

Gas	Symbol	MFC Conversion Constant (H ₂ = 1.000)
Freon 116	CF ₃ -CF ₃	0.2277
Germane	GeH ₄	0.6436
Helium	He	1.3762
Hexamethyldisizane	HMDS	0.1386
Hydrogen	H ₂	1.0000
Hydrogen Bromide	HBr	0.9703
Hydrogen Chloride (Dry)	HCl	0.9802
Hydrogen Fluoride	HF	0.9901
Hydrogen Iodide	HI	0.9505
Hydrogen Selenide	H ₂ Se	0.8317
Hydrogen Sulfide	H ₂ S	0.8416
Isobutane	C ₄ H ₁₀	0.3069
Isobutylene	C ₄ H ₈	0.3366
Krypton	Kr	1.3762
Methane	CH ₄	0.8020
Methylamine	CH ₃ NH ₂	0.5644
Methyl Bromide	CH ₃ Br	0.6436
Methyl Chloride	CH ₃ Cl	0.6832
Methyl Fluoride	CH ₃ F	0.7525
Methyl Mercaptan	CH ₄ S	0.5842
Neon	Ne	1.3861
Nitric Oxide	NO	0.9901
Nitrogen	N ₂	0.9950
Nitrogen Dioxide	NO ₂	0.7525

Gas Conversion Constants for the MFC (continued)

Gas	Symbol	MFC Conversion Constant (H ₂ = 1.000)
Nitrogen Trioxide	N ₂ O ₃	0.4356
Nitrogen Trifluoride	NF ₃	0.5446
Nitrous Oxide	N ₂ O	0.7426
Oxygen	O ₂	0.9802
Ozone	O ₃	0.7327
Pentaborane	B ₅ Hg	0.2871
n Pentane	C ₅ H ₁₂	0.2376
Perchloryl Fluoride	ClO ₃ F	0.4455
Phosgene	COCl ₂	0.5050
Phosphine	PH ₃	0.7822
Phosphorous Pentafluoride	PF ₅	0.3465
Propane	C ₃ H ₈	0.3861
Propylene (Propene)	C ₃ H ₆	0.4653
Silane	SiH ₄	0.6733
Silicon Tetrachloride	SiCl ₄	0.3168
Silicon Tetrafluoride	SiF ₄	0.3960
Sulfur Dioxide	SO ₂	0.7228
Sulfur Hexafluoride	SF ₆	0.2970
Trichlorosilane	Cl ₃ HSi	0.3267
Trimethylamine	(CH ₃) ₃ N	0.3168
Tungsten Hexafluoride	WF ₆	0.2871
Uranium Hexafluoride	UF ₆	0.2178
Vinyl Bromide	C ₂ H ₃ Br	0.5248
Vinyl Chloride	C ₂ H ₃ Cl	0.5347
Vinyl Fluoride	C ₂ H ₃ F	0.5743

Gas Conversion Constants for the MFC (continued)

Gas	Symbol	MFC Conversion Constant (H₂ = 1.000)
Xenon	Xe	1.3762

**This page
intentionally
left blank**

D PEAK DETECTION / INTEGRATION OPTIONS



This section applies only to dynamic analysis samples.

File Open > [.RPO file] > [Integration button]

Or, select the **Integration** button while in the Peak Editor.

Peak detection parameters can be customized using the **Integration** button on the *Report Options* window or the **Integration** button on the Peak Editor window. Peak detection options can be customized while creating the sample file or after analysis. For Loop calibrations, peaks are found using events that occurred during the analysis — such as the time an injection started — instead of peak detection options.

Peak Detection/Integration Options

Selection	Description
Standard Settings [group box]	<ul style="list-style-type: none"> <li data-bbox="516 890 1438 1297"> <p>■ Baseline mode</p> <p>The Baseline Mode affects how the <i>Find All Peaks</i> function works.</p> <p>If <i>Best Fit Baseline</i> is selected, the bottom of the peaks is placed in the baseline that best describes the signal outside the range of the peaks. This assumes a linear baseline between the beginning and the end of the peak.</p> <p>If <i>Snap to Signal</i> is selected, the bottom of the peaks is moved to the signal recorded, not the best fit baseline between the peaks.</p> <li data-bbox="516 1318 1438 1516"> <p>■ Minimum peak height</p> <p>Sets the minimum height for peaks to be identified and included in the peak table. This value is expressed in terms of the trace's Y-axis units. Use a value of 0 (zero) to include all peaks.</p> <li data-bbox="516 1537 1438 1797"> <p>■ Peak smoothing</p> <p>Smoothing allows the application to average the points before using them, so that noise spikes are ignored. Specify the number of points to average into a single value during the peak picking process.</p> <p>The smoothing parameter can be turned off by setting the value at 1</p>

Peak Detection/Integration Options (continued)

Selection	Description
	<p>or 0 (zero). A setting of 1 disables smoothing, and the peak edges are interpolated to the best X-axis value. A setting of 0 also disables smoothing, but the peak edges (the points where the peak begins and ends) are not interpolated. Instead, the nearest data point is used as the peak edge.</p>
<p>Advanced Settings [group box]</p>	<ul style="list-style-type: none"> <p>■ Sensitivity</p> <p>Sensitivity sets the noise rejection level for identifying the peaks in a trace. Use a value from -100 to 100%. For example, a sensitivity level of 5% means that 5% of all local maxima in the trace are greater than the noise and are, therefore to be considered as peaks. A value of 100% identifies all local maxima (or minima for traces with transmission Y units) as peaks. One possible exception to note is the combination of other rejection parameters (such as <i>Minimum Peak Area and Minimum Peak Height</i>) which can reject peaks even when the sensitivity is set to 100%.</p> <p>The sensitivity can also be set to negative values to define a specific noise level (in Y units) for peak rejection. For example, a sensitivity setting of - 2.5% sets the noise rejection to 2.5 V. This means that maxima with an</p> <p>amplitude of 2.5 V or less will be considered as baseline noise instead of as peaks. (As opposed to the <i>Minimum Peak Height</i> rejection parameter which eliminates refined peaks by using their height above the baseline.)</p> <p>A setting of 0 (zero) automatically sets a default noise level for the trace.</p> <p>■ Maximum shoulder ratio</p> <p>There can also be shoulder peaks (also called combination peaks) within a group. See Maximum group separation. on page D - 4 for a description of peak groups. Shoulders are usually small peaks that are overlapped on the front or the tail of a larger peak. These peaks can also be called leaders and followers, respectively. As with baseline groups, the areas of these peaks can be calculated incorrectly. If the larger parent peak has a long tail with a much smaller peak riding on it, most of the area under the trace belongs to the parent peak. However, if the area of these peaks was determined</p>

Peak Detection/Integration Options (continued)

Selection	Description
	<p>using baseline grouping, the smaller peak would be calculated by using vertical drop lines at the edges. This would give the parent peak too little area, and the rider peak too much.</p> <p>The application can detect these shoulder peaks. The areas of shoulder peaks are calculated by drawing a skimmed baseline from the leading edge to the trailing edge. Either an exponential or a straight skim line can be used. The skim type is specified by a secondary method parameter and the default is exponential skimming. The remaining area between the shoulder peak baseline and the group baseline is considered to be part of the parent peak.</p> <p>The <i>Max Shoulder Ratio</i> parameter is used to specify whether the peaks that are overlapped in the front or the tail of much larger peaks should be identified as shoulder peaks. To use shoulder peak detection, use a nonzero value for the <i>Max Shoulder Ratio</i> parameter. After a baseline group has been identified, the application looks for peaks within the group that satisfy the following shoulder peak criteria:</p> <p>Shoulders must have a significantly higher Y value at one edge than the other. More importantly, the height of the shoulder above the common value must be much smaller than the height of the “parent” (larger) peak above the same valley. It must be smaller by the Max Shoulder Ratio setting. For example, a setting of 33 implies that shoulders must be smaller than 33% of their parents in terms of height above the common valley. The areas for shoulder peaks are calculated by drawing a skimmed baseline from the left shoulder peak baseline and the group common baseline is considered to be part of the parent peak.</p> <p>Shoulder peaks can only be calculated within a group of peaks. See Maximum group separation. on the next page for a description of peak groups. If the <i>Max Group Separation</i> parameter is set to 0 (no groups), a <i>Max Shoulder Ratio</i> parameter value is not used. Use a value of zero to specify no shoulder peak detection.</p> <p>A value of 33% works well with most data. Use a setting of zero to treat shoulder peaks with a perpendicular drop to the common group baseline instead of a skimmed baseline.</p> <p>If the application detects unwanted baseline noise peaks, try increasing the <i>Sensitivity</i> setting. Conversely, if some peaks are not</p>

Peak Detection/Integration Options (continued)

Selection	Description
	<p>detected, decrease the value.</p> <p>Maximum group separation.</p> <p>The application normally calculates peak areas by drawing a valley-to-valley baseline from the leading edge to the trailing edge of every identified peak. However, in many traces, the valleys between peaks do not always drop back to the original baseline. If a valley-to-valley baseline is used for this type of peak, the calculated area does not accurately reflect the true area under the peak.</p> <p>The application provides a parameter that allows the calculation of <i>Baseline Groups</i>. A group of peaks is defined by a common baseline that extends from the leading edge of the first peak in the group to the trailing edge of the last. The areas of grouped peaks are calculated by dropping vertical lines from the peak edges down to the group baseline.</p> <hr/> <div style="display: flex; align-items: center;">  <p>There may also be <i>Report Groups</i> defined by the method and assigned group letters from A through Z. Unlike these <i>Baseline Groups</i>, the <i>Report Groups</i> need not be next to one another. The two types of groups are not related.</p> </div> <hr/> <p>The <i>Max Group Separation</i> parameter is used to determine which peaks in a trace have a common baseline. When using peak grouping, the application compares the width (actually double the largest half width) of every identified peak in a trace to the width of the following peak. The <i>Max Group Separation</i> parameter specifies a percentage of the smallest of these two widths in X units. If the edges of two adjacent peaks differ by less than this value, the two peaks constitute a group and are given a common baseline. For example, if two adjacent peaks in the trace have largest half widths of 1 and 1.5 respectively, and the <i>Max Group Separation</i> parameter is set at 20%, then a difference of less than 0.4 X units between the adjacent edges of these peaks would make them a group with a common baseline. If the same two peaks have adjacent edges that are greater than 0.4 X units apart, they do not define a group, and each peak has its own separate baseline.</p> <p>The areas for grouped peaks are calculated by drawing imaginary vertical lines from the peak edges to the common baseline. Any</p>

Peak Detection/Integration Options (continued)

Selection	Description
	<p>peaks that share common edges are automatically considered a group and are given a common baseline for any <i>Max Group Separation</i> setting greater than 0. To specify no peak grouping (each identified peak has its own baseline), use a setting of 0. A value of 33% for this parameter works well with most data. Use a setting of zero to force all baselines to be drawn from peak valley to valley.</p> <ul style="list-style-type: none"> ■ Minimum peak area <p>This parameter sets the minimum area required for refined, processed peaks to be recognized, identified, and included in the peak table. Any peak with a calculated peak area smaller than the current setting is not detected. Values for this parameter are expressed in terms of the trace X-axis units multiplied by the Y-axis units (e.g., millivolt-minutes).</p> <p>Setting the Sensitivity parameter to large values (greater than 20%) can cause noise spikes (or dips) on the sides of major peaks to be identified as peaks themselves. If the areas of the peaks are smaller than the Minimum Peak Area parameter, major peaks in the trace may not be identified at all. Exercise caution when using high Sensitivity settings with the Minimum Peak Area parameter.</p> <p>If peaks are not detected by the application, lower the setting with a smaller value. This parameter must be adjusted in conjunction with the Peak Sensitivity and/or Minimum Peak Height parameters above. Peak rejection is accomplished through a combination of peak height and peak area rejection parameters. If the application is not detecting the peak(s) of interest, decrease both parameters.</p>
	<p>For fields and buttons not listed in this table, see Common Fields and Buttons on page 2 - 5.</p>

**This page
intentionally
left blank**

E TEMPERATURE PROGRAMMED ANALYSES

Most temperature-programmed experiments are based on the following highly simplified steps:

1. Gas flows into the analyzer.
2. The gas interacts with the sample as the temperature changes.
3. Gas flows past the detector.
4. The detector collects data.
5. The application plots and calculates results.

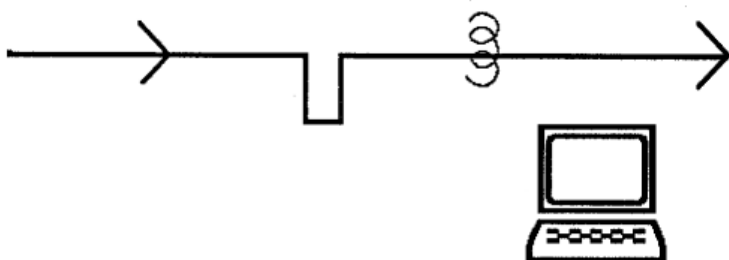

How the Detector Works

The detector contains heated filaments that measure the difference in gas thermal conductivity sensed between the gases flowing over the sample and reference filaments.

The gases flowing past the detector cool the filament by extracting heat. How quickly any type of gas removes heat from the detector is determined by its thermal conductivity¹⁾. A gas with a high thermal conductivity cools the filament rapidly, and more power is required to maintain its temperature. A gas with a lower thermal conductivity removes heat from the filament more slowly.

When the sample reacts with the gas, it causes changes in the composition of the gas and, consequently, changes the thermal conductivity of the gas. These changes are sensed by the detector as an increase or decrease in the amount of power required to maintain the filament at a constant temperature.

Data that are Collected

The detector reports the amount of electricity (in volts) required to keep its temperature constant during the analysis.

1) The thermal conductivity of a gas is its ability to conduct heat. Each gas has a distinct thermal conductivity.

The Role of the Sample Temperature

Because the sample's temperature determines how rapidly it interacts with the analysis gas (or if it reacts at all), data are collected over the range of temperatures specified.

In some experiments, you may prefer to start collecting data at a very low temperature to establish a baseline where the gas is completely unaffected by the sample. In other cases, you may prefer to collect data after a reaction has begun. In still other experiments, your primary interest may be determining the temperature at which the maximum reaction occurs.

For example, consider the example of a Temperature-Programmed Reduction (TPR). During the TPR, a metal oxide is reacted with hydrogen to form a pure metal. This reaction is referred to as "reducing" the metal; for example, TPR of a catalyst containing Platinum. Argon, which has a very low thermal conductivity, is used as a carrier gas. It is blended in a fixed proportion with hydrogen, an analysis gas with a much higher thermal conductivity. Then the gas mixture flows through the analyzer, through the sample, and past the detector.

When the gas blend begins flowing over the sample, a baseline reading is established by the detector. This baseline is established at a low enough temperature that no reduction of the sample is occurring, so the baseline level recorded by the detector is that of the thermal conductivity of the two gases in their fixed proportion. In other words, the proportion of gases flowing over the detector is the same as the proportion of gases entering the analyzer, because at the low temperature, there is no interaction with the sample.

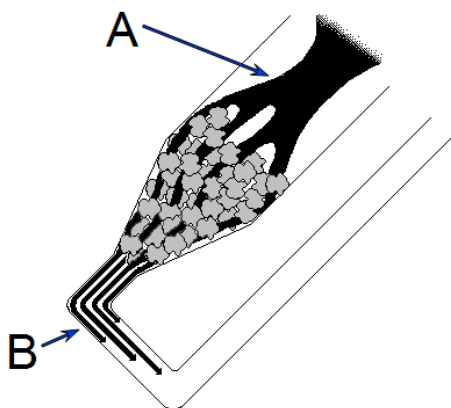

- A. Gas flows into the sample tube and through the sample.
- B. Before the reaction begins, the concentration of gases exiting the sample tube is unchanged after flowing through the sample.

The temperature is then changed, and when a critical temperature is reached, hydrogen atoms in the gas flow react with the sample, forming H_2O molecules. The H_2O molecules are removed from the gas stream using a cold trap. As a result, the amount of hydrogen in the argon / hydrogen gas blend inside the analyzer decreases, and the proportion between the two gases shifts in the direction of argon, as does the mixture's thermal conductivity.

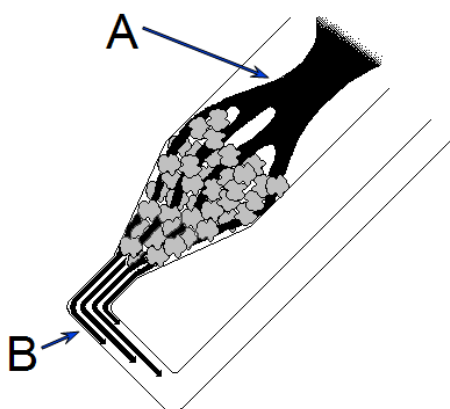

- A. As the temperature changes, the sample begins to react with the gas(es) flowing through it.
- B. The concentration of gases exiting the sample tube is altered after passing through the sample. This change in the gas concentration is recorded by the Thermal Conductivity Detector downstream.

Since argon has a lower thermal conductivity than hydrogen, the mixture's thermal conductivity consequently decreases. The flowing gas removes heat from the filament more slowly, requiring less electricity to maintain a constant filament temperature. The analyzer records the electrical demand as it changes (this is called the detector signal). The detector signal is recorded continuously over a range of temperatures. When these readings are graphed, the data form one or more peaks. Peaks can be positive or negative; negative peaks are shown in this example.

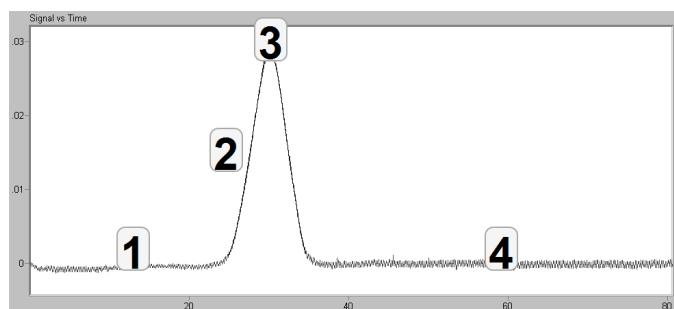

Negative Peaks Legend

Item	Description
1	Baseline readings. The gas(es) is (are) not reacting with the sample, so there is no change in the signal from reading to reading.
2	As the temperature changes, the sample begins to react with one of the gases. Therefore the gas mix is then made up of a larger proportion of the other gas. This causes a shift in the mixture's thermal conductivity. The detector measures this change by recording the change in the amount of electricity required to maintain constant filament temperature.
3	As temperature continues to increase, the interaction reaches a maximum, then begins to diminish.
4	As fewer and fewer sample atoms are available to bond with the analysis gas, there is less and less change in the mix of gases flowing into the analyzer and past the detector, so the thermal conductivity shifts back toward the baseline value.

This example illustrates the fundamental concept upon which the analyzer operates. Of course, the various types of analyses the analyzer can perform result in different types of traces. For example, a pulse chemisorption analysis results in a series of peaks that gradually increases in size as the sample is dosed with separate increments of gas. Initially, the gas uptake by the sample results in smaller peaks. But when all the active sites are saturated, no more gas can be taken up and the peaks become equal.

PEAK AREA

The area beneath each peak is calculated to provide information about the volume of gas reacted during the analysis. The *Calculations* document can be found on the Micromeritics web page (www.micromeritics.com).

AUTOMATIC OPERATION

The analyzer application provides a simple format to specify all the analysis conditions for the experiment; create a sample file which contains sample information and a list of specific steps the analyzer will follow to perform the experiment(s). Then, the analyzer automatically performs the analysis, from controlling the gas mixture and flow rate to monitoring the temperature and pressure. After analysis, use the Peak Editor to adjust the peaks to create reports that contain the data needed, without baseline noise or other undesirable effects.

Because up to 99 experiments can be specified and each experiment can contain up to 99 steps, the analyzer can perform a wide variety of preparation and analysis functions automatically.

INJECTION LOOP

Injection loops are provided for injecting carefully measured doses of gases for analyses such as Pulse chemisorption. The analyzer is shipped with a 0.5 cm³ loop installed. A 1 mL loop is also available. If the sample file is set so that a loop is used for introducing gas into the analyzer, the analyzer will automatically dose the sample as specified in the sample file.

SAMPLE PREPARATION AND CALIBRATION

Depending on the type of experiment(s) to be performed, sample preparation and/or calibration may be required. Specific instructions are contained in the appropriate sections of this manual.

A sample is prepared for analysis by removing unwanted adsorbates from the surface of the sample. This is usually accomplished by flowing gas over the sample and may include heating the sample. The flowing gas may be inert or chemically active gases may be used to activate the surface.

Calibration routines provide the analyzer and application with the appropriate information to convert electrical signals to physically meaningful data such as volume adsorbed, loop volume, and gas concentration.

**This page
intentionally
left blank**

F WORKSHEETS

Worksheets in this section may be copied as needed.

[*Gas Connections Worksheet on the next page*](#)

[*Manual Injections Worksheet on page F - 3*](#)

[*Sample Data Worksheet on page F - 4*](#)

GAS CONNECTIONS WORKSHEET

Use this form to record the connected gases. Use this form as a checklist against the gases identified in the analyzer application.

Unit number (S/N): _____

Date: _____

Operator: _____

Carrier Gas	Loop Gas

MANUAL INJECTIONS WORKSHEET

Use this worksheet to list the planned injection volumes, then check indicate if completed.

Injection	Comments/Volume	Completed
1		<input type="checkbox"/>
2		<input type="checkbox"/>
3		<input type="checkbox"/>
4		<input type="checkbox"/>
5		<input type="checkbox"/>
6		<input type="checkbox"/>
7		<input type="checkbox"/>
8		<input type="checkbox"/>
9		<input type="checkbox"/>
10		<input type="checkbox"/>
11		<input type="checkbox"/>
12		<input type="checkbox"/>
13		<input type="checkbox"/>
14		<input type="checkbox"/>
15		<input type="checkbox"/>
16		<input type="checkbox"/>
17		<input type="checkbox"/>
18		<input type="checkbox"/>
19		<input type="checkbox"/>
20		<input type="checkbox"/>

G EXPORTED DATA EXAMPLE

A PDF of an exported data example follows this topic. It references both AutoChem III and ChemiSorb Auto.

Serial # 0001 Unit 1 Port 1

Sample: CuO - Lot# 13CuO-02

Operator: PV

Submitter:

File: C:\Products Folder\ChemiSorb Auto 2730\Specific Sections\13CuO_Run6_Coil Trap.SMP

Started: 8/19/2025 4:56:02 PM

Completed: 8/19/2025 6:14:42 PM

Instrument: 2730

Sample mass: 0.1213 g

Report time: 10/9/2025 12:48:09 PM

Comments: Hold time 30 minutes.

Summary Report

Experiment 1: TPR

Analysis type: Temperature Programmed

Calibration: (AutoChem_III_0001) Pure H2-Ar Gas Cal 5/28/25

Measured flow rate: 45.00 cm³ STP/min

Signal offset: 0.00000

Signal inverted: No

Peak Number	Temperature at Maximum (°C)	Quantity (cm ³ /g STP)	Peak Active Gas Flow Rate (cm ³ STP/min)
1	200.6	30.03567	1.37755

Serial # 0001 Unit 1 Port 1

Sample: CuO - Lot# 13CuO-02

Operator: PV

Submitter:

File: C:\Products Folder\ChemiSorb Auto 2730\Specific Sections\13CuO_Run6_Coil Trap.SMP

Started: 8/19/2025 4:56:02 PM

Sample mass: 0.1213 g

Completed: 8/19/2025 6:14:42 PM

Report time: 10/9/2025 12:48:09 PM

Instrument: 2730

Comments: Hold time 30 minutes.

BET Single Point Tabular Report

BET Surface Area

4615- No experiments were selected for inclusion in this report.

4619- TCD calibration is required for the calculations of this report.

Serial # 0001 Unit 1 Port 1

Sample: CuO - Lot# 13CuO-02

Operator: PV

Submitter:

File: C:\Products Folder\ChemiSorb Auto 2730\Specific Sections\13CuO_Run6_Coil Trap.SMP

Started: 8/19/2025 4:56:02 PM

Completed: 8/19/2025 6:14:42 PM

Instrument: 2730

Sample mass: 0.1213 g

Report time: 10/9/2025 12:48:09 PM

Comments: Hold time 30 minutes.

Pulse Chemisorption Report

Pulse Chemisorption

4615- No experiments were selected for inclusion in this report.

Serial # 0001 Unit 1 Port 1

Sample: CuO - Lot# 13CuO-02

Operator: PV

Submitter:

File: C:\Products Folder\ChemiSorb Auto 2730\Specific Sections\13CuO_Run6_Coil Trap.SMP

Started: 8/19/2025 4:56:02 PM

Sample mass: 0.1213 g

Completed: 8/19/2025 6:14:42 PM

Report time: 10/9/2025 12:48:09 PM

Instrument: 2730

Comments: Hold time 30 minutes.

Loop Calibration Report

Loop Calibration

4615- No experiments were selected for inclusion in this report.

Serial # 0001 Unit 1 Port 1

Sample: CuO - Lot# 13CuO-02

Operator: PV

Submitter:

File: C:\Products Folder\ChemiSorb Auto 2730\Specific Sections\13CuO_Run6_Coil Trap.SMP

Started: 8/19/2025 4:56:02 PM
Completed: 8/19/2025 6:14:42 PM
Instrument: 2730

Sample mass: 0.1213 g
Report time: 10/9/2025 12:48:09 PM

Comments: Hold time 30 minutes.

Active Surface Area Report

Experiment 1 TPR

Analysis type: Temperature Programmed Desorption

Calibration: (AutoChem_III_0001) Pure H₂-Ar Gas Cal 5/28/25Measured flow rate: 45.00 cm³ STP/min

Signal offset: 0.00000

Signal inverted: No

Peak Table

Peak Number	Temperature at Maximum (°C)	Quantity Adsorbed (cm ³ /g STP)	Cumulative Quantity (cm ³ /g STP)
1	200.6	30.03567	30.03567

4625- No active metal with a percent of sample mass greater than zero was found.

Active Surface Area Analysis Summary

4625- No active metal with a percent of sample mass greater than zero was found.

Serial # 0001 Unit 1 Port 1

Sample: CuO - Lot# 13CuO-02

Operator: PV

Submitter:

File: C:\Products Folder\ChemiSorb Auto 2730\Specific Sections\13CuO_Run6_Coil Trap.SMP

Started: 8/19/2025 4:56:02 PM

Completed: 8/19/2025 6:14:42 PM

Instrument: 2730

Sample mass: 0.1213 g

Report time: 10/9/2025 12:48:09 PM

Comments: Hold time 30 minutes.

Sample Information

Method: Default
 Sample: CuO - Lot# 13CuO-02
 Operator: PV
 Submitter:
 Mass type: Calculated
 Empty tube: 26.1753 g
 Sample + tube: 26.2966 g
 Sample mass: 0.1213 g
 Density: 1.000 g/cm³
 Type of data: Automatically collected
 Instrument type: 2930
 Original instrument type: 2930
 Comments: Hold time 30 minutes.

Analysis Conditions

Analysis conditions: Analysis Conditions

View conditions for: Chemisorb Auto

Baseline Options

Stable Baseline

Slope threshold: 0.010 %/min

Duration: 5.00 min

Change from Baseline

 Acceleration threshold: 0.200 %/min²

Duration: 0.10 min

Return to Baseline

 Acceleration threshold: 0.050 %/min²

Duration: 1.00 min

Tasks

Description

Details

1.01 Experiment

--- TPR ---

Temperature Programmed

1.02 Instrument Settings

--- Instrument Settings ---

Carrier: Ar @ 45.00 (None @ 50.00)

Loop: H2 @ 5.00 (None @ 50.00)

(Fill) (Analyze) Trap

1.03 Wait

Filaments:245.0 °C (Disabled)

--- Wait ---

Wait until baseline and temperatures are stable.

Serial # 0001 Unit 1 Port 1

Sample: CuO - Lot# 13CuO-02

Operator: PV

Submitter:

File: C:\Products Folder\ChemiSorb Auto 2730\Specific Sections\13CuO_Run6_Coil Trap.SMP

Started: 8/19/2025 4:56:02 PM

Completed: 8/19/2025 6:14:42 PM

Instrument: 2730

Sample mass: 0.1213 g

Report time: 10/9/2025 12:48:09 PM

Comments: Hold time 30 minutes.

Description	Tasks	Details
1.04 Start Recording	--- Start Recording --- One measurement every 1.00 s Set external trigger: No	
1.05 Temperature Ramp	--- Temperature Ramp --- Type: Sample Temperature: 400.0 °C Ramp rate: 10.0 °C/min Hold time: 30.00 min	
1.06 Stop Recording Termination	--- Stop Recording --- --- Termination --- Carrier: None @ 100.00 (Ar @ 45.00) Loop: None @ 100.00 (H2 @ 5.00)	
	(Fill) (Analyze) Bypass	
	Sample: Ambient (400.0 °C) Rate: Ambient (10.0 °C/min)	
	Filaments: Disabled (245.0 °C)	

Adsorptive Properties

Adsorptive: Argon (Ar)
 Maximum manifold pressure: 123.323 kPa
 Molecular cross-sectional area: 0.143 nm²
 Adsorbate molecular weight: 39.95
 Relative thermal conductivity: 0.68
 Gas blend: No
 Fluid properties: H:\FPI\fpiv7\argon.fpi

Adsorptive: Hydrogen (H2)
 Maximum manifold pressure: 123.323 kPa
 Molecular cross-sectional area: 0.123 nm²
 Adsorbate molecular weight: 2.02
 Relative thermal conductivity: 7.07
 Gas blend: No
 Fluid properties: H:\FPI\fpiv7\hydrogen.fpi

Report Options

Peak Detection/Integration Options
 Baseline mode: Best fit baseline
 Minimum peak height: 0.25 % F.S.
 Peak smoothing: 0 points
 Sensitivity: 1.0e-02 % F.S.

Serial # 0001 Unit 1 Port 1

Sample: CuO - Lot# 13CuO-02

Operator: PV

Submitter:

File: C:\Products Folder\ChemiSorb Auto 2730\Specific Sections\13CuO_Run6_Coil Trap.SMP

Started: 8/19/2025 4:56:02 PM

Completed: 8/19/2025 6:14:42 PM

Instrument: 2730

Sample mass: 0.1213 g

Report time: 10/9/2025 12:48:09 PM

Comments: Hold time 30 minutes.

Peak Detection/Integration Options

Maximum shoulder ratio: 33%

Maximum group separation: 33%

Minimum peak area: 1.0 % F.S./min

Maximum baseline slope: 0.1 % F.S./sec

**This page
intentionally
left blank**



EU DECLARATION OF CONFORMITY

This declaration of conformity is issued under the sole responsibility of the manufacturer:

Micromeritics Instrument Corporation
4356 Communications Drive
Norcross, GA 30093, USA

Hereby declares that the product:

ChemiSorb Auto

is in conformity with the following **EU harmonization legislation**:

2014/35/EU - LVD Directive
2014/30/EU - EMC Directive
2011/65/EU - RoHS Directive

and that the equipment is in conformity with the following harmonized and other appropriate standards;

2014/35/EU (LVD)

IEC 61010-1:2010/A1:2016 - Safety requirements for electrical equipment for measurement, control, and laboratory use — Part 1: General requirements.

IEC 61010-2-010:2019 - Particular requirements for laboratory equipment for the heating of materials.

IEC 61010-2-081:2019 - Particular requirements for automatic and semi-automatic laboratory equipment for analysis and other purposes

2014/30/EU (EMC)

IEC 61326-1:2020 Ed.3 - Electrical equipment for measurement, control and laboratory use — EMC requirements — Part 1: General requirements

IEC 61000-3-2:2018 /AMD1:2020 - Part 3-2: Limits — Limits for harmonic current emissions (equipment input current ≤ 16 A per phase)

IEC 61000-3-3:2013 - Part 3-3: Limits — Limitation of voltage changes, voltage fluctuations and flicker in public low-voltage supply systems, for equipment with rated current ≤ 16 A per phase and not subject to conditional connection

2011/65/EU (RoHS)

EN 63000:2018 - Technical documentation for the assessment of electrical and electronic products with respect to the restriction of hazardous substances

Name: John McCaffrey, Ph.D.

Title: Vice President, R & D

Signature: _____

Date of issue: 10/22/2025

Location: Norcross, GA USA



UK DECLARATION OF CONFORMITY

This declaration of conformity is issued under the sole responsibility of the manufacturer:

Micromeritics Instrument Corporation
4356 Communications Drive
Norcross, GA 30093, USA

Hereby declares that the product:

ChemiSorb Auto

is in conformity with the following UK legislation:

Electrical Equipment (Safety) Regulations 2016
Electromagnetic Compatibility Regulations 2016
Restriction of the Use of Certain Hazardous Substances in E&E Equipment Regulations 2012

and that the equipment is in conformity with the following designated and other appropriate standards;

Electrical Equipment (Safety) Regulations 2016

IEC 61010-1:2010//AMD1:2016 - *Safety requirements for electrical equipment for measurement, control, and laboratory use — Part 1: General requirements.*

IEC 61010-2-010:2019 - *Particular requirements for laboratory equipment for the heating of materials.*

IEC 61010-2-081:2019 - *Particular requirements for automatic and semi-automatic laboratory equipment for analysis and other purposes*

Electromagnetic Compatibility Regulations 2016

IEC 61326-1:2020 - *Electrical equipment for measurement, control and laboratory use — EMC requirements — Part 1: General requirements*

IEC 61000-3-2:2019 - *Part 3-2: Limits — Limits for harmonic current emissions (equipment input current \leq 16 A per phase)*

IEC 61000-3-3:2013 - *Part 3-3: Limits — Limitation of voltage changes, voltage fluctuations and flicker in public low-voltage supply systems, for equipment with rated current \leq 16 A per phase and not subject to conditional connection*

Restriction of the Use of Certain Hazardous Substances in E&E Equipment Regulations 2012

EN 63000:2018 - *Technical documentation for the assessment of electrical and electronic products with respect to the restriction of hazardous substances*

Name: John McCaffrey, Ph.D.

Title: Vice President, R & D

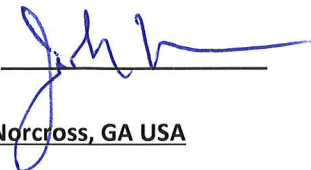
Signature: 

Date of issue: 10/22/2025

Location: Norcross, GA USA