

ChemiSorb HTP

Operator's Manual

Rev D

Adobe Acrobat Reader is a registered trademark of Adobe Systems, Inc.

Alconox is a registered trademark of the Alconox Company.

Kalrez is a registered trademark of DuPont Dow Elastomers L.L.C.

Kimwipe is a registered trademark of Kimberly-Clark Corporation.

Micromeritics is a registered trademark of Micromeritics Instrument Corporation.

Microsoft, Windows, and Windows Vista are registered trademarks of Microsoft Corporation.

Copyright © Micromeritics Instrument Corporation 2012-2019. All rights reserved. Printed in the U.S.A.

The software described in this manual is furnished under a license agreement and may be used or copied only in accordance with the terms of the agreement.

WARRANTY

MICROMERITICS INSTRUMENT CORPORATION warrants for one year from the date of shipment each instrument it manufactures to be free from defects in material and workmanship impairing its usefulness under normal use and service conditions except as noted herein.

Our liability under this warranty is limited to repair, servicing and adjustment, free of charge at our plant, of any instrument or defective parts when returned prepaid to us and which our examination discloses to have been defective. The purchaser is responsible for all transportation charges involving the shipment of materials for warranty repairs. Failure of any instrument or product due to operator error, improper installation, unauthorized repair or alteration, failure of utilities, or environmental contamination will not constitute a warranty claim. The materials of construction used in MICROMERITICS instruments and other products were chosen after extensive testing and experience for their reliability and durability. However, these materials cannot be totally guaranteed against wear and/or decomposition by chemical action (corrosion) as a result of normal use.

Repair parts are warranted to be free from defects in material and workmanship for 90 days from the date of shipment.

No instrument or product shall be returned to MICROMERITICS prior to notification of alleged defect and authorization to return the instrument or product. All repairs or replacements are made subject to factory inspection of returned parts.

MICROMERITICS shall be released from all obligations under its warranty in the event repairs or modifications are made by persons other than its own authorized service personnel unless such work is authorized in writing by MICROMERITICS.

The obligations of this warranty will be limited under the following conditions:

1. Certain products sold by MICROMERITICS are the products of reputable manufacturers, sold under their respective brand names or trade names. We, therefore, make no express or implied warranty as to such products. We shall use our best efforts to obtain from the manufacturer, in accordance with his customary practice, the repair or replacement of such of his products that may prove defective in workmanship or materials. Service charges made by such manufacturer are the responsibility of the ultimate purchaser. This states our entire liability in respect to such products, except as an authorized person of MICROMERITICS may otherwise agree to in writing.
2. If an instrument or product is found defective during the warranty period, replacement parts may, at the discretion of MICROMERITICS, be sent to be installed by the purchaser, e.g., printed circuit boards, check valves, seals, etc.
3. Expendable items, e.g., sample tubes, detector source lamps, indicator lamps, fuses, valve plugs (rotor) and stems, seals and O-rings, ferrules, etc., are excluded from this warranty except for manufacturing defects. Such items which perform satisfactorily during the first 45 days after the date of shipment are assumed to be free of manufacturing defects.

Purchaser agrees to hold MICROMERITICS harmless from any patent infringement action brought against MICROMERITICS if, at the request of the purchaser, MICROMERITICS modifies a standard product or manufactures a special product to the purchaser's specifications.

MICROMERITICS shall not be liable for consequential or other type damages resulting from the use of any of its products other than the liability stated above. This warranty is in lieu of all other warranties, express or implied, including, but not limited to, the implied warranties of merchantability or fitness for use.

4356 Communications Drive • Norcross, GA 30093-2901 • Fax (770) 662-3696

Domestic Sales - (770) 662-3636
International Sales - (770) 662-3660

Domestic Repair Service - (770) 662-3666
Customer Service - (770) 662-3636

TABLE OF CONTENTS

1. GENERAL DESCRIPTION

Organization of the Operator's Manual	1-1
Conventions	1-3
System Description	1-4
Software	1-4
Specifications	1-5

2. USER INTERFACE

Instrument Components and Connectors	2-1
Front Panel	2-1
Rear Panel	2-3
Right Side Panel	2-4
Turning the Analyzer On and Off	2-5
Turning On the Analyzer	2-5
Turning Off the Analyzer	2-5
Using the Software	2-6
Shortcut Menus	2-6
Shortcut Keys	2-6
File Name Conventions	2-7
Menu Structure	2-8
Windows	2-9
Help Menu	2-9

3. OPERATIONAL PROCEDURES

Specifying Sample Defaults	3-1
Advanced Format	3-1
Basic Format	3-3
Opening Files	3-4
Creating a New File	3-5
Opening an Existing File	3-5
Defining Parameter Files	3-6
Analysis Conditions	3-6
Report Options	3-7
Creating a Sample Information File	3-9
Advanced Format	3-9
Basic and Restricted Formats	3-10
Preparing for Analysis	3-12
Cleaning and Labeling Sample Tubes	3-12
Determining the Sample Mass	3-15
Installing the Sample Tube	3-19
Performing an Analysis	3-22

Sample Analysis	3-22
Sequence Analysis	3-23
Printing File Contents	3-25
Listing File Statistics	3-27
Exporting Isotherm Data	3-29
Generating Graph Overlays	3-31

4. SOFTWARE AND SETUP MODIFICATIONS

Installing the Software	4-1
Using the Setup Program for Other Functions	4-4
Starting the Setup Program	4-4
Installing Software Updates or Reverting to a Previous Version	4-5
Adding an Analyzer	4-6
Ethernet Switch	4-6
Software	4-7
Moving an Analyzer from One Computer to Another Computer	4-8
Removing an Analyzer	4-12
Changing the Analyzer Setup Configuration	4-13
Reinstalling Calibration Files	4-15
Uninstalling the Analysis Program	4-16

5. FILE MENU

Description	5-1
Open	5-3
Sample Information	5-4
Advanced Format	5-5
Basic Format	5-8
Restricted Format	5-11
Analysis Conditions	5-12
Analysis Tasks	5-14
Evacuation	5-14
Flow	5-16
Leak Test	5-16
Soak	5-18
Analysis	5-19
Report Options	5-25
Isotherm Report Options	5-30
Difference Method Report Options	5-32
Sinfelt Method Report Options	5-34
Langmuir Surface Area Report	5-35
Freundlich Report	5-36
Temkin Report	5-38
Options Report	5-40
Sample Log	5-40
Collected/Entered Data	5-41
Save	5-44
Save As	5-44
Save All	5-44

Close.....	5-44
Close All.....	5-44
Print.....	5-45
List.....	5-47
Export.....	5-48
Format of Data Output.....	5-50
Exit.....	5-51

6. UNIT MENU

Description.....	6-1
Sample Analysis.....	6-3
Analysis Sequence.....	6-8
Enable Manual Control.....	6-13
Show Instrument Schematic.....	6-18
Show All Readings.....	6-19
Show Status.....	6-20
Show Instrument Log.....	6-22
Unit Configuration.....	6-24
Calibration.....	6-26
Pressure Zero.....	6-26
Match Transducers.....	6-27
Servo.....	6-27
Save to File.....	6-28
Load from File.....	6-28

7. REPORTS MENU

Description.....	7-1
Start Report.....	7-2
Close Reports.....	7-4
Open Report.....	7-4
Heat of Adsorption Report.....	7-5
Printed Reports.....	7-9
Header.....	7-9
Onscreen Reports.....	7-9
Tool Bar.....	7-10
Shortcut Menus.....	7-13
Tabular Reports.....	7-13
Graphs.....	7-14
Zoom Feature.....	7-17
Axis Cross Hair.....	7-17
Report Examples.....	7-18
Isotherm.....	7-19
Plot.....	7-19
Tabular Report.....	7-20
Difference Method.....	7-21
Summary.....	7-21
Tabular Report.....	7-22

Plot	7-23
Sinfelt Method	7-24
Langmuir Surface Area.....	7-25
Options Report	7-26
Page 1	7-26
Page 2	7-27

8. OPTIONS MENU

Description	8-1
Option Presentation	8-2
Advanced	8-3
Basic	8-4
Restricted	8-5
Sample Defaults	8-6
Advanced	8-6
Basic	8-9
Active Metals Defaults.....	8-12
Gas Defaults / MFC Constants	8-14
Units	8-16
Graph Grid Lines	8-16
Thermal Transpiration on Live Graph	8-17
Parameter Files Directory.....	8-17
Service Test Mode	8-17

9. TROUBLESHOOTING AND MAINTENANCE

Troubleshooting	9-1
Preventive Maintenance	9-2
Lubricating Elevator Drive Assembly	9-3
Cleaning the Analyzer	9-4
Replacing the Sample Tube O-rings.....	9-4
Replacing the Port Filters and O-rings	9-6
Connecting Gases	9-9
Guidelines for Connecting Gases to the Analyzer	9-9
Disconnecting the Depleted Bottle.....	9-9
Connecting a Replacement Gas Bottle	9-10
Specifying Gas Ports.....	9-13

10. ORDERING INFORMATION

A. ERROR MESSAGES

2200 and 2400 Series	A-1
2500 Series	A-12
4000 Series	A-20
6000 and 6100 Series	A-23

6200 Series	A-24
6500 Series	A-32

B. CALCULATIONS

Real Gas Equation of State	B-1
Free Space	B-1
Quantity Adsorbed	B-3
Weighted Metal Parameters	B-4
Difference and Sinfelt Methods	B-4
Metal Dispersion	B-5
Metallic Surface Area	B-5
Crystallite Size	B-5
Langmuir Surface Area	B-6
Freundlich Isotherm	B-7
Temkin Isotherm	B-8

C. GAS CONVERSION CONSTANTS

Gas Mixtures	C-5
--------------------	-----

D. ATOMIC WEIGHTS AND CROSS-SECTIONAL AREAS FOR SELECTED METALS

E. FORMAT OF EXPORTED DATA

INDEX

1. GENERAL DESCRIPTION

This operator's manual provides a description of the ChemiSorb HTP, its menu options, and operating instructions.

To help you operate the ChemiSorb more efficiently:

- read Chapter 2, User Interface, before operating the analyzer and its software
- use the step-by-step instructions in Chapter 3 when performing common operations

Log in to your customer portal on the Micromeritics web page to access parts and accessories.

Organization of the Operator's Manual

This operator's manual is organized as follows:

- | | |
|------------------|---|
| Chapter 1 | GENERAL DESCRIPTION
Provides a general description of the ChemiSorb HTP, its features, and specifications. |
| Chapter 2 | USER INTERFACE
Provides instrument and software interface. |
| Chapter 3 | OPERATIONAL PROCEDURES
Provides step-by-step procedures for the operations performed with the ChemiSorb HTP. |
| Chapter 4 | SOFTWARE AND SETUP MODIFICATIONS
Provides instructions for installing software updates and for modifying analyzer setup configurations. |
| Chapter 5 | FILE MENU
Provides a description of the choices available on the File menu. |
| Chapter 6 | UNIT MENU
Provides a description of the choices available on the Unit menu. |
| Chapter 7 | REPORTS MENU
Provides a description of the choices available on the Reports menu. |

- Chapter 8** **OPTIONS MENU**
Provides a description of the choices available on the Options menu.
- Chapter 9** **TROUBLESHOOTING AND MAINTENANCE**
Provides user maintenance and service information.
- Appendix A** **ERROR MESSAGES**
Lists the error messages that may be displayed by the software and includes a cause and action for each.
- Appendix B** **CALCULATIONS**
Provides the calculations used by the ChemiSorb program.
- Appendix C** **GAS CONVERSION CONSTANTS**
Provides gas conversion constants for the MFC.
- Appendix D** **ATOMIC WEIGHTS AND CROSS-SECTIONAL AREAS FOR
SELECTED METALS**
Lists the atomic weights and cross-sectional areas of selected metals.
- Appendix E** **FORMAT OF EXPORTED DATA**
Contains the format and description of exported data.
- Index** **INDEX**
Provides quick access to a subject matter.

Conventions

This manual uses the icons shown below to identify notes of importance, cautions, and warnings.



Notes contain important information pertinent to the subject matter.



Warnings contain information that helps you prevent actions that may cause personal injury.



Cautions contain information that helps you prevent actions that may damage the analyzer or one of its components.

System Description



The ChemiSorb HTP is a high-throughput chemisorption analyzer that measures the extent of active surface in a catalyst by exposing a sample of the catalyst to a reactive gas at a controlled temperature. It contains six ports, allowing six analyses to run concurrently. Each port is equipped with a furnace enabling independent control of sample temperature and ramping. A mass flow controller is also installed in each port to ensure accurate and reproducible flow through the sample.

Software

The ChemiSorb analysis program operates in a Windows® environment. This allows other applications to run while an automatic operation is in progress.

The report system provided in the analysis program allows the manipulation and customization of reports. Zoom in on portions of the graphs or shift the axes to examine fine details. Graphs and data can be copied to the clipboard and pasted into other applications. Reports can be customized with a choice of fonts and a company logo added to the report header.

Specifications

The ChemiSorb HTP has been designed and tested to meet the specifications provided below.

Characteristic	Specification
Electrical	
Voltage:	100/115/230 VAC
Power:	1300 VA, maximum (exclusive of vacuum fore pump which is powered separately)
Frequency:	50 or 60 Hz
Environment	
Temperature:	10 to 35 °C (50 to 95 °F), operating; -10 to 55 °C (14 to 131 °F), storing or shipping
Humidity:	Up to 90% noncondensing (for instrument) 20 to 80% (for computer system)
Physical	
Height:	159 cm (63 in.)
Width:	103 cm (41 in.)
Depth:	51 cm (20 in.)
Weight:	215 kg (475 lbs)
Analysis	
Capacity:	Six sample ports
Manifold Temperature	
Type:	Platinum resistance device (RTD), one per port and one in dosing manifold
Accuracy:	± 0.02 °C
Stability:	± 0.1 °C per month
Gas Flow Control	
Type:	Mass Flow Controller, one per port
Range:	0 to 200 sccm (nitrogen equivalent flow rate)
Accuracy:	Full scale ±1%
Gas Dosing	
Accuracy:	0.05 cm ³ STP, normal doses 0.01 cm ³ STP, low-pressure doses

Characteristic	Specification
Pressure Measurement	
Analysis Manifold Transducers:	
Range:	0 to 950 mmHg
A to D Resolution:	0.001 mmHg, 1000-mmHg transducer 0.00001 mmHg, 10-mmHg transducer
Accuracy:	Within 0.15% of reading, 1000- and 10-mmHg transducers (Includes nonlinearity, hysteresis and nonrepeatability; transducer manufacturer's specifications.)
Sample Port Transducers:	
Range:	0 to 1000 mmHg
A to D Resolution:	0.001 mmHg, 1000-mmHg transducer 0.00001 mmHg, 10-mmHg transducer
Accuracy:	Within 0.5% of reading, 1000- and 10-mmHg transducers (Includes nonlinearity, hysteresis, and nonrepeatability; transducer manufacturer's specifications.)
Vacuum Gauge	
Type:	Thermocouple gauge tube
Range:	0 to 100 μ mHg
On-screen Resolution:	0.1 μ mHg
Furnace System	
The ChemiSorb HTP has six independent furnaces, one for each sample port with temperature monitoring of the furnace and sample tube.	
Temperature Range:	10 °C above ambient to 700 °C
Accuracy:	± 1.0 °C
Stability:	± 0.5 °C up to 50 °C; ± 1.0 °C from 50 to 700 °C
Ramp Range:	1 to 20 °C/min up to 500 °C; 1 to 10 °C from 500 to 700 °C
Cool down:	From 700 to 10 °C above ambient in less than 60 minutes
Temperature increment:	1 °C
Thermocouples:	12 type K thermocouples
Vacuum System	
Diaphragm pump:	Two-stage, ultimate vacuum less than 3 mmHg
High-vacuum pump:	Less than 3.8×10^{-9} mmHg, measured by pump manufacturer according to Pneurop Standard 5608

Characteristic	Specification
Computer	
Minimum requirements:	Computer capable of running Windows® 7, Windows XP Professional, or Windows Vista® Business or Ultimate operating system 512 megabytes of main memory 20-gigabytes hard drive Ethernet port (capable of communicating with a 10 base-T ethernet card) CD-ROM drive 1024 × 768 video display capability

2. USER INTERFACE

This chapter contains information to familiarize you with the hardware and software components of the ChemiSorb HTP. It is recommended that you read this chapter before attempting to operate the ChemiSorb analyzer.

Instrument Components and Connectors

Front Panel

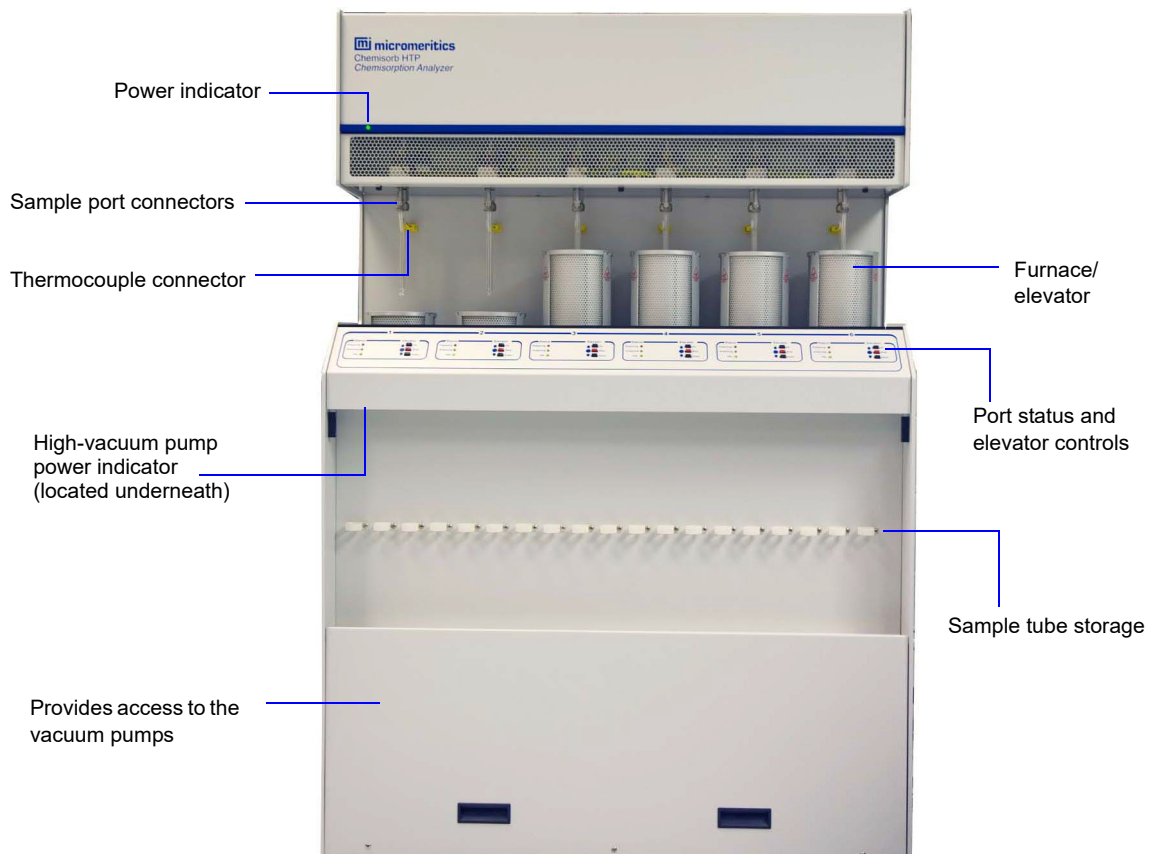

Power indicator

Illuminates when analysis program is initiated and ready for operation

Sample port connector

For installing the sample tube; one for each port

Thermocouple connector	For attaching the thermocouple, one for each port
Furnace/elevator	The furnace resides on the elevator and is operated using the buttons on the Port status pad.
Port status Elevator control	Each port has a status indicator and elevator control.



Indicate port status

Control elevator movement

The indicator lights on the left side illuminate to reflect the state of the port.

The elevator buttons on the right side function as follows:

Up raises the elevator to its uppermost position.

Down lowers the elevator to its lowest position.

Stop will stop the elevator at its current position.

**High-vacuum pump
power indicator**

Illuminated when power is applied to the high-vacuum pump and the pump is running at the correct speed.

Sample tube storage

For convenient storage of sample tubes.

Rear Panel

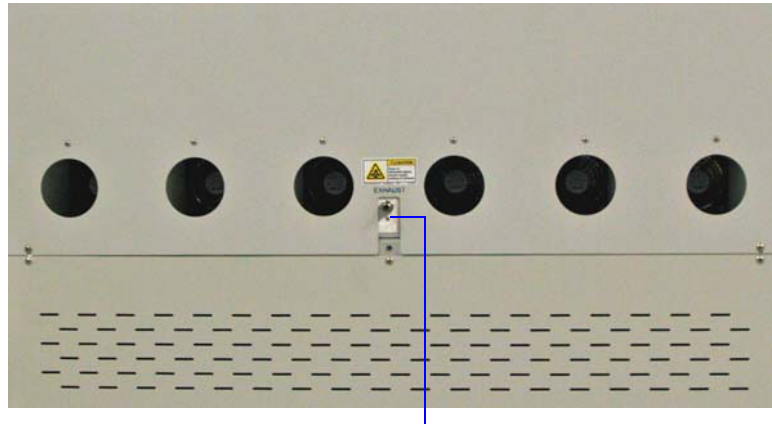

Exhaust connector

Exhaust connector

For certain gases it is necessary to vent the gases via an external venting system. This connector is used to attach an external exhaust system.



When using dangerous gases, an exhaust system must be used to vent gas fumes.

Right Side Panel

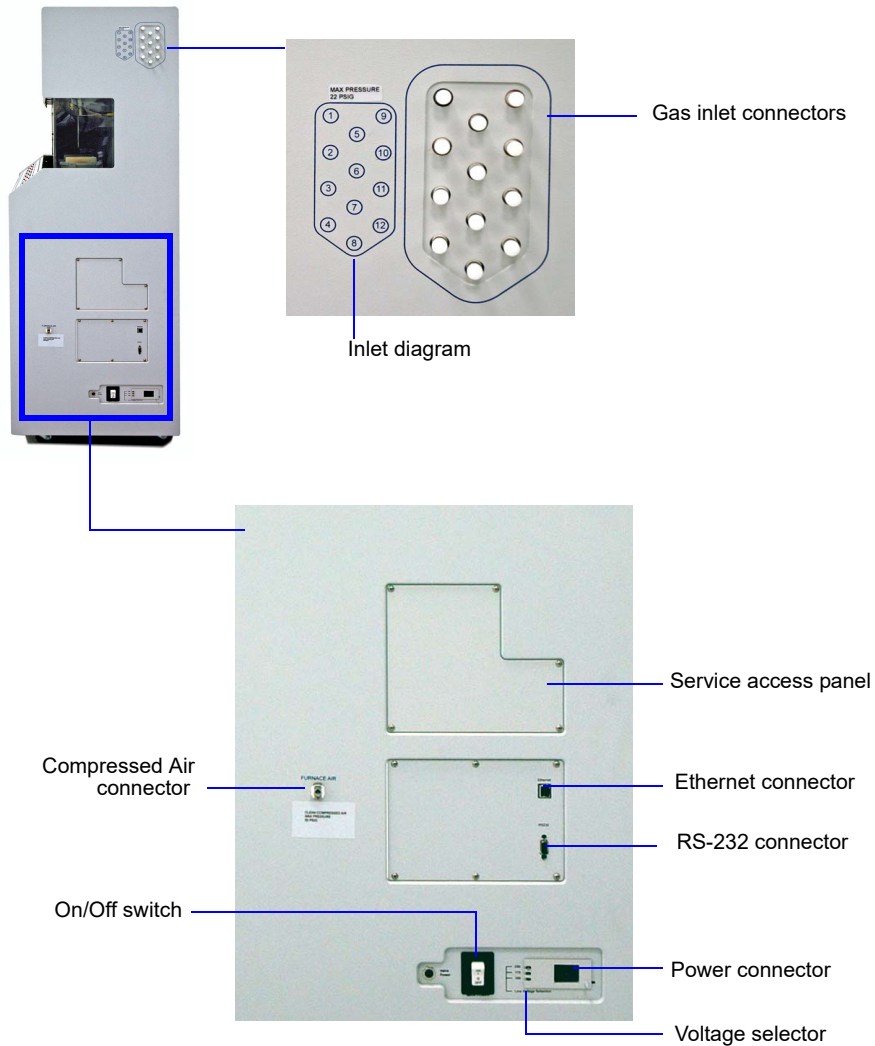

Gas inlet connectors

For attaching analysis gases

Inlet diagram

Provides a pictorial representation of inlet connectors. Use these numbers when assigning gas ports on the Gas Configuration dialog (see page [6-25](#)).

Compressed air connector

For connecting a compressed air (or nitrogen) supply to cool the furnace



Compressed air is released into a hot furnace. Be sure air is clean and dry. Oily or wet air may cause dangerous conditions, resulting in personal injury or damage to the instrument.

Ethernet connector	For connecting the ethernet cable, allowing communication between the analyzer and the computer
RS-232 connector	Used by service personnel to perform calibration procedures.
On/Off switch	For turning the analyzer on and off
Power connector	For connecting the power cord
Voltage selector	For selecting the proper operating voltage

Turning the Analyzer On and Off

Turning On the Analyzer

1. Place the On/Off switches for the computer and all peripheral devices in the ON position.
2. Place the analyzer On/Off switch in the ON position.

Turning Off the Analyzer



Always exit the analysis program and the Windows application before turning off the computer. Failure to do so could result in loss of data.

1. Select **Close** from the **System** menu or **Exit** from the **File** menu.

If an analysis is in progress, the following message is displayed:

2459- An Instrument is busy. A delay in restarting this application could result in loss of new data. Continue program exit?

Yes

No

If you click **Yes** and the analysis program closes, the analysis continues and data continue to be collected. Reports that are queued under the Print Manager will print. If, however, a power failure occurs and an uninterruptible power supply (UPS) is not attached to the analyzer, the data collected *after exiting* the analysis program are lost.

2. Place the On/Off switches for the computer and all peripheral devices in the OFF position.
3. Place the analyzer On/Off switch in the OFF position.

Using the Software

The ChemiSorb program requires familiarity with standard Windows operations such as using the mouse, menus, and dialog boxes. While this manual provides brief instructions for such standard operations, refer to the operating system documentation or to its online help system to clarify functions which are specific to Windows.

Shortcut Menus

Shortcut menus (sometimes referred to as context-sensitive menus or pop-up menus) are available for onscreen graphs, tabular reports, and components on the instrument schematic. These menus are accessed by selecting the item to display its menu and clicking the right mouse button. For example, right-click in a column of an onscreen report and the following menu is displayed.



Shortcut Keys

Shortcut keys can be used to activate some menu commands. Shortcut keys or key combinations (if assigned) are listed to the right of the menu item. Instead of opening the menu and choosing the command, press the key combination. For example, to open a sample information file, press **F2**; the Open Sample Information dialog is displayed.

Use shortcut keys to access a menu or any function that contains an underlined letter by pressing **Alt** plus the underlined letter in the command. For example, press **Alt**, then **F** to access the **File** menu.

The following table provides a list of the Shortcut keys available for the ChemiSorb program.

Key(s)	Function
F1	Access electronic copy of operator's manual
F2	Open a sample information file
F3	Open an analysis conditions file
F5	Open a report options file
F6	Tile windows
F7	Cascade windows
F8	Start a report
F9	Close all open reports
F10	Generate a Heat of Adsorption report
Alt + F4	Exit the analysis program
Shift + F2	List sample information files
Shift + F3	List analysis conditions files
Shift + F5	List report options files
Shift + F9	Access shortcut menu for (1) selected component on instrument schematic, or (2) onscreen reports

File Name Conventions

For sample information files, a default file name (the next available sequence number) and a default extension display. For Analysis conditions and Report options, only a default extension displays.

The following table shows the file name extensions for the ChemiSorb program.

Default File Name Extensions

File Type	Extension
Sample information	SMP
Analysis conditions	ANC
Report options	RPO
Report	REP
Spreadsheet	XLS
ASCII	TXT

Menu Structure

All functions for the ChemiSorb program are located on menus which are accessed from the Menu bar. Each menu contains commands and, in some cases, a submenu. A submenu is indicated when the command is followed by an arrow.

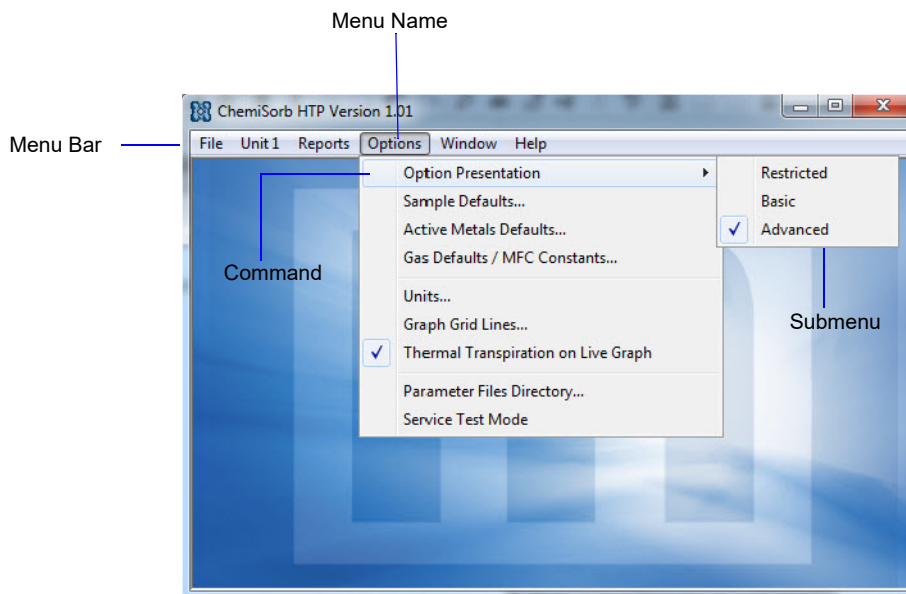

Brief descriptions of each menu are provided below; refer to the chapter given in parentheses for a detailed description of the options contained on that menu.

File	Use to manage sample and parameter files. (Chapter 5, FILE MENU)
Unit [n]	Use to perform analyses. A unit menu is displayed for each attached unit. (Chapter 6, UNIT MENU)
Reports	Use to generate, open, and close reports. (Chapter 7, REPORTS MENU)
Options	Use to edit sample defaults and select data presentation formats. (Chapter 8, OPTIONS MENU)
Windows	Use to arrange the windows and icons on your screen. It also displays the names of all open windows. (this chapter, page 2-9)
Help	Provides access to the online manual. (this chapter, page 2-9)

Windows

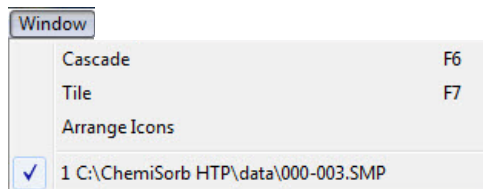

Use these commands to arrange open windows and icons.

Cascade	Resizes all open windows and arranges them in a stacked fashion. The active window is positioned on top of the stack. Each window's title remains visible.
Tile	Resizes all open windows and arranges them side by side so that the contents of all open windows are visible.
Arrange Icons	Arranges the symbols for all minimized windows in an orderly manner.

The Windows menu also displays all open files; the active window is preceded with a check mark.

Help Menu

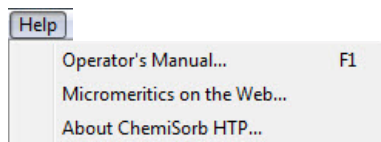

Operator's Manual	Provides a copy of the ChemiSorb operator's manual in Adobe® PDF format.
Micromeritics on the Web	Provides a link to the Micromeritics web site.
About ChemiSorb HTP	Displays information about the ChemiSorb program.

3. OPERATIONAL PROCEDURES

This chapter contains step-by-step procedures for operating the ChemiSorb analyzer. It does not provide detailed descriptions of the fields in the dialogs used to perform these procedures. Chapters 5 through 8 contain details for the dialogs.

Maintenance procedures are described in Chapter 9.

Specifying Sample Defaults

Sample information files include the information required by the analyzer to perform an analysis and collect data. The software automatically generates sample information file names and assigns the default values which you specify. Sample defaults allow the customization of sample files as well as the file name sequence. It is best to specify defaults for materials that are most commonly analyzed. Values can be edited when the sample file is created.

Sample defaults can be specified using the Advanced or Basic format.

Advanced Format

The values you specify in the parameter portions of the Advanced sample file (Analysis Conditions and Report Options) are saved as the defaults for newly created parameter files.

For example, after specifying defaults for a sample file in the Advanced format:

- Select **File > Open > Sample Information**, click **Open**, then **Yes** to create the file, and the defaults you specify display for all parameters.
- Select **File > Open > Analysis Conditions**, enter a file name; click **Open**, then **Yes** and the defaults you specify in the Analysis Conditions portion of the Advanced Sample Defaults dialog display in the fields.

See [Advanced](#), page [8-6](#) for a detailed description of the fields on this dialog.

1. Select **Options > Sample Defaults**; the Sample Defaults dialog is displayed.

2. In the **Sequence** field, specify a default string. This is the number that is incrementally sequenced and displays in the **File name** field when you select **File > Open > Sample information**.
3. In the field to the right of the **Sample** line, enter a format for the identification. Include the \$ symbol to have the sample file number/name included as part of the identification.

The field label can be edited - for example - enter **Material**.

4. Edit the **Operator** and **Submitter** lines or select **Omit** to omit these fields.
5. If bar code information is not applicable, select **Omit** to omit this field from the sample information dialog. Or, use this line for some other type of information, edit the label (or not enter a label name).
6. Enter a sample mass or have it calculated automatically; select a method.
 - **Enter**: enter a default value in the **Mass** field.
 - **Calculate**: enter default values in the **Empty tube** and **Sample+tube** fields
7. Click the Analysis Conditions tab and specify appropriate analysis conditions. See [Analysis Conditions](#), page 3-6 for detailed instructions.

- Click the Report Options tab and specify report options. See [Report Options](#), page 3-7 for detailed instructions.
- Click **Save**, then **Close**.

Basic Format

Perform the following steps to establish defaults for a sample information file in the Basic format. The defaults you establish with this format also serve as defaults for files created using the Restricted format.

When specifying defaults in the Basic format, you will have to select default parameter files. To define parameter files before entering sample defaults, see [Defining Parameter Files](#), page 3-6).

See [Basic](#), page 8-9.

- Select **Options > Sample Defaults**; the Sample Defaults dialog is displayed.

The screenshot shows the 'Sample Defaults' dialog box. The title bar reads 'C:\ChemiSorb HTP\2480.SMP'. The dialog contains the following elements:

- Sequence:** A text box containing '300-000'.
- Sample:** A text box containing '\$'.
- Operator:** A text box that is empty, with an 'Omit' checkbox to its right.
- Mass:** A section with two radio buttons: 'Enter' (selected) and 'Calculate' (unselected).
- Sample Mass:** A text box containing '0.5000 g'.
- Sample + tube:** A text box containing '1.5000 g'.
- Empty tube:** Two text boxes containing '1.0000 g' and '0.5000 g'.
- Analysis Conditions:** A dropdown menu.
- Report Options:** A dropdown menu showing 'Report Options'.
- Replace All...:** A button.
- Buttons:** 'Save', 'Close', and a dropdown menu showing 'Basic'.

- In the **Sequence** field, specify a default string. This is the number that is incrementally sequenced and displays in the **File name** field when you select **File > Open > Sample information**.
- In the field to the right of the **Sample** line, enter a format for the identification. Include the \$ symbol to have the sample file number/name included as part of the identification.

The label (**Sample**) may be edited; for example, enter **Material**.

4. Enter a sample mass or have it calculated automatically; select the method.
 - **Enter**: enter a default value in the **Mass** field.
 - **Calculate**: enter default values in the **Empty tube** and **Sample+tube** fields
5. Select the down arrow to the right of the following fields to select default parameter files:
 - Analysis Conditions
 - Report Options
6. Click **Save**, then **Close**.

Opening Files

File > Open opens a sample information or a parameter file an Open File window similar to the example below is displayed.

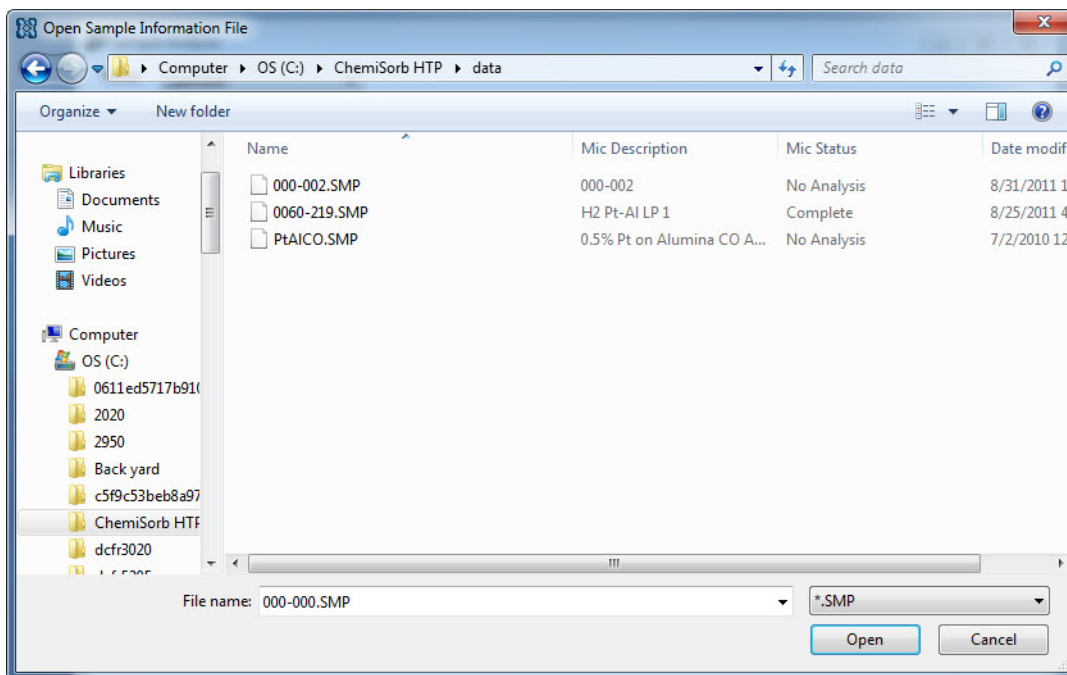

- **Sample Information files** - the **File name** field contains the next sequential file name generated by the program. The sample information file extension is **.SMP**.

- **Parameter files** - the **File name** text box contains an asterisk (*) and a default file extension depending on the type of parameter file selected. Default file extensions are:

- *.ANC Analysis Conditions

- *.RPO Report Options

Creating a New File

1. Select **File > Open > (file type)**.
2. Enter the new file name in the **File name** text box or, for a sample information file, you can accept the default name.
3. Click **Open**.
4. At the prompt, click **Yes** to create a new file.

Opening an Existing File

1. Select **File > Open > (file type)**.
2. The files in the active directory are displayed. You can navigate to another directory if you want to open or create a file in a different directory.
3. Click a file in the files list, then click **Open**.

Defining Parameter Files

The following file types can exist as part of the sample information file, as well as individual parameter files:

- Analysis conditions
- Report options

Having these files exist independently allows multiple use.

Several predefined parameter files are included with the analysis program. Although these files may come close to the needs of your laboratory, define additional ones or use a predefined file as a starting point. Do this by creating a new file and then clicking **Replace**. A dialog is displayed to select the existing parameter file. Then can be made and the original file remains unchanged.

Be sure to save these files to the directory specified as the Parameter File directory, or they will not be included in the drop-down lists on the Basic and Restricted sample information dialogs. Unless the parameter file directory has been changed, the software defaults to the correct directory (see [Parameter Files Directory](#), page 8-17).

Analysis Conditions

Analysis conditions specify the data used to guide an analysis.

See [Analysis Conditions](#), page 5-12.

1. See [Creating a New File](#), page 3-5 to open the Analysis Conditions window.

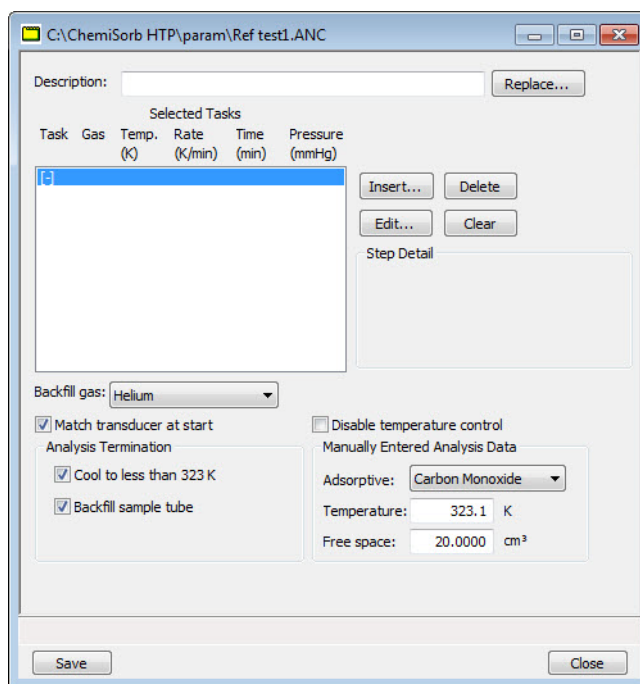

2. Enter a description in the **Description** field; use an intuitive description so that you can recognize it easily.
3. Click **Insert** to insert tasks for the analysis; the Select a task dialog is displayed.

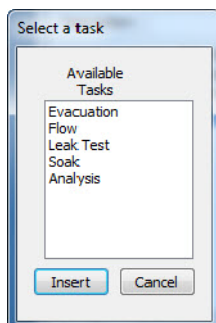

4. Select a task, then click **Insert**.

Each task has an associated dialog, which contains appropriate parameters for that task. Define parameters for each task. Only one Analysis task may be inserted.

5. Click **Save**, then **Close**.

Report Options

Report options files specify the type of reports which can be generated from an analysis or from manually entered data. They also contain report details such as axis scale, axis range, and column headings. These report options files may be used to generate reports automatically at any time during or after the analysis. Of course, reports generated during analysis can only report on data collected up to the time of the report.

Report options files may contain tabular reports only, plots only, or both tabular reports and plots. They may also contain user-defined report tables.

Report options files also may be defined to include overlay options. The ChemiSorb program can overlay up to eight plots of different samples onto a ninth plot of the same type. See [Generating Graph Overlays](#), page 3-31 for instructions on generating overlays.

See [Report Options](#), page 5-25 for a detailed description of the fields on this dialog.

1. See [Creating a New File](#), page 3-5 to open the Report Options window.

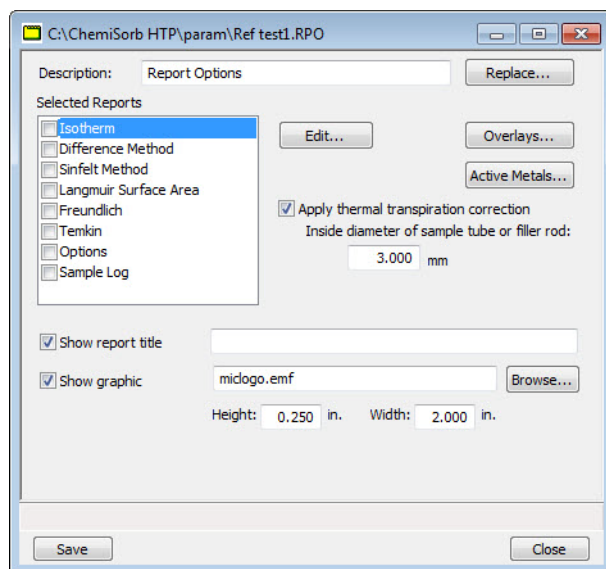

2. Enter a description in the **Description** field. Enter an identifier that gives an intuitive description of the file's contents.
3. The reports that may be generated are listed in the **Selected Reports** list.
 - a. Click the check box for the reports to include in this file; this inserts a check mark and indicates they are selected.
 - b. Click **Edit** to specify report options; be sure the report is highlighted and selected.
4. Select **Apply thermal transpiration correction** to correct for thermal transpiration in the sample tube, then enter the inside diameter of the sample tube (or filler rod when used).
5. To compare the same type of graph from multiple files, click **Overlays** and select the files. Then be sure you edit the graph from the **Selected Reports** window and select **Samples** from the **Overlay** drop-down list.
6. Select **Show report title** and enter the title to appear at the top of the report. Deselect to omit a report title.



If a company logo exists as a bitmap (bmp) or enhanced metafile (emf), it can display in the report header by selecting Show graphic. Click Browse to select the file; use the Height and Width fields to specify the size.

7. Click **Save**, then **Close**.

Creating a Sample Information File

Whether sample files are created in advance or at the time of analysis, a sample information file must be created for each analysis. The sample information file consists of information groups which, collectively, identify the sample, guide the analysis, and specify report options.

A sample file may be created in any of the following formats:

- Advanced
- Basic
- Restricted

Select **Options > Options Presentation** to select a format (see [Option Presentation](#), page 8-2 for additional information).

Advanced Format

The Advanced format presents all parts of the sample file in an index card manner. Use this format to customize sample files.

See [Advanced Format](#), page 5-5 for a detailed description of the fields on this dialog.

1. See [Creating a New File](#), page 3-5 to open the Sample Information file window.

These fields may not display if omitted in sample defaults.

The screenshot shows the 'Sample Information' dialog box. A blue box highlights the 'Operator:', 'Submitter:', and 'Bar Code:' fields. A blue arrow points from the text 'These fields may not display if omitted in sample defaults.' to this box. The dialog also shows 'Sample:' with '300-002', 'Mass' settings (Sample Mass: 0.5000 g, Sample + tube: 1.5000 g, Empty tube: 1.0000 g and 0.5000 g), 'Type of Data' (Automatically collected selected), and 'Comments'.

2. Enter a description in the **Sample** field, or edit the one specified in sample defaults.
3. In the **Operator** field, enter the name of the person who will be performing the analysis.

4. In the **Submitter** field, enter the name of the department, company, etc. submitting the sample for analysis.
5. Enter bar code information (if used). This field (as well as the Operator and Submitter fields) will also accept input from a bar code reader (connected to a USB port on the computer).
6. Select **Enter** to enter a value for the sample's mass (if different from the default value), or **Calculate** to have the mass calculated automatically. If you select **Calculate**, you must enter weights for the **Empty tube** and the **Sample + tube**.
7. Select if data will be manually entered or collected.
8. After completing the Sample Information dialog, click the parameter tabs to open associated dialogs to edit parameters. See [Defining Parameter Files](#), page 3-6.
9. Click **Save**, then **Close**.

Basic and Restricted Formats

Use the Basic and Restricted formats to create a sample file using predefined parameter files (explained in this chapter beginning on page 3-6).

- If using the Basic format, switch to the Advanced format when editing is required.
- If using the Restricted format, you cannot switch to Advanced and edit parameter files.

See [Basic Format](#), page 5-8.

1. See [Creating a New File](#), page 3-5 to open the Sample Information window.

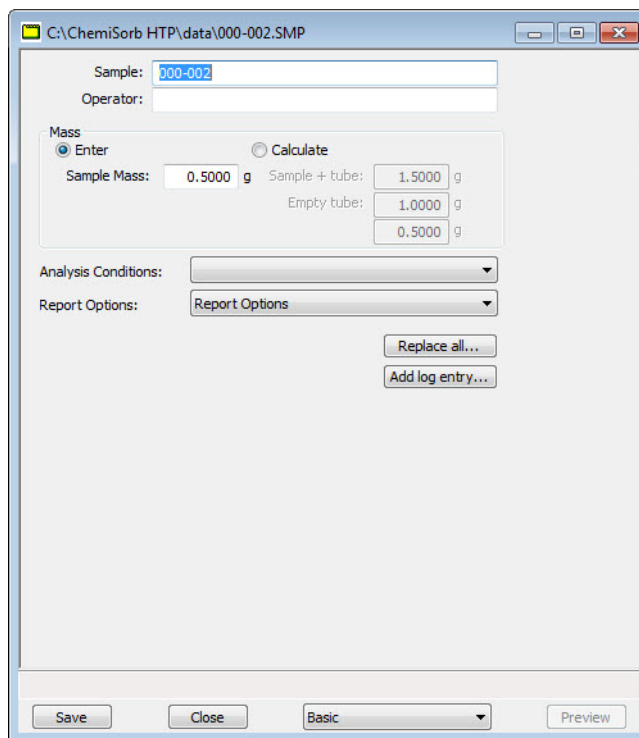

2. Enter a description in the **Sample** field, or edit the one specified in sample defaults.
3. Enter the name of the technician that will perform the analysis.
4. Select **Enter** to enter a value for the sample's mass (if different from the default value), or **Calculate** to have the mass calculated automatically. If you select **Calculate**, you must enter weights for the **Empty tube** and the **Sample + tube**.
5. Click the down arrow to the right of each of the **Analysis Conditions** and **Report Options** fields to select parameter files.



If there is a sample file containing the values for this file, click Replace All to select the file and copy the values into the current file.

6. Click **Save**, then **Close**.

Preparing for Analysis

The table shown here outlines the tasks necessary to properly prepare for an analysis, as well as the location of the procedure for performing the task. It is best to perform the tasks in the order given in the table.

Task	Name and Location
Clean the sample tube	Cleaning and Labeling Sample Tubes , page 3-12
Create the sample file	Creating a Sample Information File , page 3-9
Weigh your sample	Determining the Sample Mass , page 3-15
Load sample on sample port	Installing the Sample Tube , page 3-19

Cleaning and Labeling Sample Tubes

Sample tubes and filler rods must be clean and dry before samples are added and weighed. See the table below for a list of materials needed to clean and weigh samples.

Supplied by Micromeritics	Supplied by User
Sample tube	Drying oven
Filler rod (if used)	Ultrasonic cleaning unit
Stoppers for sample tube	Detergent
Sample tube brush	Rubber gloves or lint-free cloth
Sample tube rack	Isopropyl alcohol
Sample weighing support	Safety glasses
Quartz wool	Analytical balance
	Pipe cleaners

1. Turn on the drying oven used for heating the sample tubes and filler rods and set the temperature to 110 °C.
2. Check the reservoir of the ultrasonic cleaning unit to make sure it is clean.
3. Using five grams of Alconox[®] (or other suitable detergent) per 500 mL of warm water, fill the reservoir of the ultrasonic unit with enough water to cover the sample tubes and filler rods. Make sure the detergent is dissolved before placing the sample tubes and filler rods into the water. If too much detergent is used, it may be difficult to rinse from the sample tubes.

4. Fill the sample tubes with warm water and place them and the filler rods in the reservoir of the ultrasonic cleaning unit. Turn on the ultrasonic cleaning unit for approximately fifteen minutes.

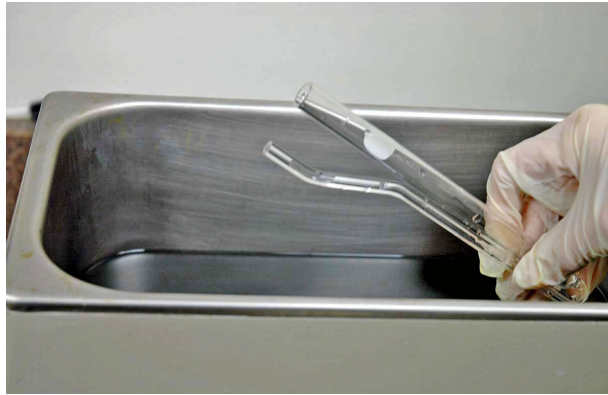

5. Using latex gloves, remove the sample tubes and filler rods from the reservoir.
6. Clean the interior of the sample tubes with the brush supplied with the ChemiSorb System.
7. Rinse the sample tubes and filler rods thoroughly with hot water, then with isopropyl alcohol.



If isopropyl alcohol is not available, deionized water may be used to rinse the sample tubes.

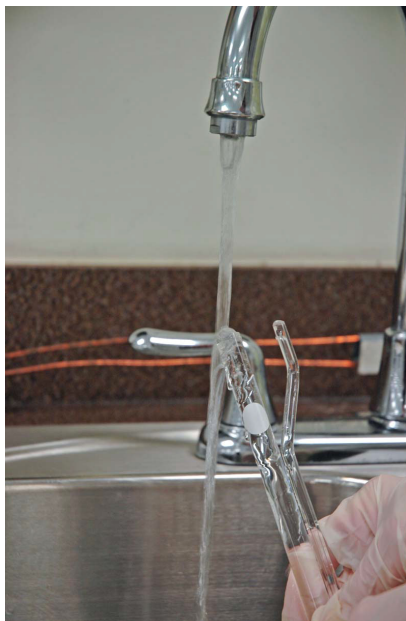

8. Stand the sample tubes on the sample tube rack and place the filler rods in a basket or in the rack. Bake in a vacuum oven for two hours.

9. Remove the sample tubes and filler rods from the oven and allow them to cool.



Do not insert the filler rods at this time. Filler rods are inserted just before the sample tube is installed on the analysis port.

10. Wipe the rubber stoppers with a lint-free cloth.
11. Label the sample tube and stoppers for identification.

Determining the Sample Mass

Carefully weigh each sample tube set and sample as described below.

1. Place the sample weighing support on the balance. Tare the balance and allow it to stabilize at zero (0).
2. If analyzing a powder or sample made of fine particles, push a piece of quartz wool all the way down inside the sample tube.



Then select one of the following:

- If using quartz wool, put a second piece of quartz wool just inside the sample tube.

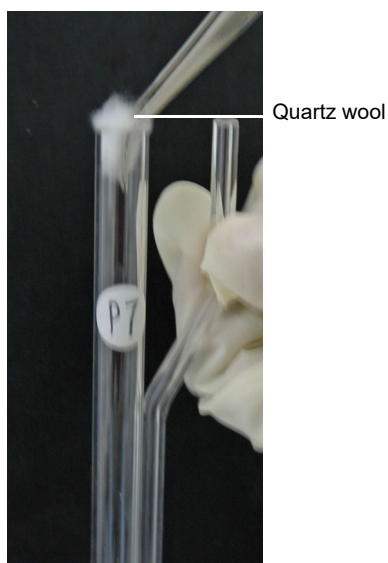

- If using filter disks, push a filter disk down into the tube on top of the quartz wool, and place a second filter disk just inside the sample tube.



3. Place the sample tube set (sample tube with quartz wool or filter disks and the stoppers) on the sample support. Record the stabilized weight as the **Empty tube** (contains no sample).



4. Remove the sample weighing support and sample tube set from the balance.
5. Place a sample container on the balance; allow the balance to stabilize at zero (0).



Do not touch the sample with bare hands while performing the next step. Oil from your fingers could affect the accuracy of results.

6. Slowly add sample (approximately 0.5 to 1.0 gram) to the sample container.
7. If you are analyzing a powder or sample made of fine particles, remove the top portion of quartz wool or the filter disk from the tube.
8. Using a funnel, slowly pour sample from the container into the sample tube on top of the quartz wool remaining in the tube.



Make sure all of the sample in the container is placed in the sample tube to avoid errors caused by incorrect sample weight.

9. Select one of the following:
- If using quartz wool, insert the top portion of quartz wool into the tube and press it down.
 - If using filter disks, insert the filter disk into the tube and press it down.



Make sure the disk is flat on top of the sample. It needs to seal around the edges so there will be no gap allowing the sample to escape.

10. Wipe the top of the sample tube with a lint-free cloth, such as a Kimwipe[®], to remove any quartz wool that may have adhered to its surface.
11. Weigh the sample tube set containing the sample and the stoppers. Record this weight as the **Sample + tube**.
12. Enter the sample mass in your sample file as follows:

If you selected ...	Then ...
Enter	Subtract the empty tube mass from the sample + tube mass. Enter this value in the Sample Mass field.
Calculate	Enter the value you recorded for the sample plus the tube in the Sample + tube field.
	Enter the value you recorded for the empty tube in the Empty tube field.



The value entered for Mass is used in report calculations; therefore, it should be exact. To ensure accuracy, reweigh the sample after analysis. If the value is not equal (or very close) to the one entered previously for Mass, you may want to change the value after analysis.

Installing the Sample Tube

These instructions are for installation on a single port; repeat for the number of ports being used.

Be sure to wear latex gloves when installing the sample tube onto the port. It is important that the sample tube and its components, as well as the sample and exhaust ports be clean and free of debris. Dust particles from quartz wool or from the insulator disk of previous analyses may adhere to the port and/or components, preventing a proper seal of the sample tube.

1. Using a lint-free swab moistened with IPA, wipe the interior rims of the sample and exhaust ports.
2. Use a lint-free tissue moistened with IPA and wipe the O-ring, ferrule, and connector nuts for the sample and exhaust tubes. Place on a lint-free tissue until installed (step 5).



It is very important that the sample and exhaust ports, as well as all components that contact the sample and exhaust ports, be clean. Therefore, it is recommended that steps 1 and 2 be repeated each time you install a sample onto the port.

3. Remove the stopper from the sample tube stem and the cap from the exhaust stem.
4. If using a hanging filler rod (recommended), hold the sample tube slightly tilted and carefully place the filler rod into the tube.
5. Assemble and install the sample and exhaust tube components as shown below.

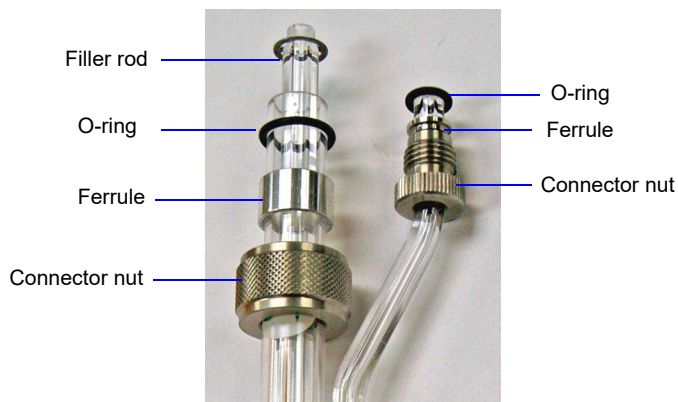

6. Align the sample and exhaust tube stems with their respective ports and carefully push the sample tube into the ports. Slide the connector nuts up the stems. Screw the nuts clockwise to secure the tube in place; hand-tighten both nuts.



7. Slide the insulator disk onto the sample tube. The insulator disk surrounds the sample tube when the furnace is raised, preventing heat loss and improving thermal stability.
8. Place the sample thermocouple between the stems of the sample and exhaust tube. Attach the thermocouple retaining clip to hold the thermocouple in place.

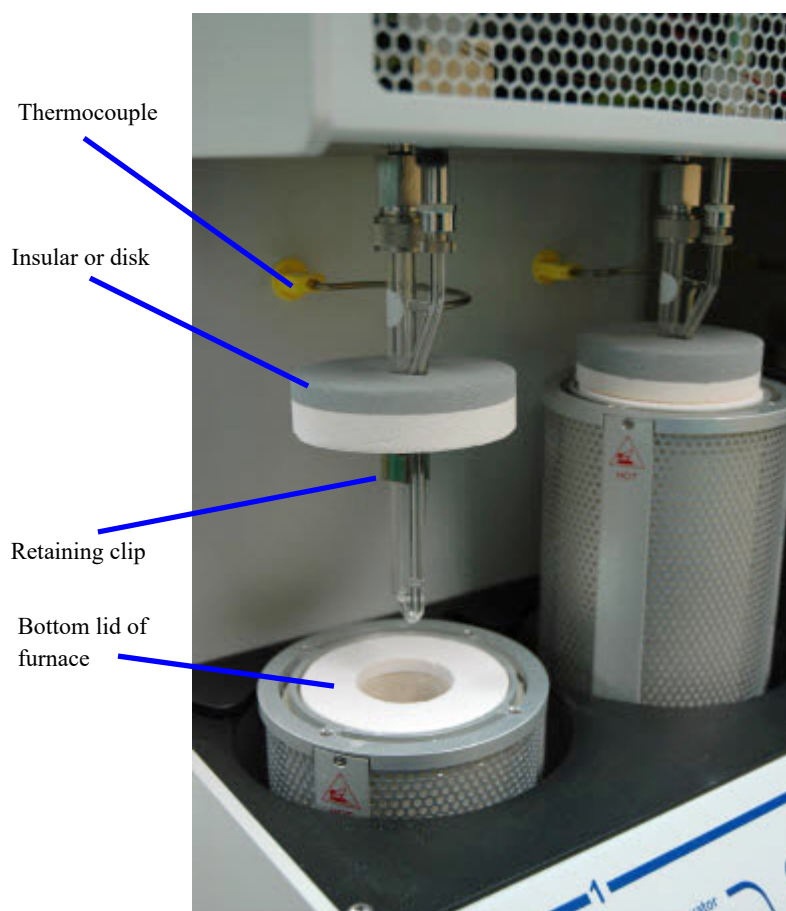

9. Check to ensure that the bottom lid is on the furnace.
10. Press the **Up** button on the port status pad to raise the furnace. Be sure the insulating disk seats properly on the top of the furnace.
11. Install the furnace shield.

Performing an Analysis

After the samples have been installed on the analysis ports, you may begin analysis. The ChemiSorb provides two types of analyses:

- **Sample Analysis:** use to perform up to six analyses
- **Sequence Analysis:** use to perform sequenced analyses using the same sample

Sample Analysis

See [Sample Analysis](#), page 6-3 for a detailed description of the fields on this dialog.

1. Select **Unit > Sample Analysis**; the Analysis dialog is displayed.

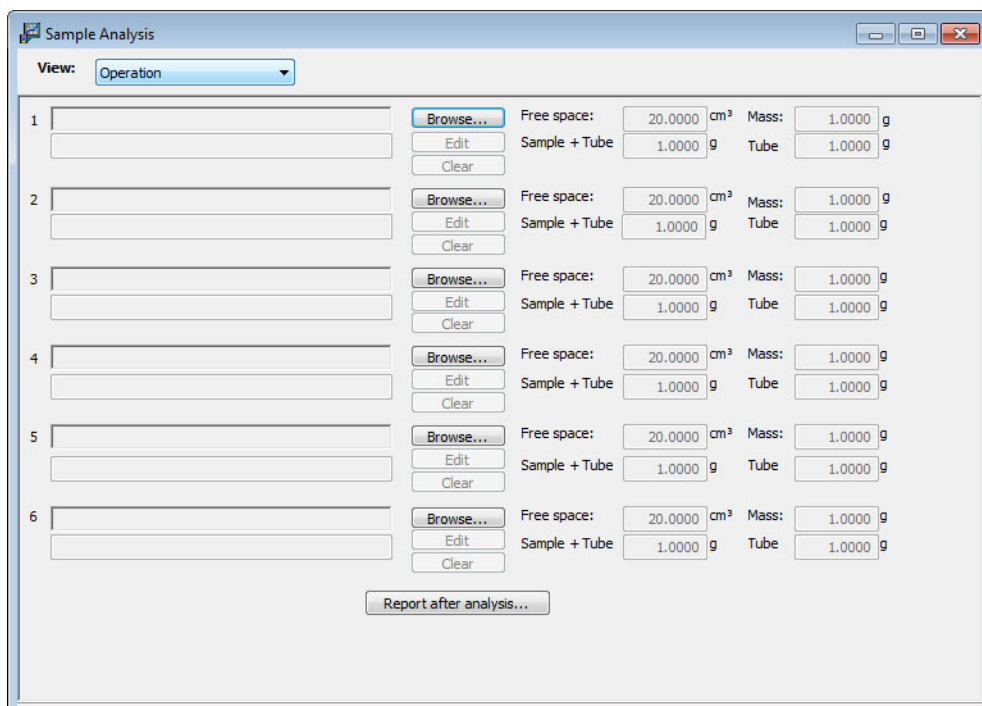

2. Click **Browse** at the right of the **Port 1** field to select a sample information file. The sample identification, free space, and sample mass contained in the sample information file are displayed.
3. Use the **Browse** button to the right of each port containing a sample to select a file. A compatibility check is performed to ensure that certain parameters match those of the sample chosen for port 1. If all parameters are not compatible, a dialog giving the incompatible areas is displayed. Use the **Edit** button to edit the file or select another file.
4. Select **Report after analysis** to have reports generated or isotherm data exported automatically when the analysis completes. Designate the destination if this option is deselected.

- Click **Start**; a second view of the analysis dialog prompting you to install insulating disks and safety shields is displayed.

Ensure that the tasks have been completed.

- Click **Next**; an analyzing view of the window is displayed so that you can view data as collected. A short delay is encountered before the port status changes from the Idle state.
- After the analysis is finished, remove the sample tube and dispose of the sample appropriately.

Sequence Analysis

See [Analysis Sequence](#), page 6-8 for a detailed description of the fields on this dialog.

- Select **Unit > Analysis Sequence**; the Sequence Analysis dialog is displayed.

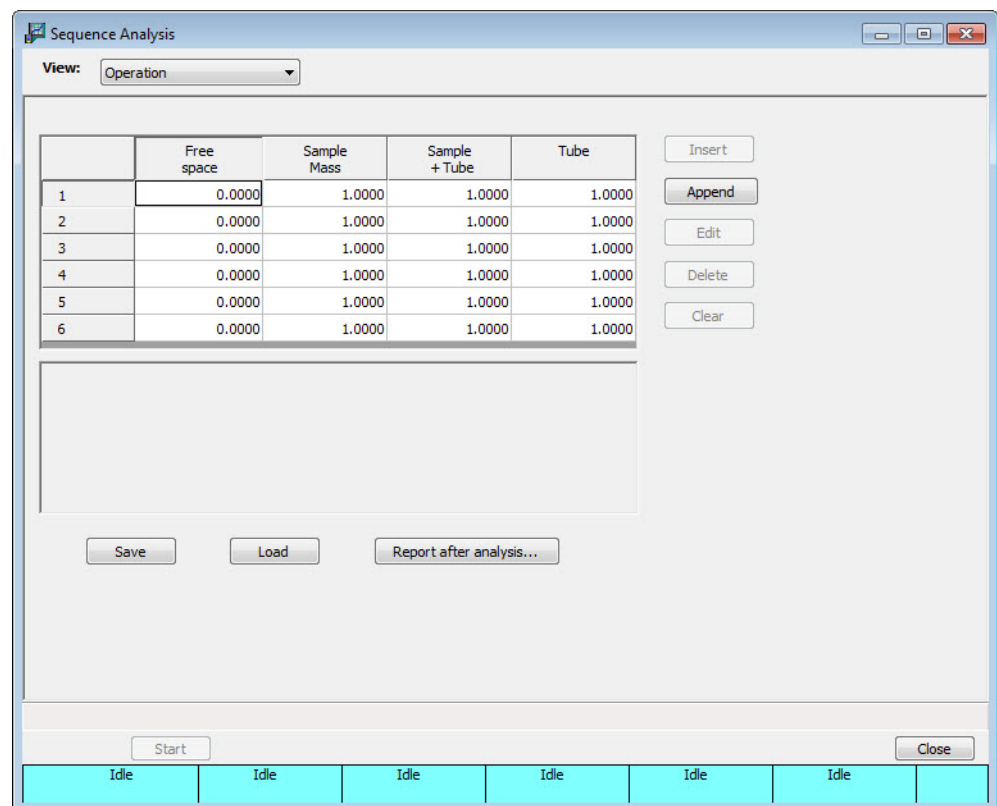

2. Click **Append** to assign sample files for the first sequence.

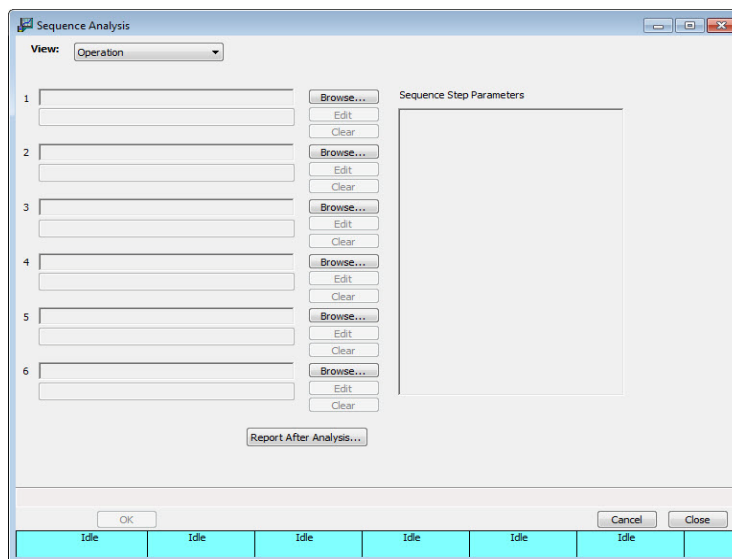

- a. Click **Browse**; the Open Sample Information dialog is displayed.
 - b. Select (or create) a file and click **Open** to return to the Sequence Analysis dialog.
 - c. Repeat steps (a) and (b) for relevant ports.
 - d. Use the **Edit** button to review or change file details.
 - e. Click **OK** to return to the Sequence Analysis dialog.
3. Repeat step 2 to assign sample files for the second sequence.
 4. Click **Start**; a view of the analysis dialog prompting you to install insulating disks and safety shields is displayed.

Ensure that the tasks have been completed.
 5. Click **Next**; an analyzing view of the window is displayed so that you can view data as collected. A short delay is encountered before the port status changes from the Idle state.
 6. After the analyses have finished, remove the sample tube and dispose of the sample appropriately.

Printing File Contents

Using the **Print** command on the File menu, you can print the contents of one or more sample or parameter files.

1. Select **File > Print >** (file type); a dialog similar to this one is displayed.

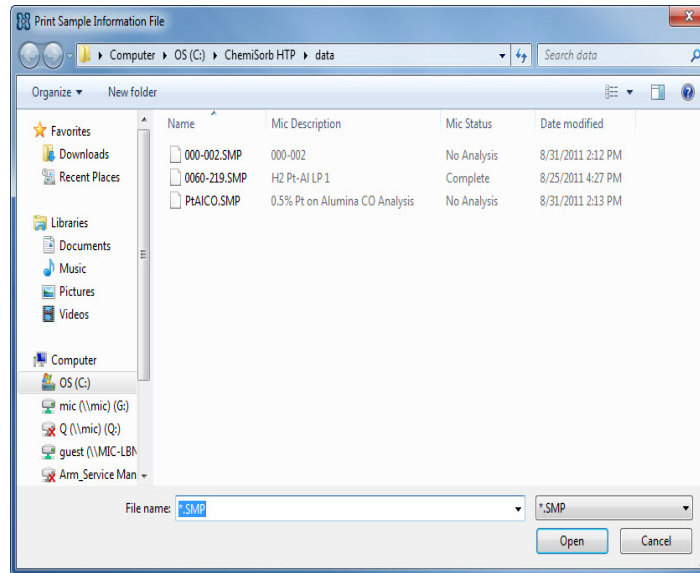

2. From the files window, select the file(s) to print. To print multiple files, hold down **Ctrl** while selecting the files.
3. Click **Open**. The **Report Settings** dialog is displayed.

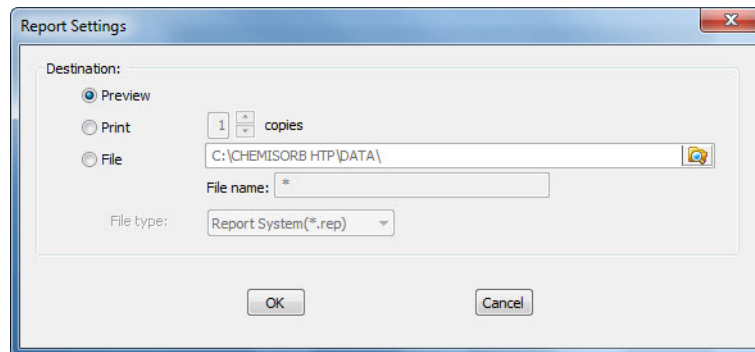

4. Select a destination for file output.
 - **Preview:** prints file contents to the screen.
 - **Print:** prints file contents to the default printer. Print up to 10 copies.
 - **File:** prints file contents to a file. Use the adjacent field to enter a name for the file, or accept the default.

- Click **OK**; the file is sent to the specified destination. The following example shows a sample information file printed to the screen.

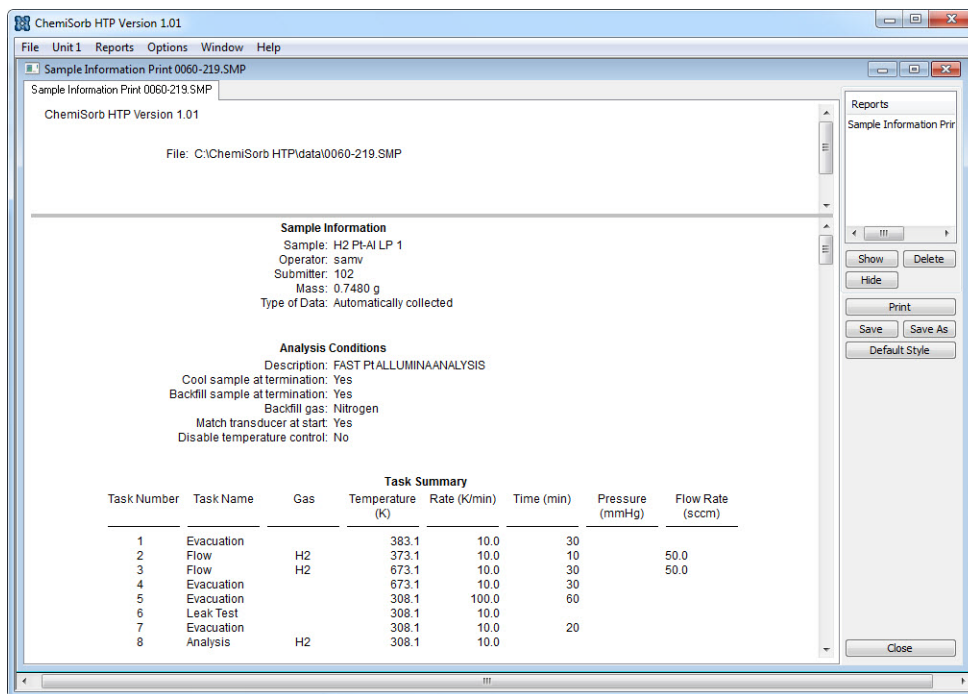

Listing File Statistics

You can generate a list of the following information on one or more sample or parameter files:

- File name
- Date the file was created (or last edited)
- Time the file was created (or last edited)
- File identification
- Status (sample files only)

1. Select **File > List> (file type)**; a dialog similar to this one is displayed.

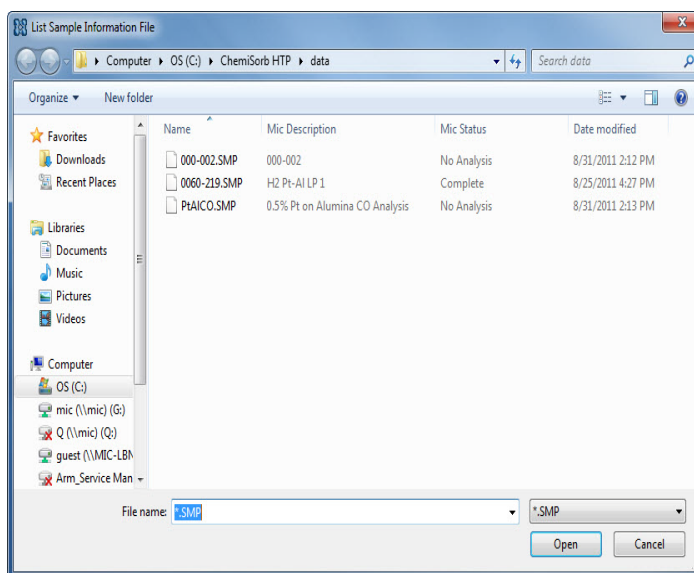

2. From the files window, select the file(s). To select multiple files, hold down **Ctrl** while selecting them. From the files window, select the file(s) to print. To print multiple files, hold down **Ctrl** while selecting the files.
3. Click **Open**. The **Report Settings** dialog is displayed.

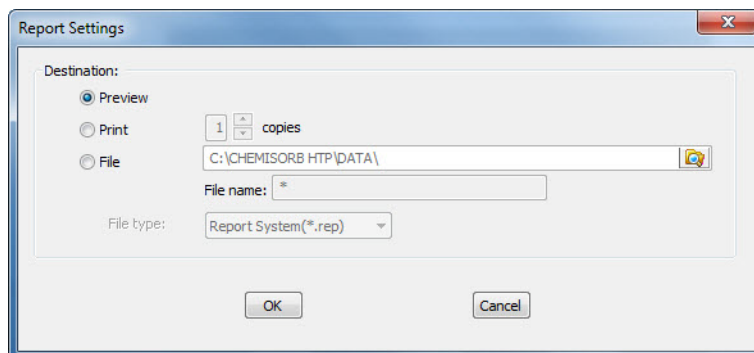

4. Select a destination for file output.

- **Preview:** generates file statistics to the screen.
 - **Print:** generates file statistics to the default printer. Print up to 10 copies.
 - **File:** generates file statistics to a file. Use the adjacent field to enter a name for the file, or accept the default. To select the type of file, use the **File type** drop-down list.
5. Click **OK**; file statistics are sent to the specified destination. The following example shows statistics for three sample information files printed to the screen.

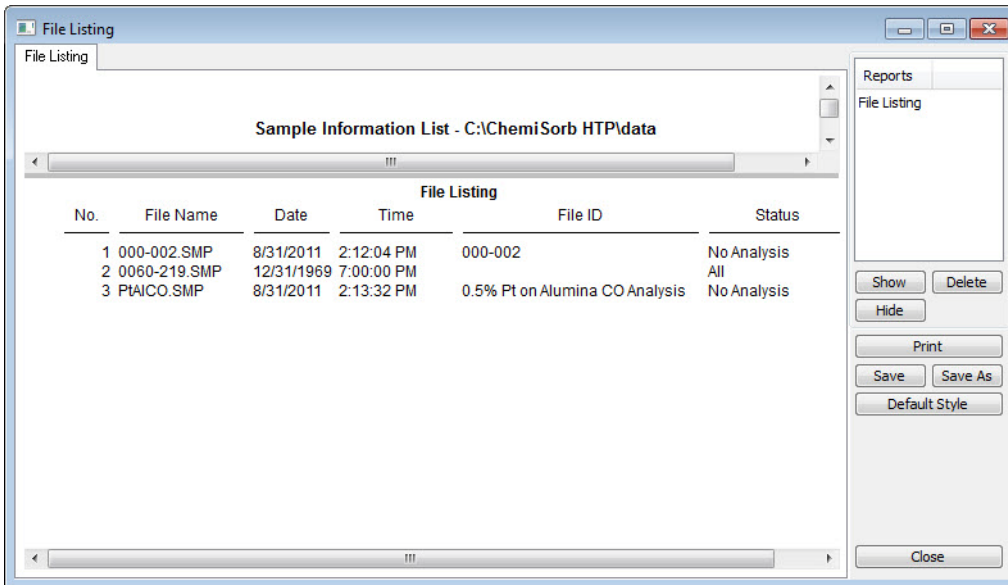

The screenshot shows a window titled "File Listing" with a "Reports" sidebar on the right. The main area displays a table titled "Sample Information List - C:\ChemiSorb HTP\data". The table has columns for No., File Name, Date, Time, File ID, and Status. The data rows are as follows:

No.	File Name	Date	Time	File ID	Status
1	000-002.SMP	8/31/2011	2:12:04 PM	000-002	No Analysis
2	0060-219.SMP	12/31/1969	7:00:00 PM		All
3	PIAICO.SMP	8/31/2011	2:13:32 PM	0.5% Pt on Alumina CO Analysis	No Analysis

The sidebar on the right contains a "Reports" section with "File Listing" selected, and buttons for Show, Delete, Hide, Print, Save, Save As, Default Style, and Close.

Exporting Isotherm Data

Use to copy the isotherm data in a sample information file and export it as an .xls, .rep. or .txt file.

1. Select **File > Export**; the Sample Information File Export dialog is displayed.

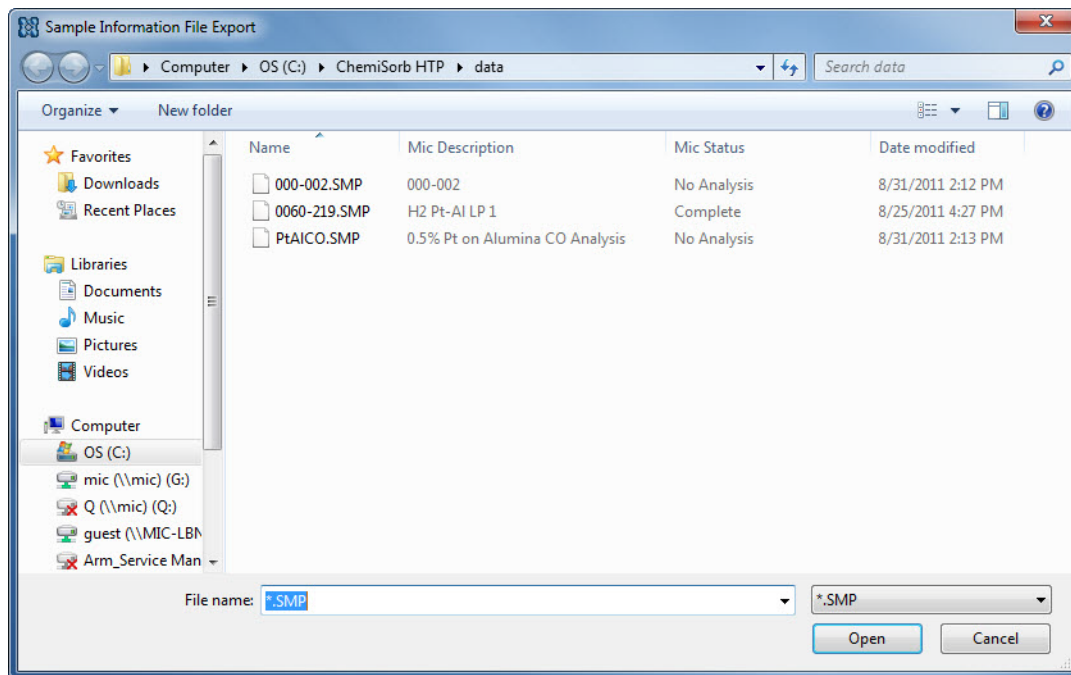

2. From the files window, select the file(s). To select multiple files, hold down **Ctrl** while selecting them.
3. Click **Open**. The **Report Settings** dialog is displayed.

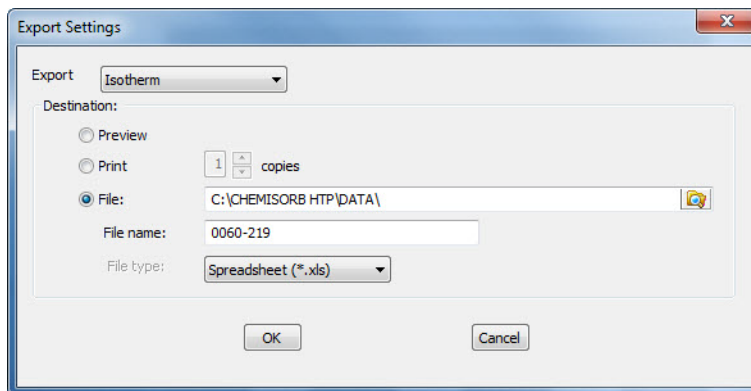

4. Select a destination for file output.
 - **Preview**: generates file statistics to the screen.
 - **Print**: generates file statistics to the default printer. Print up to 10 copies.

- **File:** generates file statistics to a file. Use the adjacent field to enter a name for the file, or accept the default. Use the The File type dropdown list to select either **Spreadsheet** or **ASCII text** as the output file type.
5. Click **OK**; the file is sent to the specified destination.

Generating Graph Overlays

Use the graph overlay function to overlay the same type of graph for multiple samples.

You must use the Advanced format for generating overlays. Select **Options > Options presentation > Advanced** to access the Advanced mode, or click the **Advanced** button on the Basic Sample Information dialog.

1. Select **File > Open > Sample Information** to display the Open Sample Information File dialog.
2. Select a sample on which to overlay graphs of other samples, then click **Open**; the Sample Information dialog is displayed.
3. Click the **Report Options** tab to display the Report Options dialog.

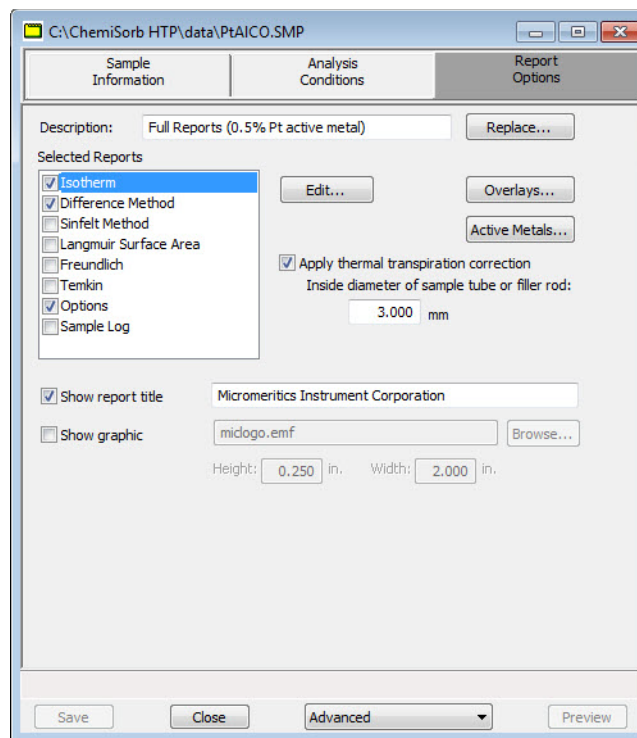

4. Select the report from the **Selected Reports** list; then click **Edit** to display report options. This example shows Isotherm Report Options.

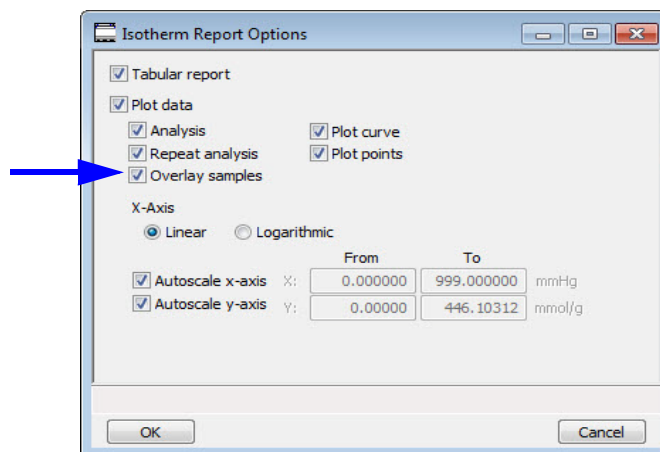

5. Select the **Overlay samples** check box, then click **OK** to return to the Report Options dialog.
6. Click **Overlays**; the Graph Overlays Samples dialog is displayed.

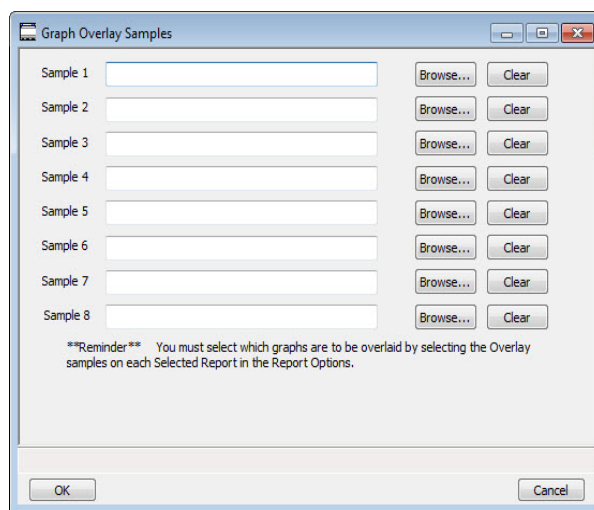

7. Click **Browse** to the right of the **Sample [n]** field; the Plot Overlay Sample Selection dialog is displayed.
8. Select the file containing the graph to overlay, then click **Open**. Select up to eight files.
9. After selecting the files, click **OK** to return to the Report Options dialog.
10. Click **Save** to save the selections. Overlays can be selected without saving.
11. Select **Reports > Start Report**; the Start Report dialog with the name of the edited file highlighted is displayed.

12. Click **Report**; the Select Reports dialog is displayed.
13. Ensure that the report is selected, then click **OK**.

4. SOFTWARE AND SETUP MODIFICATIONS

This chapter provides instructions for:

- Installing the software
- Using the Setup Program for other functions

You can also install the analysis program for offline data manipulation on a computer other than the one controlling the analyzer. This allows:

- create or edit sample and parameter files
- generate reports on completed sample files

Review the Micromeritics PROGRAM License Agreement for restrictions on the use of another copy of the analysis program.

Installing the Software

1. Insert the installation CD into the CD-ROM drive. The program automatically starts the installation.

If the installation does not immediately start, perform the following steps:

- a.) Select **Start** from the Status bar, then **Run** from the Start menu.
- b.) Enter the name of the drive designator, followed by **setup**. For example, if the CD-ROM drive is drive **e**, enter: **e:setup**
- c.) Click **OK**. The Welcome screen displays.

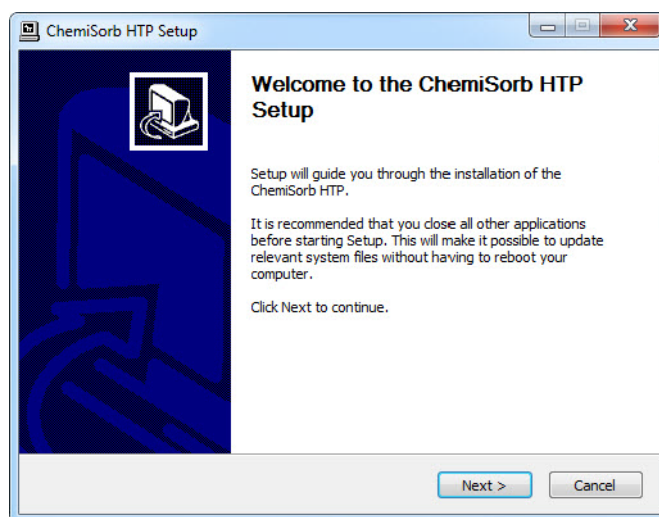

2. Click **Next** to continue the setup process.

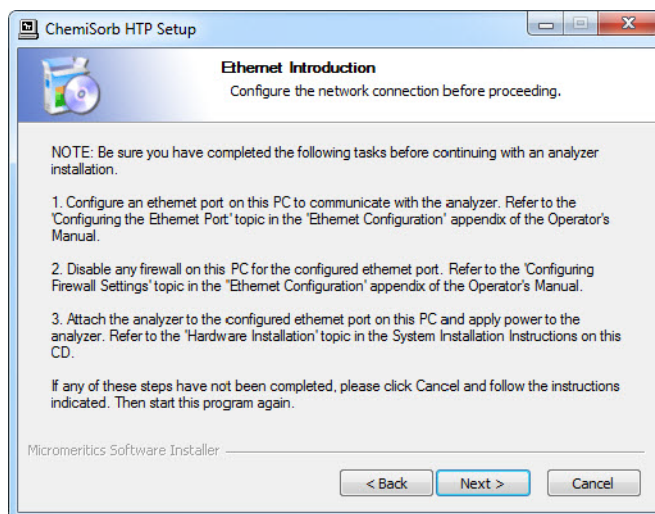

Make sure the steps described on this screen are complete, then click **Next**.

3. On the **Choose Users** screen, select either of the following:
 - **Install for anyone using this computer** - anyone who logs on to this computer will have access to the analyzer program.
 - **Install just for me** - only the person logged onto the computer at the time of installation will have access to the analyzer program.

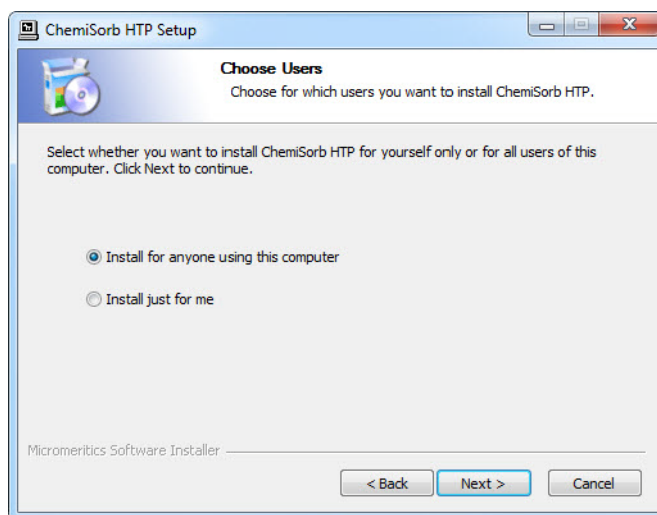

4. Click **Next**.
5. On the **Choose Install Location** screen, verify that enough disk space is available to continue the installation. If not, click **Cancel** and free up enough disk space. If the disk space is OK, click **Browse** to change the default installation location then click **Next**. Or click **Next** to accept the default directory of C:\ChemiSorb HTP.

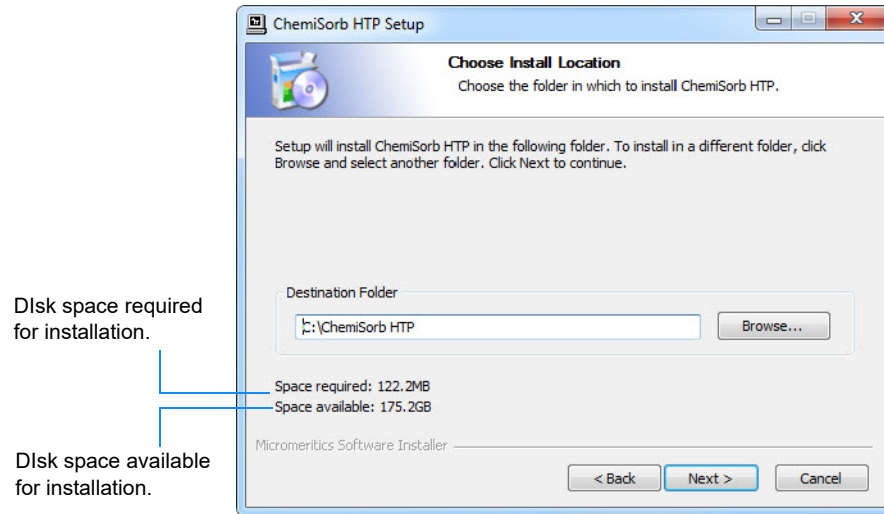

6. On the **Choose Start Menu Folder** screen, select a folder for the program shortcut.
 - Click **Install** to accept the default (Micromeritics), or
 - Select another folder from the list and click **Install**, or
 - Enter a new folder name in the text box, then click **Install**

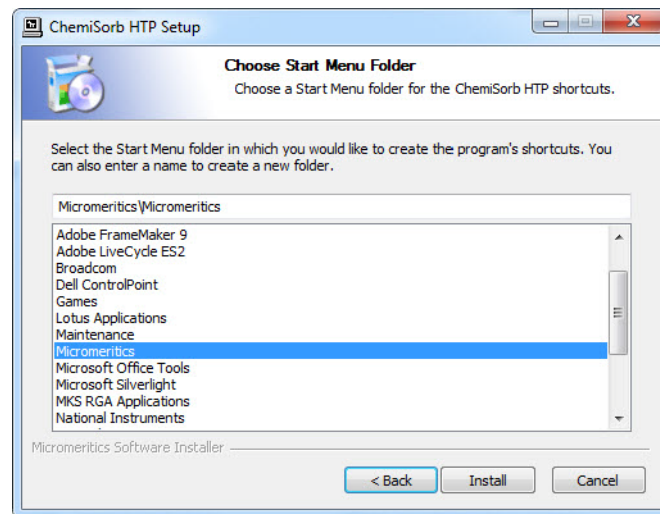

7. The installation continues. When complete, the screen title changes to **Installation Complete**. Click **Next** on the next three screens.
8. The **Installation Complete** screen displays the installed version and indicates the installation has finished. Click **Finish** to complete the process and close the screen.
9. Remove the CD from the CD-ROM drive and store in a safe place.

Using the Setup Program for Other Functions

After initial installation of the analysis program, the application setup program can be used to:

- install software upgrades, page 4-5
- add an analyzer, page 4-6
- move an analyzer from one computer to another computer, page 4-8
- change the analyzer setup (port configuration), page 4-13
- remove an analyzer from the computer, page 4-12
- reinstall calibration files, page 4-15
- uninstall the analysis program, page 4-16

Starting the Setup Program

To start the setup program:

1. Ensure that the analysis program is not operating and the analyzer is idle.
1. Ensure that the analysis program is not operating and the analyzer is idle.
2. Insert the CD into your CD-ROM drive.
3. The Setup program starts automatically.

If the program does not start automatically, enter the drive designator of the CD-ROM drive, followed by **setup**. For example: **e:setup**

Alternatively, you can click **Browse**, navigate to the CD-ROM drive, and select **setup.exe**.

4. The Welcome window is displayed. Click **Next**.

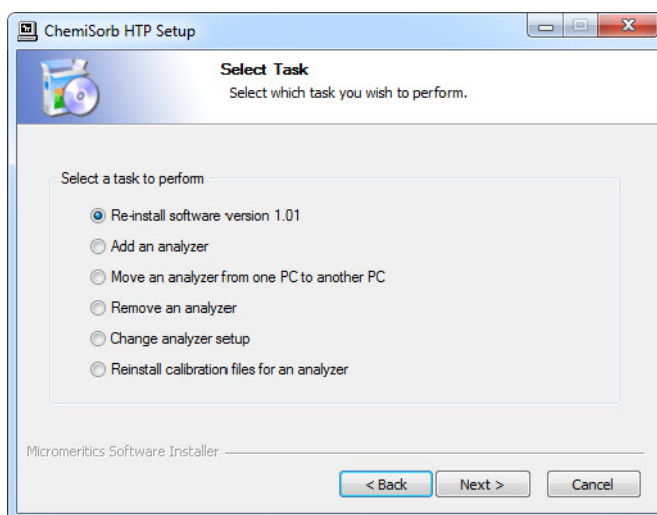

5. Select the task you want to perform, then click **Next**.

Installing Software Updates or Reverting to a Previous Version

When you install a software upgrade, existing data files are not overwritten. There are three types of subsequent installations; the software version controlled by the setup program is:

- a later version than the version installed on the computer
- the same version as the version installed on the computer
- an earlier version than the version installed on the computer

The setup program automatically detects which type of installation applies and customizes the selection in the Setup dialog accordingly.

1. Start the Setup Program (see [Starting the Setup Program](#), page 4-4).
2. Select the software option (only the applicable option will display); it will be one of the following:
 - Upgrade software to version (number) from version (number)
 - Reinstall software version (number)
 - Downgrade software to version (number) from version (number)



If the option *Downgrade software to version (previous number)* displays, contact your Micromeritics representative before proceeding. Reverting to a previous version can damage existing sample files.

3. Click **Start File Installation**; the application installs the software and displays the setup Welcome dialog.

Adding an Analyzer

An ethernet switch is required when connecting multiple analyzers. After connecting the ethernet switch, continue with the software section.

Ethernet Switch

An Ethernet switch with an Ethernet cable is required when installing multiple analyzers.

1. Connect the power cord of the Ethernet switch to an appropriate power outlet.
2. Disconnect the ethernet cable of the current analyzer from the computer; do not disconnect it from the analyzer.
3. Connect one end of the Ethernet cable to the Ethernet switch and the other end to the computer.
4. Connect the ethernet cable of the current analyzer to a numbered port on the Ethernet switch (do not use the uplink port).
5. Connect one end of the Ethernet cable (for the analyzer you are adding) to the connector labeled **Ethernet** on the rear panel of the analyzer and the other end to a numbered port on the Ethernet switch.

The finished configuration should look similar to the following illustration.

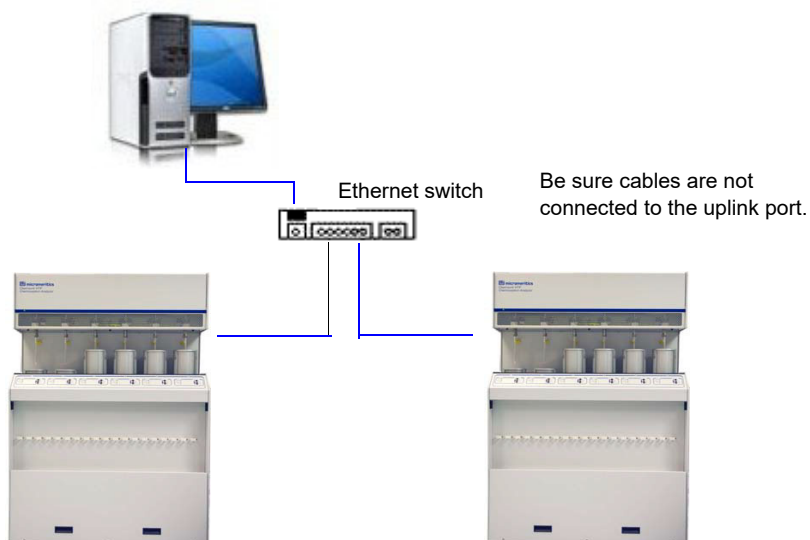

6. Turn on the analyzer that was added. Also ensure that the computer and current analyzer are on.

Software

1. Start the Setup Program (see [Starting the Setup Program](#), page 4-4).
2. Select **Add an analyzer**, click **Next**; the Set up analyzer being added dialog is displayed.

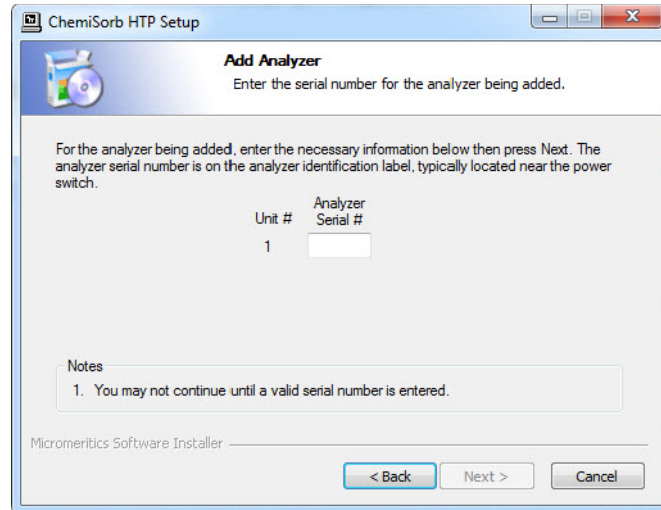

You may see the Ethernet Introduction screen. This information is not applicable since you are connecting to an ethernet switch which is connected to a port that has been configured. Click OK to close the screen and proceed.

3. Enter the serial number of the analyzer being added.
4. Click **Next**. The following screen is displayed.

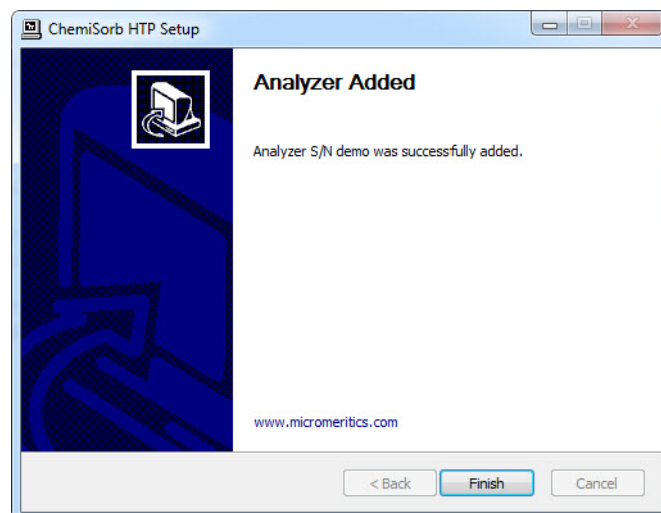

5. Click **Finish**.

Moving an Analyzer from One Computer to Another Computer

Use the instructions in this section to move a configured analyzer (along with its status, calibration, and log file) from one computer (**Source PC**) to a different computer (**Destination PC**). This operation does not move sample or parameter files. Use a file management program such as Explorer or a backup/restore utility to move these types of files.

1. Start the application setup program on the **Source** computer.
2. In the Setup dialog, select **Move an analyzer from one PC to another PC**, then click **Next**; the Move analyzer operation dialog is displayed.

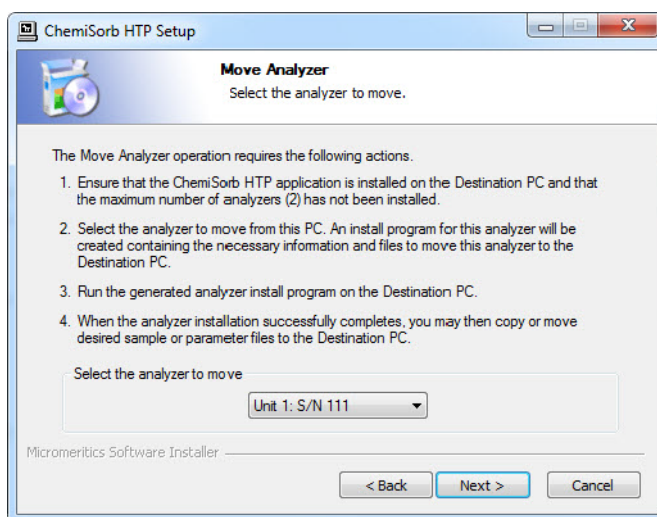

3. From the drop-down list, select the analyzer that is to be moved from this computer.
4. Click **Next**; the Move Analyzer dialog is displayed.

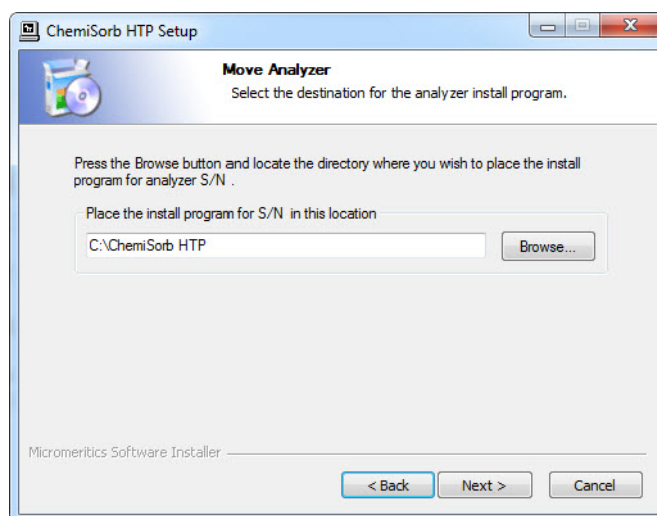

5. Click **Browse** to select a location for the program that will be created to install the software on another computer.

6. Click **Next**; the files are moved to the install program and the following screen is displayed.

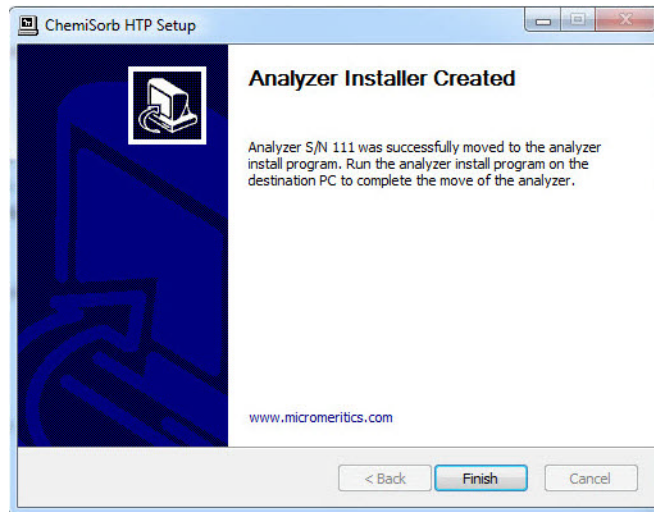

7. Click **Finish**.
8. Remove the CD from the CD-ROM drive.
9. Disconnect the ethernet cable from the **Source** computer and reconnect it to the configured ethernet port on the **Destination** computer.

If you are moving this analyzer to a computer that already has an analyzer attached, an ethernet switch is required (see [Ethernet Switch](#), page 4-6 for instructions on attaching an ethernet switch).

10. If you saved the installation program to a network directory (Step 4), open the program. For example, **Analyzer SN 111 Installer.exe**.

If you saved the directory to a local directory, copy the **Installer.exe** file to a media device such as a USB stick, install it on the destination computer, then open the program.

11. The Welcome dialog is displayed, click **Next**.

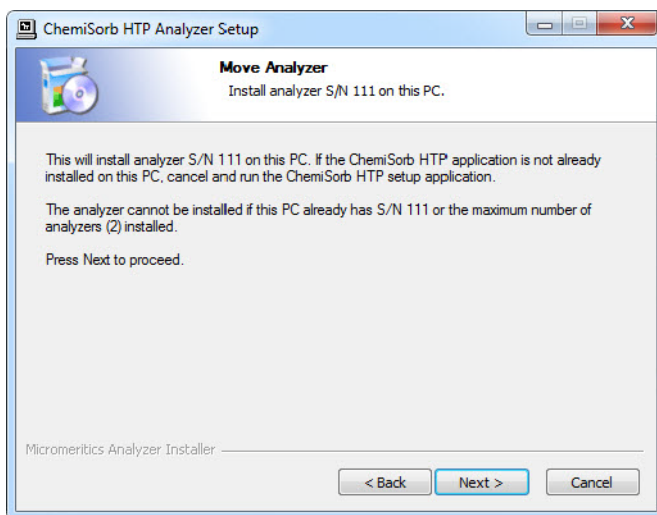

12. Click **Next**; the Ethernet Introduction dialog will be displayed if the network connection was not previously configured.

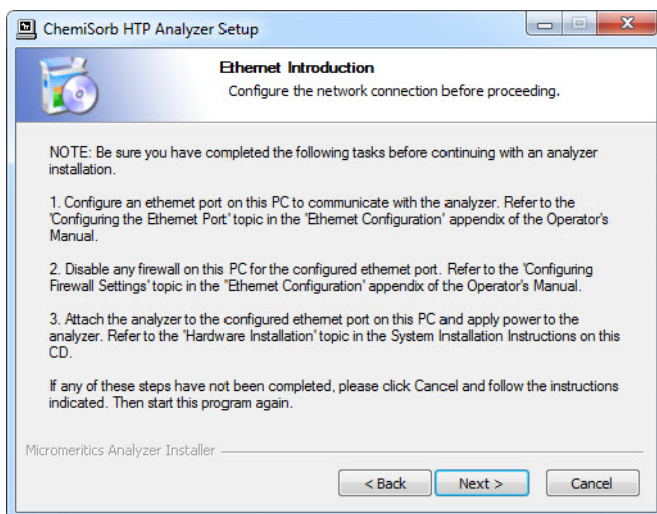

13. Make sure the tasks described on the screen are completed, then click **Next** to display the Analyzer Installed dialog.

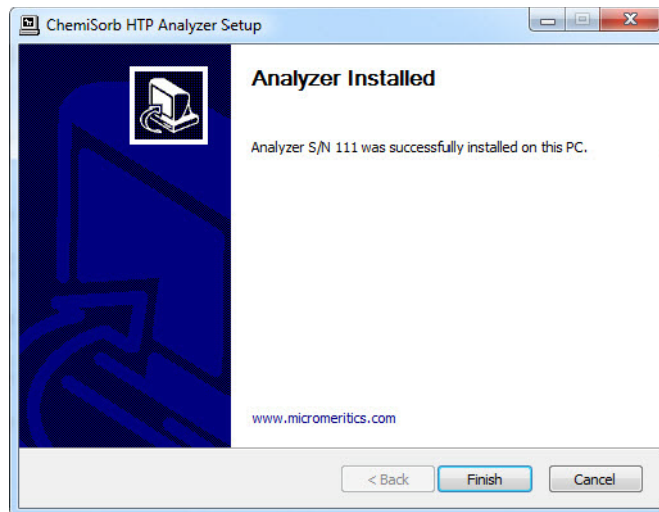

14. Click **Finish**.



Sample and parameter files are not copied and moved with the analyzer. Use a file management program such as Explorer or a backup/restore utility to move these files.

Removing an Analyzer

You can remove an analyzer from the computer as follows.

1. Start the Setup Program (see [Starting the Setup Program](#), page 4-4).
2. Select **Remove an analyzer**, then click **Next**; the Remove an analyzer dialog is displayed.

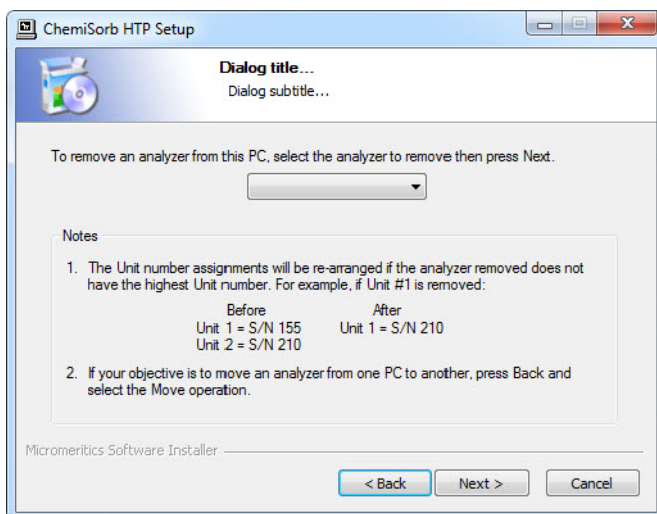

3. From the drop-down list, select the serial number of the analyzer you want to remove.



This operation removes the selected instrument from the list of attached instruments. It does not remove calibration and status files associated with the analyzer, nor does it remove sample and parameter data files.

4. Click **Next**; the following screen is displayed.

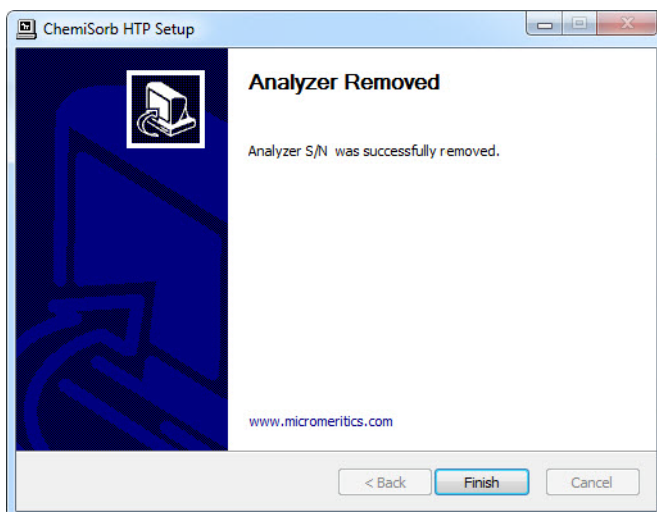

5. Click **Finish**.

Changing the Analyzer Setup Configuration

Use to change the ethernet port being used by the analyzer(s). For example if the current ethernet port malfunctions, use to move the analyzer to another ethernet port.

Ensure the ethernet port you are switching to has been configured.

1. Start the Setup Program (see [Starting the Setup Program](#), page 4-4).
2. Select **Change analyzer setup**, then click **Next**; the Ethernet Introduction screen is displayed. This screen outlines the steps that should be completed to configure the ethernet port to which the analyzer will be connected.

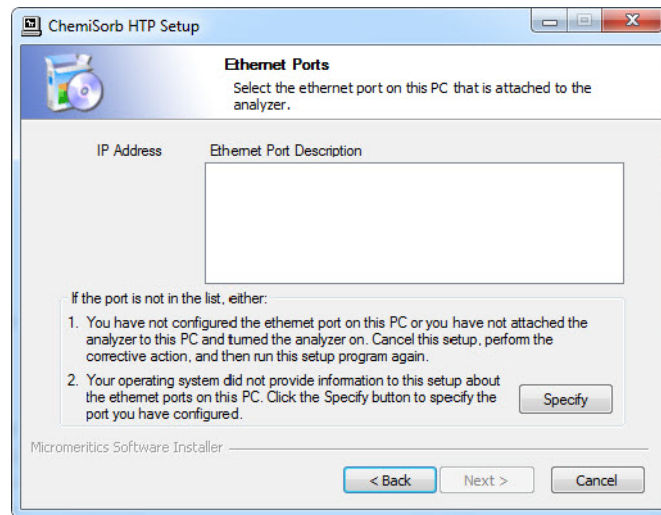

- Select the ethernet port from the list of available port, click **Next**, and proceed to Step 4, or
- If an Ethernet configuration has not been detected, click **Specify**.

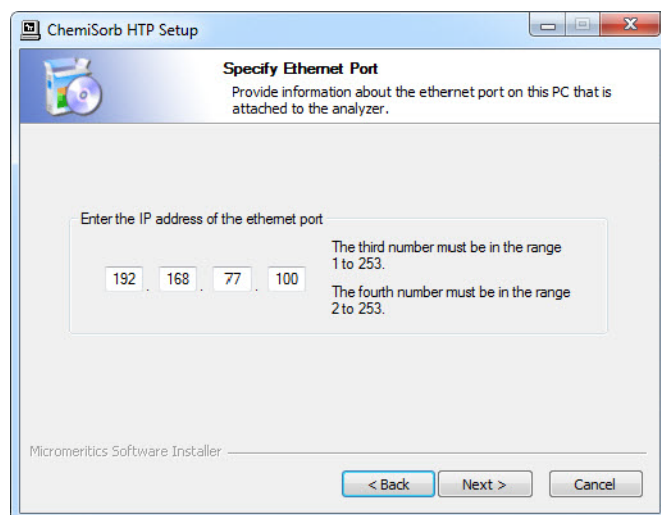

3. Enter the Ethernet port, then click **Next**.
4. The Analyzer Configuration Updated dialog is displayed.

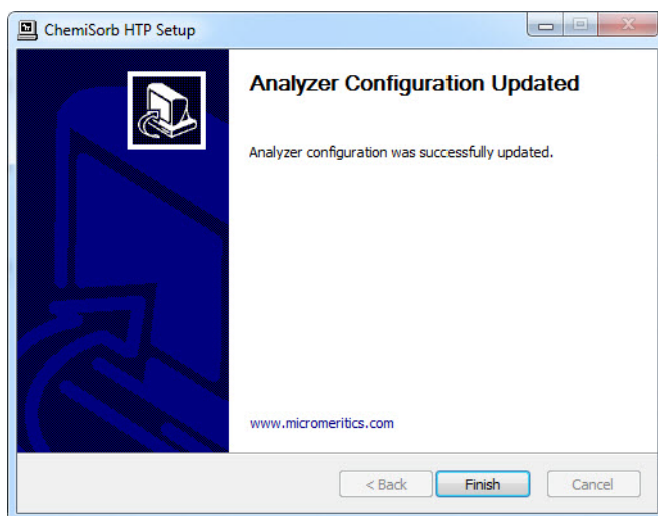

5. Click **Finish**.

Reinstalling Calibration Files

Calibration files specific to the analyzer are contained on the original program CD; they are not contained on an update CD. It is important that you store your original program CD in a safe location. CDs containing calibration files will always end with a suffix of **99**. Update CDs end with a suffix of **00**.

Reinstall calibration files as follows:

1. Start the Setup Program (see [Starting the Setup Program](#), page 4-4).
2. Select **Re-install calibration files for an analyzer**, then click **Next**:

If ...	Then ...
you have only one analyzer installed	the calibration files are installed and the Finish screen is displayed.
you have multiple analyzers installed, select the analyzer from the list.	select the appropriate analyzer, then click Next ; the calibration files are installed and the Finish screen is displayed.

Uninstalling the Analysis Program

When you uninstall the ChemiSorb program, the application removes the analysis program, status files, analyzer setup files, and resulting empty directories. It does not remove data files. Perform the following steps to uninstall the program:

1. Locate the **Uninstall.exe** file in the directory where the DataMaster files are located.
2. Double click the **Uninstall.exe** file and click **Uninstall** to start the uninstall process.
3. Select **Uninstall**, then click **Next**; the Uninstall dialog is displayed.

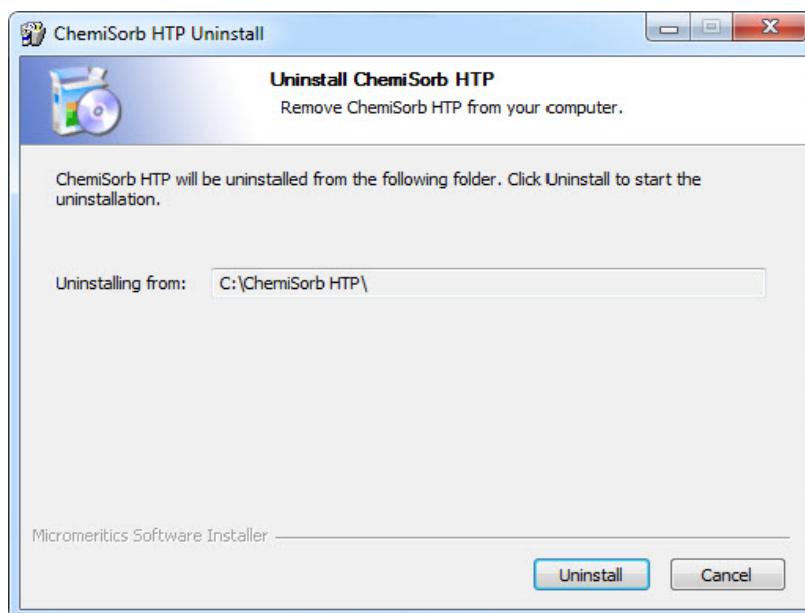

4. The uninstall process continues and the **Uninstallation Complete** screen displays. Click **Next** to finish the process.

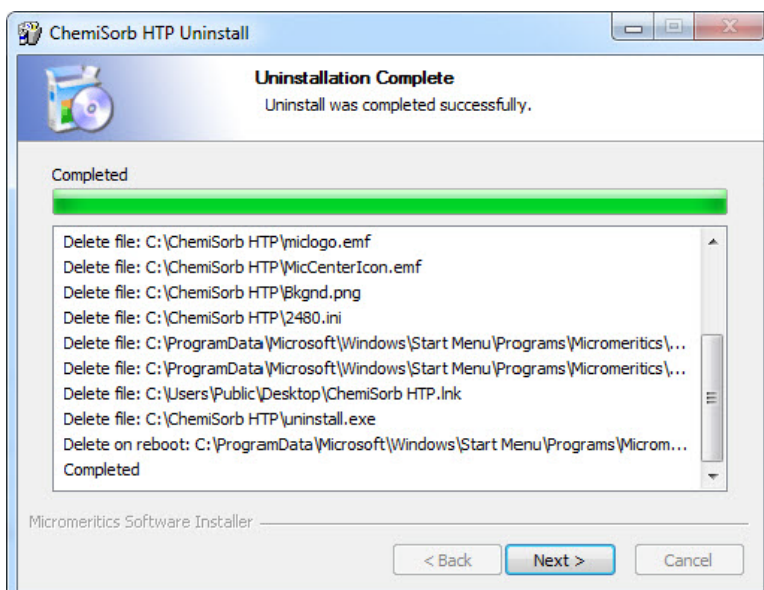

5. The computer must be rebooted to complete the uninstallation process. Select:
 - **Reboot now** - to immediately restart the computer, then click **Finish**, or
 - **I want to manually reboot later** - to restart the computer later, then click **Finish**.

5. FILE MENU

This chapter describes the file maintenance options used to create, edit, print, list, and export sample and parameter files.

Description

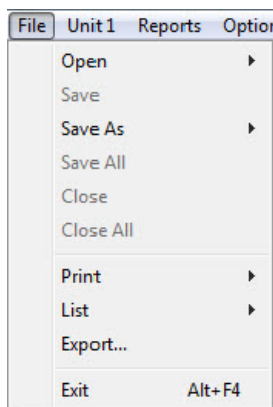

Listed below are brief descriptions of the commands on the File menu. Detailed descriptions follow this section.

Open	Use to create a new sample or parameter file, or open an existing one. Page 5-3 .
Save	Saves the file in the active window. Page 5-44 .
Save As	Use to save the file in the active window under a new name. It can also be used to save a subset of a sample file as a parameter set. Page 5-44 .
Save All	Saves all open files. Page 5-44 .
Close	Closes the file in the active window. Page 5-44 .
Close All	Closes all open files. Page 5-44 .
Print	Prints the contents of one or more files. Page 5-45 .

List	Generates a list of certain information for specified sample or parameter files. Page 5-47 .
Export	Exports isotherm data from a sample information file in the selected format. Page 5-48 .
Exit	Exits the ChemiSorb program. Page 5-51 .

Open

Click **Open** to create a new or open an existing sample or parameter file.

Select the file type; a dialog similar to the following is displayed:

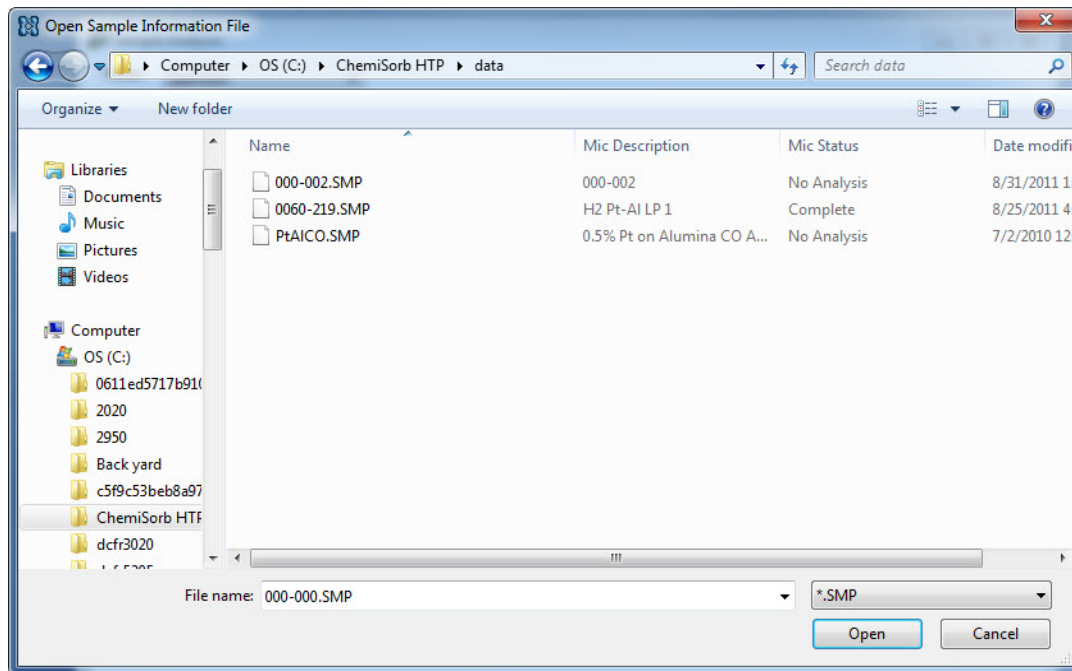

Files list

This list contains the files located in the current directory.

File name

For **sample information** files, this field contains the next sequenced file name (as specified in sample defaults) generated by the system.

For **parameter files**, the name includes the wild card (*) and the default extension as follows:

*.ANC for analysis conditions

*.RPO for report options

If you are creating a file, enter a name in the **File name** field.

If you are opening an existing file, select the file from the list, then click **Open**. Use the **Ctrl** key to select multiple files; hold down the key while selecting the files.

Sample Information

A Sample information file contains data that guide the analysis; it consists of:

- sample information
- analysis conditions
- report options
- collected (after analysis) or manually entered data

Parts of the sample information file can also exist as standalone parameter files. Having these files exist independently allows multiple use. For example, if using the same analysis conditions for many analyses, create an analysis conditions file containing the conditions. When creating a sample file, select that file for the analysis conditions; the values are copied into the sample file. After it becomes part of the new sample file, it can be edited. The file from which the values were copied remains intact and ready for the next use.

Sample information files can be created and presented in the Advanced, Basic, or Restricted format.

- **Advanced**
Presents all parts of the sample information file in a tabbed dialog. Each tab opens its associated dialog, allowing edits to be made.
- **Basic**
Presents all parts of the sample information file as a single dialog. Use to create a sample information file using predefined parameter files. The user can switch to Advanced format.
- **Restricted**
Identical to the Basic format except that you cannot switch to the Advanced format for editing. Certain functions also are disabled.

Advanced Format

The Advanced format of a sample information file displays all parts of the sample file in a tabbed dialog. Quick-access tabs to move among the parameters.

See [Advanced Format](#), page 3-9 for step-by-step instructions for creating a Basic sample information file.

The screenshot shows a software window titled "C:\ChemiSorb HTP\data\000-002.SMP" with three tabs: "Sample Information", "Analysis Conditions", and "Report Options". The "Sample Information" tab is active and contains the following fields and controls:

- Sample: 000-002
- Operator: [empty]
- Submitter: [empty]
- Bar Code: [empty]
- Mass section with two radio buttons: "Enter" (selected) and "Calculate".
- Under "Enter": Sample Mass: 0.5000 g
- Under "Calculate": Sample + tube: 1.5000 g, Empty tube: 1.0000 g, and a third field with 0.5000 g.
- Type of Data section with two radio buttons: "Automatically collected" (selected) and "Manually entered".
- Comments: [empty text area]
- Buttons: "Replace all...", "Add log entry...", "Save", "Close", "Advanced" (dropdown), and "Preview".

Sample

Displays the default file description for a new file or the description of the file you are opening.

Enter a new description or edit the existing one.

Operator Submitter

Displays the operator and submitter names in the current sample file.

If this is a new file, these fields contain the names specified in **Sample Defaults**.

Enter a different name or edit the current one.

Operator Submitter <i>(continued)</i>	These fields can be omitted or changed to display a different label. See Sample Defaults , page 8-6.
Bar Code	<p>Use to enter bar code information. If bar code information is not used, use this field to enter additional information about the sample; for example, enter the lot number of the sample. This field can be omitted in Sample Defaults if it is not needed.</p> <p>This field, as well as the Operator and Submitter fields, will accept data from a bar code reader.</p>
Mass	<p>Use to enter a sample mass or have the mass calculated automatically.</p> <p>Enter the sample's mass. If using a Sample Data Worksheet, enter the value recorded as Mass of Sample After Degas.</p> <p>The value entered for Mass is used in report calculations; therefore, it should be exact. To ensure accuracy, reweigh the sample after analysis. If the value is not equal (or very close) to the one entered previously for Mass, change the value after analysis.</p>
Enter	Enables the Sample Mass field.
Calculate	<p>Enables the Empty tube and Sample + tube fields. These values are used to calculate the mass of the sample,</p> $Mass_{sample} = Mass_{sample + tube} - Mass_{tube}$ <p>See to Determining the Sample Mass, page 3-15.</p>
Type of Data	Displays the type of data for the current sample file. If this is a new file, select Automatically collected to have data collected automatically, or Manually entered if you plan to enter data collected from another source. An Entered tab is added to the sample information dialog for entering the values.
Comments	Use to enter pertinent information about the sample or analysis. The information entered is displayed in the report header.

Add Log Entry

Displays the Add Log Entry dialog.

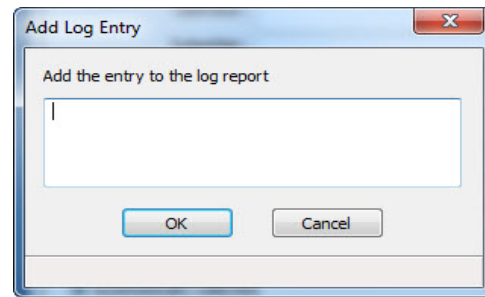

Use this dialog to enter information pertinent to the sample file. Any information you enter here is printed as part of the sample log report. Click the button again to enter multiple entries.

Replace All

Use to replace the values of all parameters of the current file with those from an existing one. Edit the values after they have been copied into the current file; editing the current files will not affect the file from which they were copied.

Save

Saves all parameters of the current file; the dialog remains open.

Close

Closes the dialog. If the dialog contains changes that have not been saved, a prompt displays to save them before the dialog closes.

Advanced

Use to switch the sample editor to the Basic format.

Preview

Prints the reports selected on the Reports Options dialog.

This option is disabled for sample files that have not been used in an analysis.

Basic Format

The Basic format displays all parts (parameters) of the file on a single dialog. With this format, you can quickly create a sample information file using predefined parameter files. This format also allows the switching to the Advanced format to view or edit parameters.

See [Basic and Restricted Formats](#), page 3-10 for step-by-step instructions for creating a Basic sample information file.

The screenshot shows a dialog box titled "C:\ChemiSorb HTP\data\000-002.SMP". It contains the following fields and controls:

- Sample: 000-002
- Operator: (empty)
- Mass section with two radio buttons: Enter and Calculate.
- Sample Mass: 0.5000 g
- Sample + tube: 1.5000 g
- Empty tube: 1.0000 g
- 0.5000 g (input field)
- Analysis Conditions: (dropdown menu)
- Report Options: Report Options (dropdown menu)
- Buttons: Replace all..., Add log entry...
- Bottom bar: Save, Close, Basic (dropdown menu), Preview

Sample

Displays the default file description (new files) or the description in the file you are opening. If a dollar (\$) symbol was included in sample defaults, the next sequenced file number will also display (as shown in the above example).

You may enter a new description or edit the existing one.

Operator	<p>Displays the operator name in the current sample file.</p> <p>If this is a new file, this field contains the name specified in Sample Defaults.</p> <p>Enter a different name or edit the current one.</p> <p>This field can be omitted or changed to display a different label. See Sample Defaults, page 8-6.</p>
Mass	<p>Use to enter a sample mass or have the mass calculated automatically.</p>
Enter	<p>Enables the Sample Mass field.</p>
Calculate	<p>Enables the Empty tube and Sample + tube fields. These values are used to calculate the mass of the sample.</p> $Mass_{sample} = Mass_{sample+tube} - Mass_{tube}$ <p>See Determining the Sample Mass, page 3-15.</p>
Analysis Conditions Report Options	<p>Each parameter field contains the description of the current parameter file.</p> <p>If this is a new sample file, these fields contain the descriptions of the files chosen as the defaults.</p> <p>Click the down arrow to the right of each field to select a different file. File parameters can be viewed or edited by switching to the Advanced format.</p>

Add Log Entry

Displays the Add Log Entry dialog.

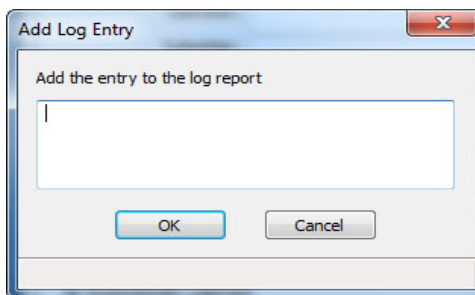

Use to enter information pertinent to the sample file. Any information entered is entered into the sample log report. Click the button again for multiple entries.

Replace all

Click to replace all parameters of the current file with those copied from an existing one.

Save

Saves all parameters of the current file; the dialog remains open.

Close

Closes the dialog.

Basic

Use to switch the sample editor to the Advanced format.

Preview

Prints the reports selected on the Reports Options dialog.

This option is disabled for sample files that have not been used in an analysis.

Restricted Format

A third format is provided to control access to some portions of the sample information file. The Restricted format displays in the same manner as the Basic presentation format.

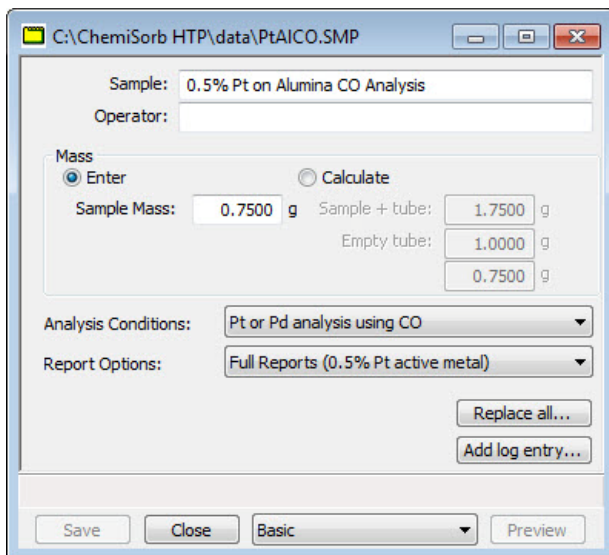

This dialog is identical to the Basic dialog except that it does not allow switching to the Advanced format.

The fields on this dialog are identical to the ones on the Basic Information dialog except that the user cannot switch to the Advanced format. This format is also password-protected, preventing the operator from making changes to file parameters. See [Restricted](#), page 8-5.

Restricted presentation is ideal for laboratories in which standard analysis procedures are established by a lab manager, while one or more lab technicians actually perform the analyses. The lab manager can create independent parameter files containing standard sets of operating conditions, then the operator can use Restricted mode for daily operations, selecting the standard parameter files from the drop-down lists.

Analysis Conditions

Analysis conditions specify the data, or tasks, used to guide the analysis. This section describes the analysis conditions options available on the ChemiSorb system. An analysis conditions file may exist as an independent file or as part of the sample information file.

See [Analysis Conditions](#), page 3-6 for step-by-step instructions on creating analysis conditions files.

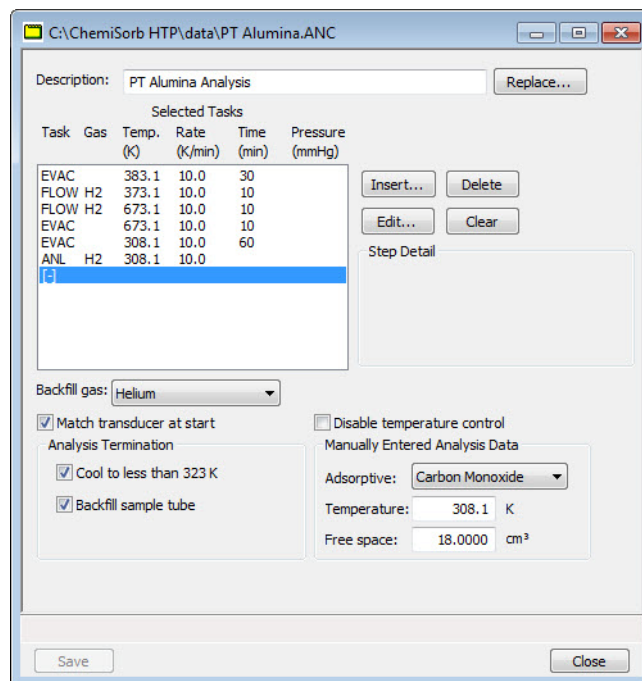

Description

Contains the description of the current Analysis conditions file.

If this is a new file, this field contains the identification specified in Sample Defaults. You can edit this name.

Replace

Click to replace the values of the current file with those of another. Values in the new file may be edited.

Selected Tasks

This window lists the tasks selected for the analysis. Tasks are inserted using the **Insert** button.

You can include up to 20 tasks.

Insert

Displays the Select a Task dialog enabling you to insert analysis tasks in the Selected Task list.

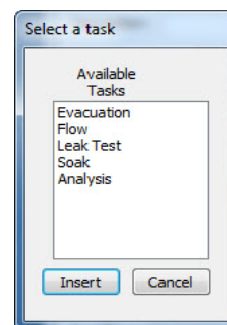

An analysis is defined by the tasks from which it is comprised. Tasks are executed in the order in which they are sequenced. You do not have to include all the tasks in an experiment.

Only one Analysis task can be inserted; other tasks can be inserted.

Select a task and click **Insert** to specify task parameters. See [Analysis Tasks](#), page **5-14**.

Delete

Removes the selected (highlighted) task.

Edit

Use to edit or view details applicable to the selected task.

In the Analysis Conditions portion of a sample file with an **Analyzing** or **Complete** status, this button displays as **View**.

Clear

Clears the **Selected Tasks** list of all tasks.

Step Detail

Shows details of the selected task without having to open the associated dialog.

Backfill gas

Click to select a gas for backfilling the sample tube prior to evacuation. Ensure the gas selected is either the one used in the previous task or helium.

Match transducer at start

Use to match the port and analysis transducers before analysis begins. In a sequence analysis, this will apply only to the first analysis on a port.

Analysis Termination group box	Enabled when Automatically collected as the type of data on the Sample Information dialog is selected. Use to specify analysis conditions for termination of the analysis.
Cool to less than 50 °C (323 K)	<p>Use to cool the sample to a temperature less than 50 °C (323 K) before the analysis terminates.</p> <p>In a sequence analysis, Cool to less than 50 °C will apply only for the last temperature-controlled analysis on a port.</p>
Backfill sample tube	<p>Use to have the sample tube backfilled. Use the Backfill gas option (explained on the previous page) to select the gas.</p> <p>In a sequence analysis, Backfill sample tube applies only for the last temperature-controlled analysis on a port.</p>
Disable temperature control	Use to manually control the temperature for each stage of the analysis.
Manually Entered Analysis Data	Enabled when Manually entered as the type of data on the Sample Information dialog is selected. Use to enter analysis conditions.
Adsorptive	Select the adsorptive used in the experiment which produced the data. Gases available in this list are those specified in the Gas Table Defaults dialog. See Gas Defaults / MFC Constants , page 8-14.
Temperature	Enter the temperature at which the analysis was performed.
Free space	Enter the free-space volume determined in the analysis.

Analysis Tasks

Evacuation

To ensure safe operation and reliable results, you should include an evacuation task under the following conditions:

- Between tasks using different gases
- Preceding a leak test

- Preceding an analysis

If an evacuation is not inserted as specified above, a warning is displayed.

All fields on this dialog are disabled during analysis or if the sample file has a *Complete* status.

Evacuation	Use to specify conditions during evacuation.
Evacuation rate	Enter a rate at which evacuation is to occur.
Unrestricted evac pressure	This value represents the pressure at which unrestricted sample evacuation begins.
Evacuate for __ below __	Enter the number of minutes and pressure for preliminary evacuation.
Temperature	Use to select temperature options during evacuation. These options are disabled during analysis or if the analysis is complete.
	Enter the temperature during evacuation in the Temperature field.
	Enter the rate at which the temperature is to change (ramp rate) in the Rate field.

Flow

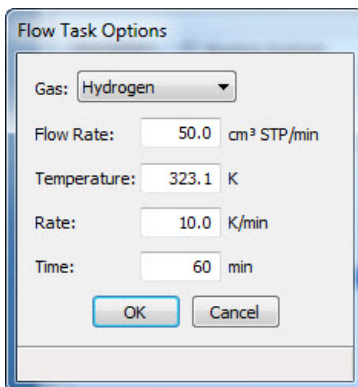

The 'Flow Task Options' dialog box contains the following fields and controls:

- Gas: Hydrogen (dropdown menu)
- Flow Rate: 50.0 cm³ STP/min
- Temperature: 323.1 K
- Rate: 10.0 K/min
- Time: 60 min
- Buttons: OK, Cancel

Gas

Use to select a gas for the Flow task. Do not use ammonia for this task.

The gases in this drop-down list are those specified in the Gas Table Defaults dialog. See [Gas Defaults / MFC Constants](#), page 8-14 for information on changing or adding gases.



The MFC contains Viton which may swell and cause erratic MFC control. Please contact your Micromeritics representative if flowing NH₃ is required during the preparation and activation of your sample.

Enter the rate at which to flow gas.

Flow rate

Enter the temperature at which the gas is to start flowing.

Temperature

Enter the rate at which the temperature is to change (ramp rate) while advancing to the target temperature.

Rate

Enter the duration of time the sample is to remain at the specified temperature.

Time

Leak Test

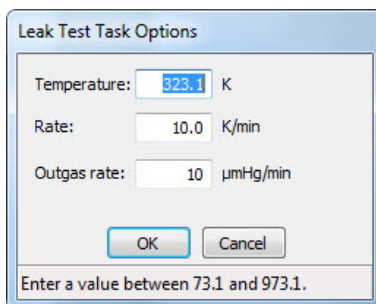

The 'Leak Test Task Options' dialog box contains the following fields and controls:

- Temperature: 323.1 K
- Rate: 10.0 K/min
- Outgas rate: 10 μmHg/min
- Buttons: OK, Cancel
- Footer text: Enter a value between 73.1 and 973.1.

Temperature	Enter the target temperature during the leak test.
Heat rate	Enter the rate at which the temperature is to change (ramp rate) while advancing to the target temperature.
Outgas rate	<p>Entry in this field allows a system check for tasks or sample outgassing before the analysis. The leak test allows sample pressure to rise during the test. If the pressure rises more than the value in this field, the analysis proceeds but you are notified with an error message. The default of 10 μmHg is recommended.</p> <p>The results of the leak test are printed in the Options Report. Leak testing slightly increases analysis time, but it allows the program to notify you of any analyses which may contain erroneous results.</p>

Soak

Soak Task Options

Gas: Hydrogen

Temperature: 323.1 K

Rate: 10.0 K/min

Time: 60 min

Minimum pressure: 0 mmHg

The sample pressure will be maintained between 0 and 30 mmHg.

OK Cancel

Gas	Use to select a gas for the Soak task. Gases available are those specified in the Gas Table Defaults dialog. See Gas Defaults / MFC Constants , page 8-14 for information on changing or adding gases.
Temperature	Enter the temperature at which soaking is to begin.
Rate	Enter the rate at which the temperature is to change while advancing to the target temperature.
Time	Enter the duration of time the sample is to soak at the specified temperature.
Minimum pressure	Enter the minimum pressure to which the sample is to be exposed during soaking.

Analysis

You can include only one Analysis task in the Task list.

The screenshot shows the 'Analysis Task Options' dialog box. It is divided into several sections:

- Adsorptive:** A dropdown menu set to 'Carbon Monoxide'. To its right are buttons for 'Pressure...', 'Equilibration...', and 'Free Space...'.
- Temperature:** A text field for 'Temperature' containing '323.1 K' and a text field for 'Rate' containing '10.0 K/min'.
- Dosing:** A section containing:
 - 'Relative target tolerance:' set to '5.0 %'
 - 'Absolute target tolerance:' set to '5.000 mmHg'
 - An unchecked checkbox for 'Maximum volume increment:' with a value of '1.115369 mmol/g'
 - A checked checkbox for 'Low pressure incremental dose mode' with a 'Dose amount:' of '0.0000 mmol/g'
- Repeat:** A section containing:
 - An unchecked checkbox for 'Repeat analysis'
 - 'Evacuation rate:' set to '5.0 mmHg/s'
 - 'Unrestricted evac. pressure:' set to '5.0 mmHg'
 - 'Evacuate for:' set to '60 minutes below 10 µmHg'

At the bottom of the dialog are 'OK' and 'Cancel' buttons.

All fields on this dialog, as well as on the subdialogs accessed using the buttons, are disabled for sample files that have a **Complete** status.

Adsorptive

Use to elect an adsorptive gas for the analysis. The gases listed are those specified in the Gas Table Defaults dialog. See [Gas Defaults / MFC Constants](#), page 8-14 for additional information on specifying adsorptive gases.

Temperature

Use to specify temperature parameters for the analysis. These options are disabled during analysis.

Enter the analysis temperature in the **Temperature** field and the rate at which the temperature changes in the **Rate** field.

Dosing

Use to specify conditions for dosing the sample.

Relative target tolerance	The values in these fields are used to determine how close the actual pressure must be to each target pressure from the pressure table. At lower pressures the relative tolerance value is smaller, and at higher pressures the absolute tolerance value is smaller.
Absolute target tolerance	
	For example, with relative tolerance = 5% and absolute tolerance = 5 mmHg, the relative tolerance at 40 mmHg target pressure is 5% of 40 mmHg, or 2 mmHg; 2 mmHg is smaller than the absolute tolerance of 5 mmHg, so 2 mmHg is used. At 200 mmHg target pressure, the relative tolerance is 5% of 200 mmHg, or 10 mmHg; in this case, the absolute tolerance of 5 mmHg is smaller and is used.
	In the above example, a minimum pressure of $40 - 2 = 38$ mmHg must be attained to collect data for a target pressure of 40 mmHg. For a target of 200 mmHg, $200 - 5 = 195$ mmHg must be attained.
Maximum volume increment	Select to determine when additional data points are collected between target pressures in regions of adsorption. When the maximum increment has been adsorbed since the last collected data point, another point is equilibrated and collected.
Low-pressure incremental dose mode	Select to dose the sample successively with a specified amount of gas until the first pressure point is reached. Because the data points recorded during Incremental Dose Mode may define most of the analysis, one point on the pressure table can be sufficient and serve as the end point for the analysis. This mode measures equilibrium points at approximately equal intervals on the volume adsorbed axis. Each dose is fully equilibrated and recorded as a data point.
Dose amount	Enabled when Low-pressure incremental dose mode is selected. Use to specify the amount of gas to be added to the sample for each data point until the first point on the pressure table is reached.



Tight tolerance may lengthen the analysis.

Repeat

Use to specify conditions for a repeat analysis.

Repeat analysis

Select to repeat the analysis. The initial analysis measures chemisorption and physisorption activity. The repeat analysis measures only physisorption activity. The difference between the initial and repeat analysis is the strong chemisorption activity of the sample.

Evacuation rate

Enter a rate for evacuation. A rate of 25 to 50 is sufficient for most samples.

Unrestricted evac pressure

This value represents the pressure at which unrestricted sample evacuation begins.

Evacuate __ below __

Enter the number of minutes for preliminary evacuation. Preliminary evacuation takes place prior to the free-space measurement.

Pressure

Displays the Pressure Table dialog so that you may create or edit a pressure table.

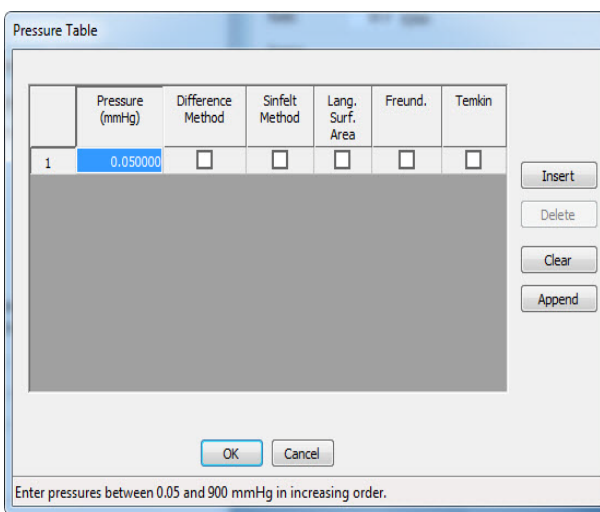

A pressure table is a table of pressure points at which data are to be collected. The pressures may span the entire range from the lowest absolute value of 0.050 to the maximum value of 900 mmHg.

These points are used for the first analysis and the repeat analysis (if selected); however, the low-pressure dose does not apply for the repeat analysis.

Pressure
(continued)

Several analysis conditions files are included with the ChemiSorb software. You can load one of these files into your file using the **Replace** button as a starting point. Edit the values as appropriate for your analysis.

The pressure table for automatically collected data includes the pressure points for data collection and identifies which points are used in reports.

The pressure table must contain a sequence of strictly ascending absolute pressures. A maximum of five hundred pressure points may be entered.

Use the check boxes to have the pressure points included in the reports.

Insert

Inserts a row above the selected one.

Delete

Deletes the selected row.

Clear

Removes all but one entry from the table; one entry is required. A warning message appears requesting confirmation before the table is cleared.

Append

Adds a row at the end of the table.

Equilibration

Displays the Equilibration dialog.

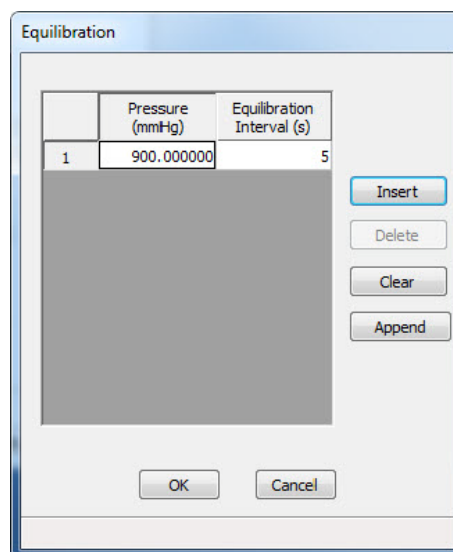

The table contains a list of absolute pressures and equilibration intervals.

Equilibration Interval

The number of seconds between successive pressure readings during equilibration. Long equilibration intervals tend to lengthen analyses, however, they do improve data integrity. Short equilibration intervals produce a faster analysis but may reduce the accuracy of data.

Insert

Inserts a row above the selected one.

Delete

Deletes the selected row.

Clear

Removes all but one required entry from the table. The rows do not have to be selected. A warning message appears requesting confirmation before the table is cleared.

Append

Adds a row to the end of the table.

Free Space

Displays the Free Space Options dialog so that you can specify free-space measurement conditions.

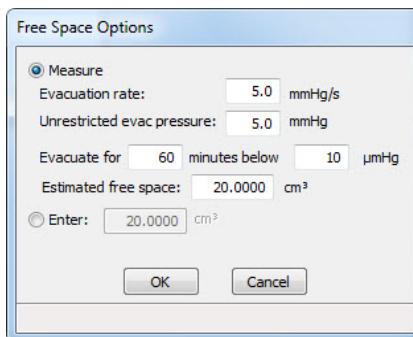
**Measure**

Select to have free space measured automatically by the system at the end of analysis. The radio button is disabled during analysis. It is also disabled when analysis is complete if free space was not measured during analysis.

Evacuation rate

Enter the evacuation rate.

Unrestricted evac pressure

Enter the pressure at which unrestricted sample evacuation is to begin.

Evacuate for __ minutes below __

Enter the number of minutes for preliminary evacuation. Preliminary evacuation takes place prior to the free-space measurement.

Estimated free space

Enter the gas capacity of the sample tube. It is important to provide a reasonable estimate in the field. In most cases, 20 to 25 is appropriate.

Enter

Select to enter free space manually. This option may be necessary if the sample retains helium, and measurement of pressures below 0.1 mmHg is required. (The radio button is disabled during analysis.)

Report Options

Report options specify the types of reports generated from an analysis or manually entered data. They also help you customize details of reports such as axis scale, axis range, and column headings. A report options file may be created as an independent file, or as part of a sample information file.

See [Report Options](#), page 3-7 for step-by-step instructions on creating report options files.

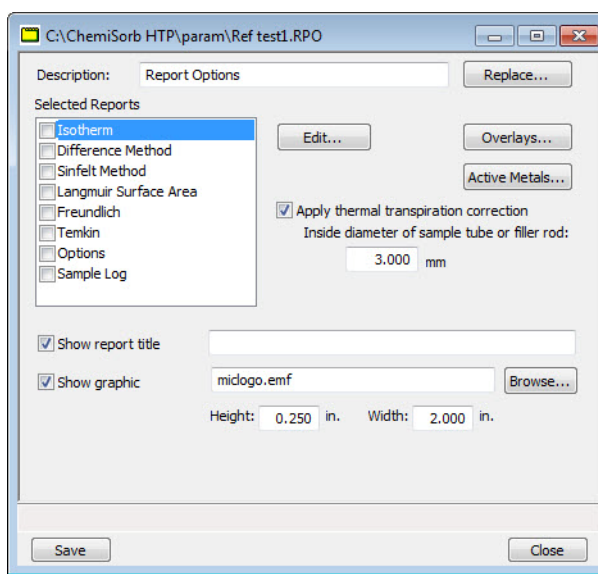

Description

Contains the description of the current Report Options file.

If this is a new file, this field contains the description you specified as the default. Enter a new description or add to the existing one.

Replace

Use to replace the values in the current report options file with those from an existing file. A dialog is displayed so that you may select the file. Select the file, click **Replace**, and the values are copied into the current file automatically. Edit the values in the new file; it will not affect the original file.

Selected Reports

Lists the available reports. Click the check box to the left of the report to select it; a check mark is placed in the box when selected.

The following reports are available:

- Isotherm
- Difference Method
- Sinfelt Method
- Langmuir Surface Area
- Freundlich
- Temkin
- Options
- Sample Log

Edit

Displays an associated dialog for the selected report. Editing options for available reports are shown in the subsequent sections.

This button is disabled for the Options and Sample Log reports.

Overlays

Use to select the sample files to use in the overlay function.

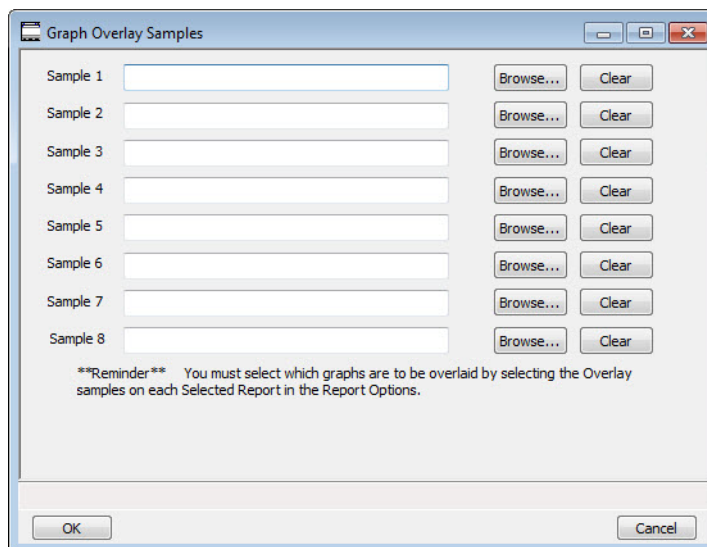

Click **Browse** to the right of each field to select the file. Select up to eight files.

Use **Clear** to clear the field of its entry.

Active Metals

Use to specify the characteristics of up to fifteen elements used in an analysis.

	Element	Atomic Weight	Atomic Cross. Sect. Area (nm ²)	Density (g/cm ³)	% of Sample Weight	% Reduced	MxOy,X	MxOy,Y
1	chromium	51.996	0.0635	7.190	0.00	100.00	1	0
2	cobalt	58.933	0.0662	8.900	0.00	100.00	1	0
3	copper	63.540	0.0680	8.960	0.00	100.00	1	0
4	molybdenum	95.940	0.0730	10.220	0.00	100.00	1	0
5	nickel	58.710	0.0649	8.902	0.00	100.00	1	0
6	palladium	106.400	0.0787	12.020	0.00	100.00	1	0
7	platinum	195.090	0.0800	21.450	0.50	100.00	1	0
8	rhenium	186.200	0.0649	21.020	0.00	100.00	1	0
9	rhodium	102.905	0.0752	12.410	0.00	100.00	1	0
10	silver	107.868	0.0869	10.500	0.00	100.00	1	0

Element

This column displays the active metals specified in the Active Metals Table Defaults dialog (Options menu). This list can be customized using the defaults dialog. See **Appendix D**, page **D-1** for a list of metals.

Atomic Weight

The atomic weight of the element.

Atomic Cross. Sect. Area (nm²)

The atomic cross-sectional area of the element.

Density (g/cm³)

Lists the element's density.

% of Sample Weight

Use to enter the percentage of the element contained in your sample.

If the composition is specified as a pure metal, X=1 and Y=0 for MxOy - the % of sample is for a pure metal. If a metal oxide composition is specified, Y > 0 - the % sample is based upon a metal oxide.

% Reduced

The percent of metal reduced during preparation.

MxOy, X

The number of metal atoms in the oxide.

MxO_y, Y

The number of oxygen atoms in the oxide.

Adsorptive

Use to specify the stoichiometry factors for each adsorptive associated with a selected element. The adsorptives and stoichiometry factors for the selected element are displayed.

	Adsorptive	Stoichiometry Factor
1)	Helium	2.000
2)	Hydrogen	2.000
3)	Carbon Monoxide	1.000
4)		1.000
5)		1.000
6)		1.000
7)		1.000
8)		1.000

Adsorptive

Gases available are those specified in the Gas Table Defaults dialog. See [Gas Defaults / MFC Constants](#), page 8-14.

Stoichiometry Factor

A factor which expresses the ratio between the number of active metal molecules and the number of adsorbate molecules.

Insert

Inserts a row above the selected one.

Delete

Deletes the selected row.

Clear

Removes all but one entry from the table; one entry is required. A confirmation query is displayed before the table is cleared.

Append

Adds a row at the end of the table.

Apply thermal transpiration correction

Select to correct for the temperature-induced pressure difference between the manifold and the sample tube. This option is most significant for pressures less than approximately 1.0 mmHg.

Inside diameter of sample tube or filler rod	Enabled when Apply thermal transpiration correction is selected. Use to enter the inside diameter of the sample tube or filler rod.
Show report title	<p>Use to have a title display on a report. Enter up to 50 characters.</p> <p>If this is a new file, the title you specified as the default is displayed. Accept the default title or enter a different one.</p> <p>If this option is deselected, a title will not display on report(s).</p>
Show graphic	<p>Use to have an graphic display above the report title. For example, to display a company logo. Use a bitmap (bmp) or an enhanced metafile (emf).</p> <p>Click Browse to select the graphic, then enter the height and width in the appropriate fields. This image can also be edited from the report window.</p>

Isotherm Report Options

The isotherm report indicates adsorption of a gas by a solid held at constant temperature.

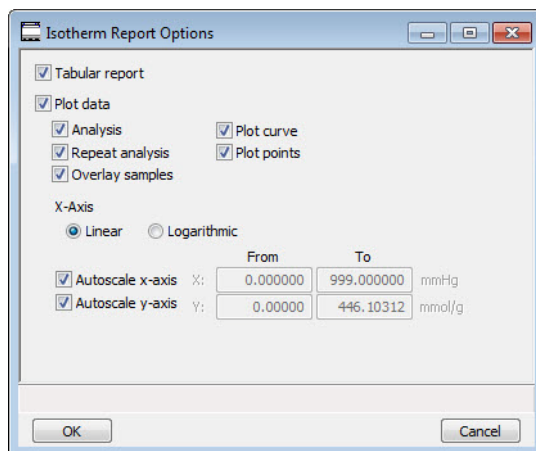

Print tabular report	Select to have collected data printed in a tabular format.
Plot data	Select to have data plotted as a graph.
Analysis	Includes an isotherm plot for the primary analysis.
Repeat analysis	Includes an isotherm plot for a repeat analysis.
Overlay samples	Select to overlay the current plot with those of other samples. Click Overlays on the Report Options dialog to select the sample files.
Plot curve Plot points	Use to specify in which manner to have the data plotted. You can plot data as a curve, points, or both.
X-Axis Scale	Use to have the x-axis displayed on a logarithmic or linear scale.

Autoscale Options

Select **Autoscale** to have the X- and/or Y-axes automatically scaled. Linear X-axes begin at zero, and logarithmic X-axes begin at an appropriate value. Y-axes begin at zero. The system uses the highest values collected during analysis as the ending points for axes ranges.

From/To fields

Enabled when **AutoScale** is not selected. Use to specify beginning and ending values for the X- and Y-axis ranges. Data collected outside these ranges are not included in the plot.

The value entered in the **To** field must be greater than the value entered in the **From** field.

The X-Axis Range fields show the pressure.

The Y-Axis Range fields show the quantity of gas adsorbed.

Difference Method Report Options

The Difference Method report consists of a summary page, a tabular report, and a line fit plot.

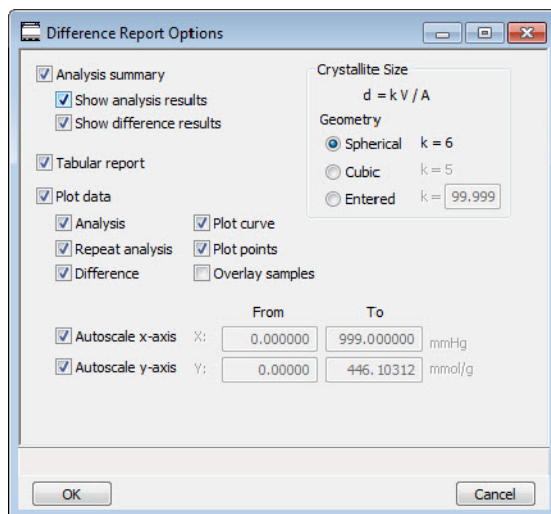

Print analysis summary

Select to print a summary of analysis difference results.

Show Analysis results generates a summary of the following for the first analysis:

- Percent metal dispersion
- Metallic surface area
- Volume adsorbed
- Slope
- Correlation coefficient

Show difference results generates a summary of the differences between the following information for the first and repeat analyses:

- Percent metal dispersion
- Metallic surface area
- Average difference volume

Print tabular report

Select to have analysis data printed in a tabular format.

Plot Data

Select to produce a graph showing the line fit difference between the analysis and repeat analysis.

Analysis	Includes a line fit plot for the primary analysis.
Repeat analysis	Includes a line fit plot for the secondary analysis.
Difference	Plots the difference between the analysis and repeat analysis lines.
Plot curve Plot points	Use to specify the manner in which to have data plotted. You can plot data as a curve, points, or both.
Overlay samples	Use to overlay data from the current sample with that of other samples. Click Overlays on the Report Options dialog to select the other sample files.
Crystallite size	Use to specify the crystallite shape of the sample, or to enter one.
Autoscale Options	Select to have the X- and/or Y-axes automatically scaled. The system uses the highest values collected during analysis as the ending points for an axis range.
Axis Range	<p>Enabled if AutoScale is not selected. Use to specify beginning and ending values for the X- and Y-axis ranges. Data collected outside these ranges are not included in the plot.</p> <p>The X-Axis Range fields show the pressure.</p> <p>The Y-Axis Range fields show the quantity of gas adsorbed.</p> <p>Valid ranges for these fields are shown in the information bar across the bottom of the dialog.</p>

Sinfelt Method Report Options

Sinfelt Report Options

Analysis summary

- Show analysis results
- Show repeat results
- Show difference results

Tabular report

Plot data

- Analysis
- Plot curve
- Repeat analysis
- Plot points
- Difference
- Overlay samples

Autoscale x-axis X: From 0.000000 To 1,000.000000 mmHg

Autoscale y-axis Y: 0.00000 44.61477 mmol/g

Crystallite Size

$d = k V / A$

Geometry

- Spherical k = 6
- Cubic k = 5
- Entered k = 1.000

OK Cancel

The fields on this screen are the same as the Difference Method report (see page 5-32) with one additional option. Under **Analysis summary**, you can select to **Show repeat results**.

Langmuir Surface Area Report

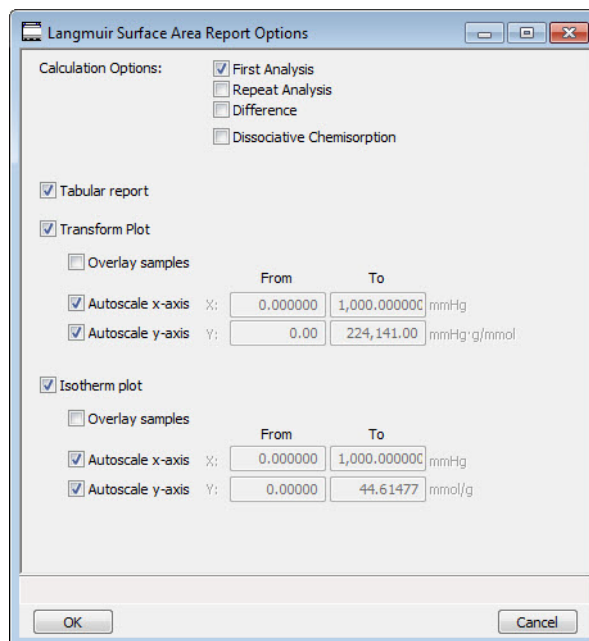

Calculation Options	Use to select the data to include in calculations.
Tabular report	Use to have a tabular report of the plotted data.
Transform plot	Generates a traditional Langmuir surface area plot that is used to determine monolayer volume.
Langmuir isotherm plot	Uses the Langmuir monolayer volume and constant to produce an isotherm.
Overlay samples	Use to overlay the current type plot with those of other samples. Click Overlays on the Report Options dialog to select the other sample files.
Autoscale Options	Use to have the X- and/or Y-axes automatically scaled. The system uses the highest values collected during analysis as the ending points for an axis range.

- From/To** Enabled when **Autoscale** is not selected. Use to specify beginning and ending values for the X- and Y-axis ranges. Data collected outside these ranges are not included in the plot.
- The X-Axis Range fields show the pressure.
- The Y-Axis Range fields show the quantity of gas adsorbed.
- Valid ranges for these fields are shown in the information bar across the bottom of the dialog.

Freundlich Report

The Freundlich isotherm is an empirical isotherm that is used to model low-pressure adsorption data. It can also be applied to model some micropore isotherms.

- Specify the monolayer capacity** Enter the monolayer capacity of the sample.
- Calculation Options** Use to select the data to include in calculations.
- Tabular report** Use to have a tabular report of the pressure points generated.

Transform plot	Plots the linear form of the Freundlich equation.
Freundlich Isotherm plot	Plots the absolute pressure vs quantity adsorbed. Shows best fit line.
Overlay samples	Select to overlay data from the current file with the same type of data from other samples (files). Click Overlays on the Report Options dialog to select the other files.
Autoscale Options	Select to have the X- and/or Y-axes automatically scaled. The system uses the highest values collected during analysis as the ending points for an axis range.
From/To	<p>Enabled if AutoScale is not selected. Use to specify beginning and ending values for the X- and Y-axis ranges. Data collected outside these ranges are not included in the plot.</p> <p>The X-Axis Range fields show the pressure.</p> <p>The Y-Axis Range fields show the quantity of gas adsorbed.</p> <p>Valid ranges for these fields are shown in the information bar across the bottom of the dialog.</p>

Temkin Report

The Temkin isotherm is used to model adsorption data where the heat of adsorption drops linearly with increasing coverage.

Specify monolayer capacity Enter the monolayer capacity of the sample.

Calculation Options Use to select the data to include in calculations.

Specify differential heat of adsorption at zero surface coverage Use to enter the differential heat of adsorption at zero surface coverage. This allows inclusion of all Temkin constants.

Tabular report Use to have a tabular report of the pressure points generated.

Transform plot Plots a linear form of the Temkin isotherm.

Temkin Isotherm plot Overlays the Temkin isotherm with analysis data.

Overlay samples	Select to overlay data from the current file with the same type of data from other samples (files). Click Overlays on the Report Options dialog to select the other files.
Autoscale Options	Select to have the X- and/or Y-axes automatically scaled. The system uses the highest values collected during analysis as the ending points for an axis range.
From/To	<p>Enabled if AutoScale is not selected. Use to specify beginning and ending values for the X- and Y-axis ranges. Data collected outside these ranges are not included in the plot.</p> <p>The X-Axis Range fields show the pressure.</p> <p>The Y-Axis Range fields show the quantity of gas adsorbed.</p> <p>Valid ranges for these fields are shown in the information bar across the bottom of the dialog.</p>

Options Report

The Options Report is a predefined collection of sample information file parameters printed by selecting **Options** from the Report Options dialog. You cannot edit this report.

If Type of Data is **Automatically collected**, the following information appears on the report:

Task Summary	Lists conditions you specified for each task selected.
Analysis Task Options	Details conditions you specified for the analysis task.
Experiment Log	Identifies actual conditions under which each task transpired.
Leak Test Results	Identifies outgas rates and the outcome for each leak test performed.

Redundant data appear in the **Task Summary** and the **Experiment Log** if the instrument is performing correctly.

If Type of Data is **Manually entered**, only the adsorptive gas, sample temperature, and free-space volume are reported.

Sample Log

The Sample Log report provides the following statistics:

- manual control operations performed during analysis
- information entered using on the sample file editor
- warnings and/or errors that occurred during analysis

Collected/Entered Data

If you select **Manually Entered** on the **Advanced** view of the Sample information dialog, an **Entered** tab is added enabling you to enter the data.

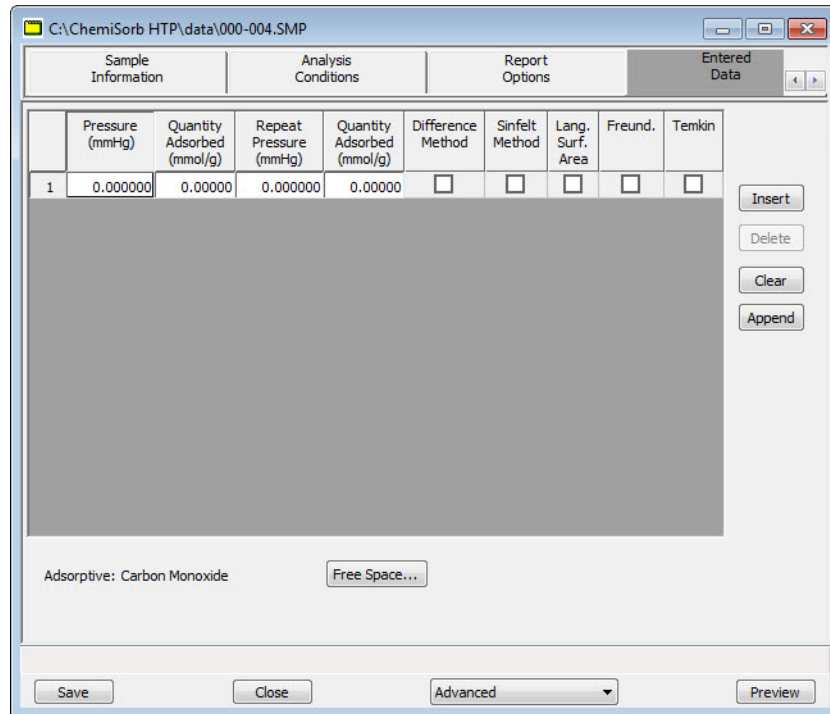

If you select **Automatically collected**, a **Collected** tab is added *after* the analysis is completed. This dialog contains the data points collected during analysis and the specified calculation assignments. You can edit calculation assignments during or after an analysis.

Sample Information		Analysis Conditions		Report Options			Collected Data		
	Pressure (mmHg)	Quantity Adsorbed (mmol/g)	Repeat Pressure (mmHg)	Quantity Adsorbed (mmol/g)	Difference Method	Sinfelt Method	Lang. Surf. Area	Freund.	Temkin
1	0.006521	0.00327	0.000000	0.00000	<input type="checkbox"/>	<input type="checkbox"/>	<input type="checkbox"/>	<input type="checkbox"/>	<input type="checkbox"/>
2	0.309206	0.00454	0.264853	0.00166	<input type="checkbox"/>	<input type="checkbox"/>	<input type="checkbox"/>	<input type="checkbox"/>	<input checked="" type="checkbox"/>
3	0.795406	0.00483	0.771942	0.00192	<input type="checkbox"/>	<input type="checkbox"/>	<input type="checkbox"/>	<input type="checkbox"/>	<input checked="" type="checkbox"/>
4	1.306631	0.00498	1.289601	0.00205	<input type="checkbox"/>	<input type="checkbox"/>	<input type="checkbox"/>	<input type="checkbox"/>	<input checked="" type="checkbox"/>
5	2.490696	0.00517	2.599920	0.00221	<input type="checkbox"/>	<input type="checkbox"/>	<input type="checkbox"/>	<input type="checkbox"/>	<input checked="" type="checkbox"/>
6	4.981225	0.00539	4.988354	0.00238	<input type="checkbox"/>	<input type="checkbox"/>	<input type="checkbox"/>	<input type="checkbox"/>	<input checked="" type="checkbox"/>
7	7.485646	0.00553	7.481072	0.00246	<input type="checkbox"/>	<input type="checkbox"/>	<input type="checkbox"/>	<input type="checkbox"/>	<input checked="" type="checkbox"/>
8	9.997268	0.00567	10.467210	0.00252	<input type="checkbox"/>	<input type="checkbox"/>	<input type="checkbox"/>	<input type="checkbox"/>	<input checked="" type="checkbox"/>
9	12.017632	0.00579	12.578352	0.00258	<input type="checkbox"/>	<input type="checkbox"/>	<input type="checkbox"/>	<input type="checkbox"/>	<input checked="" type="checkbox"/>
10	25.091988	0.00598	25.052376	0.00277	<input type="checkbox"/>	<input type="checkbox"/>	<input type="checkbox"/>	<input type="checkbox"/>	<input checked="" type="checkbox"/>
11	52.654995	0.00622	52.662350	0.00297	<input type="checkbox"/>	<input type="checkbox"/>	<input type="checkbox"/>	<input type="checkbox"/>	<input checked="" type="checkbox"/>
12	105.300705	0.00653	105.311394	0.00325	<input checked="" type="checkbox"/>	<input checked="" type="checkbox"/>	<input type="checkbox"/>	<input type="checkbox"/>	<input type="checkbox"/>
13	155.379288	0.00681	155.365921	0.00356	<input checked="" type="checkbox"/>	<input checked="" type="checkbox"/>	<input type="checkbox"/>	<input type="checkbox"/>	<input type="checkbox"/>
14	205.460461	0.00708	205.447003	0.00378	<input checked="" type="checkbox"/>	<input checked="" type="checkbox"/>	<input type="checkbox"/>	<input type="checkbox"/>	<input type="checkbox"/>

Adsorptive: Hydrogen Free Space...

Save Close Advanced Preview

Pressure table

For **collected data**, columns for the following are displayed:

- pressure
- quantity adsorbed
- repeat pressure
- quantity adsorbed (for repeat pressure)
- calculation assignments for each requested report option

For **entered data**, columns for the following are displayed:

- pressure
- quantity adsorbed
- repeat pressure
- quantity adsorbed (for repeat pressure)
- report assignments

Insert

Use to insert a row above the selected row.

Delete	Use to delete the selected row.
Clear	Clears the table of all but one entry; one is required.
Append	Enabled for entered data. Adds a row at the end of the table.
Free Space	Use to edit free-space values.

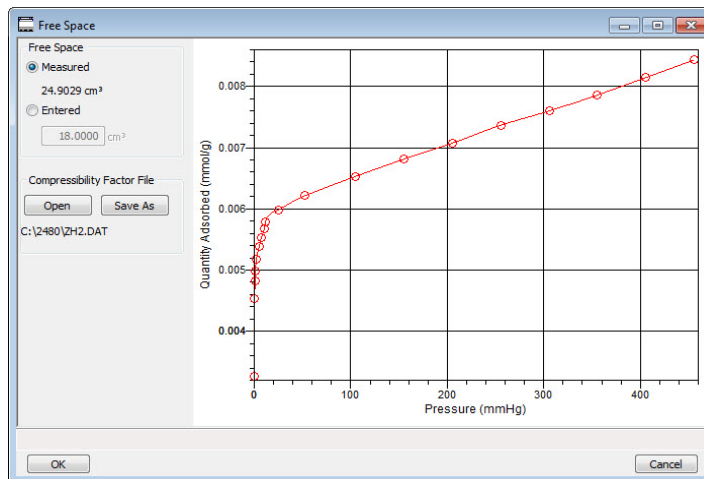

This dialog also shows the isotherm for the analysis. The isotherm is redrawn each time values are edited.

You can also customize parts of the isotherm plot, as well as zoom in for finer detail. Right-click in the graph area to display a shortcut menu displaying the options available. See [Shortcut Menus](#), page 7-13.

Measured	Displays the measured free space if Measured was chosen as the Free-space method for the analysis; these values cannot be edited.
Entered	Use to enter a free-space value.

Save

Use to save the file in the active window under its current name. The **Save** button at the bottom of the main dialogs performs the same function.

Save As

Use to:

- save a sample or parameter file in the active window under a different name. Use this to make a duplicate copy of a file that can be modified without changing the original one.
- save a subset (parameter) of the sample file in the active window as a standalone parameter file. For example, select Analysis Conditions from the Save As menu to create a standalone parameter file of the analysis conditions portion of the active sample file.

Save All

Use to save all open files under their current names. It provides a faster way to save all open files at one time and avoids having to perform a **Save** operation on each individual file.

Close

Use to close the file in the active window.

A prompt displays before closing if the file contains changes that have not been saved.

Close All

Use to close all active files at one time. A prompt displays to save changes.

Print

Use to print the contents of one or more sample or parameter files to the screen, a printer, or a file. For example, when printing the contents of an Analysis Conditions file, the parameters used for all analysis conditions associated with the file(s) are printed. The print dialog is common to all file types.

Select the file type from the drop-down menu; a dialog similar to the following is displayed:

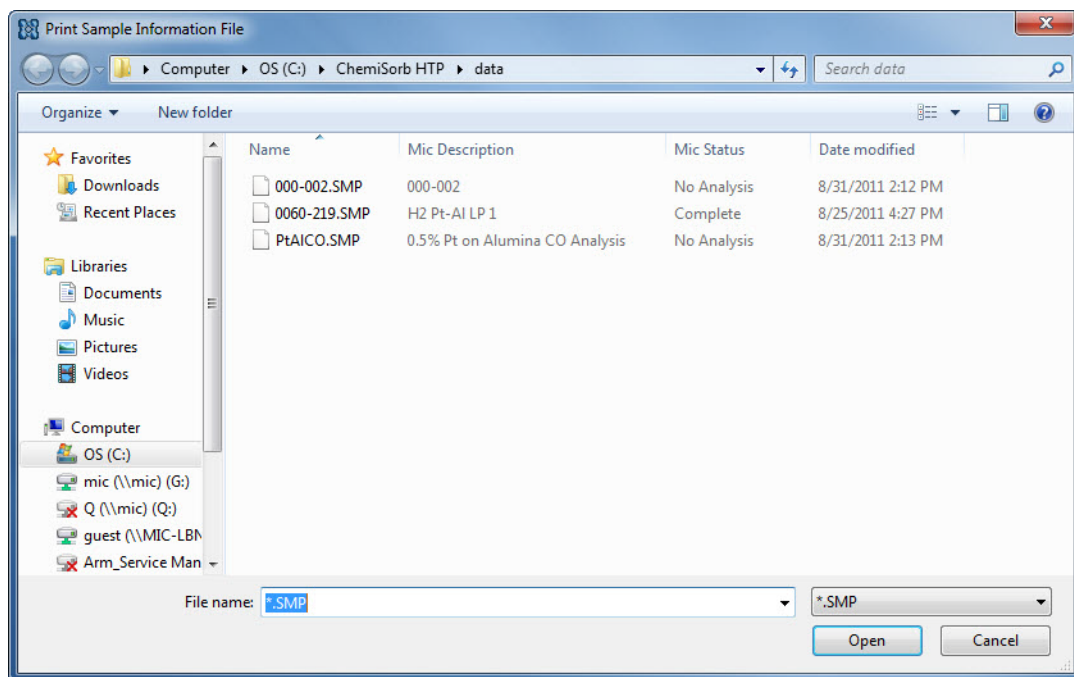
**Files list**

Lists files located in the current directory.

File name

The name of the file selected from the **Files** list is copied to this field.

Open

This button displays the Report Settings dialog.

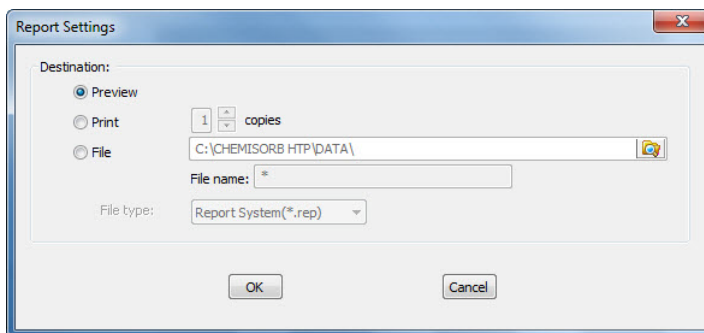

- **Preview:** prints file contents to the screen.
- **Print:** prints file contents to the default printer. Print up to 10 copies.
- **File:** prints file contents to a file. Enter a name in the **File name** field and select one of the following file types from the drop-down list:

rep: system report which can be opened using the Open Report command on the Reports menu.

xls: spreadsheet format

txt: text file

List

Use to display the following information on one or more sample or parameter files:

- File name
- Date the file was created (or last edited)
- Time the file was created (or last edited)
- File identification
- File status

The List dialog is common to all file types.

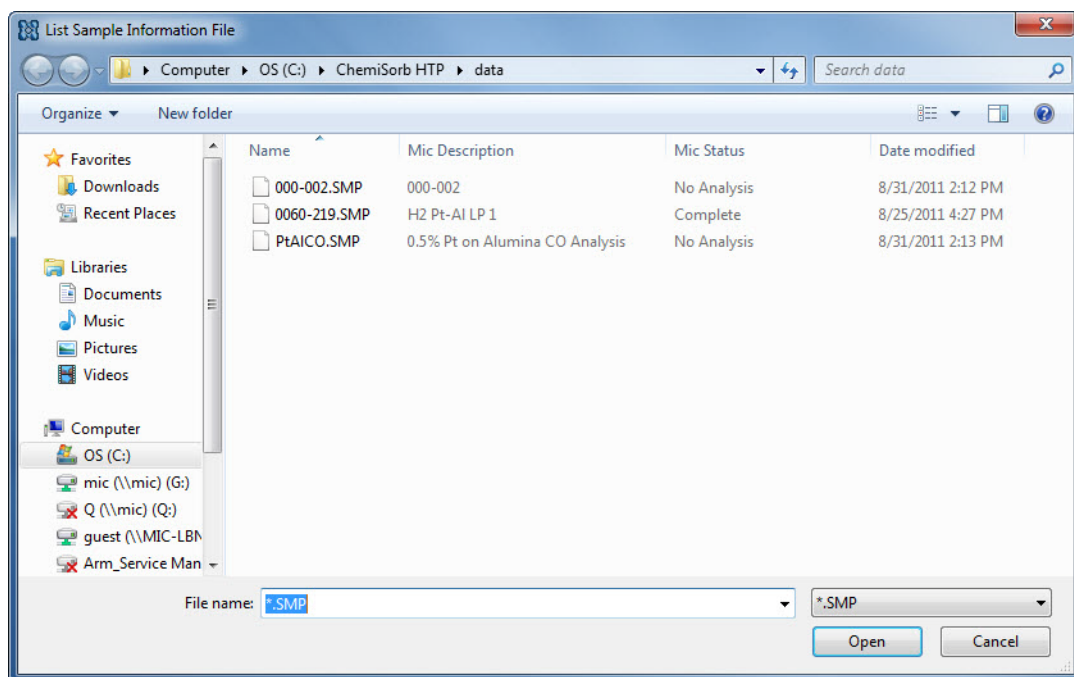

The behavior of the List dialog is the same as the Print dialog; see [Print](#), page 5-45.

Export

Export copies the isotherm data in sample information files and reformats it in .rep, .txt, or .xls format. The output file consists of six columns: pressure, quantity dosed, elapsed time, sample temperature, port temperature, and port assignment. See **Appendix E**, page **E-1** for record descriptions. The data can then be imported into other applications accepting spreadsheet or text file formats.

Select **File > Export** to display the Export Sample File dialog.

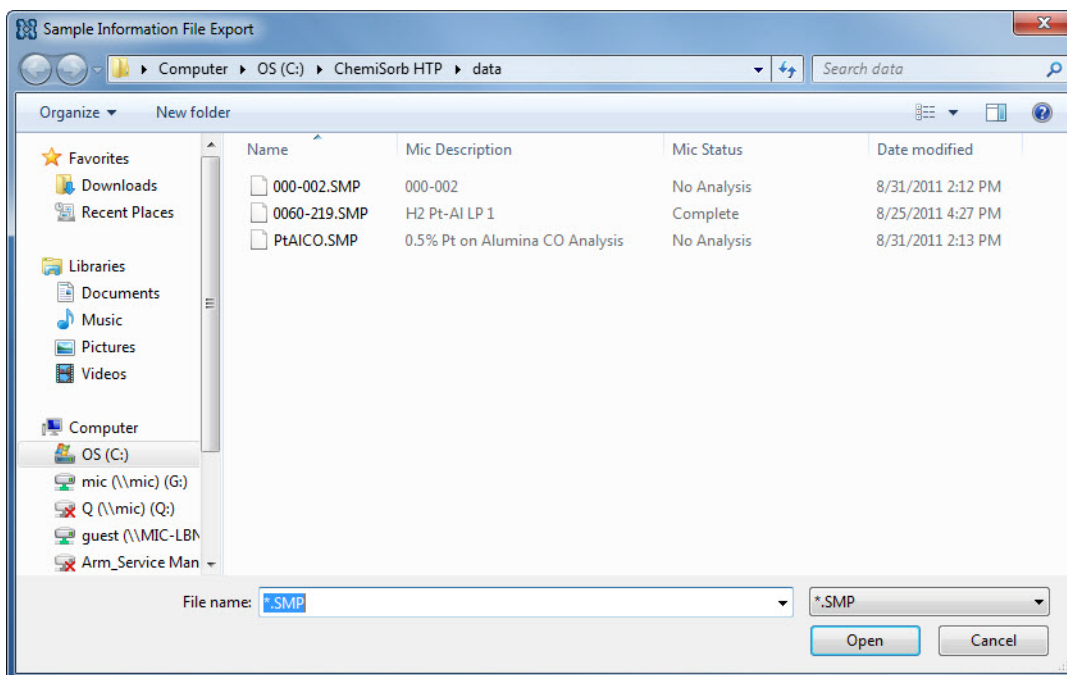
**Files list**

This list contains the files located in the current directory.

File name

The name of the file you select from the **Files** list is copied to this field.

Open

This button displays the Export Settings dialog.

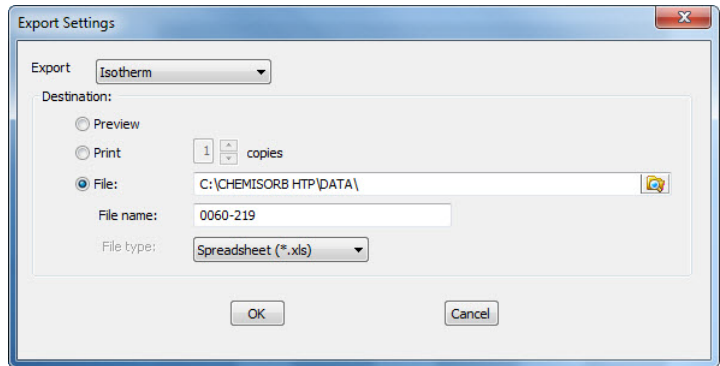

- **Preview:** prints file contents to the screen.
- **Print:** prints the isotherm data to the default printer. Print up to 10 copies.
- **File:** prints the isotherm data to a file. Enter a name in the **File name** field and select one of the following file types from the drop-down list:

rep: system report which can be opened using the Open Report command on the Reports menu.

xls: spreadsheet format

txt: text file

Format of Data Output

This example shows the format of the output file for exported data.

ChemiSorb HTP Version 1.01 - [Export 0060-219.SMP]

Export 0060-219.SMP

H2 Pt-AI LP 1
samv
102
-
0.748000
0
19

0.006521	0.00245	5	308.28	298.89	0
0.309206	0.00380	23	308.25	298.78	0
0.795406	0.00465	33	308.18	298.69	0
1.306631	0.00544	42	308.20	298.70	0
2.490696	0.00713	54	308.18	298.58	0
4.981225	0.01057	66	308.16	298.59	0
7.485646	0.01396	75	308.19	298.56	0
9.997268	0.01738	85	308.14	298.58	0
12.017632	0.02014	94	308.19	298.56	0
25.091988	0.03761	103	308.12	298.55	0
52.654995	0.07449	112	308.20	298.51	0
105.300705	0.14468	121	308.16	298.54	3
155.379288	0.21140	128	308.14	298.47	3
205.460464	0.27808	136	308.18	298.47	3
255.511902	0.34476	143	308.09	298.47	3
305.598267	0.41148	151	308.19	298.38	3
355.685760	0.47812	158	308.21	298.41	3
405.691498	0.54475	166	308.10	298.41	3
455.810425	0.61153	174	308.16	298.37	3
0.264853	0.00159	253	308.08	298.35	0

Exit

Use to close the ChemiSorb program. When selected, analyses in progress continue until completion; analysis data are collected and stored in the analyzer's memory.

- If a window containing a modified file is open, you are queried to save before closing.
- If an analysis is in progress, the following message is displayed:

2459- An instrument is busy. A delay in restarting this application could result in loss of data. Continue with program exit?

Yes

No

Yes exits the ChemiSorb program. The analysis continues and data are collected.

No allows the program to remain active.

6. UNIT MENU

The Unit menu contains the options for the operations that can be performed with the ChemiSorb HTP analyzer. The main menu contains a Unit menu for each attached analyzer. For example, if two analyzers are attached, the main menu contains two Unit menus. The appropriate unit number and serial number display in the title bar of the operational windows. The status windows also display in different colors.



The Unit menu does not display on the menu bar if the analysis program is being used for offline data manipulation on a computer other than the one controlling the analyzer.

Description

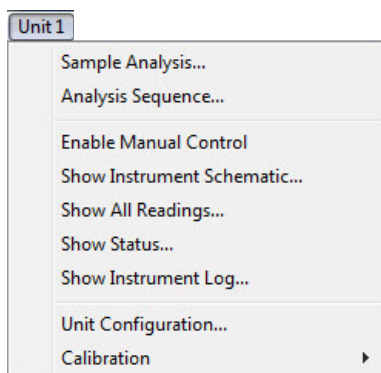

Listed below are brief descriptions of the Unit menu options. Detailed descriptions are found on the pages indicated.

Sample Analysis	Use to perform an analysis. Page 6-3
Analysis Sequence	Use to schedule a series of analyses. Page 6-8
Enable Manual Control	Use to control certain components of the system manually. Page 6-13
Show Instrument Schematic	Displays a schematic of the analyzer components. Page 6-18
Show All Readings	Use to view the pressure and temperature calibrations. Page 6-19

Show Status	Shows the status window for the selected unit. Page 6-20
Show Instrument Log	Displays a log of recent analyses, calibrations, and error messages. Page 6-22
Unit Configuration	Displays software version, hardware configuration, and calibration information. Use to assign gases to analyzer ports. Page 6-24
Calibration	Use to calibrate certain components of the analyzer. Page 6-26

Sample Analysis

When **Unit >Sample Analysis** is selected, the Analysis dialog is displayed. Use to select files for performing up to six analyses. During the analysis process, any one analysis can be cancelled without cancelling the other analyses.

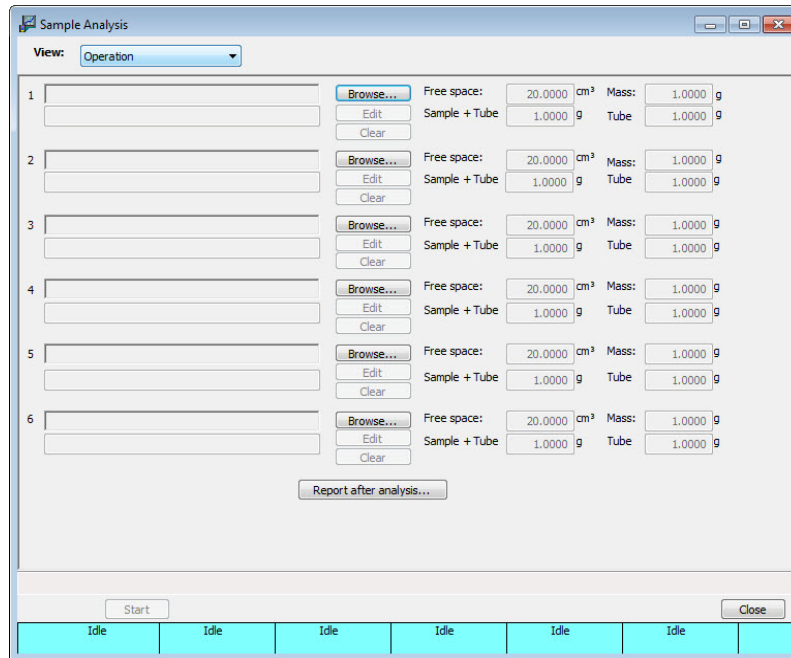

View

Use to view one of the following in the current window:

- the current operation
- the instrument schematic
- the instrument log
- status
- all readings (see [Show All Readings](#), page 6-19)

Browse

Use to select a sample file for the associated port. When a file is selected, the path name and description are displayed.

The files selected for any port after the first port must pass a compatibility check with the first port's sample file. If the check fails, the file path displays with a red background and an error message lists all parameters that failed the compatibility check.

The following parameters must be the same for all sample files that will be used in analyses run at the same time:

- Backfill gas
- Number of tasks
- For each task, the following parameters must be the same:
 - Type of task
 - Temperature
 - Rate
- For evacuation tasks:
 - Vacuum level
 - Evacuation time
- For soak tasks:
 - Gas
 - Minimum pressure
 - Soak time
- For flow tasks:
 - Gas
 - Flow time
- Analysis gas

Edit

Open the selected sample file to edit the parameters in the file.

After the file is edited, it is checked again for compatibility.

Clear

Removes the selected sample file.

Free Space

Displays the estimated free space.

Mass Enabled if **Enter** is selected in the sample file; displays the value entered for the sample mass.

If **Calculate** was selected in the sample file, the calculated mass is shown in this field, but disabled.

Sample + tube Enabled if **Calculate** is selected in the sample file; displays the mass entered for the **sample + sample tube**.

Tube Enabled if **Calculate** is selected in the sample file; displays the value entered for the **empty sample tube**.

The calculated mass is shown in the **Mass** field (greyed).

Report after analysis Use to specify report and/or export output options.

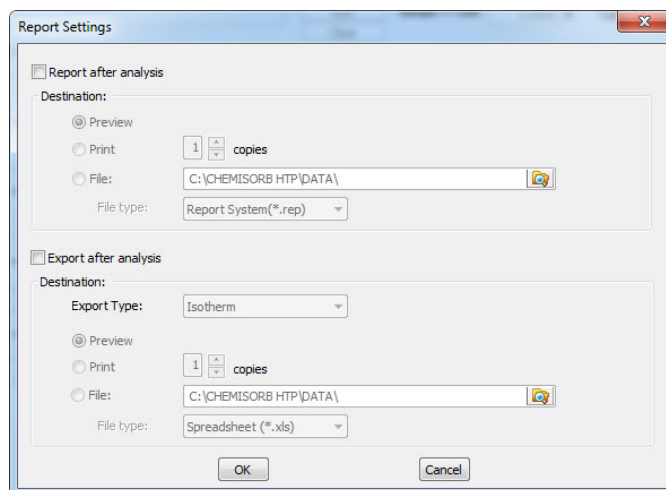

- **Report after analysis** generates selected reports
- **Export after analysis** exports the isotherm data

Preview Generates reports or exports data to the screen. Print a copy from the report window.

Print Generates reports or exports data to the default printer. Print up to 10 copies.

Start Displays the second view of the Analysis dialog. This view of the dialog displays a prompt to raise the elevators and install the insulator disks and safety shields.

If these tasks have been completed, **Next** is enabled. If the tasks have not been completed, complete them to proceed.

Next Displays a message to install the oven insulator disks and safety shields. After installed, click **Next**. The next view of the Analysis dialog is displayed.

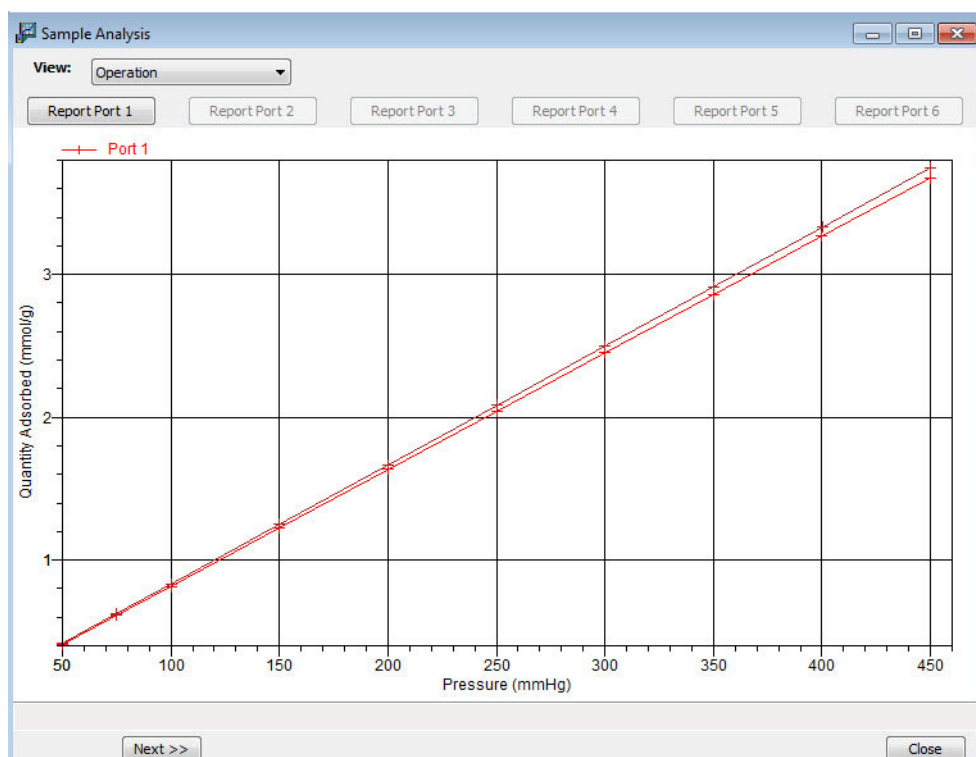

This view of the dialog displays a live graph of data for the analyses in progress. The graph will have up to twelve curves; six for the first analysis on each port and six for the repeat analysis (if requested) on each port.

Report Port [n] Generates a report for the sample on the selected port.

Skip

Use to select the port on which to skip the current step.

Use caution when skipping steps. The ChemiSorb performs multiple steps for a given task. Skipping certain steps may cause corruption of data, instrument damage, or personal injury.



Use caution when using this function. Skipping certain steps can cause personal injury, instrument damage, or may corrupt data.

Resume

Use to select the port to resume a suspended analysis.

Suspend

Use to select the port to suspend an analysis.

Cancel

Use to select the port on which the analysis will be cancelled. Cancelling an analysis on a port does not affect the other analyses in progress.

Close

Enabled at the completion of analysis. Closes the dialog.

Status bar

The status bar across the bottom of the gives the current status of the ports.

Analysis Sequence

Use to perform a series of analyses on one or more ports.

If selected and a sequence analysis is already in progress, the screen will show 4 the steps for the analysis in progress.

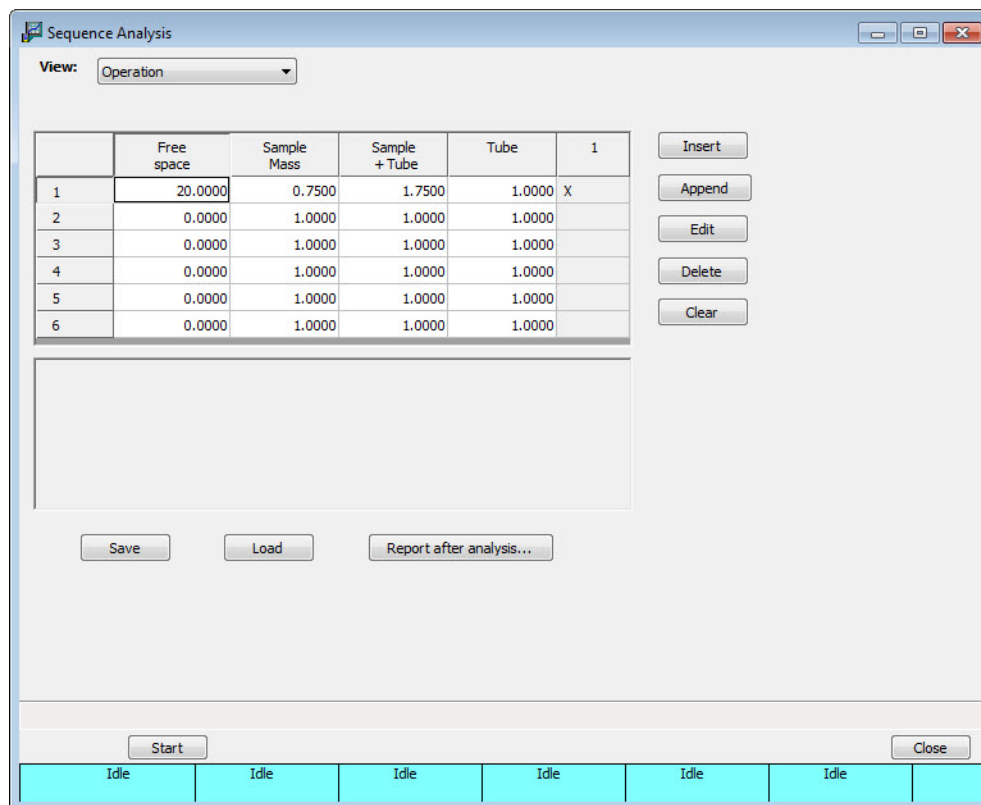

View

Use to view one of the following in the current window:

- the current operation
- the instrument schematic
- the instrument log
- status
- all readings

Sequence Table

Displays the following information for ports 1 through 6:

Free Space

Displays the estimated free space.

Sample Mass	<p>Enabled if Enter is selected in the sample file; displays the value entered for the sample mass.</p> <p>If Calculate is selected in the sample file, the calculated mass is shown in this field, but disabled.</p>
Sample + tube	<p>Enabled if Calculate is selected in the sample file; displays the mass entered for the sample + sample tube.</p>
Tube	<p>Enabled if Calculate is selected in the sample file; displays the value entered for the empty sample tube.</p>
Sequence steps	<p>A column is displayed for each sequence step.</p> <p>The column is marked with an X if the port has a sample file selected for this sequence.</p> <p>Sequence step columns are added using the Insert and Append buttons.</p>
Sequence Step window	<p>Displays the sample files assigned to the selected Sequence step.</p>
Insert Append	<p>Use to select a file for the sequence step being inserted</p> <p>Insert places the step before the selected step. This button becomes enabled after a step has been added.</p> <p>Append places the step at the end of the table.</p>

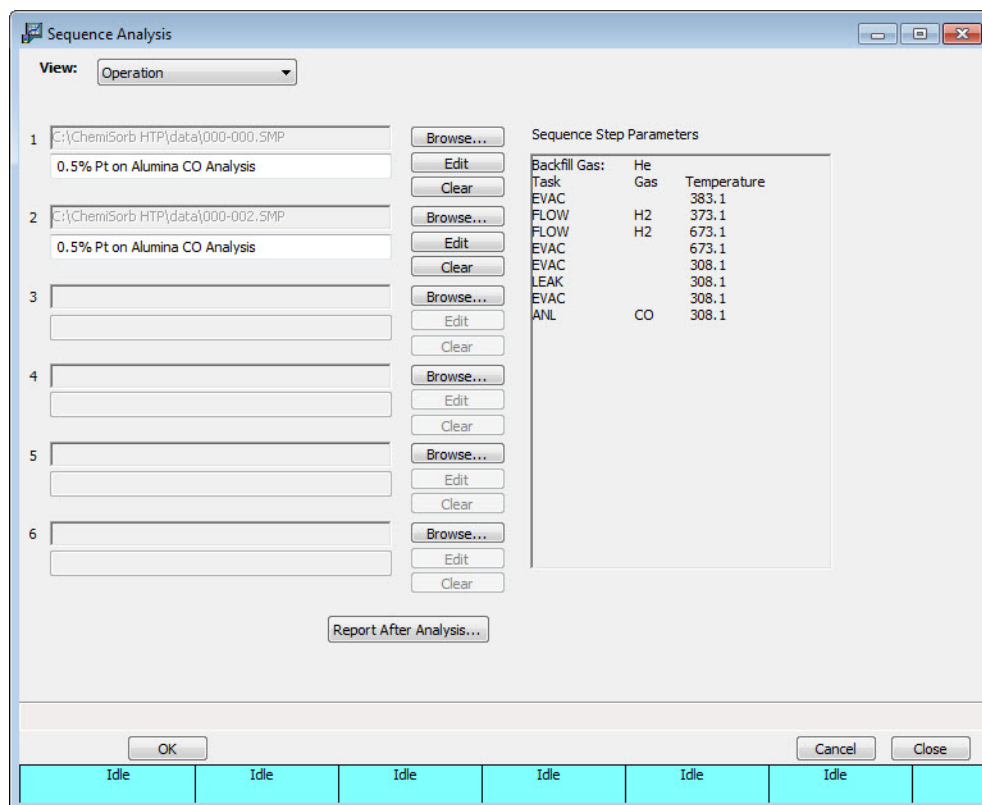
**Browse**

Use to select a sample file for the associated port. When a file is selected, its path name and description are displayed.

After the first file is selected, each subsequent file must pass a compatibility check. If the check fails, the file path displays a red background and an error message lists all entries that fail the compatibility check.

Edit

Use to open the selected sample file for editing.

After the file is edited, it is checked again for compatibility (see above).

Clear

Removes the selected sample file.

Sequence Step Parameters

Displays the tasks entered for the analysis.

Edit	Use to edit or select a different file for the sequence.
Delete	Deletes the selected sequence.
Clear	Removes all sequence steps from the table.
Start	<p>Displays the second view of the Analysis dialog. This view of the dialog displays a prompt to raise the elevators and install the insulator disks and safety shields.</p> <p>If these tasks have been completed, Next is enabled. If the tasks have not been completed, complete them to proceed.</p>
Next	Displays a live graph of data for the analyses in progress. The graph will have up to twelve curves; six for the first analysis on each port and six for the repeat analysis (if requested) on each port..

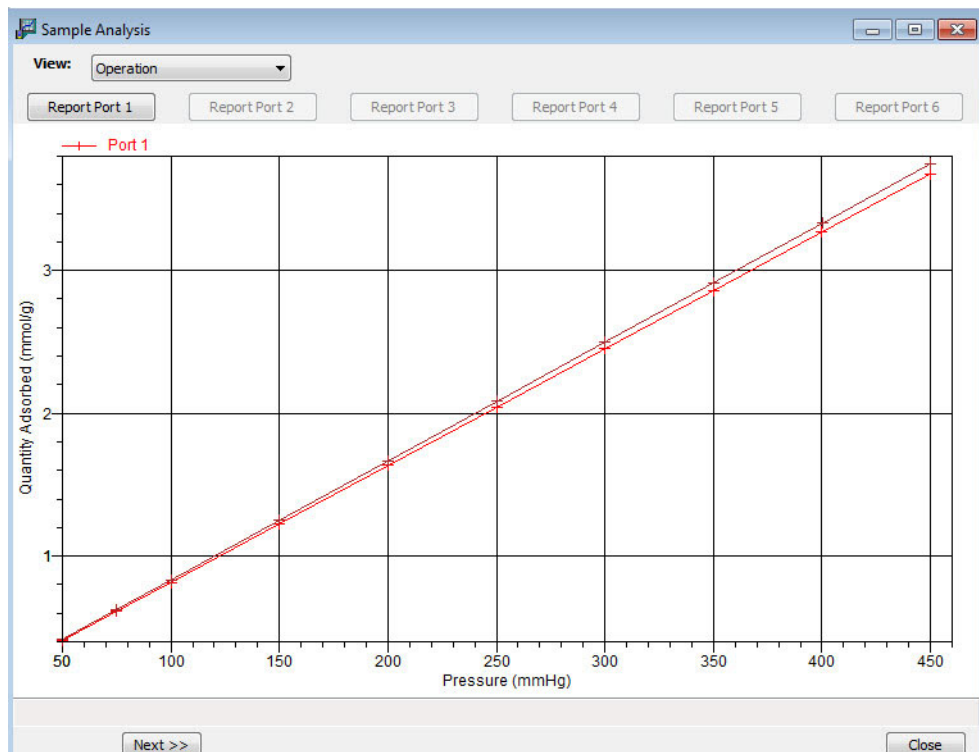

Report Port [n]	Generates a report for the sample on the selected port.
------------------------	---

Skip Use to select the port on which to skip the current step.

Use caution when skipping steps. The ChemiSorb performs multiple steps for a given task. Skipping certain steps may cause corruption of data, instrument damage, or personal injury.



Use caution when using this function. Skipping certain steps can cause personal injury, instrument damage, or may corrupt data.

Resume Use to select the port on which to resume a suspended analysis.

Suspend Use to select the port on which to suspend an analysis.

Cancel Use to select the port on which the analysis will be cancelled. Cancelling an analysis on a port does not affect the other analyses in progress.

Close Enabled at the completion of analyses. Closes the dialog.

Status bar The status bar across the bottom of the gives the current status of the ports and sequence steps.

Enable Manual Control

Use to control certain components of the system manually; the instrument schematic is displayed with manual control enabled.

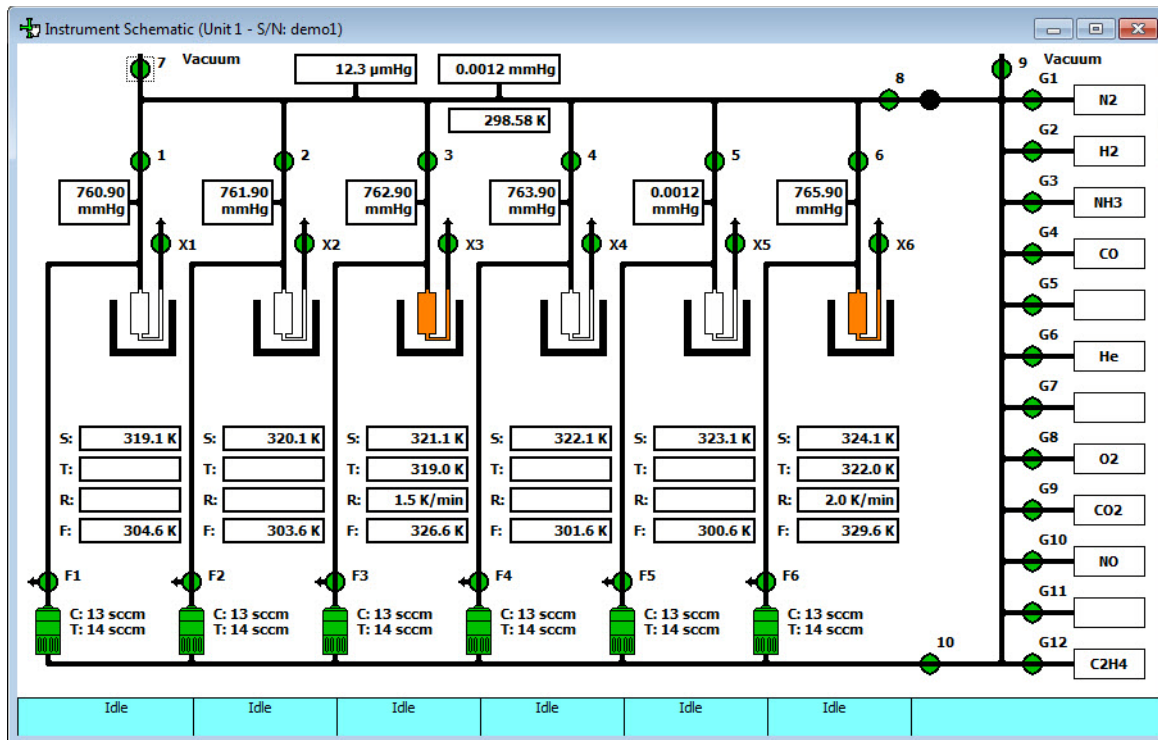

Each component that can be manually controlled has a shortcut menu displaying the operations available for that particular component. These menus may be accessed by selecting the component, then clicking the right mouse button once, or pressing **Shift + F9**.

The options available for the components on the instrument schematic are:

Valves



Actions: Open, Open All, Close, Close All, Pulse

Open and **Close** open and close the valves. Open and close the valves by double-clicking on the valve or by pressing the **Spacebar** while the valve is selected.

Open All and **Close All** open all and close all valves in its series. For example, if a MFC icon is selected and select **Open All**, all MFC valves will open.

Pulse quickly turns the valve on and off, allowing the operation to proceed in small increments. Pulse the valve by pressing **P** while the valve is selected.

System valves and their functions are listed in the following table.

Valve(s)	Description
1 through 6	Sample ports
7	Unrestricted vacuum
8	Supply valve, supplies gas to the manifold
9	Vacuum valve, allows evacuation of gas inlet manifold
10	MFC isolation valve
F1 through F6	MFC valves; purge the gas from the lines when closed
G1 through G12	Gas inlet ports
X1 through X6	Exhaust from sample tube
Unmarked	Servo valve

Servo Valve

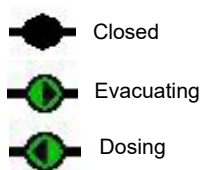

Actions: Set, Close

Set displays the Servo Valve Settings dialog to select to dose or evacuate and specify a target pressure.

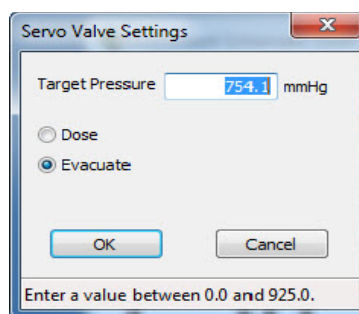

When set, the directional arrow indicates whether it is dosing or evacuating.

Close closes the servo valve.

The **Spacebar** can also be used for operation.

- Press the **Spacebar** when the servo is *closed*, the settings dialog is displayed.
- Press the **Spacebar** when the servo is in *operation*, the servo is turned off.

Sample Tube Furnace/Elevator

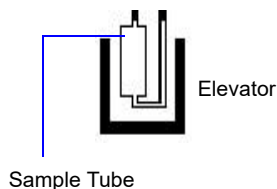

S:	<input type="text" value="49.0 °C"/>	Sample temp.
T:	<input type="text" value="46.8 °C"/>	Target temp.
R:	<input type="text" value="14.2 °C/min"/>	Ramp rate
F:	<input type="text" value="48.5 °C"/>	Furnace temp.

Actions: Set, Raise, Lower, Stop

The sample tube icon is white when the sample and furnace temperature is 50 °C or lower. If either temperature exceeds 50 °C, the sample tube icon will turn orange and the elevator control will be disabled. Temperature readings and ramp rate are displayed below the icon.

The furnace resides on the elevator.

Set displays the Set Temperature Controller dialog. This dialog can also be accessed using the **Spacebar** while the elevator area is selected.

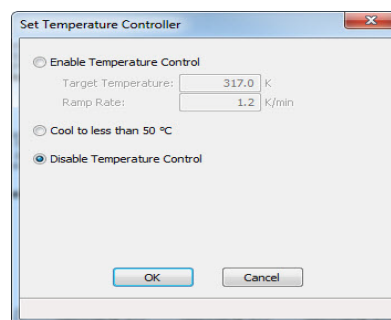

Enable Temperature Control

Use to enter the target temperature and ramp rate. The elevator must be fully raised.

Disable Temperature Control

Use to manually control the temperature; automatic temperature control will be disabled. For example, use when using subambient temperatures for an analysis.

Raise and **Lower** raises and lowers the elevator. An indicator arrow is displayed in the elevator icon to indicate its direction.

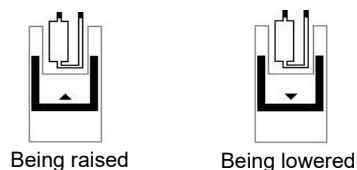

Stop stops the elevator at its current position.

Mass Flow Controller

Actions: Set Flow Rate, Stop Flow

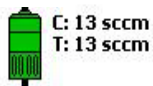

The Mass Flow Controllers (MFCs) control the flow of gas into the sample ports. The current (C) rate and target (T) rate are shown to the right of each MFC icon.

Set Flow Rate - use to enter a flow rate.

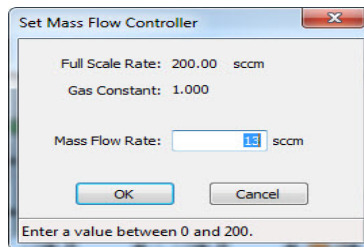

Stop Flow stops the flow of gas.

These components are for informational purposes only; they cannot be controlled manually.

**Manifold Pressure
Vacuum Gauge Pressure
Manifold Temperature**

The group of rectangles on the manifold display the manifold pressure, the vacuum gauge pressure, and the manifold temperature.

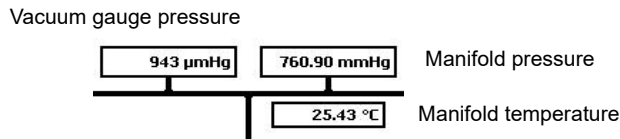

Sample Port transducer

Each sample port has a 1000- and a 10-mmHg transducer; only the reading for the 1000-mmHg transducer is shown on the schematic. Select **Unit > All Readings** to view the reading for the 10-mmHg transducer (see [Show All Readings](#), page 6-19).

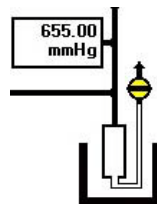

Status bar

The status bar across the bottom of the instrument schematic gives the current status of the ports.

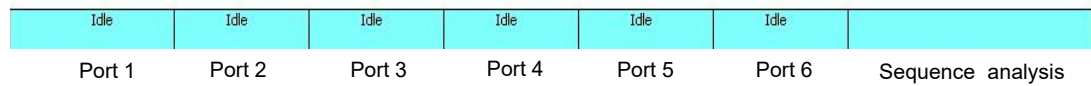

The status bar is separated into seven sections; one for each port and one (last section on the right side of the bar) for sequence analysis detail. This section will be blank for a standard sample analysis.

During sample preparation, the following steps are displayed:

Evacuation
Leak
Flow
Soak

During analysis, the following steps are displayed:

First analysis
Repeat evacuation
Repeat analysis
Free space evacuation
Free space

Termination displays when the analysis is complete and the furnace is being lowered and the sample cooled.

Idle displays when the port is completely idle (termination criteria are complete).

Show Instrument Schematic

Use to display a schematic of the ChemiSorb analyzer. The schematic is a graphical representation of the plumbing system including system valves, the analysis station, and the furnace position. The valves, furnace and MFC can be controlled from the schematic when Manual control is enabled. See the previous section for an explanation of the components displayed on the instrument schematic.

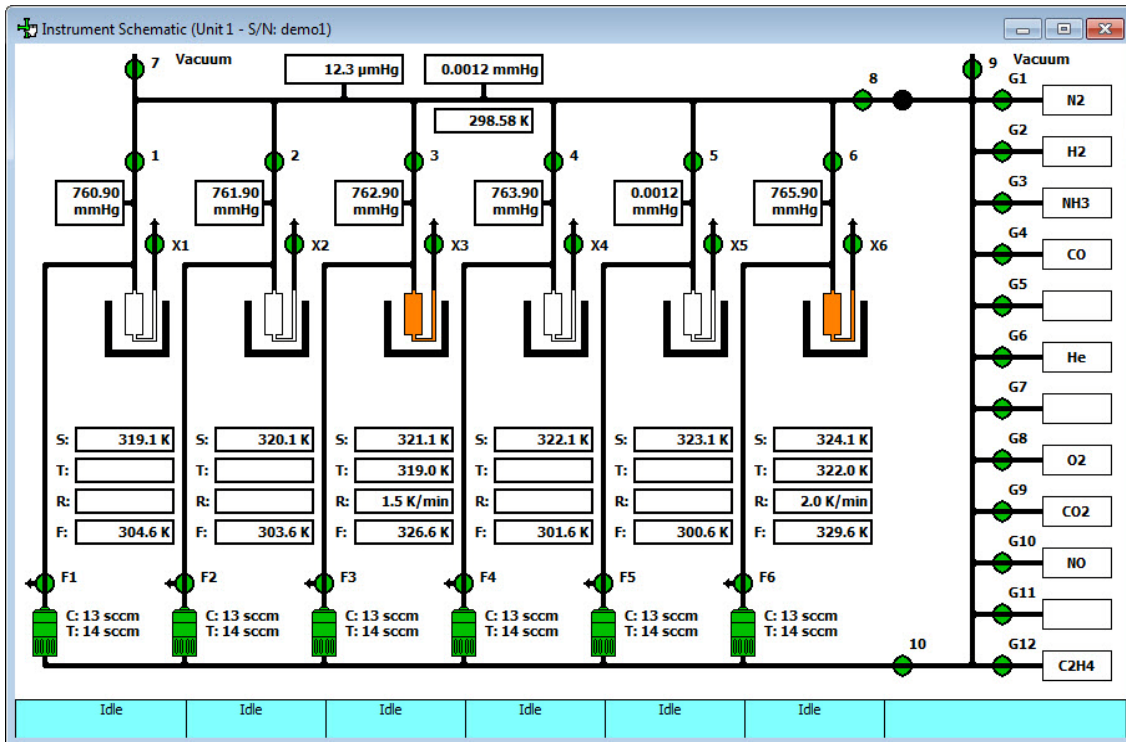

The state of the valves can be determined quickly by color representation even when manual control is not enabled:

- Green = open
- White = closed

To change the state of a valve, enable manual control first.

Show All Readings

This dialog shows the calibrated and nominal readings of all system sensors. This information can also be viewed from the analysis dialogs by selecting **All Readings** from the **View** drop-down list.

Manifold			
	Signal	Raw	
1000 mmHg:	760.90	772.46	mmHg
10 mmHg:	0.0012	0.8230	mmHg
Vacuum:	12	2	µmHg
Temperature:	298.6	309.7	K

Port 1			
	Signal	Raw	
1000 mmHg:	760.90	762.22	mmHg
10 mmHg:	100.0000	13.5510	mmHg
Sample:	319.1	320.3	K
Port:	306.5	307.6	K
Furnace:	304.6	K	
Target:	317.0	K	
Ramp Rate:	1.2	K/min	

Port 2			
	Signal	Raw	
1000 mmHg:	761.90	763.22	mmHg
10 mmHg:	100.0000	12.5510	mmHg
Sample:	320.1	321.3	K
Port:	307.5	308.6	K
Furnace:	303.6	K	
Target:	318.0	K	
Ramp Rate:	1.4	K/min	

Port 3			
	Signal	Raw	
1000 mmHg:	762.90	764.22	mmHg
10 mmHg:	100.0000	11.5510	mmHg
Sample:	321.1	322.3	K
Port:	308.5	309.6	K
Furnace:	326.6	K	
Target:	319.0	K	
Ramp Rate:	1.5	K/min	

Port 4			
	Signal	Raw	
1000 mmHg:	763.90	765.22	mmHg
10 mmHg:	100.0000	10.5510	mmHg
Sample:	322.1	323.3	K
Port:	309.5	310.6	K
Furnace:	301.6	K	
Target:	320.0	K	
Ramp Rate:	1.7	K/min	

Port 5			
	Signal	Raw	
1000 mmHg:	764.90	766.22	mmHg
10 mmHg:	0.0012	9.5510	mmHg
Sample:	323.1	324.3	K
Port:	310.5	311.6	K
Furnace:	300.6	K	
Target:	321.0	K	
Ramp Rate:	1.9	K/min	

Port 6			
	Signal	Raw	
1000 mmHg:	765.90	767.22	mmHg
10 mmHg:	100.0000	8.5510	mmHg
Sample:	324.1	325.3	K
Port:	311.5	312.6	K
Furnace:	329.6	K	
Target:	322.0	K	
Ramp Rate:	2.0	K/min	

Show Status

Use to view the current status of all six ports.

If two instruments are attached to the computer, the status bar for each instrument is displayed in a different color.

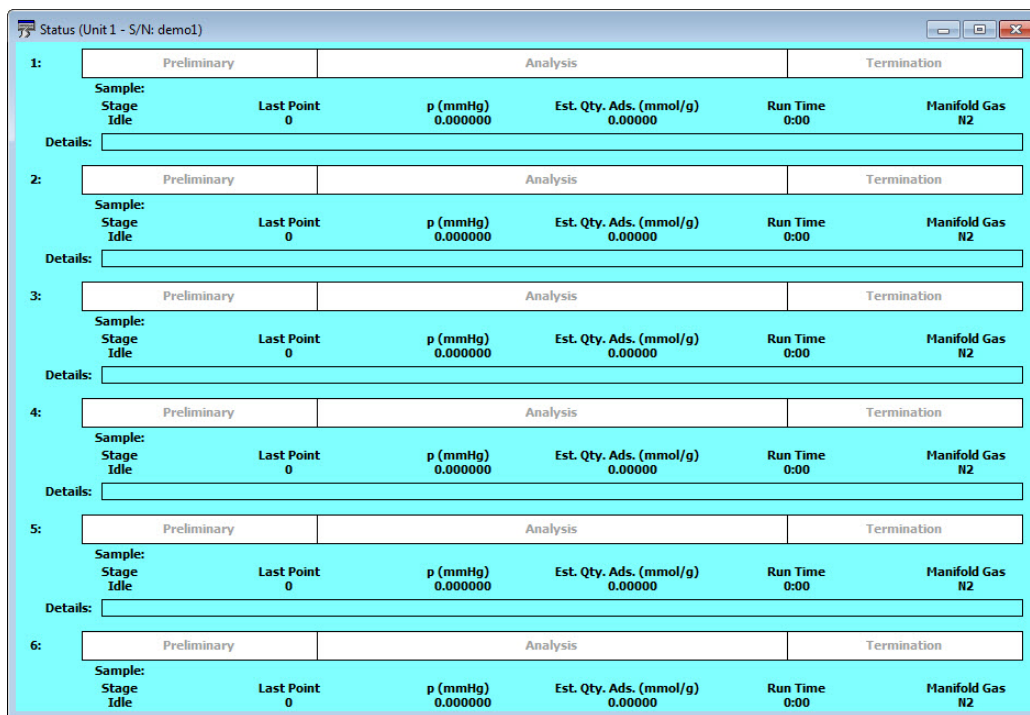

Analysis status bar

Shows the progression of the analysis. This bar contains three stages:

- **Preliminary:** sample is prepared; displays green during progression
- **Analysis:** data and free space are collected; displays blue during progression
- **Termination:** the furnace lowers, and the sample is cooled and backfilled; displays grey during progression

All stages are displayed in red if the analysis has been suspended.

Analysis details

The following analysis details are displayed:

Sample: Sample file number
Stage: Stage of the analysis (as in status bar)
Last Point: Last point and number of points requested
P: Pressure of last point
Est. Vol. Ads.: Volume adsorbed
Run Time: Elapsed time since the start of analysis
Manifold Gas: Current manifold gas

Step details

Provides details of the current step of the analysis.

Show Instrument Log

Displays a log of recent analyses, calibrations, and errors or messages. By default, this information is logged for a 7-day period for analyses and a 30-day period for messages and calibrations. Change the time this information is retained in the **Unit** section of the WIN2480.INI file.

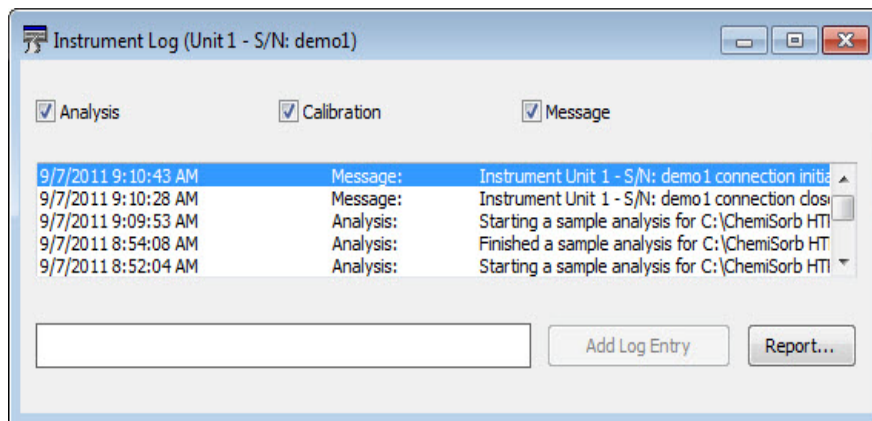

Analysis
Calibration
Messages

Use to select the type of entries displayed in the window. For example, select only the **Calibration** check box to display only calibration information.

Report

Use to generate the log contents to a specified destination; the Log Report Settings dialog is displayed.

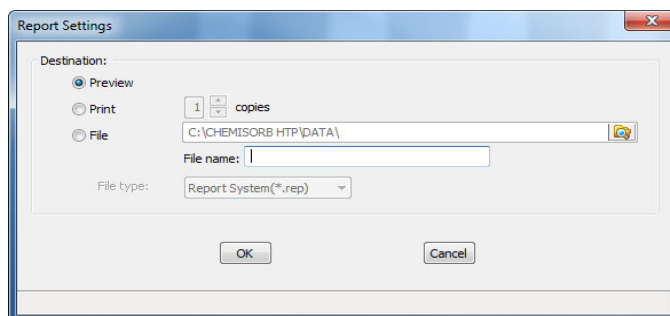

Destination

Use to select print options; print to the screen (**Preview**), to a printer, or to a file.

Preview prints the report to the screen.

Print sends the report to the default printer. Print up to 10 copies.

File - use to print and save the report as a file.

rep: system report which can be opened using the Open Report command on the Reports menu.

xls: spreadsheet format

txt: text file

The adjacent field displays the print destination. Use the **Browse** button to the right of the field to save the file in a different directory.

Unit Configuration

Use to view the current calibration settings, the date calibration was performed, and the software and hardware configuration of the system.

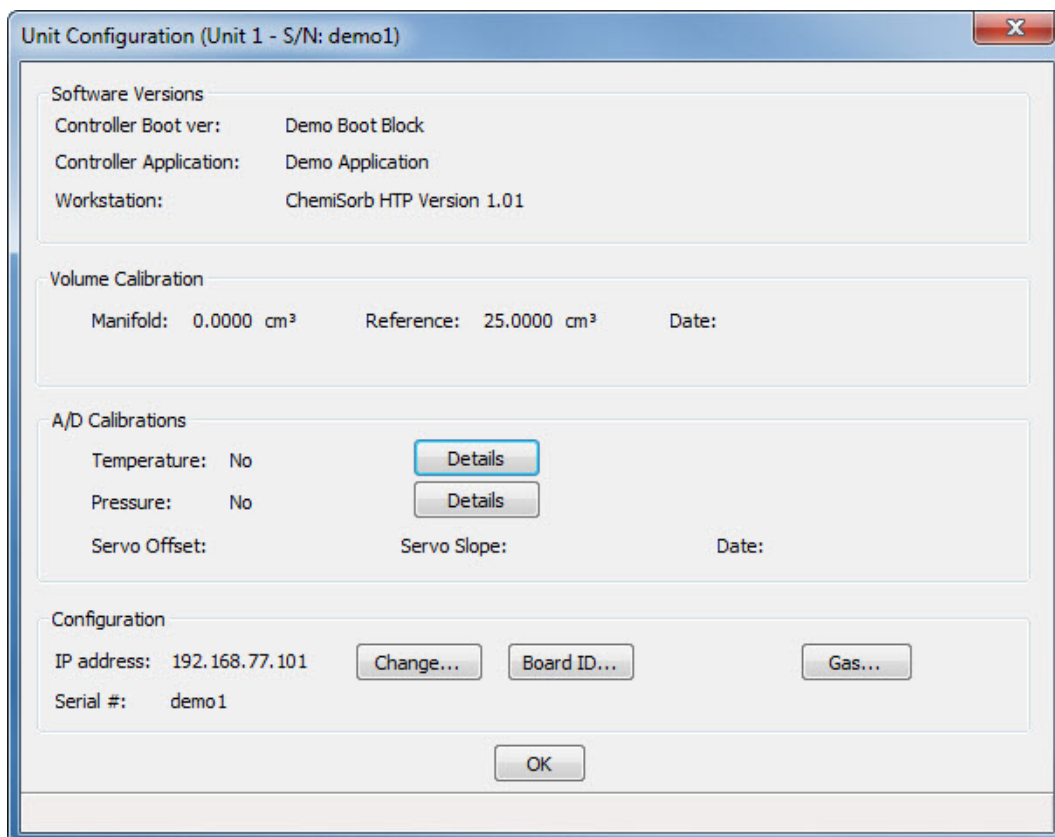

Software Versions	Displays the software versions being used by the analyzer.
Volume Calibration	Displays the manifold and reference volumes, and the date of calibration.
A/D Calibration	Click Details for Temperature and Pressure to display a dialog containing calibration details for each port.
Configuration	Displays the IP address used by the analysis program and the serial number of the selected analyzer. Use to view details of the boards installed in the analyzer and assign gas ports.

Change

Displays the Unit IP Setup dialog.

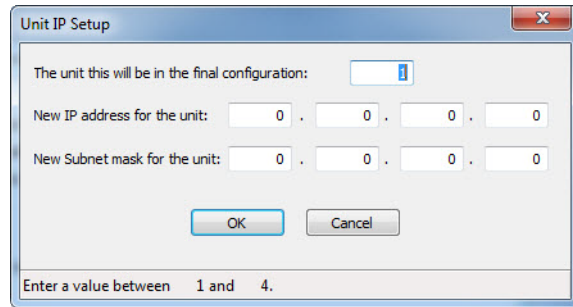

This dialog shows the IP address and Subnet mask that were assigned during installation. Do not edit these fields unless directed by a Micromeritics service representative.

Board ID

Displays the Board ID dialog showing the statistics of the board contained in the requested slot of the computer. For example, this dialog shows statistics of the backplane board.

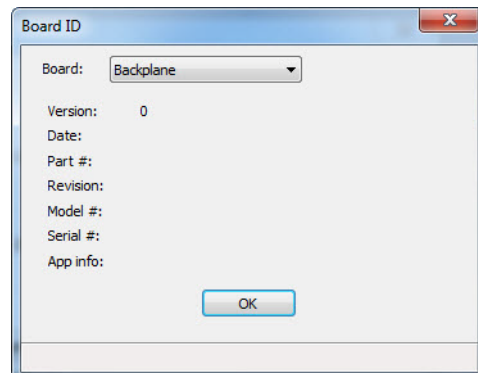
**Gas**

Displays the Gas Configuration dialog.

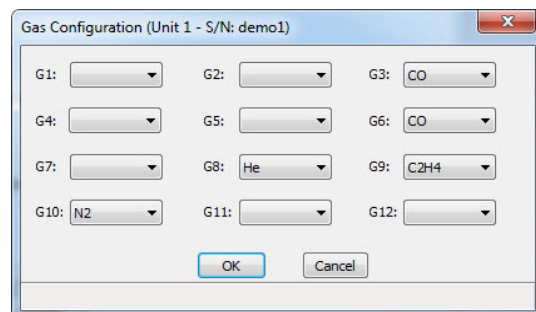

Use to select which gases are attached to each port of the analyzer.

Calibration

Use to perform system calibrations. Some calibrations are disabled and can be accessed only when using the Service Test Mode with the assistance of your service representative.

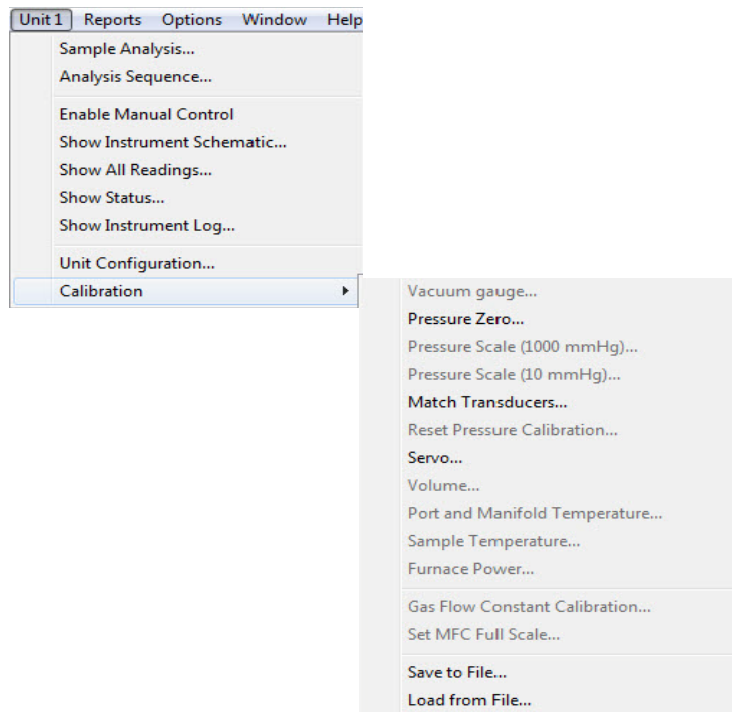

Pressure Zero

Use to evacuate the manifold and zero the selected transducers; the Calibrate Pressure Offset dialog is displayed.

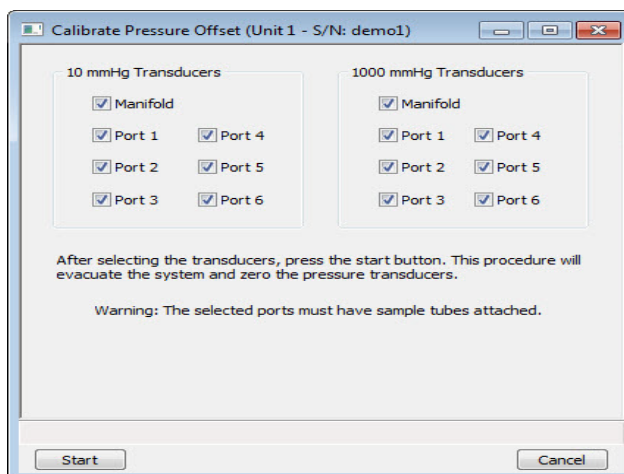

Select the transducer(s) to have offset to zero. Verify a sample tube is installed on the selected

ports. Click **Start**; a dialog indicating evacuation is in progress is displayed. When evacuation is complete, the dialog closes automatically.

Match Transducers

Use to zero and match the selected transducers to the main manifold transducer.

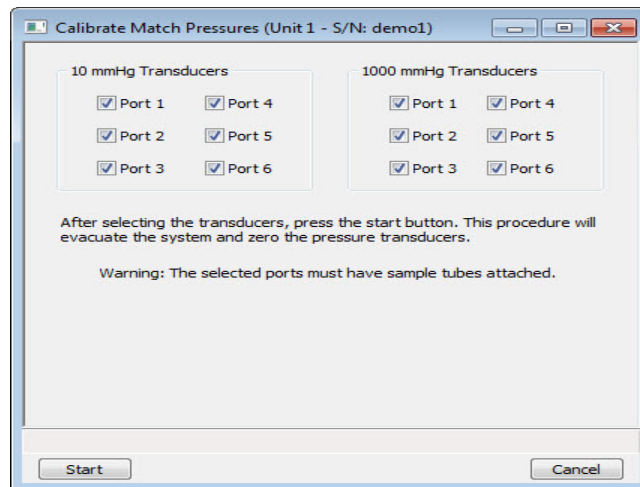

Select the transducer(s) to have matched. Be sure to install a sample tube on the selected ports. Click **Start**; a progress dialog is displayed. When the operation is complete, a confirmation dialog is displayed; click **OK** to close the dialog.

Servo

Use to calibrate the servo valve to the manifold pressure transducer. The servo valve should always be recalibrated after a pressure calibration has been performed. The Calibrate Servo dialog is displayed.

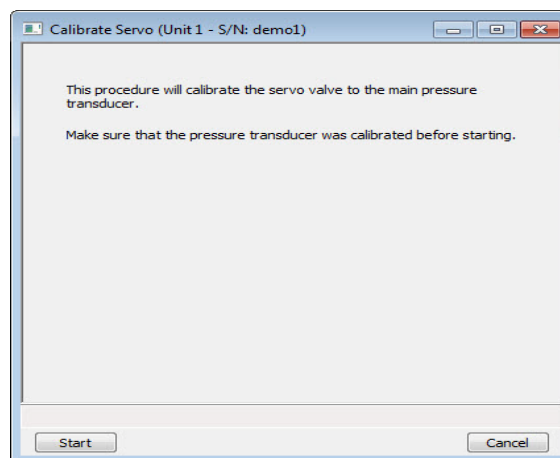

The only action required here is to click **Start**. The servo valve is then used to fill and equi-

brate the manifold, first to approximately 760 mmHg and then to approximately 50 mmHg. The pressure transducer readings (previously calibrated) at these points are used to calibrate the servo set point. Status messages are displayed during this procedure and a confirmation dialog is displayed when the operation is finished; click **OK** to close the dialog.

Save to File

Use to save the current calibration settings to a file that can be reloaded; the Select Calibration File dialog is displayed.

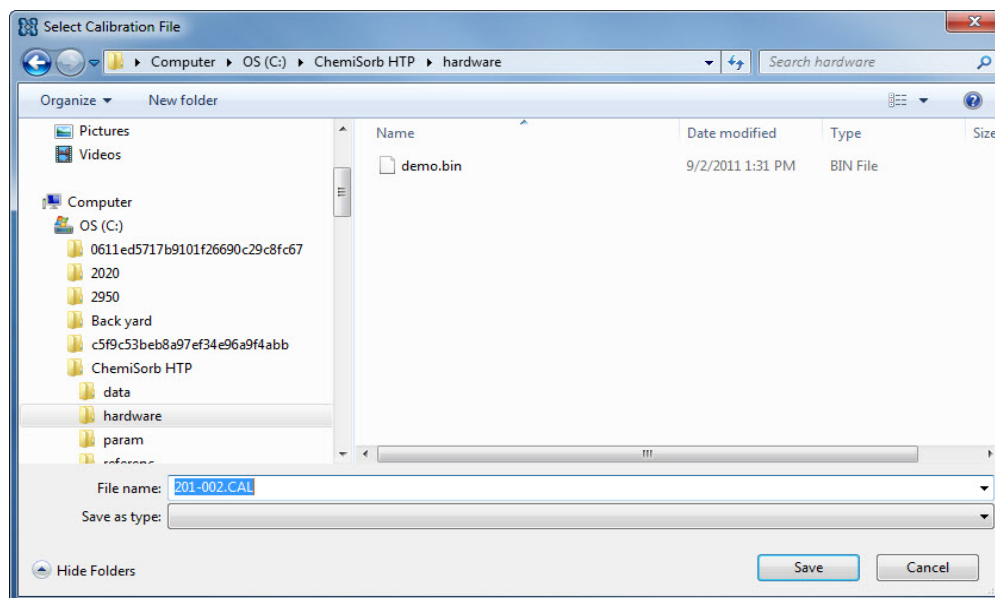

File name

The default for naming calibration files is the serial number, then the next sequenced number. For example in the dialog shown above, the number has defaulted to 201-002.CAL, where 201 represents the instrument serial number and 002 represents the second calibration file saved.

Enter a different name if necessary.

Load from File

Use to load a different calibration file. Select a file and click **Open**, a confirmation dialog is displayed; click **OK** to close the dialog.

It is recommended to save the current calibration settings using the **Save to File** command before loading another file.

7. REPORTS MENU

This chapter describes:

- how to start reports, page [7-2](#)
- how to close reports, page [7-4](#)
- how to open reports saved from the report window, page [7-4](#)
- how to generate Heat of Adsorption reports, page [7-5](#)
- the appearance of reports, page [7-9](#)
- manipulation tools for onscreen reports, page [7-9](#)

This chapter also contains examples of some of the reports available for the ChemiSorb analysis program beginning on page [7-18](#).

Reports can be generated for data:

- collected on a sample that has completed analysis
- collected on a sample that is currently being analyzed (includes only the information collected up to the time of the report)
- that are manually entered

Description

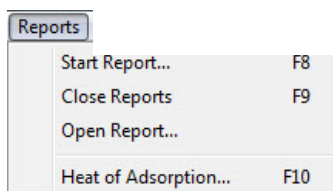

Listed below are brief descriptions of the commands contained on the Reports menu. Detailed descriptions follow this section.

Start Report

Use to generate a report on a completed sample analysis or on the data collected thus far for an analysis in progress. Page [7-2](#).

Close Reports

Closes all open report windows. Page [7-4](#).

- Open Report** Use to open a report that was saved from the report window. Page 7-4.
- Heat of Adsorption** Use to generate a heat of adsorption report. Page 7-5.

Start Report

Select to generate a report on a sample analysis; the Start Report dialog is displayed.

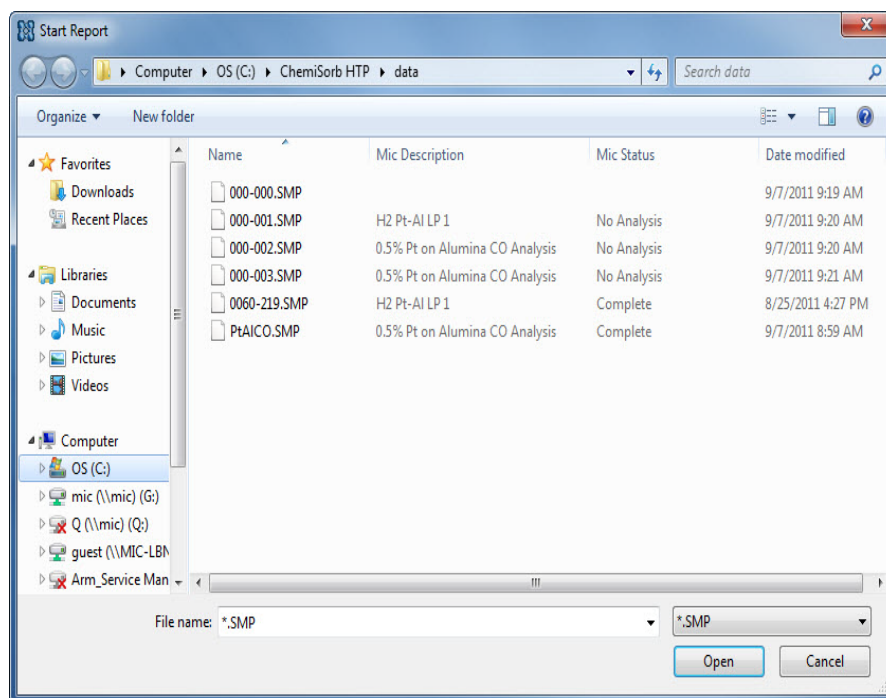

Files list This list contains the files located in the current directory.

File name The name of the file selected from the **Files** list is copied to this field.

Open

Displays the Report Settings dialog.

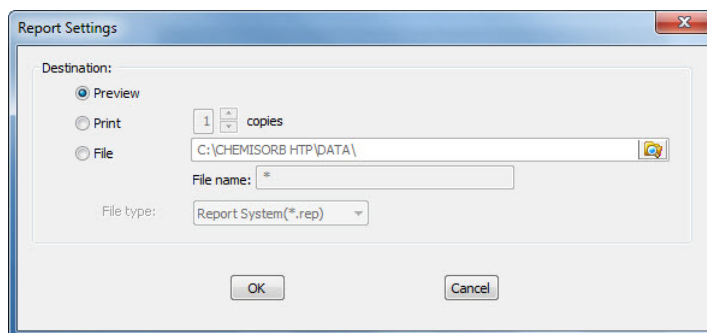

- **Preview:** prints file contents to the screen.
- **Print:** prints file contents to the default printer. Print up to 10 copies.
- **File:** prints file contents to a file. Enter a name in the **File name** field and select one of the following file types from the drop-down list:

rep: system report which can be opened using the Open Report command on the Reports menu.

xls: spreadsheet format

txt: text file

If a single file is selected, the following dialog is displayed.

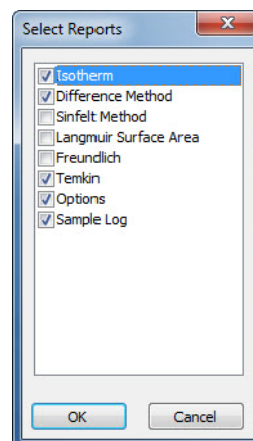

Use to confirm or edit the selection of the reports to generate.

Reports are selected when a check mark is in the box adjacent to the report name.

Close Reports

Use to close all open report windows at one time. This avoids having to select **Close** on each report window. This option is unavailable if reports are being generated.

Open Report

Use to open a report that was saved from the Report window; the Open dialog is displayed.

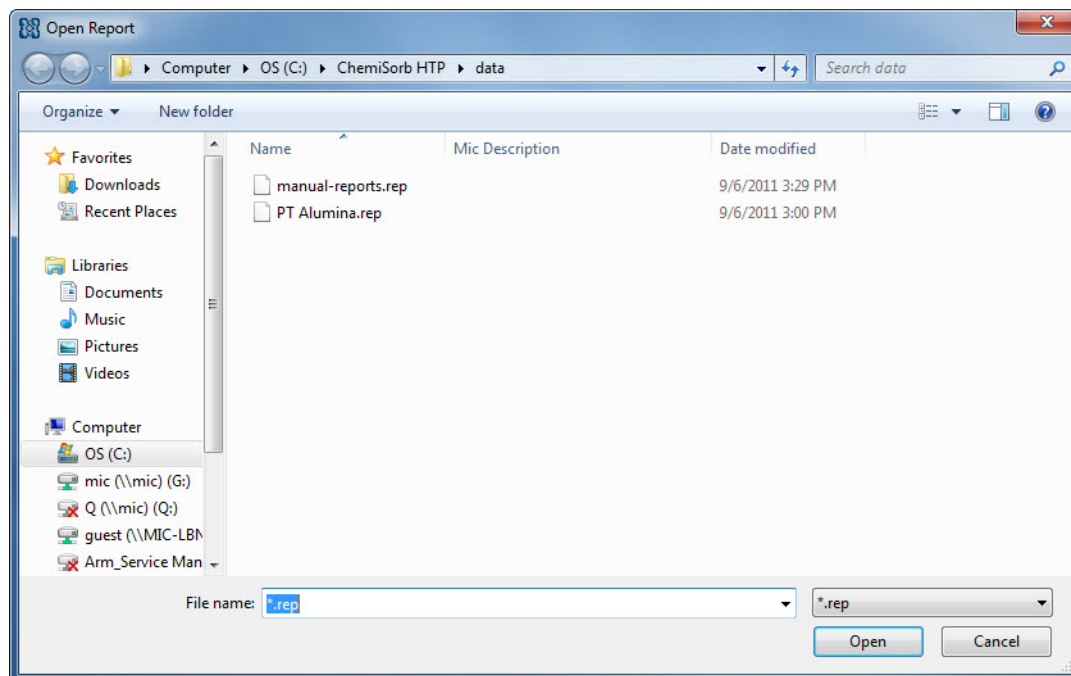

- | | |
|-------------------|---|
| Files list | This list contains the files located in the current directory. |
| File name | The name of the file selected from the Files list is copied to this field. |
| Open | Displays the selected report(s) in the Report window. |

Heat of Adsorption Report

The isosteric heat of adsorption is an important parameter for characterizing the surface heterogeneity and for providing information about the adsorbent and the adsorption capacity. Multiple adsorption isotherms are obtained on the same sample using the same adsorptive but at different temperatures to obtain the heat of adsorption.

Use to select the sample files, define the quantities, and generate a Heat of Adsorption report; the Heat of Adsorption dialog is displayed.

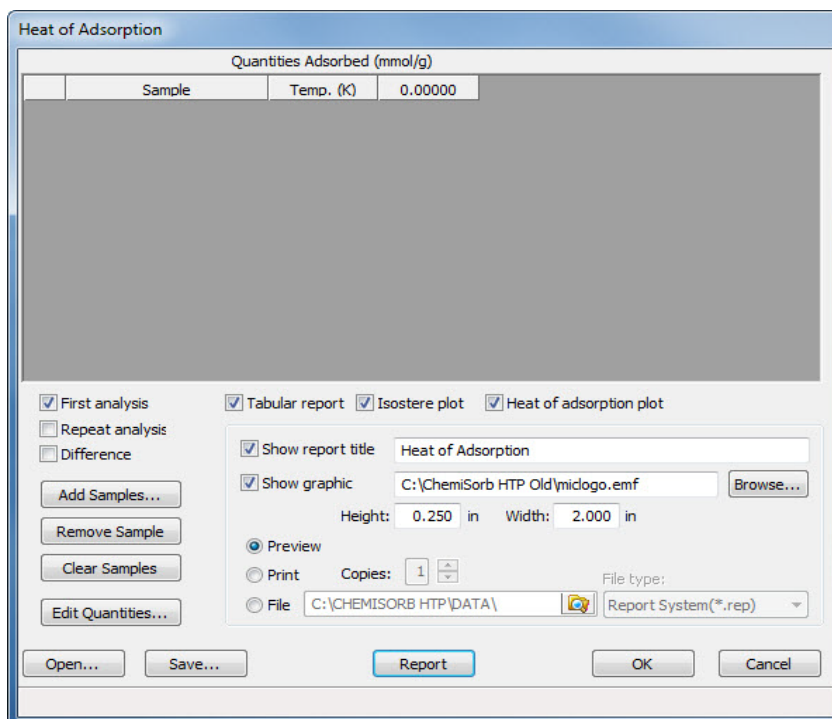

Table	Contains the selected files and lists the quantity adsorbed.
Analysis options	Use to select the analysis data to include. Include analysis data, repeat analysis (if requested in the files), and difference data.
Add Samples	Displays the Select Samples dialog to select files.
Remove Sample	Removes the selected sample file from the table. If a sample file is not selected, the first one is removed.

Clear Samples

Removes all sample files from the list.

Edit Quantities

Use to specify the range of surface coverage to include in the heat of adsorption report.

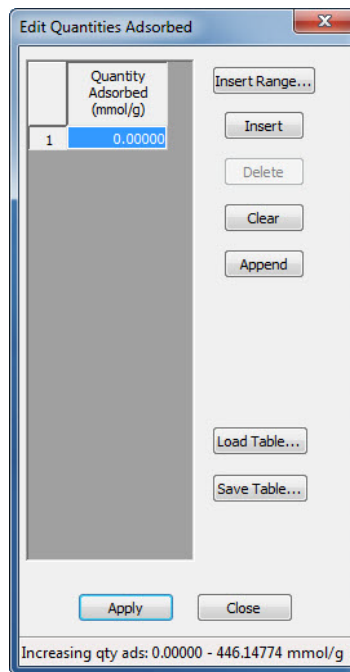
**Quantity Adsorbed table**

Use to enter the points.

Insert Range

Displays the Insert Quantity Range dialog.

Use to specify the starting and ending quantities adsorbed, as well as the number of points to insert within the specified range.

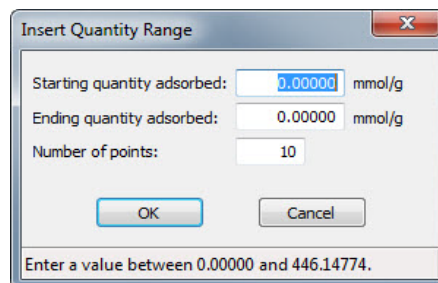
**Insert**

Inserts a row above the selected row.

Delete	Deletes the selected row.
Clear	Clears the entire table of all entries except one; one is required.
Append	Adds a row to the end of the table.
Load Table	Use to import a previously saved table.
Save Table	Use to save the current table as a file (QNT extension).
Tabular report	Use to have data generated in a tabular format.
Isostere plot	Use to generate a graph showing quantities of gas adsorbed vs. the temperature.
Heat of adsorption plot	Use to generate the Heat of Adsorption data in a graphical format.
Show report title	Use to have a title display in the header of a report; use the adjacent field to enter the title.
Show graphic	Use to have a graphic appear in the title - such as a company logo. Use either a bitmap or an enhanced metafile. Use the Height and Width fields to specify a size.
Preview	Prints the report to the screen. Use the report window to send the report to a printer.
Print	Prints the report to the default printer. Print up to 10 copies.

File	<p>Prints the reports to a file. Print as a:</p> <p>rep: system report which can be opened using the Open Report command on the Reports menu.</p> <p>xls: spreadsheet format</p> <p>txt: text file</p> <p>The adjacent field displays the print destination and a field to name the file. Use the Browse button to select a different directory.</p>
Open	Use to open a previously saved report.
Save	Saves the current report.
Report	Generates the report to the selected destination.

Printed Reports

Header

All reports contain a header displaying file and instrument statistics such as date and time of analysis, software version, analysis conditions, and so forth.

Report headers also contain notes of any changes to the sample file that occur after analysis.

Onscreen Reports

The report window containing onscreen reports provides many options for customizing and manipulating reports:

- a tool bar
- shortcut menus
- zoom feature
- axis cross hairs

When reports are printed to the screen, they are printed in a window like the one shown below. Each requested report is listed in the Reports window on the tool bar; they are also indicated by selectable tabs across the top of the report header. To view a specific report, select its tab or select the report in the Reports window and click **Show**.

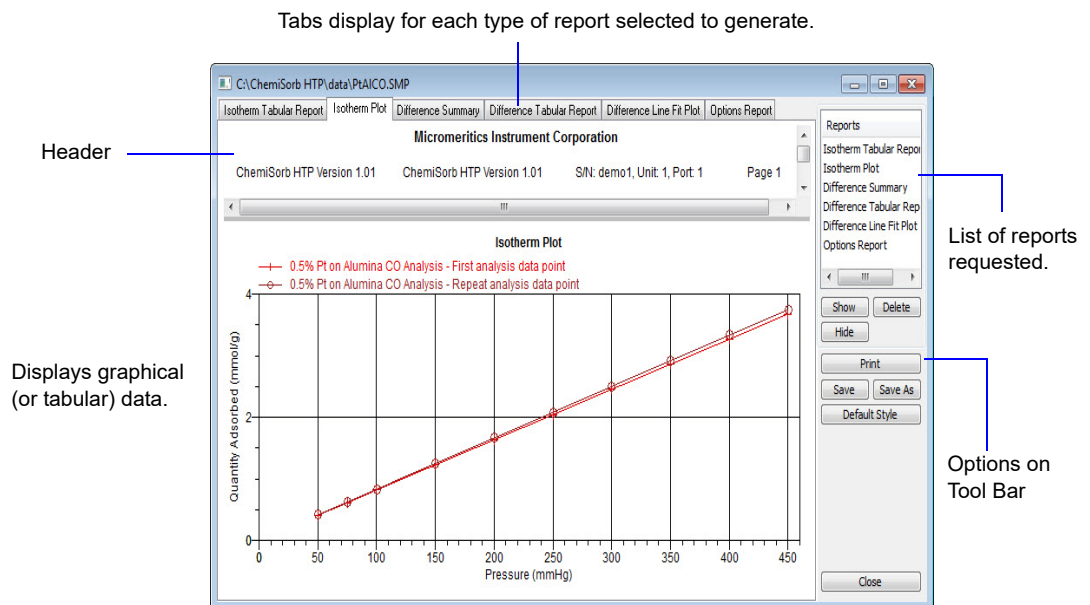

Tool Bar

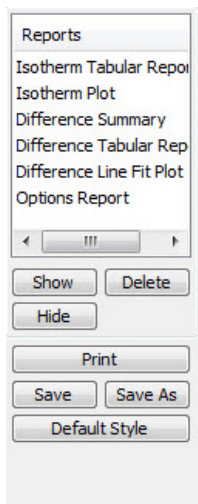

- | | |
|----------------|--|
| Reports | Contains a list of all requested reports. |
| Show | Shows the selected report in the report window. If the report has been hidden, it and its associated tab will become visible. |
| Delete | Deletes the selected reports. A deletion confirmation dialog is displayed since this function cannot be undone. The deleted report(s) will have to be regenerated if deleted in error. |
| Hide | Hides (removes) the selected report from the report window. The report's associated tab is also removed. |
| Print | Use to select an appropriate printer for report output. A list of available reports is displayed in the window on the right side of the dialog. |

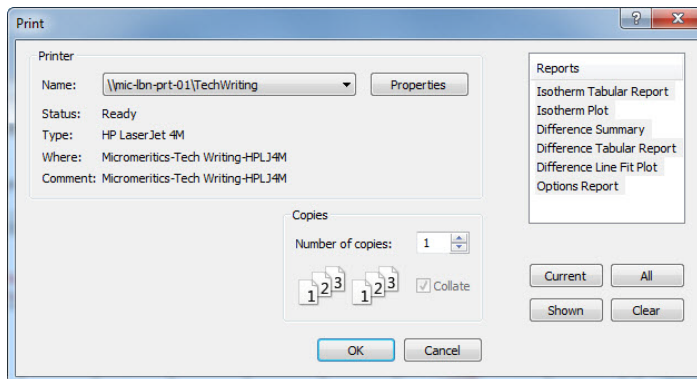

Print
(continued)

Use the buttons beneath the report window for report selection or make a selection by clicking the reports.

Current selects the report displayed in the report window.

Shown selects only the shown reports; any nonhighlighted reports indicate they are hidden. Select hidden reports from this window to print.

All selects all reports, including those that may have been hidden.

Clear clears all selections.

Save

Saves all reports of the currently open file in a report format using the same name as the sample file, only with an **rep** extension. To specify a name and/or specific reports to save, use the **Save As** button.

Save As

Saves all or specified reports from the currently open file. The buttons displayed on this dialog perform in the same manner as the print dialog (explained above).

Reports can be saved in three different formats:

Report system (*.rep): Saved in a format that can be reopened using the **Open Report** command on the Reports menu.

Spreadsheet (*.xls): Saved in a format which can be imported into most spreadsheet programs.

Ascii Text (*.txt): Saved in ASCII text which can be imported into programs accepting this type of file.

Default Style

Use to specify default parameters for report fonts and curve properties.

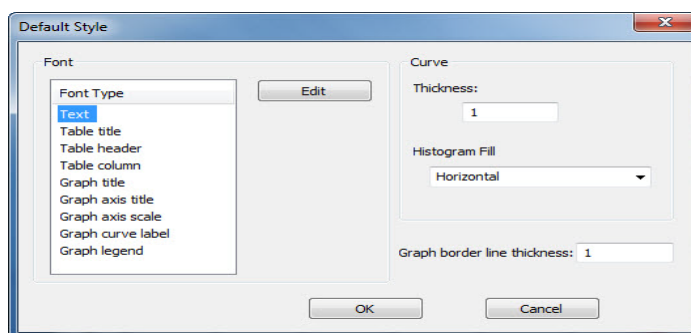
**Font**

Contains a list of report elements for which the font can be edited. Highlight the element and click **Edit**; a font dialog displays to specify the font and attributes.

Curve

Use to specify a thickness for report curves and, when using histograms, the type of fill to apply.

Graph border line thickness

Use to specify a thickness for the border of the graph.

Load

Loads the last saved defaults.

Save

Saves the changes as the defaults. Unsaved changes will apply to the current report set only. The next reports will revert to the defaults.

Close

Closes the Default Style dialog and applies the changes. Click **Save** to save the changes as defaults. Unsaved changes apply only to the current report set.

Close

Closes the report window.

Shortcut Menus

Shortcut menus are accessed by right-clicking the tabular or graphical portion of a report.

Tabular Reports

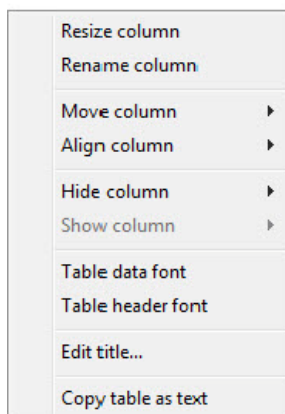

Resize column	Use to specify the width (in inches) of the selected column.
Rename column	Use to edit the name of the selected column. Use Ctrl + Enter to insert line feeds.
Move column	Use to move the location of the selected column to the left or to the right.
Align column	Use to right-align, left-align, or center the data in the selected column.
Hide column	Use to select columns to hide.
Show column	Use to display a list of all hidden columns. Select the columns to show.
Column font	Use to display a Font dialog for changing font attributes for the tabular data in the current report.
Header font	Use to display a Font dialog for changing font attributes for column headers in the current report.

Edit title	Use to edit the table title and font.
Copy table as text	Use to copy the entire table (column headers and data) and then insert it into another program. Columns are tab-delimited for easy alignment.

Graphs

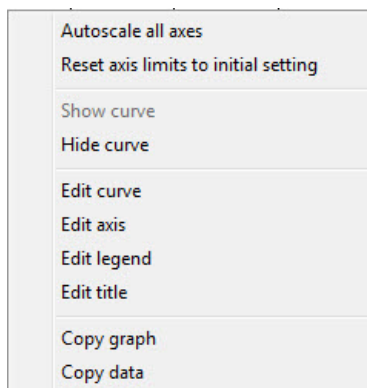

Autoscale	Autoscales all axes of the graph. This function is useful for returning to a full view after having zoomed in.
Redraw	Sets axis boundaries to its original view. Use this function to remove cross-hairs.
Show curve	Shows any curve that has been hidden. This option is disabled (greyed) if no curves have been hidden.
Hide curve	Hides (removes from view) any unwanted curve.

Edit curve

Use to edit curve properties.

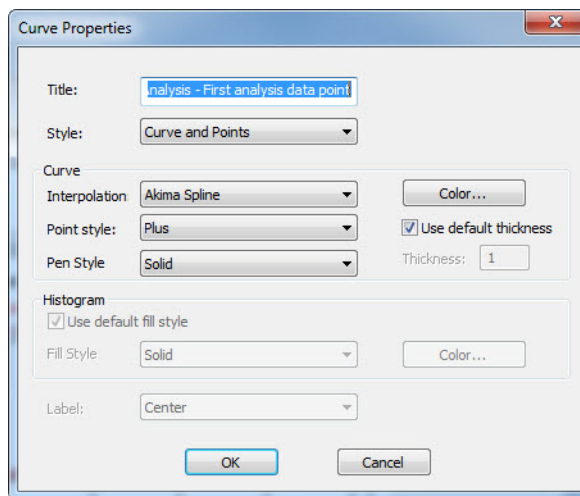
**Title**

Displays the title of the curve being edited.

Style

Drop-down list containing styles in which collected data can be displayed.

*Choices: Curve, Histogram, Points, Curve and Points***Curve group box**

Contains options for curves and points. Edit the curve interpolation, the style of curve and/or points, the thickness of the pen, and the pen color.

These options are disabled if Histogram is chosen in the **Style** drop-down list.**Histogram group box**

Use to specify the type of fill as well as the color if Histogram is chosen as the style for collected data.

Edit axis

Use to edit axis properties.

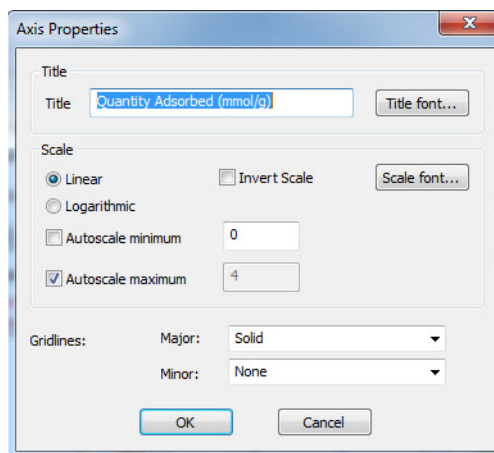
**Edit legend**

Use to edit the placement of the legend.

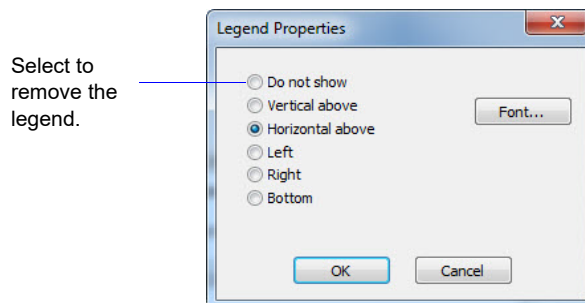
**Edit title**

Use to edit the current graph's title and font.

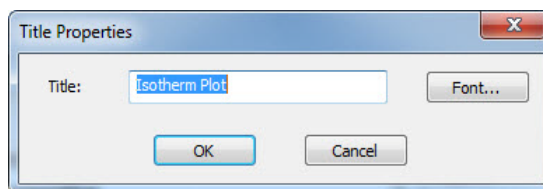
**Copy Graph**

Use to copy the graph and places it on the clipboard, for pasting into another application.

Copy Data

Copies the data used to generate the graph as a series of tab-delimited columns of text.

Zoom Feature

A zoom feature is included with the report system to zoom in to examine fine details. To use this feature, hold down the left mouse button and drag the mouse cursor (drawing a box) across the area to view; then release the button. The enlarged area immediately fills the graph area. Right-click in the graph area and select **Reset** or **Autoscale** from the shortcut menu to return to the normal view.

Axis Cross Hair

A cross-hair function is available to view axis coordinates. To use this feature, left-click in the area of the graph.

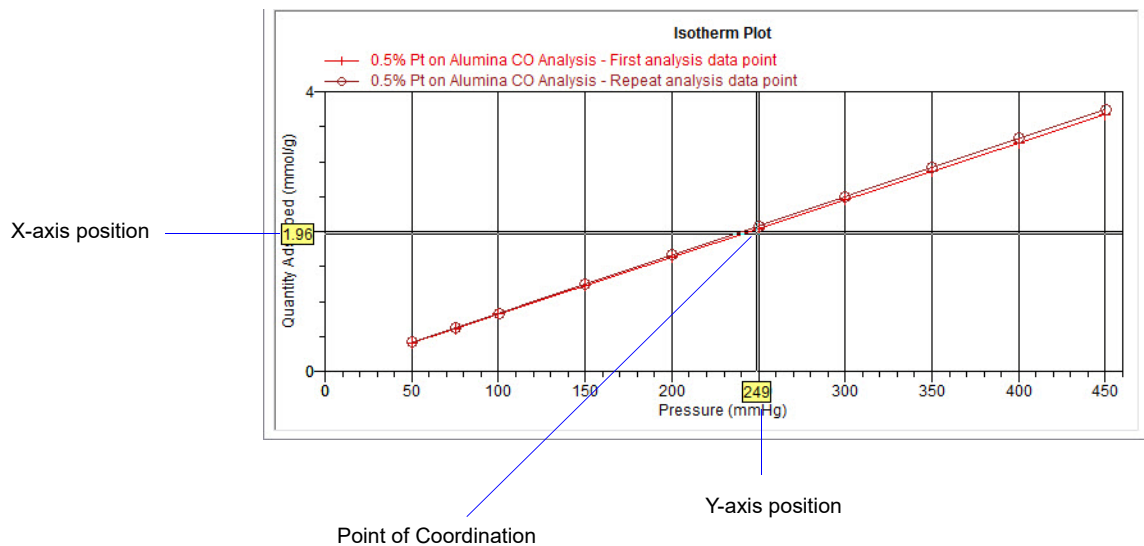

Right-click in the graph area and select **Reset** or **Autoscale** from the shortcut menu to remove cross-hair lines and return to the normal view. Alternatively, click outside of the graph area.

Report Examples

The remainder of this section contains samples of some of the reports which may be generated by the ChemiSorb program. Most of the reports can be varied through entries on the report options screens.

Isotherm

Plot

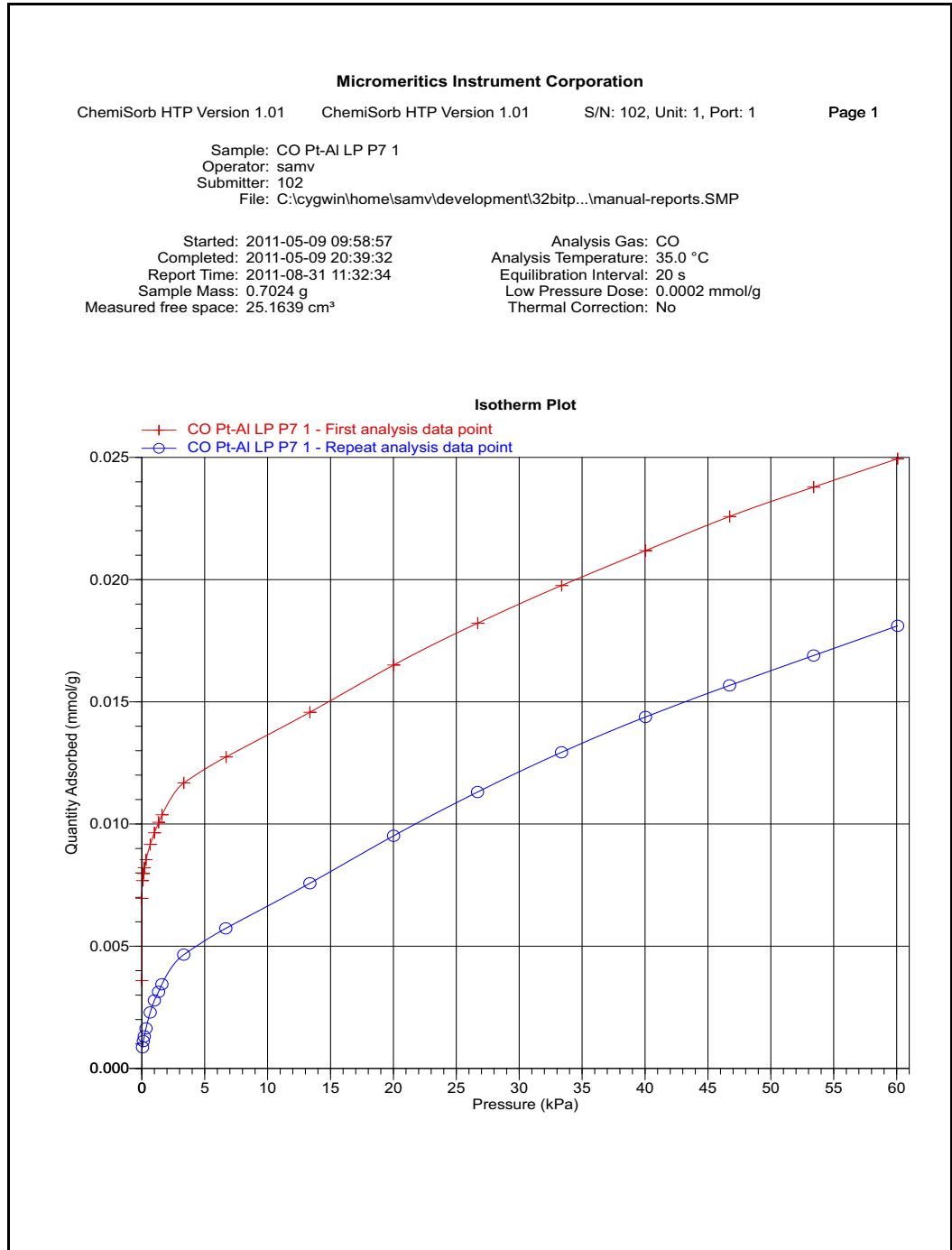

Tabular Report

Micromeritics Instrument Corporation

ChemiSorb HTP Version 1.01

ChemiSorb HTP Version 1.01

S/N: 102, Unit: 1, Port: 1

Page 1

Sample: CO Pt-AI LP P7 1

Operator: samv

Submitter: 102

File: C:\cygwin\home\samv\development\32bitp...\manual-reports.SMP

Started: 2011-05-09 09:58:57

Completed: 2011-05-09 20:39:32

Report Time: 2011-08-31 11:32:34

Sample Mass: 0.7024 g

Measured free space: 25.1639 cm³

Analysis Gas: CO

Analysis Temperature: 35.0 °C

Equilibration Interval: 20 s

Low Pressure Dose: 0.0002 mmol/g

Thermal Correction: No

Isotherm Tabular Report

Analysis Data

Pressure (kPa)	Quantity Adsorbed (mmol/g)	Time (hh:mm)	Repeat Pressure (kPa)	Repeat Quantity Adsorbed (mmol/g)	Time (hh:mm)
0.00113	0.00360	00:05			
0.00284	0.00696	00:15			
0.05989	0.00768	00:30	0.05584	0.00086	03:16
0.12746	0.00798	00:38	0.12432	0.00112	03:22
0.20052	0.00821	00:43	0.19393	0.00131	03:28
0.33005	0.00854	00:49	0.33408	0.00164	03:34
0.66666	0.00916	00:54	0.66436	0.00229	03:40
1.00321	0.00964	00:58	0.99872	0.00278	03:45
1.33681	0.01007	01:01	1.32911	0.00313	03:49
1.60555	0.01038	01:07	1.59504	0.00344	03:54
3.33678	0.01168	01:11	3.32824	0.00465	03:58
6.69795	0.01275	01:15	6.67819	0.00573	04:02
13.36156	0.01457	01:20	13.35568	0.00758	04:06
20.02378	0.01651	01:24	20.01299	0.00952	04:10
26.69877	0.01822	01:28	26.68701	0.01131	04:14
33.37028	0.01976	01:33	33.36202	0.01293	04:18
40.04853	0.02119	01:38	40.03775	0.01438	04:22
46.72648	0.02258	01:43	46.71710	0.01567	04:26
53.40162	0.02379	01:48	53.39798	0.01689	04:30
60.07649	0.02494	01:53	60.07578	0.01811	04:35

Difference Method

Summary

Micromeritics Instrument Corporation

ChemiSorb HTP Version 1.01 ChemiSorb HTP Version 1.01 S/N: 102, Unit: 1, Port: 1 Page 1

Sample: CO Pt-Al LP P7 1
 Operator: samv
 Submitter: 102
 File: C:\cygwin\home\samv\development\32bitp...\manual-reports.SMP

Started: 2011-05-09 09:58:57 Analysis Gas: CO
 Completed: 2011-05-09 20:39:32 Analysis Temperature: 35.0 °C
 Report Time: 2011-08-31 11:32:34 Equilibration Interval: 20 s
 Sample Mass: 0.7024 g Low Pressure Dose: 0.0002 mmol/g
 Measured free space: 25.1639 cm³ Thermal Correction: No

Difference Summary

Element	Percent of Sample Weight (%)	Percent Reduced (%)	MxOy,X	MxOy,Y	Atomic Weight	Stoichiometry Factor	Atomic Cross-Sectional Area (nm ²)	Density (g/cm ³)
platinum	0.50	100.00	1	0	195.090	1.000	0.0800	21.450

Analysis Results

Metal Dispersion: 47.2394 %
 Metallic Surface Area: 0.5834 m²/(g of sample)
 Metallic Surface Area: 116.6734 m²/(g of metal)
 Crystallite Size (6.000 V / A): 2.39746 nm
 Y-Intercept Quantity Adsorbed: 0.01211 ± 0.00030 mmol/g
 Slope: 0.000658 ± 0.000023
 Correlation Coefficient: 0.996511

Difference Results

Metal Dispersion: 27.3088 %
 Metallic Surface Area: 0.3372 m²/(g of sample)
 Metallic Surface Area: 67.4483 m²/(g of metal)
 Crystallite Size (6.000 V / A): 4.14718 nm
 Y-Intercept Quantity Adsorbed: 0.00700 ± 0.00005 mmol/g
 Slope: -0.000008 ± 0.000004
 Correlation Coefficient: -0.657288

Plot

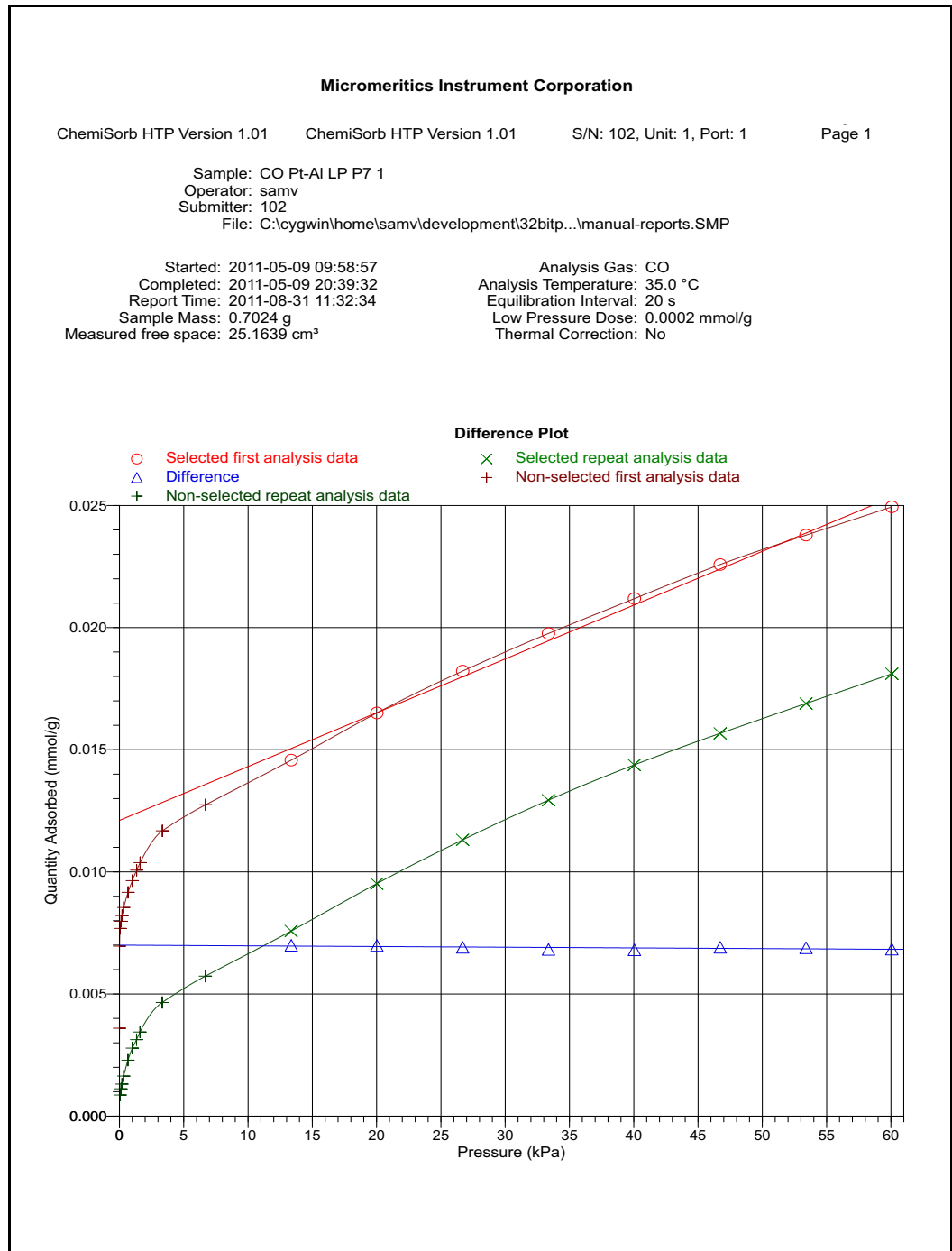

Sinfelt Method

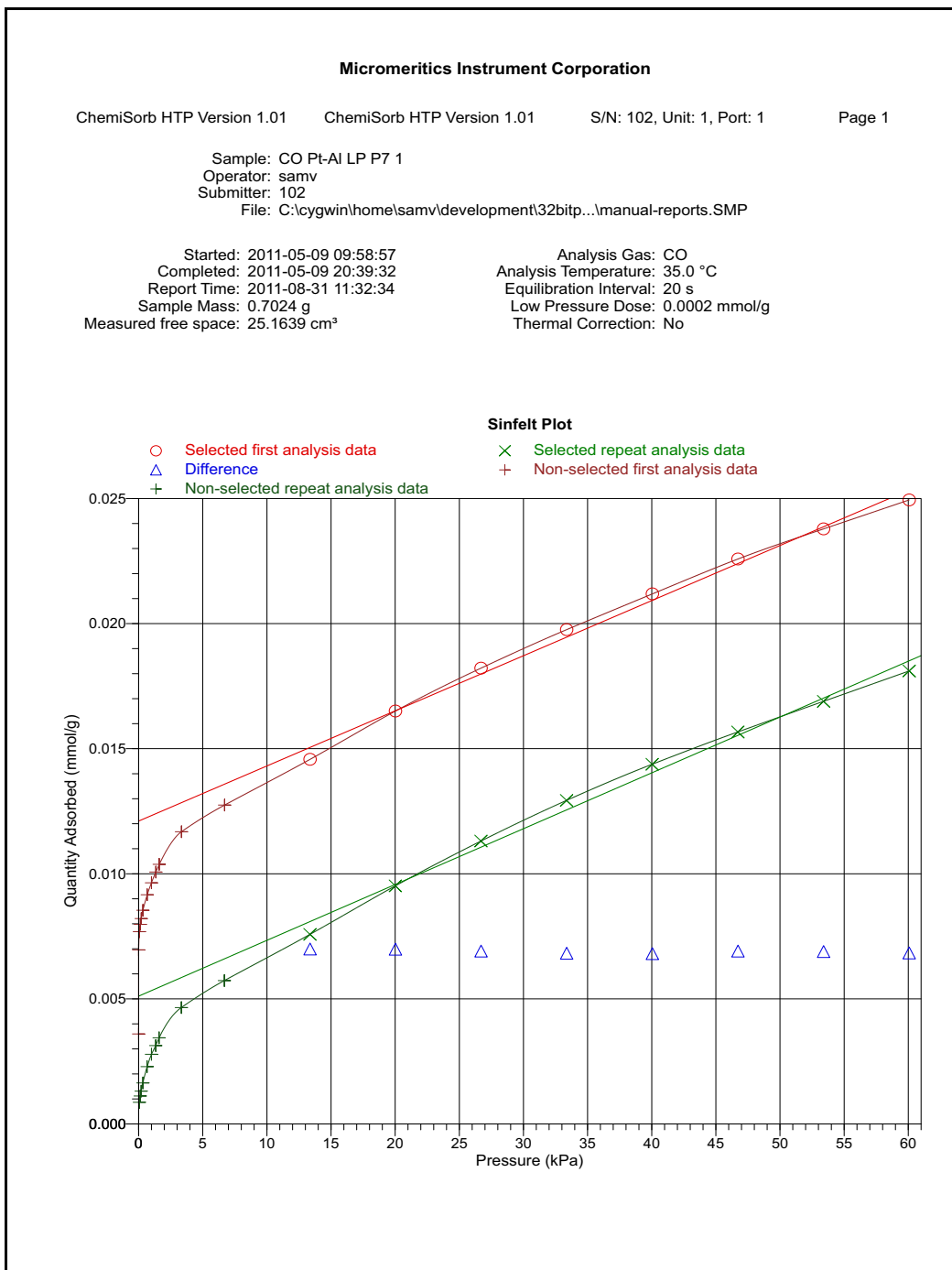

Langmuir Surface Area

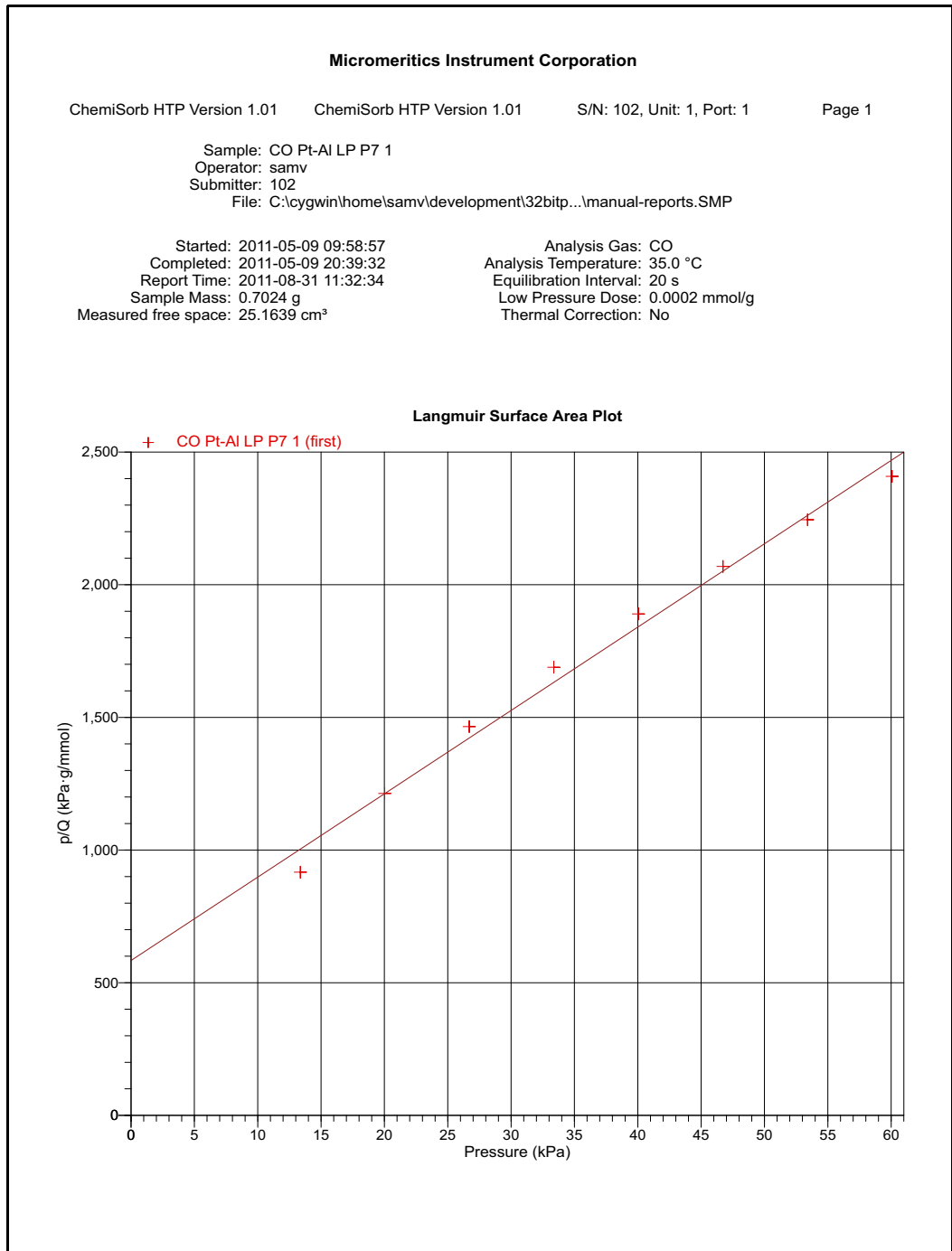

Options Report

Page 1

Micromeritics Instrument Corporation

ChemiSorb HTP Version 1.01 ChemiSorb HTP Version 1.01 S/N: 102, Unit: 1, Port: 1 Page 1

Sample: CO Pt-AI LP P7 1
 Operator: samv
 Submitter: 102
 File: C:\cygwin\home\samv\development\32bit...\manual-reports.SMP

Started: 2011-05-09 09:58:57 Analysis Gas: CO
 Completed: 2011-05-09 20:39:32 Analysis Temperature: 35.0 °C
 Report Time: 2011-08-31 11:32:34 Equilibration Interval: 20 s
 Sample Mass: 0.7024 g Low Pressure Dose: 0.0002 mmol/g
 Measured free space: 25.1639 cm³ Thermal Correction: No

Options Report

Task Summary

Task Number	Task Name	Gas	Temperature (°C)	Rate (°C/min)	Time (min)	Pressure (kPa)	Flow Rate (sccm)
1	Evacuation		110.0	10.0	30		
2	Flow	H2	100.0	10.0	10		50.0
3	Flow	H2	400.0	10.0	30		50.0
4	Evacuation		400.0	10.0	30		
5	Evacuation		35.0	100.0	60		
6	Leak Test		35.0	10.0			
7	Evacuation		35.0	10.0	20		
8	Analysis	CO	35.0	10.0			

Task Number: 8
 Adsorptive: Carbon Monoxide
 Temperature: 35.0 °C
 Heat rate: 10.0 °C/min
 Relative target tolerance: 5.0 %
 Absolute target tolerance: 0.6666 kPa
 Use maximum volume increment: No
 Incremental dosing: Yes
 Dose amount: 0.0002 mmol/g
 Repeat analysis: Yes
 Evacuation rate: 6.67 kPa/s
 Unrestricted evac. from: 4.00 kPa
 Evacuate for 60 minutes below 1.3 Pa.

Free space group: Measured
 Evacuation rate: 6.67 kPa/s
 Unrestricted evac. from: 4.00 kPa
 Evacuate for 60 minutes below 1.3 Pa.
 Estimated free space: 25.0000 cm³

Equilibration

Pressure (kPa)	Equilibration Interval (s)
119.9901600	20

Experiment Log

Task Number	Task Name	Start Time (h:min)	Gas	Sample Temp. (°C)	Time (min)	Pressure (kPa)
1	EVAC	0:03		109.9	40	
2	FLOW	0:44	H2	98.3	12	739.71576
3	FLOW	0:56	H2	400.2	60	739.61572
4	EVAC	1:56		400.0	45	

Page 2

Micromeritics Instrument Corporation

ChemiSorb HTP Version 1.01 ChemiSorb HTP Version 1.01 S/N: 102, Unit: 1, Port: 1 Page 2

Sample: CO Pt-AI LP P7 1
 Operator: samv
 Submitter: 102
 File: C:\cygwin\home\samv\development\32bitp...\manual-reports.SMP

Started: 2011-05-09 09:58:57 Analysis Gas: CO
 Completed: 2011-05-09 20:39:32 Analysis Temperature: 35.0 °C
 Report Time: 2011-08-31 11:32:34 Equilibration Interval: 20 s
 Sample Mass: 0.7024 g Low Pressure Dose: 0.0002 mmol/g
 Measured free space: 25.1639 cm³ Thermal Correction: No

Experiment Log

Task Number	Task Name	Start Time (h:min)	Gas	Sample Temp. (°C)	Time (min)	Pressure (kPa)
5	EVAC	2:41		35.2	107	
6	LEAK	4:29		35.1	0	0.03048
7	EVAC	4:29		35.1	20	
8	ANL	4:55	CO	35.0	275	

Leak Test Results

Start Time (min)	Maximum Allowed Outgas Rate (Pa/min)	Observed Outgas Rate (Pa/min)	Status
4:29	1.3	0.06	Pass

8. OPTIONS MENU

Use to configure the system to your laboratory's requirements and specify defaults for sample and parameter files.

Description

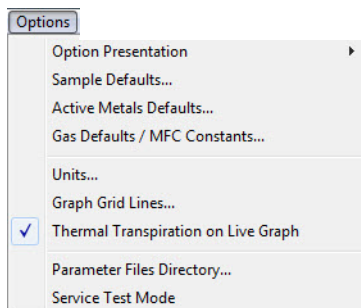

Option Presentation	Use to display the sample file dialog in Advanced, Basic, or Restricted format. Page 8-2 .
Sample Defaults	Use to specify default values for sample and parameter files. Page 8-6 .
Active Metals Defaults	Use to specify options for the chemisorption elements. Page 8-12 .
Gas Defaults MFC Constants	Use to specify options for the adsorptives. Page 8-14 .
Units	Use to select the types of units to use for measurement, pressure, and temperature. Page 8-16 .
Graph Grid Lines	Use to select the types of grid lines to display for the X- and Y-axes. Page 8-16 .
Thermal Transpiration on Live Graph	Use to apply thermal transpiration to the current graph. Page 8-17 .

Parameter Files Directory	Use to specify a location for the parameter files used in the Basic and Restricted sample file dialogs. Page 8-17 .
Service Test Mode	Use to perform certain troubleshooting procedures. This option is available only under the direction of a Micromeritics service representative. Page 8-17 .

Option Presentation

The sample editing dialogs for the ChemiSorb HTP analysis program may be presented in three modes: Restricted, Basic, and Advanced.

Each format displays sample information and menu options differently.

- **Advanced:** displays all parts of the sample information file in a tabbed dialog similar to that of an index card file.
- **Basic:** displays all parameters of the sample file in a single dialog.
- **Restricted:** displays in the same manner as the Basic format, except that some options are disabled.

Advanced

The Advanced format presents all parts of the sample information file in a tabbed dialog. Each tab opens its associated dialog. For example, to open or create a sample file using the Advanced format, the following dialog is displayed.

The screenshot shows a dialog box titled "C:\ChemiSorb HTP\data\000-002.SMP" with three tabs: "Sample Information", "Analysis Conditions", and "Report Options". The "Sample Information" tab is selected. It contains the following fields and options:

- Sample:
- Operator:
- Submitter:
- Bar Code:
- Mass section with two radio buttons: "Enter" (selected) and "Calculate".
 - Under "Enter": Sample Mass: g
 - Under "Calculate": Sample + tube: g; Empty tube: g and g
- Type of Data section with two radio buttons: "Automatically collected" (selected) and "Manually entered". A "Replace all..." button is located to the right of the "Manually entered" option.
- Comments:
- "Add log entry..." button

At the bottom of the dialog are buttons for "Save", "Close", a dropdown menu currently set to "Advanced", and "Preview".

If Manually entered data is selected, an Entered Data tab also displays.

If Automatically collected is selected, a Collected Data tab displays after analysis.

The Advanced format is used to create customized sample files and edit values in parameter files. Switch to the Basic format by clicking the down arrow next to **Advanced** and selecting **Basic**. See [Advanced Format](#), page 5-5.

Basic

The Basic format presents the sample information file and its parameter files as a single dialog. For example, to open or create a sample information file using the Basic format, the dialog is displayed in this manner.

The screenshot shows a dialog box titled "C:\ChemiSorb HTP\data\000-002.SMP". It contains the following fields and controls:

- Sample:
- Operator:
- Mass section with two radio buttons: Enter and Calculate.
- Sample Mass: g
- Sample + tube: g
- Empty tube: g and g
- Analysis Conditions:
- Report Options:
- Buttons: Replace all..., Add log entry...
- Bottom bar: Save, Close, Basic (dropdown), Preview

The Basic format is used to quickly create sample information files using previously defined parameter files. Switch to Advanced format by clicking the down arrow next to **Basic** and selecting **Advanced**. See [Basic Format](#), page [5-8](#).

Restricted

The Restricted format is identical to the Basic format, except that certain options are disabled and the user cannot switch to the Advanced format.

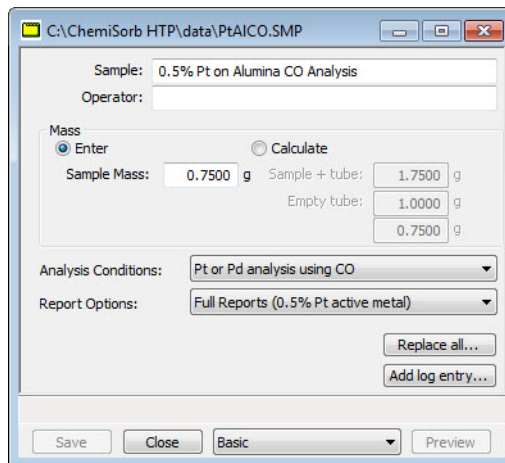

This format is password-protected and is typically used in laboratories where analysis conditions must remain constant, for example, in the pharmaceutical industry.

When Restricted is selected, a dialog prompting for a password is displayed.

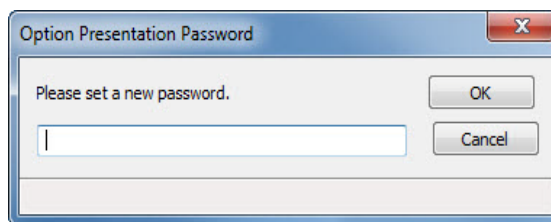

Enter any password (up to 31 characters) to enable the Restricted format. Use the same password exit the Restricted format. For example, if the password entered is "password" to enable the Restricted format, then "password" must be entered to exit. If the password is forgotten, open the system INI file and navigate to the Private section. The current password is shown immediately following "OptionPresentationPassword." Make a note of the password, exit the INI file, and enter the password where requested. Deleting the password from the INI file will not disable the Restricted mode. The password must be used to exit the Restricted format.

Sample Defaults

Use to specify default parameters for sample information files. This option is presented in two formats: **Advanced** and **Basic**. Select **Options > Option presentation** to select the format to use. Alternatively, switch between the two formats using the **Advanced / Basic** button displayed on the lower right side of the dialog.

Advanced

The Advanced Sample Defaults dialog resembles a set of index cards. The values specified in the parameter portions of the sample file (Analysis Conditions and Report Options) are saved as the defaults for newly created parameter files.

For example, after specifying defaults for a sample file in the Advanced format:

- Select **File > Open > Sample Information**, then click **Yes** to create the file and the defaults display for all parameters.
- Select **File > Open > Analysis Conditions**, name and create the file, and the default specified in the Analysis Conditions portion of the Advanced Sample Defaults dialog display in the fields

The Advanced Sample Defaults dialog displays in this manner:

C:\ChemiSorb HTP\2480.SMP

Sample Information Analysis Conditions Report Options

Sequence: 000-000

Sample: \$

Operator: Omit

Submitter: Omit

Bar Code: Omit

Mass

Enter Calculate

Sample Mass: 0.5000 g Sample + tube: 1.5000 g

Empty tube: 1.0000 g

0.5000 g

Replace All...

Save Close Advanced

Sequence

Use to specify a default sequence for the sample file name. The number specified is sequenced incrementally each time a sample file is created. It is the number that appears in the **File name** field when using **File > Open > Sample information**.

- Use numbers, letters, or other printable characters, such as dashes. At least three numbers must be included.

Sample

Use to an additional identification.

In the field on the left, edit the prompt for **Sample**. For example, enter **Test** or **Material**.

In the field on the right, enter a default identification.

- Use the \$ symbol to have the automatically generated file number/name included in the identification. Enter the \$ symbol where the sequence number/name should appear.

For example, if the sequence number is 000-001, enter the identification as follows:

Lab #25 - \$

The resulting sample identification for the first sample information file would be:

Lab #25 - 000-001

for the second file:

Lab #25 - 000-002, and so on.

If additional information is added to the sequence number, the entire string will appear.

**Operator
Submitter
Bar code**

Use to enter defaults for the operator, submitter, and bar code information.

The fields on the left can be edited to display a different label for the prompts.

Operator Submitter Bar code (continued)	Use the fields on the right to specify default names or titles, and bar code information. <ul style="list-style-type: none">• Include the automatically generated file number/name as part of the identification by using the \$ symbol where the name is to appear• Select Omit adjacent to any field to omit the field from displaying on the sample information dialog.
Mass	Select to enter a sample mass or have the mass automatically calculated. The entry can be changed in the sample file.
Enter	Enables the Sample Mass field to enter a default value.
Calculate	Enables the Empty tube and Sample + tube fields. These values are used to calculate the mass of the sample, $Mass_{sample} = Mass_{sample+tube} - Mass_{tube}$
Replace All	Use to replace the contents of all parameter files contained in the current default sample file with those from an existing sample file. For example, if an existing sample file contains most (or all) of the parameters, click Replace All and select the file, and then click OK . All parameters of the file selected are copied into the sample defaults dialog.
Save	Saves the current values as the defaults.
Close	Closes the dialog.
Basic	Switches the sample editor to the Basic format.

Click each remaining tab of the Advanced Sample dialog to establish parameter defaults. See the following pages for additional assistance:

- [Analysis Conditions](#), page [5-12](#)
- [Report Options](#), page [5-25](#)

Basic

The defaults specified for the Basic format also serve as the defaults for the Restricted format.

The Basic Sample Defaults dialog displays in this manner.

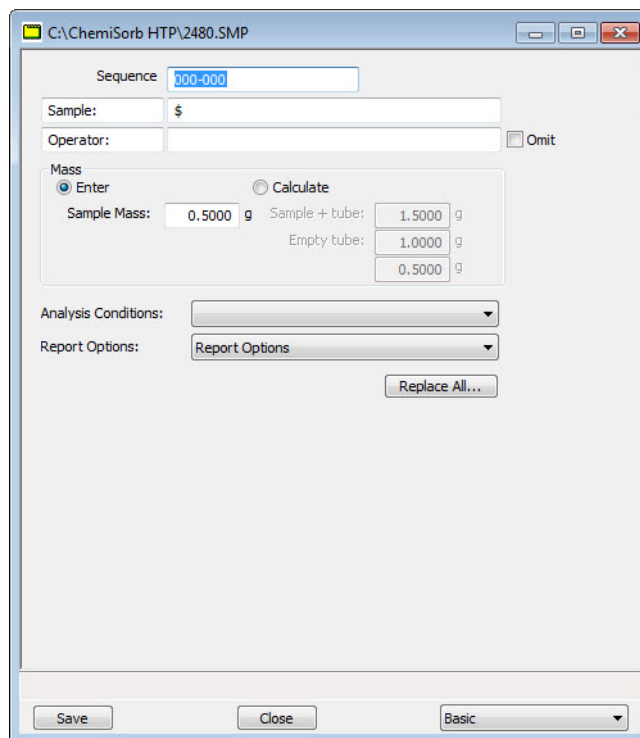

Sequence

Use to specify a default sequence for the sample file name. The number specified is incrementally sequenced each time a sample file is created. It is the number that appears in the **File name** field when using **File > Open > Sample information**.

Use numbers, letters, or other printable characters, such as dashes. At least three numbers must be included.

Sample

Use to enter an additional identification that provides more information than the sample file name itself.

Edit the **Sample** prompt - for example - enter **Test** or **Material**.

Sample
(continued)

Use to edit the default identification in the sample file to make it unique, or leave the default identification blank and enter the identification in the sample file when created.

Include the automatically generated file name as part of the identification by using the \$ symbol where the name should appear.

For example, if the name is 000-001, enter the identification as follows:

Lab #25 - \$

The resulting sample identification for the first sample information file would be:

Lab #25 - 000-001

for the second file:

Lab #25 - 000-002, and so on.

If an additional name was added to the sequence number, the entire string will appear.

Operator

Use to enter a default name for the operator.

Select **Omit** adjacent to the field to have the field omitted from the sample information dialog.

Mass

Use to enter a sample mass or have the mass automatically calculated. This information can also be changed in the sample file.

Enter

Enables the **Sample Mass** field to enter a default value.

Calculate

Enables the **Empty tube** and **Sample + tube** fields to enter default values. These values are used to calculate the mass of the sample,

$$Mass_{sample} = Mass_{sample + tube} - Mass_{tube}$$

**Analysis Conditions
Report Options**

Each parameter has a drop-down list containing predefined parameter files. Several default files are included with the analysis program. For files to appear in this drop-down list, they must be saved to the Parameter Files directory; the default directory is params. See [Parameter Files Directory](#), page 8-17.

Replace All

Use to replace the current default values with those from an existing sample file.

Save

Saves the current definition as the defaults.

Close

Closes the dialog.

Advanced

Switches the sample editor to the Advanced format.

Active Metals Defaults

Use to specify characteristics for up to twenty elements. Enter at least one element in the table.

	Element	Atomic Weight	Atomic Cross. Sect. Area (nm ²)	Density (g/cm ³)
1	chromium	51.996	0.0635	7.190
2	cobalt	58.933	0.0662	8.900
3	copper	63.540	0.0680	8.960
4	molybdenum	95.940	0.0730	10.220
5	nickel	58.710	0.0649	8.902
6	palladium	106.400	0.0787	12.020
7	platinum	195.090	0.0800	21.450
8	rhenium	186.200	0.0649	21.020
9	rhodium	102.905	0.0752	12.410
10	silver	107.868	0.0869	10.500

Element Displays the element. Elements may be inserted or deleted. See **Appendix D**, page **D-1** for a list of elements. This appendix provides a list of elements, their atomic weights, cross-sectional area, and density.

Atomic Weight The atomic weight of the element.

Atomic Cross. Sect. Area (nm²) The atomic cross-sectional area of the element.

Density The density of the element.

% of Sample Weight The percentage of element contained in the sample.

Adsorptive

Use to specify adsorptive properties for a selected element; displays the Adsorptives dialog for the selected element (in this example, chromium is shown).

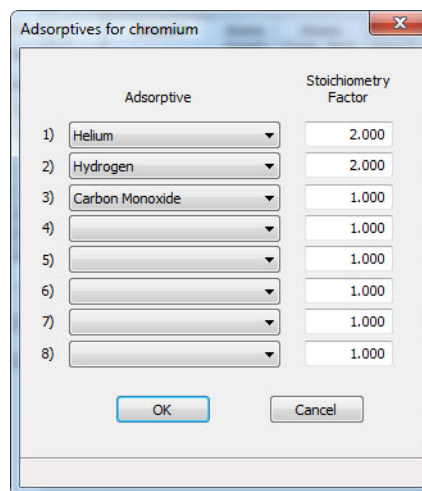
**Adsorptive**

Gases shown in the list are the ones specified in the Gas Table Defaults dialog. See [Gas Defaults / MFC Constants](#), page 8-14 for information on adding gases.

Stoichiometry Factor

A factor which expresses the ratio between the number of active metal molecules and the number of adsorbate molecules. This value is used in report calculations but not in the analysis itself.

Insert

Inserts a row above the selected row.

Delete

Deletes the selected row.

Clear

Clears the table of all entries except one; one is required.

Append

Adds a row at the end of the table.

Gas Defaults / MFC Constants

In order to characterize the gases used in an analysis, a symbol and a Mass Flow Controller (MFC) Constant must be defined. A table containing default gases and values is provided on the Options menu.

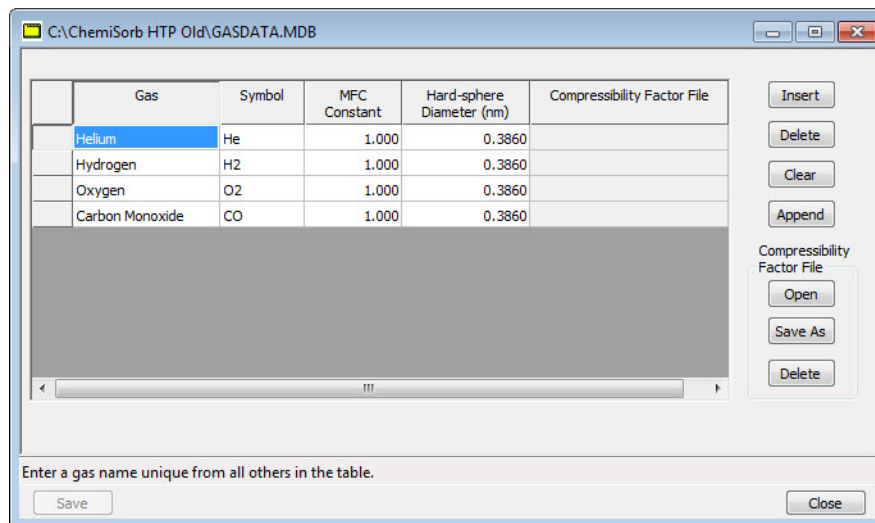

The gases contained in this table display in the drop-down lists for assignment to the gas ports (see [Unit Configuration](#), page 6-25).

Gas	Lists the name of the gas.
Symbol	Lists the standard symbol (mnemonic) for each gas.
MFC Constant	Contains the MFC Conversion Constant for each gas listed. This constant allows the MFC to control the gas flow precisely. If this number is incorrect, the actual flow rate for that gas differs from the rate reported. This value defaults to 1 when a new gas is listed. Enter the correct gas constant. A table of MFC conversion constants is provided in Appendix C , page C-1. If using a mixture of gases, determine an MFC Constant using the instructions in Appendix C .



In general, the MFC conversion constants provided with the analyzer are accurate and should be used.

Hard-sphere Diameter	Lists the hard-sphere diameter of the gas molecule.
-----------------------------	---

Compressibility File	Displays the path and name of the current compressibility file for the gas.
Insert	Inserts a row in which to enter a new gas and its values; the row is inserted before the selected row.
Delete	Deletes the selected row. No confirmation is provided. If a row is deleted in error, click Cancel to close the dialog and void the deletion; all other edits will be discarded as well.
Clear	Clears all but one entry of the table, after confirmation. One entry is required.
Append	Adds a row at the end of the table in which to enter a new gas and values.
Compressibility Factor File	Compressibility factors compensate for the forces of attraction between molecules in a real gas. Each gas compatible with the analyzer has a compressibility factor table.
Open	Use to load the compressibility table for the selected gas; the Open Compressibility Factor Table dialog is displayed. Highlight the file containing the mnemonic for the selected gas, then click Open .
Save As	Use to save the compressibility factor table as a different name. The Save Compressibility Factor Table dialog is displayed (identical to the above), to enter a file name.
Delete	Removes the compressibility data from the selected gas.

Units

Use to display the Units Selections dialog. Select the manner to display data on dialogs and in reports.

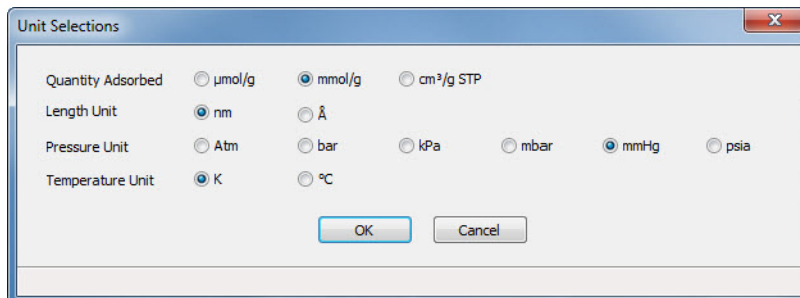

Graph Grid Lines

Use **Graph Grid Lines** to select the type of grid lines to display on reports; the Graph Grid Lines dialog is displayed.

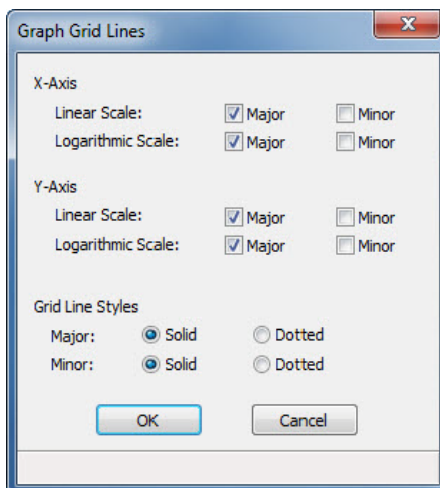

X-Axis
Y-Axis

Use to select **Major** and/or **Minor** lines to display in printed reports for the Logarithmic and Linear scales.

If not selected, the report will not display grid lines.

Grid Line Style

Use to select the type of grid line to display if grid lines are being shown.

Thermal Transpiration on Live Graph

Select to apply thermal transpiration to pressure in the live graph (see page 5-28 for additional information on thermal transpiration).

Parameter Files Directory

Use to specify a location for the predefined Analysis conditions and Report options files displayed in the drop-down lists on the Basic and Restricted Sample Information dialogs.

When selected, the Parameter File Directory Selection dialog is displayed.

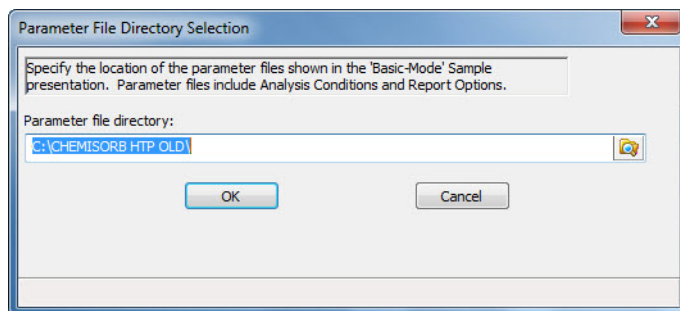

The directory specified is the one to be used when creating parameter files to be included in the drop-down lists on the Basic and Restricted sample information dialogs. It is where the application looks to retrieve files for the drop-down lists. The default directory is **PARAM** and includes several parameter files supplied with the analysis program. If a different directory is specified, these files will not be included in the drop-down lists unless they are copied or moved to the new directory.

To continue to use the **PARAM** directory for parameter files, it will display as the default when saving parameter files.

Service Test Mode

Various service tests are included in the ChemiSorb application. These tests can be performed only with the assistance of a trained Micromeritics service representative. When using **Options > Service Test Mode**, a dialog prompting for a password is displayed. This password is coded to change on a regular basis. Contact your local service representative to obtain the correct password. Tests cannot be performed without his guidance.

9. TROUBLESHOOTING AND MAINTENANCE

The ChemiSorb system has been designed to provide efficient and continuous service. However, certain maintenance procedures should be followed to obtain the best results over the longest period of time.

For information on vacuum pump maintenance, log on to your customer portal to access the Vacuum Pump Guide (part number 062-42804-00).

Troubleshooting

What Happened	Why	What To Do
Vacuum pump is noisy	Sample tube fitting or connector nuts are loose.	Turn the connector nuts clockwise to tighten. 
	Sample tube is cracked.	Replace with a new sample tube.
	A gas inlet valve is open while the vacuum valve is open.	Enable manual control, then use the instrument schematic to close the gas inlet valve. see Enable Manual Control , page 6-13.
Furnace cannot be raised (or lowered).	Possible obstruction.	Check for and correct any obstruction that may be in the path of the elevator.
Valves cannot be operated.	Ethernet cable from the computer to the instrument is loose.	Ensure the ethernet cable is seated securely.
High-vacuum pump indicator light is not on	No power to the pump.	Restore power to the pump.
	Pump slowed down evacuating a large gas volume. It should turn on the indicator light after accelerating again.	Wait 5 minutes for the pump to speed up. If power is not restored, see the causes for Vacuum pump is noisy above.

Preventive Maintenance

The table below lists the preventive maintenance procedures that should be completed to keep the analyzer operating at peak performance. Instructions for each procedure follow the table. Micromeritics also recommends that preventive maintenance procedures and calibration be performed by one of our service representatives every 12 months.

Maintenance Required	Frequency
Clean the outside of the analyzer, page 9-4	As required or every 6 months
Replace sample tube O-ring, page 9-4	As required or every 6 months
Replace port filters and O-rings, page 9-6	As required or every 6 months
Lubricate elevator drive assembly, page 9-3	Every 12 months
Perform a reference material analysis	As required or every 3 months

Lubricating Elevator Drive Assembly

The elevator screws should be greased annually to maintain smooth movement of the elevator.

1. Remove the middle panel on the back of the analyzer by loosening, then removing the retaining screws.
2. Apply a light coat of lithium grease at the base of all six elevator screws.

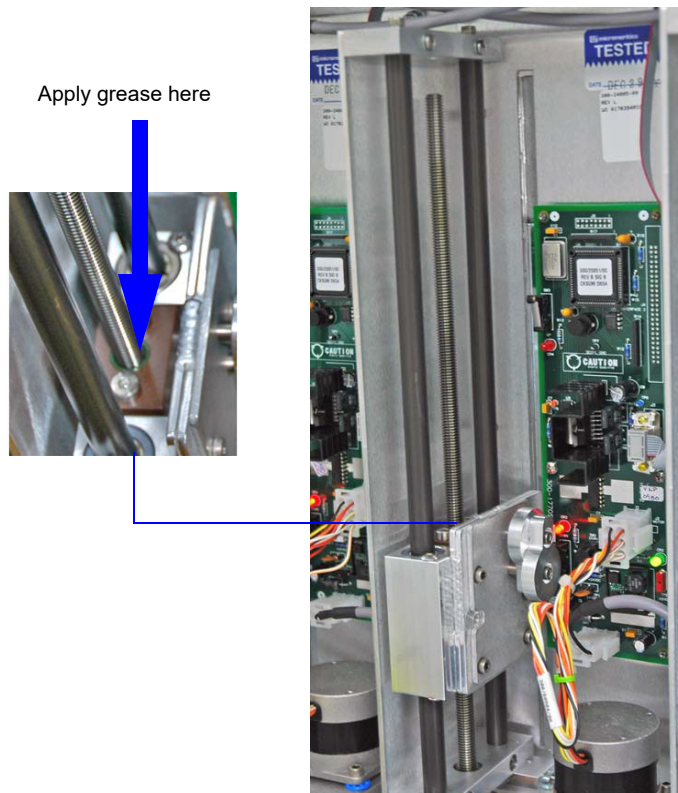

3. Using the **Up** and **Down** buttons on the front panel of the analyzer, raise and lower each of the elevators 2 or 3 times to distribute the grease evenly.

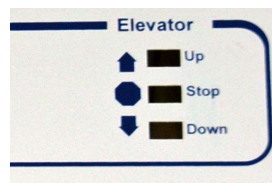

4. Wipe away any excess grease at the base of the elevator screws.
5. Replace the back panel.

Cleaning the Analyzer

The exterior casing of the analyzer may be cleaned using a clean cloth, dampened with isopropyl alcohol (IPA), a mild detergent, or a 3% hydrogen peroxide solution. Do not use any type of abrasive cleaner.



Do not allow liquid to penetrate the casing of the analyzer. Doing so could result in damage to the unit.

Clean the shield only with mild soap and water. Do not use glass cleaner, ammonia, IPA, or acetone.

Replacing the Sample Tube O-rings

It is important to maintain a vacuum-tight seal near the top of both sample tube stems (analysis and exhaust). If an O-ring becomes worn or cracked, it does not provide a good seal and will need to be replaced.



Before removing (or installing) a sample tube, ensure that the port valve is closed. Observe the instrument schematic to verify valve status and sample backfill.

1. Make sure the analysis port (sample valve) is closed and the furnace is in its lowest position.
2. Place something on top of the furnace area to prevent anything from falling into the furnace.
3. Holding the sample tube firmly with one hand, loosen the connector nuts for the sample tube and the exhaust tube by turning counterclockwise.
4. Finish unscrewing the connector nuts, being careful not to let them drop onto the bottom of the tube.



Be careful not to let the sample tube connector nuts drop onto the bottom of the tube as it may break the tube.

- Carefully pull the sample tube down until it is free from the port.

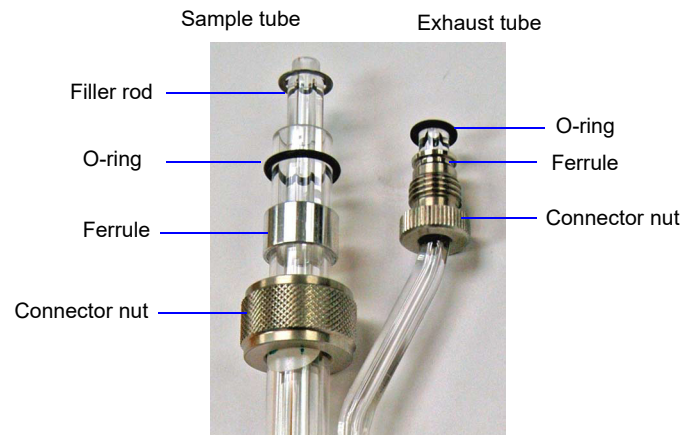

- Remove the filler rod from the sample tube. Then remove the O-rings from the sample and exhaust tubes and replace with new ones.
- Replace the filler rod, then insert the sample tube back into the sample and exhaust ports until it is fully seated.
- Slide the connector nuts up the tubes (the ferrule and O-ring will move along with the connector nut). Then, turning clockwise, **hand-tighten** the connector nuts for the sample and exhaust tubes.

Replacing the Port Filters and O-rings

Using a contaminated filter on the analysis port may extend the time required to achieve a vacuum at that port. More importantly, the contaminant may adsorb or desorb during analysis, affecting analysis results. A contaminated filter on the analysis port may be detected by a leak test (if the contaminant outgasses) or by a free space reading much lower than normal.

A 20- μ m filter is located in each analysis (1/4 in.) and exhaust (3/16 in.) port of the analyzer.

Perform the following steps to replace the filters:

1. Make sure the analysis port (sample valve) is closed and the sample tubes are backfilled with a safe gas.
2. Lower the furnace and remove the sample tube.
3. Place something on top of the furnace area to prevent anything from falling into the furnace.
4. Loosen the three captive retaining screws underneath the grill, then pull down to remove the grill from the top panel.

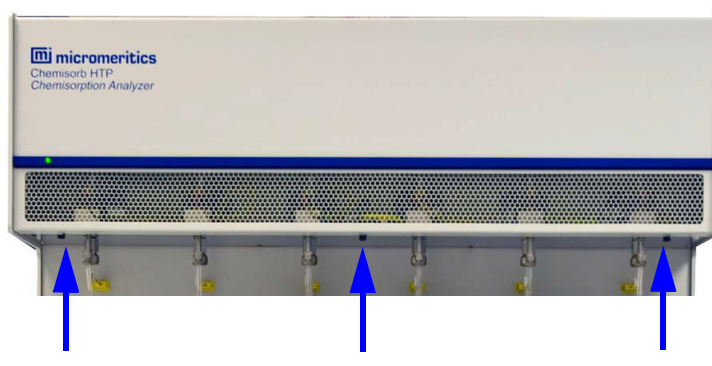

5. Using a wrench, loosen the sample and exhaust tube fittings.
6. Unscrew and remove the exhaust tube fitting from its connector. Lay it aside until the sample tube fitting has been removed.
7. Slide the exhaust valve from its retaining bracket; move it out of the way of the sample tube fitting. Do not disconnect any wiring or tubing.

- Slide the foam insulator down from the top of the fitting, unscrew the sample tube fitting, and remove the fitting from its connector. Screw the red cap (provided in the accessories kit) on the end of the fitting to prevent contamination from the insulator; be sure the cap is clean.



- Pull the port fitting down and remove the foam insulator. Then unscrew the cap and completely remove the port fitting from the analyzer.
- Remove the O-rings and filter frits from the sample and exhaust port fittings and replace with new ones (extra O-rings and filter frits are provided in the accessories kit).

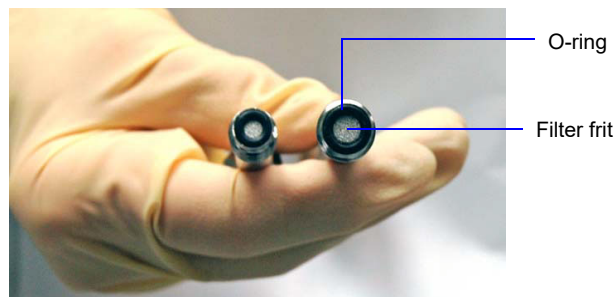

Occasionally, the O-ring and/or filter will remain in the port. Use a pointed plastic tool to gently dislodge from the port. Be careful not to scratch or contaminate the manifold.

- Clean both port fittings with acetone or alcohol.

12. Reinstall the Sample port fitting first.
 - a. Insert the clean fitting through the opening and screw on the red cap (to maintain cleanliness of the O-ring and filter).
 - b. Slide the foam insulator onto the port fitting.
 - c. Pull the foam insulator down and remove the red cap.
 - d. Insert the port fitting into its connector, then release the insulator. Do not allow the insulator to touch the top of the fitting.
 - e. Screw the port fitting onto its connector until it is fully seated, then tighten with the wrench to prevent leaks when evacuated.
13. Slide the exhaust valve back into its retaining bracket and reinstall the exhaust port fitting.
14. Reinstall the grill on the front panel; hand-tighten the retaining screws.

Connecting Gases

This section includes instructions for attaching gas bottles to the instrument.

Guidelines for Connecting Gases to the Analyzer

Use these guidelines when installing regulators and gas lines:

- Place gas bottles close to the analyzer. Using gas line extenders on gas bottles located in remote areas may degrade gas quality and reduce pressure.
- Use a retaining strap (or other appropriate tether) to secure the gas bottle.
- Carefully route the gas lines from the bottle to the analyzer, avoiding overlapping or entangling gas lines.
- Label the gas line at the instrument inlet for proper identification and maintenance.
- Ensure that the gas bottle is closed before connecting to the analyzer.
- Use 70 psi to 120 psi dry air or other dry inert gas.



If using house air, it must be dried before entering the instrument.

The instructions below describe a typical installation. Some configurations require additional components, such as regulator expansion kits, when one gas source will be used for several operations or when the gas bottle cannot be located close to the analyzer.

Disconnecting the Depleted Bottle

1. Close the gas bottle shut-off valve, then open the regulator shut-off valve.

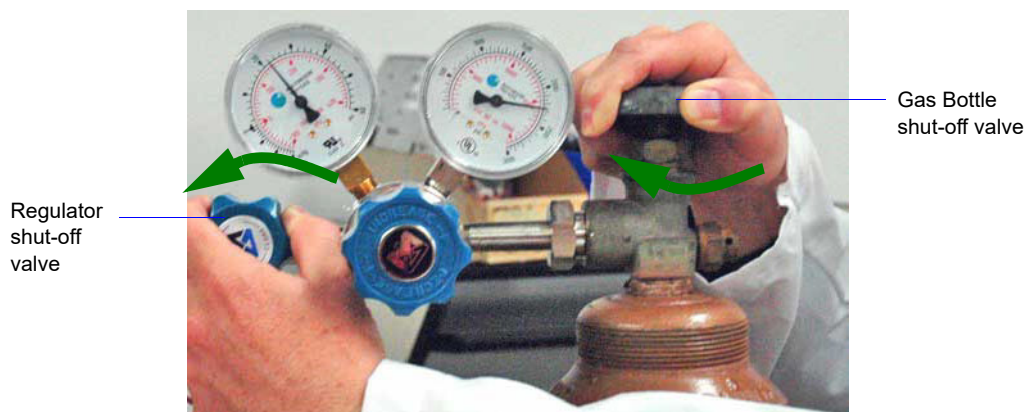

2. Both gauges should read at or near zero; if not, disconnect the gas line from the regulator and allow the pressure to purge from the lines.

3. Use an appropriate wrench to loosen the nut at the regulator/gas bottle connection, then remove the regulator from the bottle.



The gas line does not have to be disconnected from the regulator or the instrument.

4. Replace the protective cap on the depleted bottle, disconnect the retaining strap, and remove the bottle from its current location.

Connecting a Replacement Gas Bottle

Move the replacement bottle close to the instrument and tether it into place.



When connecting hazardous gases, be sure to vent properly and follow the safety procedures established for your lab.

1. Use an appropriate cylinder wrench to remove the protective cap from the replacement bottle.



2. Attach the gas regulator to the connector on the gas bottle. Hand-tighten the nut, then use an appropriate wrench to tighten an additional 3/4 turn.



Do not overtighten the fitting; doing so may cause a leak.

3. Check for leaks at the high-pressure side of the regulator and in the connector.

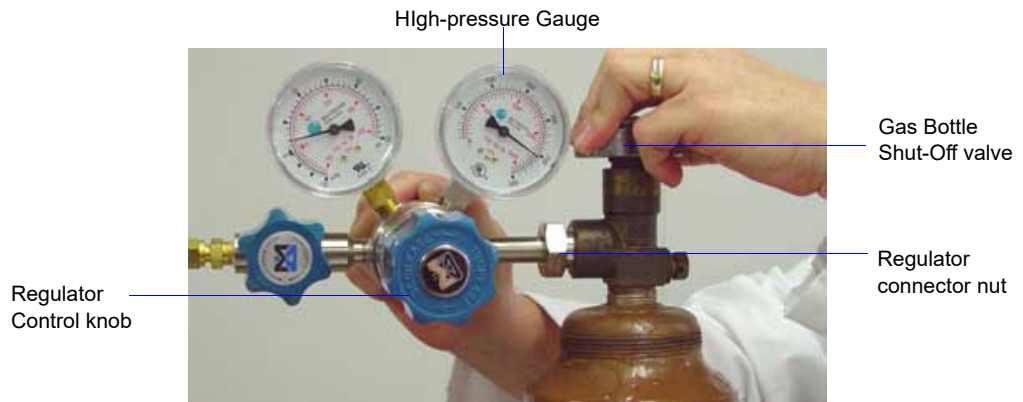

- a. Turn the regulator control knob fully counterclockwise.
- b. Slowly open the gas bottle shut-off valve, then close it.
- c. Observe the pressure on the high-pressure gauge.
 - If the pressure is stable, proceed with the next step.
 - If the pressure decreases, tighten the regulator connector nut until it becomes stable.

4. Purge the air from the lines.



- a. Turn the regulator shut-off valve counterclockwise to open.
 - b. Open the gas bottle shut-off valve to flow gas.
 - c. Close the regulator shut-off valve to stop flow.
 - d. Close the gas bottle valve.
5. Set the instrument pressure.



- a. Turn the regulator control knob clockwise until the low-pressure gauge reads 22 psig (152 kPag).
 - b. Open the regulator shut-off valve.
 - c. Open the gas bottle shut-off valve and flow gas for 10 to 30 seconds.
 - d. Close the gas bottle shut-off valve.
6. If the gas line to the instrument inlet was disconnected, reconnect it now.
7. If the same gas was connected as the one removed, no additional configuration change is required. If a different gas was connected than the one removed, specify the change; see [Specifying Gas Ports](#), page 9-13.

Specifying Gas Ports

The ChemiSorb has gas inlets for up to 12 analysis gases. The gases connect to the inlets must be specified in the analysis program. If a gas is changed on one of the inlets, the gas assignment must also be edited. It is very important that the analysis program be kept informed of any change in gases.

1. Select **Unit [n] > Unit Configuration**; the Unit Configuration dialog is displayed.

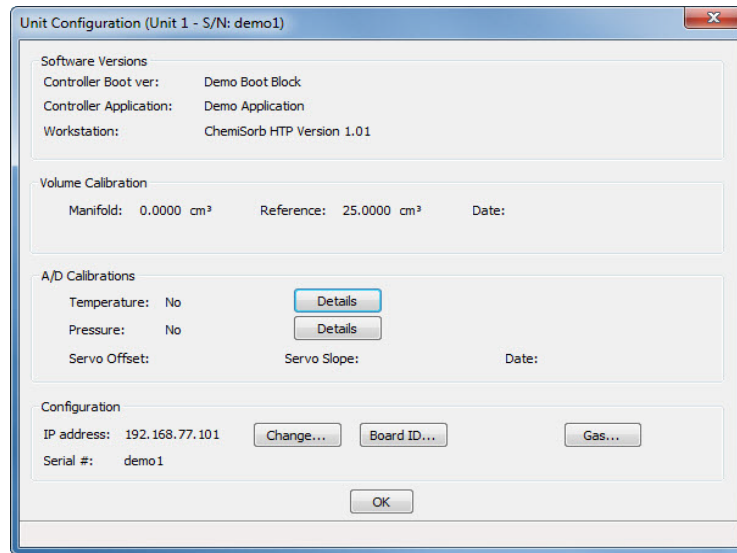

2. Click the **Gas** button in the Configuration group box; the Gas Configuration dialog is displayed.

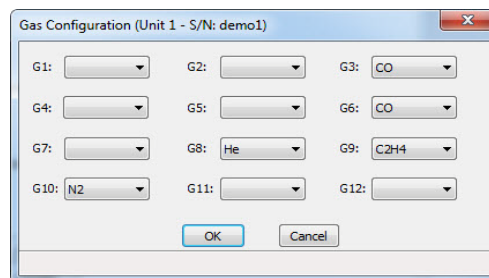

3. Click the down arrow at the appropriate port and select the gas attached to the port from the list.
4. Click **OK** to save the selections and close the Unit Configuration dialog.

10. ORDERING INFORMATION

Use one of the following methods to order components and accessories for the ChemiSorb HTP system:

- Call our Customer Service Department at (770) 662-3636
- Email orders to orders@micromeritics.com
- Contact your local sales representative

Please use the following information to place an order.

Part Number	Item and Description
Cables	
003-63801-00	Ethernet cable
Gas Bottle Accessories	
004-25318-00	Reducer, stainless steel; 1/8 in. tube × 1/4 in. tube, accepts 1/8 in. tube, connects to 1/4 in. swage fittings
004-25549-00	Reducer, brass; 1/8 in. tube × 1/4 in. tube, accepts 1/8 in. tube, connects to 1/4 in. swage fittings
004-33601-00	Expansion Kit; adds an additional outlet to the gas regulator, includes fittings and instructions
004-33602-00	Pressure Relief Kit; prevents excessive gas pressure in the event of regulator failure (not to be used with noxious gases)
004-62230-32	Gas pressure regulator, CGA 320 fitting (CO ₂), 30 psig
004-62230-35	Gas pressure regulator, CGA 350 fitting (CO, H ₂), 30 psig
004-62230-54	Gas pressure regulator, CGA 540 fitting (O ₂), 30 psig
004-62230-58	Gas pressure regulator, CGA 580 fitting (Ar, He, Kr, N ₂), 30 psig
201-25818-00	Gas inlet line assembly, stainless steel, 1/8 in. diameter, 6 ft. long
201-25818-01	Gas inlet line assembly, stainless steel, 1/8 in. diameter, 16 ft. long

Part Number	Item and Description (<i>continued</i>)
290-25846-00	Copper tube, for gas inlet, 1/8 in. diameter × 6 ft. length
290-25846-01	Copper tube, for gas inlet, 1/8 in. diameter × 16 ft. length
Miscellaneous	
004-32187-00	Gloves, cotton insulated
248-31702-00	Insulator disk, for oven, top
248-31706-00	Insulator disk, for oven, bottom
248-32701-00	Shield, for furnace
Operating Supplies	
003-22633-02	Valve plunger for x-valve
003-53048-07	Thermocouple
004-25011-01	O-ring, -011 KALREZ, for x-valve manifold
004-25105-00	Front ferrule for exhaust line
004-25106-00	Rear ferrule for exhaust line
004-25158-00	Tool, for x- valves, 3-way
004-25474-00	O-ring, -013 KALREZ, for x-valve manifold
004-28410-01	Clip, for thermocouple
004-32025-00	Tubing, Tygon F-4040-A, 5/16 in. ID for instrument exhaust
004-32173-01	Tubing, Tygon F-4040-A.12 × .25 exhaust tubing from exhaust manifold to outside of instrument
004-62002-03	Plunger with spring 3-way valve
201-22600-00	Valve spring for mangalatch valve
248-25860-00	Tube, 3/8 D × 2.34 For exhaust

Part Number	Item and Description (<i>continued</i>)
248-32703-00	Mat, black, rubber, for lower shelf
250-25608-00	Valve gasket, Kel-F, for analysis manifold
250-25627-00	Valve plunger, Buna-N seal, for analysis manifold
Pneumatic Supplies	
004-25681-01	Hose fitting for compressed air for furnace cooling
350-77600-00	Pneumatic Filter Assembly for air source
Reference Materials	
004-16825-00	Reference material, chemisorption
Sample Tube Accessories	
004-25409-01	Cap for changing sample port frits
004-25653-00	Sample tube brush
004-32164-01	Wool, quartz, use with quartz sample tubes to constrain sample
004-54609-01	Sample tube brush for exhaust stem
004-54618-00	Tool, for removing sample port o-ring
004-54805-00	Tool, for extracting quartz wool from the sample tube
240-14855-00	Sample tube rack
240-25853-00	Sample tube funnel
248-32702-00	Quartz filter disc for sample tubes (100 per package)
280-32800-00	Sample tube support, assists sample weighing

Part Number	Item and Description (<i>continued</i>)
Sample Tube Components	
248-61001-00	A - Sample tube, quartz
248-61004-00	B - Hanging filler rod, quartz
004-25466-00	C - O-ring, size -010, Buna-N; for sample tube exhaust
004-27041-00	D - Port filter, 20 μm , 1/4 in. diameter
004-25044-00	E - O-ring, size -013, Buna-N, for sample tube
260-25843-00	F - Ferrule, 1/2 in.
300-25824-00	G - Sample port connector nut
240-32000-00	H - Stopper, for 1/2 in. sample tube
004-25673-00	I - O-ring, size -008, Kalrez

Part Number	Item and Description (<i>continued</i>)
004-27056-00	J - Exhaust filter, 20 µm, 3/16 in. diameter
275-25803-00	K - Ferrule, 1/4 in. stainless steel
201-25822-00	L - Exhaust nut
004-32604-08	M - Cap (stopper), for 1/4 in. sample tube
Software and Manuals	
248-20800-00	ChemiSorb HTP - current version software
248-33001-00	ChemiSorb HTP - Operator Manual and current software
248-42800-00	ChemiSorb HTP - Operator Manual
Vacuum Pump and Accessories	
004-16003-01	Oil, vacuum pump, 1 liter
004-16830-00	Alumina
004-25630-00	Centering ring NW 16, for alumina trap
004-25653-00	Ring, centering, NW 16/10, for alumina trap
004-28998-02	Hose clamp, for vacuum pump
004-32025-00	Tubing, Tygon 5/16 ID, for vacuum pump exhaust
200-25879-00	Assembly, funnel
202-25814-00	Fitting, Adapter KF16, for vacuum pump exhaust

A. ERROR MESSAGES

Error messages are listed numerically. If the **Action** response instructs you to contact your service representative, record the error message and make backup copies of any files involved in the operation.

2200 and 2400 Series

2201- Cannot execute report subsystem.

Cause: Start Report failed to execute the report subsystem (which is a separate process).

Action: Restart the computer. If the problem persists, reinstall the application (this will not affect sample files). If the problem continues, contact a Micromeritics service representative.

2401- FATAL ERROR: (error message)

Cause: An internal processing and/or hardware error has occurred.

Action: Contact your service representative if this message continues.

2430- Error accessing file (file name), error code = (number).

Cause A: Media may be damaged.

Action A: Clean the media drive. If this does not eliminate the problem, attempt operation using a backup copy of the file.

Cause B: Hard disk may be damaged.

Action B: Contact your service representative.

Cause C: A software error occurred when the file was accessed.

Action C: Contact your service representative.

2431- Error writing file (file name), error code = (number).

Cause: The hard disk does not have enough space left to perform the operation.

Action: Copy files not used regularly from the hard disk to a portable media drive or network directory, delete them from the hard disk, and then try the operation again.

2432- Invalid response from MMI 'FILE_READ' request.

Cause: An internal processing and/or hardware error has occurred.

Action: Contact your service representative if this message continues.

2433- New entries have been found in this directory. Refresh the directory information?

Cause: Program files (sample information, analysis conditions, or report options) have been added to this directory by some function other than this application.

Action: Click **Yes** to update the directory information with data from each new file. This operation may take a minute.

Click **No** to not update the directory information. This option may be feasible if a large number of files have been copied into the directory and file name is known.

2434- File (file name) — Subset # (number) wrote [nn] bytes, expected [nn] bytes.

Cause: An internal processing and/or hardware error has occurred.

Action: Contact your service representative if this message continues.

2436- Path specification (path name) is invalid.

Cause: An invalid path name and/or extension was entered.

Action: Type a valid path name (including the proper extension) and press **Enter**.

2437- File (file name) does not exist.

Cause: A file specification was entered that does not exist.

Action: Enter an existing file specification or select a file name from the Files list.

2438- Disk drive (letter): is inaccessible.

Cause: A disk drive was selected that is not presently accessible.

Action: Ensure that the disk is not write-protected.

2439- Cannot register file.**2440- Subset not found.****2441- Seek within file failed.****2442- Bad header in subset file.****2443- Subset owner denied access.****2444- Not a valid file format.****2445- Subset wrote the wrong amount of data.****2446- Error reading data.****2447- Error writing data.**

Cause: An unexpected error occurred trying to access a data file.

Action: Contact your service representative.

2448- File directory (path name) is invalid. Resetting to the installation directory.

Cause: A working directory specified in the .INI file is invalid. The directory may have been deleted or moved to a different location.

Action: The installation directory will be substituted. Use the search icon to navigate to the correct directory.

2449- This field does not contain a valid file specification.

Cause: An invalid file name was entered.

Action: See the description of file naming conventions in a DOS or Windows manual and re-enter the name.

2450- Sample Defaults may not be edited while this operation is in progress. Do you wish to save and close the Sample Defaults edit session?

Cause: You are in the process of initiating an automatic analysis (an analysis in which sample files are created using the defaults) while editing the defaults.

Action: Finish the edit session of the defaults and close the dialog. Then restart the automatic analysis.

2452- Attempt to write MICATTR.DIR in read only mode. (file name)**2453- Attempt to append MICATTR.DIR in read only mode. (file name)**

Cause: The Read-Only attribute is turned on in the application's MICATTR.DIR file (this file exists in each folder containing sample or parameter files).

Action: Use Windows Explorer to access the folder containing the MICATTR.DIR file and disable the Read-Only option.

2454- Too many selections for a print-to-file operation. Only the first (number) selections will be processed. Please reselect the remainder.

2455- Too many selections for an export-to-file operation. Only the first (number) selections will be processed. Please reselect the remainder.

Cause: Too many files were selected for this operation.

Action: Select only the number of files specified in the message.

2456- Insufficient file handles available. Application cannot continue.

Cause: More than 50 files were open at the same time.

Action: Refer to the manual for your operating system and set the limit for open files to 50 or greater.

2457- Results cannot be displayed. More than (number) windows are currently displaying or printing results.

Cause: Too many windows are open in the application.

Action: Close some of the open windows.

2458- An instrument is performing a critical operation. Wait a few moments before exiting the application.

Cause: An attempt was made to exit the application while the analyzer was performing a critical operation. This operation must be completed before the application can be stopped.

Action: Wait a few minutes before attempting to exit the application again.

2459- An instrument is busy. A delay in restarting this application could result in loss of new data. Continue with program Exit?

Cause: An attempt was made to exit the application while an analysis is in progress. While this is possible, the data collected while the application is inactive will not be permanently recorded until the application is restarted. A power failure to the instrument could cause some data to be lost.

Action: If not concerned with the potential for loss of data should a power failure occur, click **Yes** to continue; otherwise click **No**.

2460- Fatal Communications error on (unit n).

Cause: There was a fatal error in communication between the application and the software in the instrument. All displays for that instrument will be closed.

Action: Ensure that the analyzer is connected to the computer on the ethernet port configured in the Setup program. Exit the application and then restart it. Contact your service representative if this message continues.

2461- No instruments are in operation. This application will unconditionally terminate.

Cause: At least one analyzer must be active for the application to operate. The initialization of the analyzers configured with the Setup program has failed. The application stops.

Action A: Usually this message is preceded by another message giving the reason for the analyzer's failure to initialize. See the instructions for that message.

Action B: Check the cable connection between the analyzer and the computer. Verify that the analyzer has the power switch in the **ON** position and that the light on the front panel is illuminated. If the application continues to fail in its attempts to initialize the analyzer, contact your service representative.

2477- (Unit n; Serial nn) did not properly initialize.

- Cause:* The software was unable to initialize the analyzer.
- Action A:* Run the Setup program and ensure that a valid ethernet port is selected; if not, select a valid one when prompted.
- Action B:* Reinstall the software, then restart application.
- Action C:* Contact your service representative if this message continues.

2478- Error copying sequential data segment.

- Cause:* An internal processing and/or hardware error occurred while accessing a portion of a sample file.
- Action:* Confirm that the media being accessed does not contain errors; for example, use a utility such as ScanDisk. Contact your service representative if this message continues.

2479- (Unit n; Serial nn) The instrument is busy performing an operation of which this application is unaware. Do you want to cancel? (Yes, No)

- Cause:* During initialization of the application, the status of the analyzer was found to be in a different state than expected.
- Action:* Click **Yes** to cancel the operation in process, allowing the analyzer to reset and continue with initialization.
- Click **No** to cancel the initialization process.
- If this message continues, verify that files in the application directory structure are not being changed or removed.

2480- File (file name) cannot be analyzed. It is currently being edited.

- Cause:* An analysis was attempted using a sample file that is being edited.
- Action:* Save the changes and close the dialog.

2481- Error accessing the sample information file (file name).

Cause A: An attempt was made to open a file that is already open, possibly minimized.

Action A: View the minimized icons, locate and maximize the file.

Cause B: A computer or network problem occurred.

Action B: Check the performance of the computer devices or network.

Cause C: A software error occurred when the file was accessed.

Action C: Contact your service representative.

2482- File cannot be opened for writing. It is already in use.

Cause: An attempt was made to open a file that is currently being used, possibly minimized.

Action: View the minimized icons, locate and maximize the file.

2483- An analysis cannot be performed on (file name). It is open for editing and contains errors.

Cause: An attempt was made to use a sample file containing errors that is currently open.

Action: Go to the window containing the file, correct the errors, and save it.

2484- The edit session for (file name) must be saved before the analysis. Save changes and continue with the analysis.

Cause: An attempt was made to start an analysis using a file that contains unsaved changes and is open for editing.

Action: Select **Yes** to save the changes and continue the analysis.

Select **No** to cancel the analysis and return to the sample file.

2486- Cannot construct (name) report type. Program will terminate.

2487- Cannot start report generator. Error code (number). Program will terminate.

Cause A: Full rights to the application's folders and files are required.

Action A: Contact your system administrator and have him grant you full rights.

Cause B: An internal processing and/or hardware error has occurred.

Action B: Contact your service representative if this message continues.

2488- File (file name) cannot be opened for editing.

Cause: The file specified is being used in another edit operation.

Action: Check the Windows list to locate the other edit session.

2489- File (file name) cannot be opened for writing.

Cause: The file specified in a **Save As** operation is already open for edit.

Action: Select a different file for the **Save As** operation.

2490- No '.INI' file present. Application will terminate.

Cause: The ASCII (.INI) file containing initialization and system options information cannot be found. The .INI file may have become corrupted. The application cannot operate without this file.

Action: Use the Setup CD to uninstall the application, then reinstall it to create a new INI file.

When the application is un-installed, only the application files are deleted; data files remain intact.

2491- Highlighted fields contain errors. Please correct the errors before closing.

Cause: The highlighted fields contain invalid entries. The dialog cannot be closed until all errors are corrected.

Action: Check the entries, correct the errors, and close the dialog.

2492- This field's entry is invalid.

Cause: The highlighted field contains an invalid entry.

Action: Check the entry and correct the error.

2493- An entry is required for this field.

Cause: This field requires a valid entry to proceed.

Action: Enter or select an appropriate value.

2494- Value is out of the valid range.**2495- Value is out of the valid range. Enter a value between (value) and (value).**

Cause: The value entered in the highlighted field is outside the valid range of values.

Action: Check the entry and enter or select an appropriate value.

2496- Invalid number.

Cause: The number entered in the highlighted field is invalid.

Action: Check the entry and enter or select a valid number.

2497- This field contains an invalid character.

Cause: An invalid character was entered in the highlighted field.

Action: Check the entry and enter valid characters.

2498- The requested change to the Sample's status is invalid at this time.

Cause: A request to change the file's status (for example, from automatically collected to manually entered) could not be done.

Action: Contact your service representative if this message continues. Record the name of the sample file in which the problem occurred.

2499- Sequence number must contain at least 3 digits.

Cause: An attempt was made to enter a sequence number that did not contain at least three digits.

Action: Enter a sequence number that contains at least three digits.

2500 Series

2500- All sample file names that can be created using the sequence number pattern already exist. You may want to modify the next sequence number.

Cause: No more sample information files can be created using the currently entered file name sequence number.

Action: Select **Options > Sample Defaults** from the Main Menu and enter a new sequence number.

2501- System resources have reached a dangerously low level. Please close some windows to avoid the loss of data.

Cause: A large number of windows are open and consuming the system resources available to all applications.

Action: Close one or more windows on the screen. Contact your service representative if this message continues.

2502- Error writing to file (name) during print. Error code: (number).

Cause: An error occurred in the file being written to during a print operation.

Action: Ensure that there is sufficient space on the drive containing the file.

2503- Error converting file (file name). Could not create DIO intermediate file.

Cause A: Insufficient space is available on the hard disk. The DIO file is placed in the directory specified by the TEMP environment variable.

Action A: Determine if there is sufficient space on the drive where the TEMP directory is located.

Cause B: An internal processing and/or hardware error has occurred.

Action B: Contact your service representative if this message continues.

2504- Cannot create output file for sample (sample name).

Cause: Insufficient space may be available on the hard disk.

Action: Ensure that sufficient space is available. Contact your service representative if this message continues.

2505- Error Logger cannot be initialized. Error code (number). Program will exit.

Cause: An internal processing and/or hardware error has occurred.

Action: Contact your service representative.

2506- (sample file) Output device (name) is not installed. Printing cannot be accomplished.

Cause: The selected output device is not installed in Windows.

Action: Install the device using the Control Panel, Printers operation, or select a different output device.

2508- (sample file) Overlay file (name) was not found. It will not be included in the reports.

Cause: The specified overlay file could not be found.

Action: Ensure that the file specified as an overlay does exist.

2509- (sample file) Error opening file (name): (error). Reports cannot be produced.

Cause: An error occurred while the program was opening a file necessary to the report operation.

Action: Use the name given in the error message to investigate. Contact your service representative if this message continues.

2510- (sample file) Error parsing reports from file (name). Reports cannot be produced.

Cause A: One or more data entry fields in the sample file may contain an invalid character (such as a single quote or double quotes).

Action A: Review the data entry fields (for example, the Sample field) and remove the invalid character.

Cause B: The system was unable to create the usual temporary files during the report, possibly due to insufficient disk space.

Action B: Check the space available on the hard disk.

Cause C: An internal processing error occurred.

Action C: Contact your service representative.

2511- Print job (name) has been cancelled due to insufficient disk space. Delete unnecessary files and restart the report.

Cause: The disk drive does not have enough space for the temporary file required by the Windows Print Manager. Therefore, printing of the requested report has been canceled.

Action: Delete unnecessary files from the disk.

2512- Print job (name) been canceled.

Cause: The requested print job was canceled at the user's request.

Action: None required.

2513- Unable to read the calibration file (file name).

Cause: An invalid calibration file or one that cannot be read was selected.

Action: Ensure the media containing the calibration file has no problems.

2514- Unable to write the calibration file (file name).

Cause: An attempt to save calibration data has failed due to possible media problems.

Action A: Be sure the media to save the file to has no problems.

Action B: Select an alternate media to save the calibration data.

2515- Warning: Changing the calibration information will affect the performance of the instrument. Only qualified service personnel should do this. Do you wish to proceed?

Cause: The process of performing a calibration operation has started.

Action: Calibration operations should only be done by or under the direction of qualified service personnel.

2516- Warning: Keeping a backup copy of the calibration data is recommended by Micromeritics. Would you like to do so now?

Cause: A calibration operation has been performed; a backup copy is recommended.

Action: Perform a calibration **Save** operation.

2517- Canceling this dialog will reset the calibration state to what it was when this dialog was first opened. Are you sure you want to cancel?

Cause: The calibration performed has not been accepted.

Action: If the calibration operation was successful, click **Accept**.

2520- No data points available for reporting.

Cause: A request was made for a report for a data file which contained no data points relevant to the report.

Action: The affected report will not be produced. If the data file contains no points, select another file for the report. If the data file contains points, verify that a sufficient number of points was selected for the report on the Collected/Entered Data dialog.

2521- Unable to program controller.

Cause: A hardware malfunction has occurred.

Action: Contact your local Micromeritics service representative.

2522- Invalid controller application file.

Cause: The application's control file is corrupt or has been deleted.

Action: Reinstall the ChemiSorb analysis program.

- 2523- Programming the controller failed.
- 2524- CRC check failed on programming controller.
- 2525- Unknown error programming controller.
- 2526- Controller download was not successful.
- 2527- Controller CRC error on boot block.
- 2528- Controller DRAM error.
- 2529- Controller Com1: error.
- 2530- Controller Com2: error.
- 2531- Controller debug port error.

Cause: An internal processing and/or hardware error has occurred.

Action: Contact your service representative if this message continues.

2532- The instrument contains a different software version. Do you want to reset it?

Cause: The application has discovered a different version of software operating in the analyzer.

Action: If there are no analyzers other than the ChemiSorb connected to the computer, select **Yes** and allow the updated software to load.

2533- Analyzer initialization failed.

Cause: An internal processing and/or hardware error has occurred.

Action: Contact your service representative if this message continues.

2534- Error opening file (name) for printing. Error code: (number).

Cause: An error occurred in the selected file for print output.

Action: Ensure that sufficient space is available on the drive containing the file.

2548- System status (n)

Cause: There was a problem establishing communication with the analyzer.

Action: Ensure that the communications cable is seated firmly in the ethernet slot at the analyzer connection and the computer connection.

Contact your service representative if this message continues.

2549- Error accessing online manual file (code #).

Cause: The operator's manual file could not be located.

Action A: Reinstall the application.

Action B: Copy the contents of the manual folder on the setup CD to the application directory.

2550- Attempts to acquire the instrument's status timed out.**2551- Unable to establish the TCP connection with the instrument.**

Cause: There was a problem establishing communication with the analyzer.

Action: Ensure that the communications cable is seated firmly in the ethernet slot at the analyzer connection and the computer connection.

Contact your service representative if this message continues.

2552- Configured serial number does not match instrument.

Cause: The serial number of the instrument is different from the one expected by the application.

Action: Run the setup program on the installation CD; select the **Remove** operation to remove the incorrect serial number. Then select the **Add** operation to add the correct serial number.

Contact your service representative if this message continues.

2554- File (name) does not contain any report data.

Cause: An attempt was made to open a previously saved report file but the file has no report data.

Action: Select a different file.

2556- Directory database (file name) error (code).

Cause: An internal software or computer has occurred.

Action: Navigate to the application directory and delete the file name shown in the message; the application will generate a new one.

Contact your service representative if this message continues.

4000 Series

4002- Thermal Transpiration correction had no effect.

Cause: The **Apply thermal transpiration correction** option was selected on the Report Options dialog. However, the correction did not change any pressure by more than one percent.

Action: Deselect to disable this message. This correction is only applicable for very low pressures.

4003- Error Converting Pressures.**4004- Error Computing Volume Adsorbed.**

Cause: An internal processing and/or hardware error occurred during report generation.

Action: Contact your service representative if this message continues.

4006- Report Type Not Found.**4007- Error Processing Report.**

Cause: An internal processing and/or hardware error occurred during report generation.

Action: Contact your service representative if this message continues.

4027- Fewer than two sample files have data suitable for heat of adsorption reports.

Cause: Less than two of the sample files selected for heat of adsorption reports contain appropriate data.

Action: Edit the Quantity Adsorbed table, or select other sample files.

4057- At least two data points are needed for Freundlich calculations.

Cause: Less than two data points have been selected for the Freundlich report; at least two are required.

Action: Select Freundlich points on the Collected Data dialog. If calculation assignments are not being used, edit the Freundlich Report options, **Absolute pressure range** in the sample file.

4058- At least two data points are needed for Temkin calculations.

Cause A: Less than two data points have been selected for the Temkin report; at least two are required.

Action A: Select Temkin points on the Collected Data dialog. If calculation assignments are not being used, edit the Temkin Report options, **Absolute pressure range** in the sample file.

Cause B: At least one point with a negative pressure value was selected to include in the Temkin report.

Action B: Negative pressure points void Temkin calculations. Open the sample file and click the **Collected Data** tab. Locate the negative value(s) in the Temkin column and deselect it (them).

4080- The compressibility factor table has [nn] pressure entries. Only [nn] are allowed.

Cause: The compressibility factor table in the adsorptive properties has too many pressure values for analysis.

Action: Edit the table to remove unneeded pressure entries.

4081- In the compressibility factor table, the 4 temperatures below [nn] and 7 temperatures above must span at least 10 K.

Cause: The compressibility factor table in the adsorptive properties has too many entries for temperatures near ambient.

Action: Edit the table to remove unneeded temperature entries.

4082- Compressibility factors must be greater than zero for temperatures near ambient and pressures up to the maximum manifold pressure.

Cause: The compressibility factor table in the adsorptive properties contains zeros or negative values for the temperatures and pressures expected during analysis.

Action: Edit the table to add missing compressibility factors.

4090- The compressibility factor table is empty.

Cause: The compressibility factor table in the adsorptive properties does not have any data.

Action: Load an appropriate compressibility factor table.

6000 and 6100 Series

6000- An error occurred while loading the application control information. Data entry cannot be performed. (Code number)

Cause: An error occurred accessing the control information disk file required by this application.

Action: The disk drive may have failed or be corrupt. Run diagnostics on the disk drive.

6056- The Psat gas must be the same as the analysis gas if Po is calculated from Psat and the analysis gas is dosed from the Psat tube.

Cause: Dosing from the Psat tube is selected in the adsorptive properties and the analysis conditions Po and temperature options specify that Po should be calculated from the Psat of a gas, but the Psat gas differs from the analysis gas.

Action: Select a gas for the Psat measurement that has the same mnemonic as the analysis gas. Typically the analysis and Psat gas will be krypton but the Psat gas will include the solid Psat vs. T table.

6102- The instrument (Unit n, SN NN) is not calibrated.

Cause: One or more calibration operations have not been performed.

Action: Using the setup CD, reinstall the calibration files. If this does not correct the problem, contact your Micromeritics representative.

6200 Series

6200- Could not construct (name) report type. Program will terminate.

Cause: An internal processing and/or hardware error has occurred.

Action: Contact your service representative if this message continues.

6203- File cannot be opened for editing. It is already in use.

Cause: The file specified is being used in another edit operation.

Action: Close the file in use and try to open the file again.

6210- Only one analysis task may be included in the analysis conditions.

Cause: An attempt was made to insert a second analysis task into the Selected Tasks list.

Action: If the analysis task is to be inserted at the current position in the task list, first delete the other analysis task.

6211- The gas selected for the (task name) task is different than the gas selected for the neighboring tasks. An evacuation task must be added to add this task. Add evacuation and proceed?

Cause: A new task was entered and the gas does not match the gas in the previous task. Mixing gases may be dangerous.

Action: Select **Yes** to automatically insert the evacuation task. Select **No** to continue editing the task options.

6212- A leak test is specified without a preceding evacuation. Do you wish to insert an evacuation task?

Cause: A task was inserted or deleted in the **Selected Tasks** list and left a leak test task without a preceding evacuation task. The leak test will fail if the sample pressure exceeds 0.5 mmHg.

Action: Select **Yes** to evacuate the sample between the two tasks. Select **No** if to not include evacuation

6213- The maximum allowed number of tasks is selected. Delete some tasks before proceeding.

Cause: An attempt was made to insert more than twenty tasks.

Action: Specify no more than twenty tasks in one sample file. If more preparation steps are required, use two sample files. The first sample file should contain only preparation tasks; the second file should contain any remaining preparation tasks and an analysis task.

6214- An analysis task is specified without a preceding evacuation. An evacuation task will be entered for you and you may edit it.

Cause: A task was inserted or deleted in the **Selected Tasks** list, leaving the analysis task without a preceding evacuation task.

Action: Edit the evacuation task accordingly.

6215- The Selected Tasks list contains adjacent tasks using different gases. Do you still wish to save this file?

Cause: An attempt was made to save a sample file in which one task in the **Selected Tasks** list uses a different gas than the previous/next task. Mixing gases may be dangerous.

Action: Select **No** to close the file without saving it. Return to the Analysis conditions dialog and insert an evacuation task between all flow, soak and analysis tasks which use different gases.

6216- The selected task has already been executed. It may not be changed or deleted.

Cause: An attempt was made to edit or delete a task after it was already performed.

Action: Edit or delete a task not yet performed.

6217- New tasks may only be inserted following task (number).

Cause: An attempt was made to insert a task before the task currently being executed.

Action: Insert new tasks following the task number specified in the message.

6218- An analysis task may not be inserted while an experiment is in progress.

Cause: An attempt was made to insert an analysis task in the **Selected Tasks** list for a sample file currently being processed by the analyzer.

Action: To not insert an analysis task, first cancel the experiment in progress. Then delete the tasks which had executed up to the time of the cancellation, insert an analysis task, and restart the experiment

6219- No new tasks may be inserted. Analysis is complete.

Cause: An attempt was made to insert a new task in the **Selected Tasks** list for a sample file which is currently being processed by the analyzer. All tasks have been processed and the analyzer is performing the termination sequence.

Action: Create a new sample file containing the tasks and submit it for processing.

6220- Tasks may not be deleted after an experiment has been started.

Cause: An attempt was made to delete a task from the **Selected Tasks** list after the sample file was submitted for analysis.

Action: Reduce the duration of the task to minimum value.

6222- (Unit n) (gas name) required by task (number) is not configured on the selected unit.

Cause: An attempt was made to start an analysis which requires a gas not entered in the unit configuration information. The analysis is canceled.

Action: Select **Unit [n] > Unit Configuration**; click **Gas** to display the Gas Configuration dialog and specify the valve to which the required gas is connected.

6223- Sample has no Analysis Task entry. Do you wish to proceed with the analysis?

Cause: An attempt was made to analyze a sample file with no analysis task entry.

Action: Select **No** to cancel the analysis, add an analysis task, and restart the analysis.

6224- Sample has no pressure table entries. Do you wish to proceed with the analysis?

Cause: An attempt was made to start an analysis using a sample file for which no pressure table was defined.

Action: Select **Yes** to proceed with the analysis; all preparation tasks and the free-space measurement are performed, but no data points are collected. Select **No** to cancel the analysis; enter a pressure table for the sample.

6225- The Selected Tasks list contains adjacent tasks using different gases. Do you still wish to close this file? (yes, no)

Cause: An attempt was made to close a file that has adjacent experiment tasks which specify different gases. Incompatible gases may be mixed during sample preparation.

Action: Select **No** if you do not want gases to be mixed on the sample. Select **Yes** to return to the Analysis conditions dialog and add evacuation tasks if necessary.

6226- (gas symbol) required for backfilling the sample at the end of the analysis is not configured on the selected unit.

Cause: The gas specified for use in backfilling the sample at the end of the experiment is not configured on the instrument.

Action: Select **Unit > Unit Configuration** to display the Unit Configuration dialog. Click **Gas** to display the Configuration Gas Options dialog; select the gas inlet port to which the required gas is connected.

6228- There is no helium attached to the unit. Free space will not be measured.

Cause: An attempt was made to start an analysis in which a measured free space was requested but a helium gas tank was not detected.

Action A: A helium tank was attached, but the port was not configured. Select **Unit [n] > Unit Configuration**, click the **Gas** button and assign helium (He) at the appropriate port.

Action B: A helium tank was not attached to the unit. Attach a helium tank, then select **Unit [n] > Unit Configuration**, click the **Gas** button and assign helium (He) at the appropriate port.

Action C: Perform the analysis without a measured free space.

6230- The Active Metals Table Options dialog does not specify a stoichiometry factor for the adsorptive (gas name) of the element (metal name). One (1.0) was substituted for this value in the calculations.

Cause: A non-zero percent of sample weight for an element in the Active Metals Table of the sample report options was specified but a stoichiometry factor for the adsorptive used in the analysis was not specified.

Action: The calculation proceeds with the default value and the program produces a report. Edit the sample information file to include the correct value and run the report again.

6231- No element in the Active Metals Table Options has a “% of Sample Weight” value greater than zero. Metallic Dispersion and Metallic Surface Area will not be calculated.

Cause: All elements in the Active Metals Table of the sample report options have the value zero entered for the percentage of sample weight.

Action: The calculations proceed and the program produces an incomplete report. Edit the sample information file to include the correct value and run the report again

6232- Sinfelt (Difference) Plot cannot be produced: Fewer than two data points were selected for inclusion in the calculations.

Cause: Fewer than two data points were selected for inclusion in the Sinfelt (or Difference) plot calculation. The plot requires at least two data points to be produced.

Action: Edit the sample information file to select the data points used in the calculation.

6234- Leak test failure - the observed outgas rate of [VAC0] [VAC-U] exceeds the limit of [VAC0] [VAC-U].

Cause: The outgas rate specified in the leak test criteria was exceeded.

Action: Check sample tube fitting to ensure that it is securely attached to the port. Then start the analysis again.

6235- Leak test failure in task (number): The sample was not fully evacuated prior to the test.

Cause: The sample was at a pressure greater than 0.5 mmHg at the start of the leak test. A leak test cannot be performed unless the sample has been fully evacuated.

Action: Insert an evacuation task into the **Selected Tasks** list immediately before the leak test. If an evacuation task is already present, ensure that the evacuation is being performed at the same temperature as the test and that the duration of the evacuation is adequate.

6236- Pressure exceeded [PR0] [PR-U] while flowing (gas).

Cause: The pressure in the manifold exceeded the indicated maximum, while flowing gas over the sample.

Action: Verify that the exhaust line is not plugged or restricted. Reduce the pressure of the flowing gas at the tank regulator. Resume the experiment while monitoring the manifold pressure and flow rate. Adjust the regulator pressure to achieve the flow rate with a manifold pressure of less than the indicated maximum.

6237- (Unit {number}) Analysis canceled in task (number): Time limit exceeded while attempting to reach temperature (number)C.

Cause A: The furnace has malfunctioned.

Action A: Contact your service representative.

Cause B: The pressure within the cooling line is too low.

Action B: Increase the pressure of the cooling gas to between 10 and 20 psi.

6238- Furnace is not in the raised position. This is not the recommended operating configuration. Do you wish to proceed with the analysis?

Cause: The elevator holding the furnace is not in the fully raised position. Unless a custom furnace or Dewar is being used, it is not the correct operating position.

Action: Select **No** to stop the analysis initialization; then correctly position the furnace. Select **Yes** if using custom equipment and are certain it is installed correctly.

6248- The selected task is currently executing. It may not be changed or deleted at this time.

Cause: An attempt was made to edit or delete a task which is currently in operation.

Action: None required for this task. For future reference, suspend the analysis to edit or delete a task.

6249- The sample file (number) is already present in the sequence.

Cause: An attempt was made to insert a sample file that is already in the sequence.

Action: Create or select another file.

6264- Calculations failed for first analysis data.**6265- Calculations failed for repeat analysis data.****6266- Calculations failed for differential data.**

Cause: The report could not be produced for the indicated data set. Additional messages on the error report provide more detail.

Action: See actions for the other error messages.

6267- Fewer than two repeat points are available.**6268- Fewer than two difference points are available.**

Cause: At least two points are required for calculations.

Action: Edit the calculation assignments for this report.

6269- Line fit could not be done for (primary, repeat, or difference) data.

Cause: The line fit for the Difference or Sinfelt report failed.

Action: Check that the data points are appropriate for fitting. See actions for other error messages on the report.

6500 Series

6500- Failed to evacuate manifold to VAC SET in (number of) seconds. Calibration canceled.

Cause A: The vacuum set point is set too low.

Action A: Reset VAC SET point to 5.0 mmHg. If the VAC SET point is already at 5.0 mmHg or above, the vacuum gauge may need servicing.

Cause B: Leak in manifold.

Action B: Locate the leak and repair it. See **Chapter 9, Troubleshooting and Maintenance**. Restart calibration.

Cause C: Valve failure.

Action C: Identify the leaking valve. Contact your service representative.

6504- Unable to write the calibration file (name).

Cause: A **Save to File** operation failed.

Action: Confirm there is sufficient free space on the media receiving the file and that the media is not corrupted. If the problem persists contact a Micromeritics service representative.

6505- Unable to read the calibration file (name).

6506- Calibration file for (file name) is invalid.

Cause: A **Load from File** operation failed.

Action: Confirm there is sufficient free space on the media receiving the file and that the media is not corrupted. If the problem persists contact a Micromeritics service representative.

6510- Main pressure transducer overrange detected.

Cause: A manifold pressure over 1000 mmHg was detected. The exhaust for the instrument or the exhaust port on a sample tube may be blocked.

Action A: Inspect for and clear any blockage.

Action B: Observe caution if operating the analyzer manually.

If the problem persists, contact a Micromeritics service representative.

6511- Sample transducer overrange detected.

Cause: A sample pressure over 960 mmHg was detected. The exhaust on a sample tube may be blocked.

Action A: Inspect for and clear any blockage.

Action B: Observe caution if operating the analyzer manually.

If the problem persists, contact a Micromeritics service representative.

6512- Time limit exceeded while dosing manifold to (pressure) with (gas).

Cause A: The maximum time was exceeded before the target pressure point was reached. The nitrogen regulator may be set too low or turned off.

Action A: Set the analysis gas regulator to 10 psig (0.7 bar). Then resume the analysis.

Cause B: The analysis gas bottle is empty.

Action B: Connect a new analysis gas bottle. Then resume the analysis.

6513- Time exceeded while evacuating manifold.

Cause A: Maximum manifold evacuation time was exceeded before the vacuum set point was achieved. Vacuum pump may be turned off.

Action A: Turn on vacuum pump switch. Then restart the analysis.

Cause B: The manifold is contaminated or leaking.

Action B: Correct the problem, then restart the analysis.

6514- Time limit exceeded while evacuating sample (servo).

Cause A: The maximum time for evacuating the sample through the servo was exceeded before the unrestricted evacuation pressure was achieved. Possible causes are a leak in the sample tube fitting or a crack in the sample tube.

Action A: Check the sample tube and the sample tube fitting; ensure that the tube is securely attached to the port. Then restart the analysis.

Cause B: The vacuum pump may be turned off.

Action B: Turn on the vacuum pump and restart the analysis.

6515- Time limit exceeded while evacuating sample (unrestricted).

Cause: The maximum time for evacuating the sample through the unrestricted valve was exceeded. Possible causes are a leak in the sample tube fitting or a crack in the sample tube.

Action: Check the sample tube and the sample tube fitting; ensure that the tube is securely attached to the port. Then restart the analysis.

6518- Servo calibration failed.

Cause A: The maximum time was exceeded before the target pressure point was reached. The nitrogen regulator may be set too low or turned off.

Action A: Set the analysis gas regulator to 10 psig (0.7 bar), then resume the analysis.

Cause B: The analysis gas bottle is empty.

Action B: Connect a new analysis gas bottle, then resume the analysis.

6519- Zero calibration failed.

Cause: A transducer offset measured after evacuation was out of tolerance.

Action: Repeat the calibration. Contact your service representative if this message continues.

6520- Match calibration failed.

Cause: A transducer scale measured after dosing to the match pressure was out of tolerance.

Action: Verify that the vacuum pump is operating properly, then repeat the calibration.

Contact your service representative if this message continues.

6521- Fill timeout while (task). Check the (gas) supply pressure and resume.

Cause A: The maximum time was exceeded while filling the sample tube and/or manifold with the specified gas. The gas regulator may be set too low or turned off.

Action A: Ensure that the gas regulator is in the **On** position and that is set to 22 psig (152 kPag), then resume the analysis.

Cause B: The gas bottle is empty.

Action B: Replace the gas bottle, then resume the analysis.

6522- Warning: Measured flow rate is out of tolerance on (Port n).

Cause: The mass flow rate during a flow task was over 10 cc/min above or below the requested rate.

Action: Ensure that the gas regulator for the flowing gas is set to 20 psig.

6523- Furnace cooling to (temp) time limit exceeded on (Port n).

Cause A: The furnace for the indicated port has malfunctioned.

Action A: Contact your service representative.

Cause B: The pressure within the cooling line is too low.

Action B: Increase the pressure of the cooling gas to between 10 and 20 psi.

6530- Analysis canceled: Bad thermocouple detected on (Port n). Caution: Use extreme care when handling the sample thermocouple and sample tube as the furnace and those components may be at an unsafe temperature.

Cause A: The thermocouple is unplugged.

Action A: Plug in the thermocouple and try again.

Cause B: The thermocouple has malfunctioned.

Action B: Replace the thermocouple.

6531- Analysis canceled: Sample or furnace temperature exceed limit on (Port n).

Cause: A sample or furnace temperature above the maximum allowed was reported. The thermocouple may have malfunctioned.

Action: Replace the thermocouple.

If the problem persists, contact a Micromeritics service representative.

6532- Analysis canceled: Port temperature exceed limit on (Port n).**6533- Analysis canceled: Manifold temperature exceed limit.**

Cause: A port or manifold temperature above 50 °C was reported. The manifold cooling vents may be obstructed.

Action: Ensure that nothing is obstructing the vents and that the cooling fans are operating properly.

6534- Analysis canceled: Temperature control enabled on (Port n) with elevator not in position.

Cause: The analysis on the specified port is temperature-controlled and the elevator has malfunctioned.

Action: Contact your Micromeritics service representative.

6535- Temperature control disabled on (Port n). Maximum (furnace or sample) temperature exceeded.

Cause: A sample or furnace temperature above the maximum allowed was reported.

Action: Replace the thermocouple.

If the problem persists, contact a Micromeritics service representative.

6536- Analysis canceled: Main pressure transducer overrange detected.

Cause: A manifold pressure over 1000 mmHg was detected. The exhaust for the instrument or the exhaust port on a sample tube may be blocked.

Action A: Inspect for and clear any blockage.

Action B: Observe caution if operating the analyzer manually.

If the problem persists, contact a Micromeritics service representative.

6537- Analysis canceled: Sample transducer overrange detected on (Port N).

Cause: A sample pressure over 960 mmHg was detected. The exhaust on a sample tube may be blocked.

Action A: Inspect for and clear any blockage.

Action B: Observe caution if operating the analyzer manually.

If the problem persists, contact a Micromeritics service representative.

6538- Analysis canceled: Sample pressure on (Port n) greater than [pressure] is not allowed.

Cause: A manifold pressure greater than the maximum allowed was attained during dosing.

Action: The analysis cancelled; data up to the point of cancellation have been stored.

6539- Analysis canceled: Time limit exceeded while waiting for the sample temperature on (Port n) to stabilize.

Cause: The maximum time to achieve the requested temperature was exceeded.

Action A: Ensure that the furnace insulator disk and the safety shield on the specified port are in place

Action B: Verify that the sample thermocouple is giving appropriate readings.

6540- Analysis canceled: Zero of the manifold transducer(s) failed.

6541- Analysis canceled: Zero of the (Port n) transducer(s) failed.

Cause: The offset value after calibration exceeded the recommended limit.

Action: Verify that the vacuum pump is operating correctly. Manually evacuate the manifold to ensure a proper vacuum is observed.

Contact your service representative if this message continues.

6542- Analysis canceled: Matching of sample transducer to manifold transducer on (Port n) failed.

6543- Analysis canceled: Matching of sample 1000 mmHg to 10 mmHg transducer on (Port n) failed.

Cause: The transducer did not respond correctly.

Action: Contact your Micromeritics service representative.

6544- Analysis canceled: Cumulative quantity dosed exceeded [quantity] on (Port n).

Cause A: More than the maximum allowed quantity has been dosed onto the sample; possibly due to leaks in the system.

Action A: Ensure that the sample tube is securely attached to the port, then restart the analysis.

Cause B: Too much sample may have been used.

Action B: Multiply the maximum value from the Quantity Adsorbed column of the Isotherm report by the sample mass. If the result exceeds the maximum quantity allowed, reduce the amount of sample and restart the analysis.

6545- Analysis canceled: Unknown gas requested.

Cause: An attempt was made to start an analysis using a sample information file in which the analysis gas specified does not match any gas connected to the analyzer.

Action: Connect the appropriate gas and specify its existence in the Unit configuration dialog or select another gas.

6546- Analysis canceled: Servo evacuation failed to maintain soak pressure.

Cause: Evacuation through the servo could not compensate for a rise in the sample pressure during a soak task.

Action A: Verify that the vacuum pump is operating properly.

Action B: Check the sample tube and the sample tube fitting; ensure that the tube is securely attached to the port.

6548- All samples must have analysis task.

Cause: An attempt was made to analyze a sample file with a sample file that does not have an Analysis task.

Action: Edit the **Selected Tasks** list in Analysis conditions so that it includes an Analysis task.

6549- All samples must have the same backfill gas.

Cause: The backfill gas in the indicated sample file is different from the other sample files chosen for the analysis.

Action: Edit the backfill gas selection in the sample file so that it matches the others.

6550- All samples must have the same number of tasks.

Cause: The number of tasks in the indicated sample file is different from the other sample files chosen for the analysis.

Action: Edit the **Selected Tasks** list in the sample file so that it matches the tasks in the others.

6551- All samples must have tasks in the same order.

Cause: The tasks in the indicated sample file are in a different order than those in the other sample files chosen for the analysis.

Action: Edit the **Selected Tasks** list so that are in the same order as those in the others.

6553- All (task name) tasks with temperature control enabled must have the same temperature and rate.

Cause: The indicated sample has a task with temperature settings that are different from the corresponding task in the other samples chosen for the analysis.

Action: Edit the task list in the sample file so that it uses the same settings as the other samples.

6554- All tasks must have the same 'evacuate for' and 'below' values.

Cause: The indicated sample has a task with evacuation settings that are different from the corresponding task in the other samples chosen for the analysis.

Action: Edit the task list in the sample file so that it uses the same settings as the other samples.

6555- All Soak tasks must have the same time and minimum pressure.

Cause: The indicated sample has a task with soak settings that are different from the corresponding task in the other samples chosen for the analysis.

Action: Edit the task list in the sample file so that it uses the same settings as the other samples.

6556- All Flow tasks must have the same time.

Cause: The indicated sample has a task with a Flow duration that is different from the corresponding task in the other samples chosen for the analysis.

Action: Edit the task list in the sample file so that it uses the same duration as the other samples.

6557- This file is already selected for the analysis.

Cause: An attempt was made to select a file for analysis that is already selected for another port.

Action: Select or create a different file.

6558- Gas (mnemonic) in sample file (file name) does not match any gas in the unit.

Cause: An attempt was made to start an analysis which requires a gas not entered in the unit configuration information. The analysis is canceled.

Action A: Select another gas.

Action B: Select **Unit [n] > Unit Configuration**; click **Gas** to display the Gas Configuration dialog and specify the valve to which the required gas is connected.

6559- Gas (mnemonic) in sample file (file name) does not match any gas in the Gas Defaults.

Cause: The properties for a gas needed for the analysis are not in the Gas Defaults table.

Action: Select **Options > Gas Defaults/MFC Constants** from the main menu and add the gas properties.

6560- None of the requested quantities adsorbed is within the range of the primary data of more than one sample file.

6561- None of the requested quantities adsorbed is within the range of the repeat data of more than one sample file.

6562- None of the requested quantities adsorbed is within the range of the different data of more than one sample file.

Cause: The Heat of Adsorption report could not be produced because the specified quantities adsorbed lie outside of the range of the collected data in the selected sample files.

Action A: Adjust the entries in the table of quantities adsorbed.

Action B: Exclude primary, repeat, or difference data from the report.

6563- The sample (file name) does not have enough primary data. A minimum of two adsorption points is required.

6564- The sample (file name) does not have enough repeat data. A minimum of two adsorption points is required.

6565- The sample (file name) does not have enough difference data. A minimum of two adsorption points is required.

Cause: The Heat of Adsorption report could not be produced because the specified sample files do not have enough data.

Action A: Select files with more data.

Action B: Exclude primary, repeat, or difference data from the report.

- 6566- The sample (file name) does not have any primary data in the range of the requested quantities adsorbed.**
- 6567- The sample (file name) does not have any repeat data in the range of the requested quantities adsorbed.**
- 6568- The sample (file name) does not have any difference data in the range of the requested quantities adsorbed.**

Cause: The specified quantities adsorbed lie outside of the range of the collected data in the indicated sample file. That file's data will not be used. The report will still be produced if at least two other files have appropriate data.

Action A: Adjust the entries in the table of quantities adsorbed.

Action B: Exclude primary, repeat, or difference data from the report.

- 6569- No data sets are selected.**

Cause: All data sets were excluded from the report.

Action: Include primary, repeat, or difference data in the report.

- 6570- No reports sets are selected.**

Cause: None of the Heat of Adsorption reports were selected.

Action: Select the Tabular report, Isostere report, or the Heat of Adsorption report.

B. CALCULATIONS

This appendix contains the calculations used in the ChemiSorb program.

Real Gas Equation of State

All gas accounting calculations in the ChemiSorb HTP utilize the real gas equation of state and compressibility factor data traceable to NIST.

$$n = \frac{PV}{z(P,T)T}$$

Where:

n	=	quantity of gas
P	=	pressure
T	=	temperature
V	=	volume
$z(P,T)$	=	compressibility factor for the gas of interest at the given pressure and temperature.

Quantity of gas in cm³ STP is given by

$$Q = n \frac{T_{STD}}{P_{STD}}$$

Free Space

The free space is the physical volume below the sample valve. The different temperatures in the sample tube, stem, and port must be accounted for.

Free-space volumes are calculated using the following equations:

$$n_p = \frac{P_s V_p}{z(P_s, T_p) T_p}$$

$$n_s = n_d - n_p$$

$$V_s = \frac{n_s z(P_s, T_s) T_s}{P_s}$$

The reported free space is:

$$V_f = V_p + V_s$$

The quantity of gas in the free space for a given data point is:

$$n_p = P_s \left(\frac{V_p}{z(P_s, T_p) T_p} + \frac{V_s}{z(P_s, T_s) T_s} \right)$$

Where:

n_d	=	quantity of gas dosed
n_p	=	quantity of gas in the port
n_s	=	quantity of gas in the sample tube
P_s	=	sample (and port) pressure
T_p	=	port temperature
T_s	=	sample temperature
V_p	=	volume of the sample port
V_s	=	volume of the sample tube
$z(P, T)$	=	gas compressibility factor at pressure P and temperature T for the gas used

Quantity Adsorbed

A portion of the dosing volume may be at a slightly elevated temperature due to heating of the sample ports. So the manifold volume is partitioned into a volume at the temperature of the manifold block and a volume at the average temperature of the ports.

$$n_a = n_d - n_f$$

$$n_d = P_{1m} C(P_{1m}, T_{1m}, \bar{T}_{1p}) - P_{2m} C(P_{2m}, T_{2m}, \bar{T}_{2p})$$

$$C(P, T_m, T_p) = V_m \left(\frac{\alpha}{z(P, T_m) T_m} + \frac{\beta}{z(P, T_p) T_p} \right)$$

Where:

n_a	=	quantity of gas adsorbed
n_d	=	quantity of gas dosed
n_f	=	quantity of gas in the free space
P_{1m}	=	manifold pressure before dosing onto the sample
P_{2m}	=	manifold pressure after dosing
T_{1m}	=	manifold temperature before dosing onto the sample
T_{2m}	=	manifold temperature after dosing
\bar{T}_{1p}	=	average of all port temperatures before dosing onto the sample
\bar{T}_{2p}	=	average of all port temperatures after dosing
V_m	=	volume of the dosing manifold
α and β	=	constants that determine the relative weights of the manifold and port temperatures

Weighted Metal Parameters

The stoichiometry factor, atomic weight, and density used in calculations are averages weighted by the number of moles of each active metal. For example, the average stoichiometry factor is

$$\bar{S} = \frac{\sum_i n_i S_i}{\sum_i n_i}$$

Where:

n_i = number of moles of metal,

$$n_i = \frac{\alpha \beta X}{XW_m + YW_o}$$

where:

α = fraction of sample weight

β = fraction reduced

X = number of metal atoms in the oxide

Y = number of oxygen atoms in the oxide

W_m = Atomic weight of metal

W_o = Atomic weight of Oxygen

Average density and atomic cross-sectional area are calculated similarly.

Difference and Sinfelt Methods

The y-intercept quantity adsorbed (Q_0) is used for several calculations in the difference and Sinfelt reports. This value can be determined in two ways. If one point selected, Q_0 is the quantity adsorbed for that point.

Difference

The repeat isotherm data are subtracted from the primary isotherm. Q_0 is the y-intercept of a straight line through the difference data.

Sinfelt

Both the primary and repeat isotherms are fitted to a straight line. Q_0 is the difference between the y-intercepts of the fit lines.

Metal Dispersion

$$D = 100\% \cdot 100\% \frac{Q_0 \bar{S}}{V_{mol} \sum_i \frac{P_i}{w_i}}$$

Where:

$V_{mol} \simeq 22414 \text{ cm}^3/\text{mol}$; the molar volume of an ideal gas at standard temperature and pressure

Metallic Surface Area

The metallic surface area is the total active metal surface area available for interaction with the adsorbate.

$$A_{metal} = \frac{N_A Q_0 \bar{S} A_{atom}}{V_{mol}}$$

Where:

$N_A \simeq 6.023 \times 10^{23}$ the number of atoms per mole

Crystallite Size

$$d_{xtal} = \frac{1000k}{\bar{\rho} A_{metal}}$$

Where:

$\frac{k}{\bar{\rho}}$ = shape factor; 6 for sphere, 5 for cube
 = weighted average density of the active metals

Langmuir Surface Area

Transform

The Langmuir isotherm is:

$$\frac{Q}{Q_m} = \frac{bP}{1 + bP}$$

The isotherm is transformed so that P/Q is plotted as a function of pressure. The transformed data are fitted with a straight line. the slope (m) and intercept (y_0) of the fit line are used in the calculations below.

Surface Area

$$A_{Lang} = \frac{\bar{A}_{atom} \bar{S} N_A}{V_{mol} m} \cdot 10^{-18} \frac{m^2}{nm^2}$$

Monolayer Capacity

$$Q_m = \frac{1}{m}$$

Langmuir b Value

$$b = \frac{1}{y_0 Q_m}$$

Dissociative Chemisorption

The Langmuir isotherm may be derived for dissociative chemisorption.

$$\frac{Q}{Q_m} = \frac{b\sqrt{P}}{1 + b\sqrt{P}}$$

The calculations are performed with the slope and intercept of a fit of $\frac{\sqrt{P}}{Q}$ as a function of \sqrt{P} .

Freundlich Isotherm

The Freundlich isotherm has the form:

$$\frac{Q}{Q_m} = CP^{1/m}$$

where

- Q = quantity of gas adsorbed
- Q_m = quantity of gas in a monolayer
- C = temperature-dependent constant
- m = temperature-dependent constant

The pressure is absolute; typically, $m > 1$. In terms of quantity adsorbed,

$$Q = Q_m CP^{1/m}$$

Taking the log of both sides yields:

$$Q = Q_m C + \frac{1}{m} P$$

Temkin Isotherm

The Temkin isotherm has the form,

$$\frac{Q}{Q_m} = \frac{RT}{q_0\alpha} \ln(A_0P)$$

where

- Q = quantity of gas adsorbed
- Q_m = quantity of gas in a monolayer
- q_0 = the differential heat of adsorption at zero surface coverage
- A = $a_0 \exp \{-q_0/RT\}$, where α_0 and a_0 are adjustable constants

In terms of quantity adsorbed,

$$Q = \frac{RTQ_m}{q_0\alpha} (\ln A_0 + \ln P)$$

Thus, the plot of the natural log of absolute pressure vs. quantity adsorbed yields a straight line with slope RTQ_m/q_0 and intercept $(\ln A) RTQ_m/q_0\alpha$.

C. GAS CONVERSION CONSTANTS

The ChemiSorb analyzer uses Mass Flow Controllers (MFCs) to control the flow of gases. These MFCs require a conversion constant for each gas or gas mixture, to compensate for variations in gas flows resulting from variations in the gases' properties. A default gas table containing MFC conversion constants is included on the Options menu. The following table provides a more complete list of gases and their conversion constants.

To determine a new conversion constant if using a unique gas mixture, see [Gas Mixtures](#), page [C-5](#))

Gas Conversion Constants for the MFC

Gas	Symbol	MFC Conversion Constant (H ₂ = 1.000)
Acetylene	C ₂ H ₂	0.6535
Air (mixture)		0.9901
Allene	C ₃ H ₄	0.4752
Ammonia	NH ₃	0.7822
Argon	Ar	1.3861
Arsine	AsH ₃	0.7525
Boron Trichloride	BCl ₃	0.4356
Boron Trifluoride	BF ₃	0.5743
Bromine Pentafluoride	BrF ₅	0.2871
Bromine Trifluoride	BrF ₃	0.4356
Butane	C ₄ H ₁₀	0.2871
Butene	C ₄ H ₈	0.3267
Carbon Dioxide	CO ₂	0.7723
Carbon Monoxide	CO	0.9802
Carbon Tetrachloride	CCl ₄	0.3465
Carbon Tetrafluoride	CF ₄	0.4752
Carbonyl Fluoride	COF ₂	0.2673
Carbonyl Sulfide	COS	0.6733
Chlorine	Cl ₂	0.8218
Chloroform	CHCl ₃	0.4356
Chlorine Trifluoride	ClF ₃	0.4257
Cyanogen	C ₂ N ₂	0.4950
Cyclopropane	C ₃ H ₆	0.5050
Deuterium	D ₂	0.9901

Gas Conversion Constants for the MFC (continued)

Gas	Symbol	MFC Conversion Constant (H ₂ = 1.000)
Diborane	B ₂ H ₆	0.5446
Dichlorosilane	SiH ₂ Cl ₂	0.4356
Dimethylamine	(CH ₃) ₂ NH	0.6634
Dimethylether	(CH ₃) ₂ O	0.5842
Ethane	C ₂ H ₆	0.5446
Ethyl Chloride	C ₂ H ₅ Cl	0.2871
Ethylene	C ₂ H ₄	0.6139
Ethylene Oxide	C ₂ H ₄ O	0.5842
Fluorine	F ₂	0.9208
Fluroform	CHF ₃	0.5644
Freon 11	CCl ₃ F	0.3762
Freon 12	CCl ₃ F ₂	0.3861
Freon 13	CClF ₃	0.4257
Freon 13 B1	CBrF ₃	0.4059
Freon 14	CF ₄	0.4703
Freon 21	CHCl ₂ F	0.4554
Freon 22	CHClF ₂	0.5050
Freon 23	CHF ₃	0.5644
Freon 113	CCl ₂ F-CClF ₂	0.2277
Freon 114	CCl ₂ F ₄ -CClF ₂	0.2554
Freon 115	CClF ₂ -CF ₃	0.2713
Freon 116	CF ₃ -CF ₃	0.2277
Germane	GeH ₄	0.6436
Helium	He	1.3762
Hexamethyldisizane	HMDS	0.1386
Hydrogen	H ₂	1.0000
Hydrogen Bromide	HBr	0.9703
Hydrogen Chloride (Dry)	HCl	0.9802
Hydrogen Fluoride	HF	0.9901
Hydrogen Iodide	HI	0.9505
Hydrogen Selenide	H ₂ Se	0.8317
Hydrogen Sulfide	H ₂ S	0.8416

Gas Conversion Constants for the MFC (continued)

Gas	Symbol	MFC Conversion Constant (H ₂ = 1.000)
Isobutane	C ₄ H ₁₀	0.3069
Isobutylene	C ₄ H ₈	0.3366
Krypton	Kr	1.3762
Methane	CH ₄	0.8020
Methylamine	CH ₃ NH ₂	0.5644
Methyl Bromide	CH ₃ Br	0.6436
Methyl Chloride	CH ₃ Cl	0.6832
Methyl Fluoride	CH ₃ F	0.7525
Methyl Mercaptan	CH ₄ S	0.5842
Neon	Ne	1.3861
Nitric Oxide	NO	0.9901
Nitrogen	N ₂	0.9950
Nitrogen Dioxide	NO ₂	0.7525
Nitrogen Trioxide	N ₂ O ₃	0.4356
Nitrogen Trifluoride	NF ₃	0.5446
Nitrous Oxide	N ₂ O	0.7426
Oxygen	O ₂	0.9802
Ozone	O ₃	0.7327
Pentaborane	B ₅ Hg	0.2871
n Pentane	C ₅ H ₁₂	0.2376
Perchloryl Fluoride	ClO ₃ F	0.4455
Phosgene	COCl ₂	0.5050
Phosphine	PH ₃	0.7822
Phosphorous Pentafluoride	PF ₅	0.3465
Propane	C ₃ H ₈	0.3861
Propylene (Propene)	C ₃ H ₆	0.4653
Silane	SiH ₄	0.6733
Silicon Tetrachloride	SiCl ₄	0.3168
Silicon Tetrafluoride	SiF ₄	0.3960
Sulfur Dioxide	SO ₂	0.7228
Sulfur Hexafluoride	SF ₆	0.2970
Trichlorosilane	Cl ₃ HS _i	0.3267
Trimethylamine	(CH ₃) ₃ N	0.3168

Gas Conversion Constants for the MFC (continued)

Gas	Symbol	MFC Conversion Constant (H₂ = 1.000)
Tungsten Hexafluoride	WF ₆	0.2871
Uranium Hexafluoride	UF ₆	0.2178
Vinyl Bromide	C ₂ H ₃ Br	0.5248
Vinyl Chloride	C ₂ H ₃ Cl	0.5347
Vinyl Fluoride	C ₂ H ₃ F	0.5743
Xenon	Xe	1.3762

Gas Mixtures

A conversion constant for a mixture of gases can be determined easily using the conversion constants for each gas in the mixture.

- Record the names and constants for each gas in the mixture.

Gas Name	Conversion Constant
1.	
2.	
3.	
4.	
5.	
6.	
7.	
8.	
9.	
10.	

- Use the following formula to calculate the conversion constant for the gas mixture.

$$M = \frac{1}{\left[\frac{P_1}{F_1 \times 100} \right] + \left[\frac{P_2}{F_2 \times 100} \right] + \dots + \left[\frac{P_n}{F_n \times 100} \right]}$$

M = the mixture conversion constant

P = the percentage of gas n in the mixture, expressed as a whole number
(example: for 15%, use 15, not .15)

F = the conversion constant (factor) for gas n

- Enter the gas mixture in the Gas Defaults table; use M as the conversion constant.

Mixture name: _____ Constant: _____

D. ATOMIC WEIGHTS AND CROSS-SECTIONAL AREAS FOR SELECTED METALS

Metal	Symbol	Atomic Weight (g/mole)	Cross-Sectional Area (sq nm)	Density (g/mL)
chromium	Cr	51.996	0.0635	7.19
cobalt	Co	58.933	0.0662	8.9
copper	Cu	63.546	0.0680	8.96
gold	Au	196.967	0.08696	18.9
hafnium	Hf	178.490	0.0862	13.3
iridium	Ir	192.220	0.0769	22.4
iron	Fe	55.847	0.0613	7.89
manganese	Mn	54.938	0.0714	7.43
molybdenum	Mo	95.940	0.0730	10.2
nickel	Ni	58.710	0.0649	8.8
niobium	Nb	92.906	0.0806	8.57
osmium	Os	190.220	0.0629	22.6
palladium	Pd	106.400	0.0787	12.0
platinum	Pt	195.090	0.0800	21.4
rhenium	Re	186.207	0.0649	21.0
rhodium	Rh	102.906	0.0752	12.4
ruthenium	Ru	101.070	0.0613	12.4
silver	Ag	107.868	0.0869	10.5
tantalum	Ta	180.947	0.0800	16.6
thorium	Th	232.038	0.1350	11.7
tin	Sn	118.710	0.1082	4.54
tungsten	W	183.850	0.0741	19.3
vanadium	V	50.942	0.0680	6.11
zirconium	Zr	91.220	0.0877	6.51

E. FORMAT OF EXPORTED DATA

This appendix details the format and meaning of data in unreduced reports. Each record is terminated by a carriage return and line feed. Character strings are delimited by double quotation marks.

Record position indicates the relative position of a record within a group. The different types of counter records indicate those sections of the file having a variable number of records; counter records specify the number of entries (types of information) contained in a table.

Record Position	Information Conveyed	Form
1	Sample ID	quoted string (40 characters)
2	Operator ID	quoted string (40 characters)
3	Submitter ID	quoted string (40 characters)
4	Bar code	quoted string (40 characters)
5	Mass	floating point
6	Type of data 0 = Automatically collected 1 = Manually entered	integer
7	Count of data points for primary analysis <i>(Each entry for this counter appears on one line, separated with a comma.)</i> Pressure value Quantity dosed Elapsed time Sample temperature Port temperature Assignments 1 = Difference report 2 = Sinfelt 3 = Both 4 = Neither Count of data points for repeat analysis Same columns as primary analysis	integer floating point floating point integer floating point floating point integer

INDEX

Symbols

\$ symbol, 8-8

A

Active metals

defaults, 8-12

Active Metals Defaults command, 8-12

Active metals table

options, 5-27

Add Log Entry button, 5-7

Adding an analyzer, 4-6

Adsorptive, 5-19

options, 8-13

Stoichiometry factor, 5-28, 8-13

Adsorptive button, 8-13

Advanced format, 8-3

sample information file, 3-9, 5-5

specifying default values, 8-6

Analysis

performing, 3-22

preparing for, 3-12

repeat, 5-20

sequence, 3-23

temperature, 5-19

termination, 5-14

Analysis conditions file, 5-12

creating, 3-6

listing file statistics, 2-7

listing statistics, 3-27

opening, 2-7

printing contents, 3-25

Analysis program, 1-4

exiting, 2-7

uninstalling, 4-16

using, 2-6

Analysis Sequence command, 6-8

Analyzer

adding another, 4-6

changing ethernet connection, 4-13

cleaning, 9-4

electrical requirements, 1-5

maintaining, 9-2

moving from one computer to another, 4-8

physical dimensions, 1-5

removing, 4-12

specifications, 1-5

turning on and off, 2-5

weight and dimensions, 1-5

ASCII format

saving reports, 7-11

Atomic cross-sectional area, 5-27

for metals, D-1

Atomic weight, 5-27

for metals, D-1

Autoscale

axes, 5-31

onscreen graphs, 7-14

Axis

coordinates, viewing, 7-17

properties, editing, 7-16

Axis Properties dialog, 7-16

B

Backfill

gas, 5-13

sample tube, 5-14

Bar code, 5-6

Basic format, 8-4

sample information file, 3-10, 5-8

C

Calculations

crystallite size, B-5

dissociative chemisorption, B-6

free space, B-1

Freundlich, B-7

gas quantities, B-1

Langmuir surface area, B-6

metal dispersion, B-5

metallic surface area, B-5

quantity adsorbed, B-3

Temkin isotherm, B-8

weighted metal parameters, B-4

Calibrate Pressure Offset dialog, 6-26

Calibrate Servo dialog, 6-27

Calibration, 6-26

match transducers, 6-27

MFC, 8-14

readings, 6-24

servo valve, 6-27

Calibration file

loading, 6-28

reinstalling, 4-15

Cascade windows, 2-7, 2-9
Cautions, defined, 1-3, 4-5
Cleaning
 analyzer, 9-4
 sample tubes, 3-12
Clear button, 5-22
Close command, 5-44
Columns, editing on onscreen reports, 7-13
Compatibility check, 6-4
Components and Connectors, 2-1
 front panel, 2-1
 rear panel, 2-3
 side panel, 2-4
Compressibility
 factor, 8-15
Computer requirements, 1-7
Conventions
 file name, 2-7
 used in operator's manual, 1-3
Creating
 Analysis conditions files, 3-6, 5-12
 Report options files, 3-7, 5-25
 Sample information files, 3-9, 5-4
 sample information files, 5-4
Cross hair, axis, 7-17
Curve Properties dialog, 7-15

D

Data
 collected, 5-41
 copy to clipboard, 7-16
 entered manually, 5-41
 isotherm, exporting, 5-48
 selecting display options, 8-16
Defaults
 Advanced format, 8-6
 Basic and Restricted formats, 8-9
 file name extensions, 2-7
 for parameter files, 8-6
 gas, 8-14
 sample file sequence number, 8-7
Delete button, 5-22
Difference Method report, 5-32
Directory
 parameter files, 8-17
Dose amount, 5-20

E

Edit Quantities Adsorbed dialog, 7-6
Element, 5-27
Elevator
 buttons, 2-2

 lubricating drive assembly, 9-3
 raising and lowering, 2-2, 6-15
Enable Manual Control command, 6-13
Environment conditions, 1-5
Equilibration, 5-23
Error messages, A-1
 2200 and 2400 Series, A-1
 2500 series, A-12
 4000 series, A-20
 6200 series, A-24
 6500 series, A-32
Evacuation, 5-15
 backfill gas, 5-13
 heat rate, 5-15
 task, 5-14
 temperature, 5-15
 time, 5-15, 5-21, 5-24
Exhaust system, attaching, 2-3
Exit command, 5-51
Export command, 5-48
Export data, 5-48
 format used, E-1
Exporting sample files, 3-29

F

File
 opening, 2-7
 statistics, 3-27
File menu, 5-1
 Export command, 5-48
 Open command, 5-3
 Save as command, 5-44
 Save command, 5-44
File name
 default extensions, 2-7
 included as part of file description, 8-7
Filler rod, 3-14
 cleaning, 3-12
Filter disks, 3-16
Flow
 gas, 5-16
 temperature, 5-16
 time, 5-16
Free space, 5-24
 calculations, B-1
 measurement, 5-24
Freundlich report, 5-36
 calculations, B-7
Front Panel, 2-1
Function keys
 See Shortcut keys
Furnace, raising and lowering, 2-2, 6-15

G

Gas

- connecting, 9-9
- conversion constant, 8-14
- conversion constants, list of, C-1
- disconnecting depleted bottle, 9-9
- for soaking, 5-18
- guidelines for connecting to analyzer, 9-9
- inlets, 2-4
- specifying ports for, 6-25, 9-13

Gas Configuration dialog, 6-25

Gas Defaults / MFC Constants command, 8-14

Graph

- copy to clipboard, 7-16
- editing onscreen, 7-14
- legend, editing, 7-16

Graph Grid Lines command, 8-16

Graph Grid Lines dialog, 8-16

Graph overlay, 3-31, 5-26

Graphic, showing in report header, 5-29

Grid lines, 8-16

H

Heat of Adsorption report, 2-7, 7-5

Help menu, 2-9

Histogram, 7-15

I

Insert button, 5-22

Insert Quantity Range dialog, 7-6

Instrument log, showing, 6-22

Instrument schematic, 6-18

- component descriptions, 6-13

Isothermic heat of adsorption, 7-5

Isotherm data, 5-48

- example of output, 5-50

Isotherm report, 5-30

L

Langmuir Surface Area report, 5-35

Leak test, 5-16

- task options, 5-16

Legend Properties dialog, 7-16

List command, 5-47

Log entry, 5-7

Log report, 6-22

M

Main menu, 2-8

Maintenance, system, 9-1

Manifold temperature, on schematic, 6-16

Mass Flow Controller, 1-4, 6-16

See also MFC

Menu structure, 2-8

MFC

calibration, 8-14

gas conversion constant, 8-14

gas conversion constants list, C-1

Monolayer capacity, 5-36, 5-38

Moving an analyzer to another computer, 4-8

N

Notes, defined, 1-3, 3-18, 5-6

O

Online manual

accessing, 2-7

Onscreen report, 7-9

editing, 7-13

saving, 7-11

shortcut menus, 7-13

See also Report

Open Compressibility Factor Table dialog, 8-15

Open Report command, 7-4

Operator, specifying, 8-7

Operator's manual

conventions, 1-3

organization, 1-1

Option presentation

Advanced format, 8-3

Basic format, 8-4

Restricted format, 8-5

Option Presentation command, 8-2

Options menu, 8-1

Active Metals Defaults command, 8-12

Gas Defaults / MFC Constants command, 8-14

Graph Grid Lines command, 8-16

Option Presentation command, 8-2

Parameter Files Directory command, 8-17

Service Test Mode command, 8-17

Thermal Transpiration on Live Graph command,
8-17

Units command, 8-16

Options report, 5-40

Outgas rate, 5-17

Overlay samples check box, 5-30

Overlay, graph, 3-31

P

Parameter File Directory Selection dialog, 8-17

Parameter files, 5-4

Analysis conditions, 5-12

default values, 3-1

defining, 3-6

directory, 8-17

listing statistics, 3-27

printing contents, 3-25

specifying location, 8-17

Password

Restricted format, 8-5

Service tests, 8-17

Port

assignment, 6-25

filter, replacing, 9-6

status, 2-2

Pressure

offset, 6-26

table, 5-21

Pressure button, 5-21

Pressure zero calibration, 6-26

Preventive maintenance schedule, 9-2

Print command, 5-45

Printing file contents, 3-25, 5-45

Q

Quartz wool, 3-16

R

Rear panel, 2-3

Removing an analyzer, 4-12

Repeat analysis, 5-20

Replace All button, 5-7

Replace button, 5-12

Report

closing all, 2-7

examples, 7-18

generating, 7-2

graphs, editing onscreen, 7-14

header, 7-9

Heat of Adsorption, 7-5

legend, editing, 7-16

onscreen, 7-9

opening, 7-4

saving in other formats, 7-11

starting, 2-7

Tabular, editing onscreen, 7-13

Tool bar, 7-10

zoom feature, 7-17

Report after analysis, 6-5

Report options file, 5-25

creating, 3-7

listing statistics, 2-7, 3-27

opening, 2-7

printing contents, 3-25

Report Settings dialog, 6-5

Reports

difference method, 5-32

Freundlich, 5-36

isotherm, 5-30

Langmuir surface area, 5-35

Options, 5-40

options, 5-40

Sample log, 5-40

Sinfelt method, 5-34

Temkin, 5-38

types available, 5-26

Reports menu, 7-1

Start Report command, 7-2

Restricted format, 8-5

password, 8-5

sample information file, 3-10, 5-11

S

Sample

determining mass of, 3-15

mass, 5-6

monolayer capacity, 5-36

Sample defaults, 8-6

Advanced format, 3-1, 8-6

Basic and Restricted formats, 3-3

Restricted format, 8-9

specifying for Advanced format, 8-6

specifying for Basic format, 8-9

Sample file name, specifying default sequence, 8-7

Sample information file, 5-4

Advanced format, 3-9, 5-5

Basic format, 3-10, 5-8

exporting, 3-29

listing statistics, 2-7, 3-27

opening, 2-7

printing contents, 3-25

Restricted format, 5-11

specifying defaults, 8-6

Sample log entry, 5-7

Sample Log report, 5-40

Sample tube

cleaning and labeling, 3-12

installing, 3-19

replacing O-ring, 9-4

Save As command, 5-44

Save command, 5-44

Schematic

- accessing pop-up menus, 6-13
 - manual control, 6-13
 - See also* Instrument schematic
- Select a Task dialog, 5-13
- Select Calibration File dialog, 6-28
- Sequence
 - analysis, 3-23
 - number, specifying, 8-7
- Service Test Mode command, 8-17
- Servo valve
 - calibrating, 6-27
 - settings, 6-14
- Set Temperature Controller dialog, 6-15
- Setup program, 4-4
 - adding an analyzer, 4-6
 - changing analyzer setup, 4-13
 - moving an analyzer to another computer, 4-8
 - reinstalling calibration files, 4-15
 - removing an analyzer from the computer, 4-12
 - uninstalling the software, 4-16
- Shortcut keys, 2-6
 - for instrument schematic, 6-13
- Shortcut menu, 2-6
 - accessing, 2-7
 - for graphs, 7-14
 - for tabular reports, 7-13
- Show All Readings command, 6-19
- Show Instrument Log command, 6-22
- Show Instrument Schematic command, 6-18
- Side panel, 2-4
- Sinfelt Method report, 5-34
- Soak task, 5-18
- Software
 - installing, 4-1
 - installing upgrade, 4-5
 - uninstalling, 4-16
 - using, 2-6
 - using for other functions, 4-4
 - version, 6-24
- Specifications, 1-5
- Spreadsheet format
 - saving reports, 7-11
- Start Report command, 7-2
- Start Report dialog, 7-2
- Status window, for analyses, 6-20
- Stoichiometry factor, 5-28
- Submitter, specifying, 8-7
- System
 - description, 1-4

T

- Target pressure tolerance, 5-20
- Task

- Analysis, 5-19
- Evacuation, 5-14
- Flow, 5-16
- inserting, 5-13
- Leak test, 5-16
- Soak, 5-18
- Temkin report, 5-38
 - calculations, B-8
- Temperature
 - manifold, 6-16
 - readings on schematic, 6-15
 - specifications, 1-5
- Thermal transpiration
 - correction, 5-28
 - on live graph, 8-17
- Tile windows, 2-7, 2-9
- Title Properties dialog, 7-16
- Tool bar, reports window, 7-10
- Transducer
 - match, 6-27
 - offset, 6-26
- Troubleshooting, 9-1

U

- Unit menu, 6-1
 - Analysis Sequence command, 6-8
 - Enable Manual Control command, 6-13
 - Sample Analysis command, 6-3
 - Show All Readings command, 6-19
 - Show Instrument Log command, 6-22
 - Show Instrument Schematic command, 6-18
- Units command, 8-16
- Units Selections dialog, 8-16
- Unrestricted evacuation, 5-15

V

- Valves
 - manual control, 6-13
 - servo, 6-14
- Volume calibration, 6-24

W

- Warnings, defined, 1-3
- Windows menu, 2-9

X

- X-axis range, 5-31
- X-axis scale, 5-30

Y

Y-axis range, [5-31](#)

Z

Zoom feature, [7-17](#)