

GEMINI VII 2390

UPGRADE FROM 2390A TO 2390P



UPGRADE INSTRUCTIONS

239-42810-00
Mar 2020
(Rev A)

TRADEMARKS

Gemini is a registered trademark of Micromeritics Instrument Corporation.

Microsoft and Windows are registered trademarks of Microsoft Corporation.

Micromeritics is a registered trademark of Micromeritics Instrument Corporation.

Copyright

The software described in this manual is furnished under a license agreement and may be used or copied only in accordance with the terms of the agreement.

CORPORATE PROFILE

Micromeritics Instrument Corporation is a leading global provider of solutions for material characterization with best-in-class instrumentation and application expertise in five core areas: density; surface area and porosity; particle size and shape; powder characterization; and catalyst characterization and process development.

Founded in 1962, the company is headquartered in Norcross, Georgia, USA and has more than 400 employees worldwide. With a fully integrated operation that extends from a world class scientific knowledge base through to in-house manufacture, Micromeritics delivers an extensive range of high-performance products for academic research and industrial problem-solving.

Under its premium brand Particulate Systems, Micromeritics discovers and commercializes unique and innovative material characterization technologies that are complementary to core product lines.

The company's holistic, customer-centric approach also extends to a cost-efficient contract testing laboratory – the Particle Testing Authority (PTA). The strategic acquisitions of Freeman Technology Ltd and Process Integral Development S.L. (PID Eng & Tech) reflect an ongoing commitment to optimized, integrated solutions in the industrially vital areas of powders and catalysis.

Freeman Technology (Tewkesbury, UK) brings market-leading powder characterization technology to Micromeritics' existing portfolio of particle characterization techniques. The result is a suite of products that directly supports efforts to understand and engineer particle properties to meet powder performance targets. With over 15 years of experience in powder testing, Freeman Technology specializes in systems for measuring the flow properties of powders. In combination with detailed application know-how these systems deliver unrivalled insight into powder behavior supporting development, formulation, scale-up, processing and manufacture across a wide range of industrial sectors.

PID Eng & Tech (Madrid, Spain) complements Micromeritics' renowned offering for catalyst characterization with technology for the measurement and optimization of catalytic activity, with a product range that extends to both standard and bespoke pilot scale equipment. Launched in 2003, PID Eng & Tech is a leading provider of automated, modular microreactor systems for the detailed investigation of reaction kinetics and yield. These products are supported by a highly skilled multidisciplinary team of engineers with in-depth expertise in the design, construction and operation of laboratory units and process scale-up.

The Particle Testing Authority (PTA) provides material characterization services for fine powders and solid materials using Micromeritics' instrumentation alongside complementary solutions from other vendors. With the certification and expertise to operate across a wide range of industries the PTA offering runs from single sample analysis to complex method development, method validation, new product assessment, and the analytical support required for large scale manufacturing projects. An experienced, highly trained team of scientists, engineers, and lab technicians works closely with every client to ensure that all analytical requirements are rapidly and responsively addressed.

Micromeritics has a strong global network with offices across the Americas, Asia, and Europe complemented by a dedicated team of distributors in additional locations. This ensures that local, knowledgeable support is available for every customer, in academia or industry. Micromeritics works across a truly diverse range of industries from oil processing, petrochemicals and catalysts, to food and pharmaceuticals, and at the forefront of characterization technology for next generation materials such as graphene, metal-organic-frameworks, nanocatalysts, and zeolites. Engineering solutions that work optimally for every user is a defining characteristic of the company.

CONTACT US

Micromeritics Instrument Corporation

4356 Communications Drive
Norcross, GA / USA / 30093-2901
Phone: 1-770-662-3636
Fax: 1-770-662-3696
www.Micromeritics.com

Instrument Service or Repair

Phone: 1-770-662-3666
International — contact your local distributor or call 1-770-662-3666
Service.Helpdesk@Micromeritics.com

Micromeritics Learning Center

Phone: 1-770-662-3607
www.Micro.edu

GEMINI 2390A TO GEMINI 2390P UPGRADE INSTRUCTIONS

The Gemini VII 2390a and 2390p are enclosed in the same size cabinet. The only physical difference is the P₀ tube which is installed on the Gemini 2390p, allowing continuous measurement of the saturation pressure. The Gemini 2390p also generates the adsorption isotherm for BJH pore volume distribution.

Required Upgrade kit [part number 239-33603-00]

Part Number	Description
239-25825-00	P ₀ tube
003-55635-02	P ₀ tube transducer
003-22648-00	Valve 24V DC
004-25138-03	Compression fitting, 1/8 in. tube
004-25940-00	Ferrule, 1/8 in. PEEK
004-25468-01	O-ring, Buna-N, -007



Verify kit contents before proceeding.

REQUIRED TOOLS (NOT INCLUDED IN KIT):

- #2 Phillips head screwdriver
 - Valve wrench
 - 5/16 in. Open-end wrench
 - 3/8 in. Open-end wrench
 - 5/8 in. Open-end wrench
1. Power off the Gemini VII 2390 analyzer. The power switch is located on the lower rear panel of the analyzer.
 2. Unplug the instrument power cord from the power source.
 3. Remove the top panel from the analyzer.
 4. Use a 5/16 in. open-end wrench to remove the threaded plug from the end of the sample manifold.

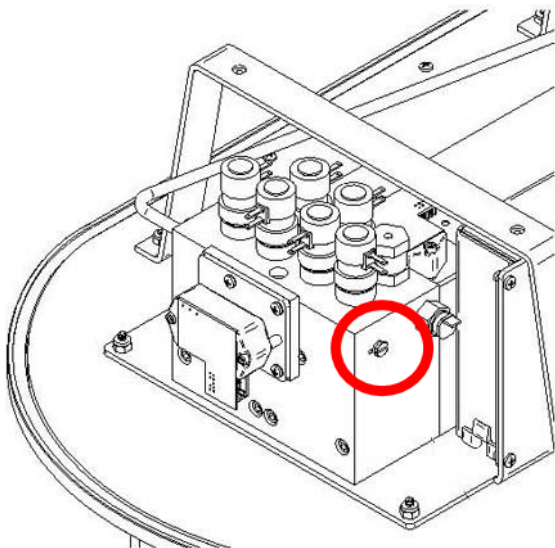

5. Place the O-ring in the P₀ port on the sample manifold, then install the transducer. Tighten with a 5/8 in. open-end wrench.

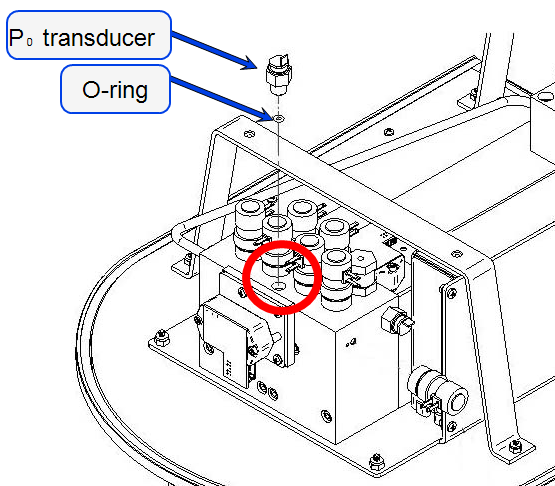

6. Install the P₀ valve in the port where the threaded plug was removed (step 4). Tighten with the valve wrench.

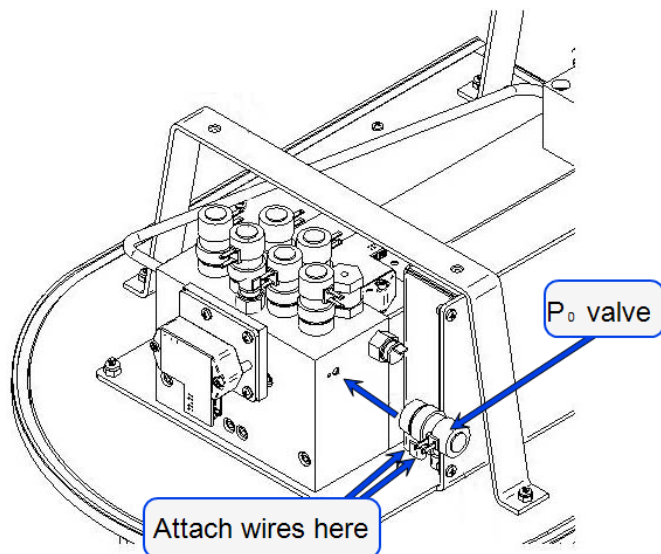

7. Attach the two wires labeled **6** (on the manifold valves cable) to the P₀ valve.
8. Remove the connector nut from the compression fitting body. Discard the two stainless-steel ferrules located inside the fitting.
9. Insert the body of the compression fitting through the P₀ port and connect it to the bottom of the sample manifold. Tighten with a 5/16 in. open-end wrench.

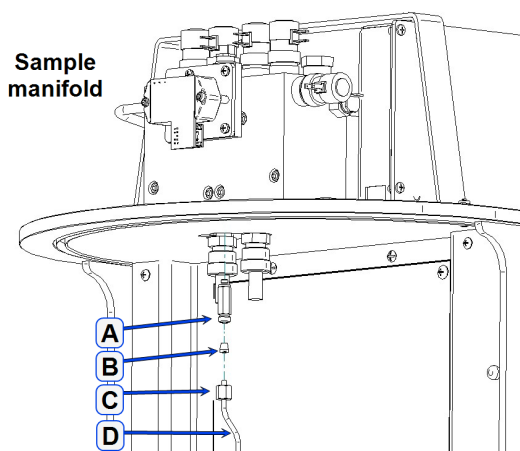

- A. Fitting body
- B. Ferrule
- C. Connector nut
- D. P₀ tube

10. Place the connector nut on the angled side of the P₀ tube, followed by the 1/8 in. PEEK ferrule.
11. Attach the connector nut to the compression fitting body. Tighten with a 3/8 in. open-end wrench.

12. Remove the four screws that attach the grommet plate to the analysis module PCB shield. Slide the plate along the sample transducer cable (attached to the grommet on the right side) to access the grommet for the P₀ cable.

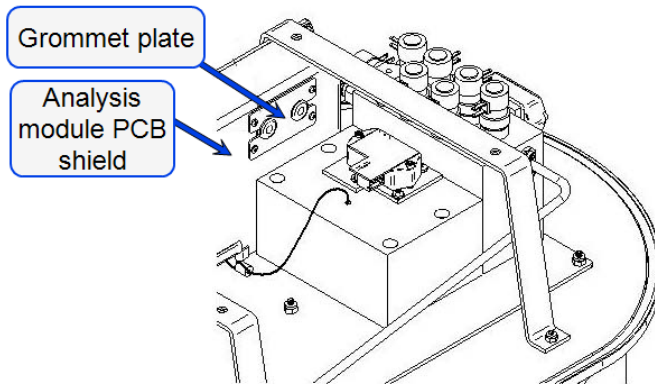

13. Route the cable from the P₀ transducer through the grommet. Connect the cable to the appropriate connector on the analysis module PCB.
14. Slide the grommet plate back into position. Tighten the screws.
15. Replace the analyzer top panel.
16. Plug the power cord into the power source and power on the analyzer. The analyzer will automatically detect the addition of the P₀ tube.

VERIFY THE UPGRADE

TO VERIFY USING A KEYPAD

The *Reload* prompt should display a *p* in the upper right side of the keypad window.

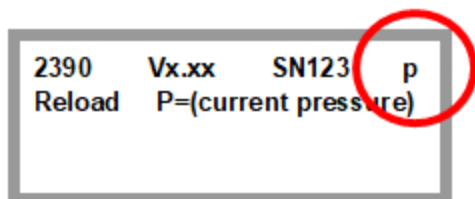

TO VERIFY USING WINDOWS

1. Start the application.
2. Go to **Unit [n] > Instrument Schematic**. The instrument schematic should display the addition indicated below.

