

GEOPYC[®] 1365

ENVELOPE DENSITY ANALYZER



OPERATOR MANUAL

136-42800-01
Apr 2023
(Rev C)

TRADEMARKS

Dry Flo is a trademark of Micromeritics Instrument Corporation.

GeoPyc is a registered trademark of Micromeritics Instrument Corporation.

Micromeritics is a registered trademark of Micromeritics Instrument Corporation.

T.A.P. is a trademark of Micromeritics Instrument Corporation.

Teflon is a registered trademark of E. I. DuPont de Nemours Company.

Copyright

The software described in this manual is furnished under a license agreement and may be used or copied only in accordance with the terms of the agreement.

WARRANTY

MICROMERITICS INSTRUMENT CORPORATION warrants for one year from the date of shipment each instrument it manufactures to be free from defects in material and workmanship impairing its usefulness under normal use and service conditions except as noted herein.

Our liability under this warranty is limited to repair, servicing and adjustment, free of charge at our plant, of any instrument or defective parts when returned prepaid to us and which our examination discloses to have been defective. The purchaser is responsible for all transportation charges involving the shipment of materials for warranty repairs. Failure of any instrument or product due to operator error, improper installation, unauthorized repair or alteration, failure of utilities, or environmental contamination will not constitute a warranty claim. The materials of construction used in MICROMERITICS instruments and other products were chosen after extensive testing and experience for their reliability and durability. However, these materials cannot be totally guaranteed against wear and/or decomposition by chemical action (corrosion) as a result of normal use.

Repair parts are warranted to be free from defects in material and workmanship for 90 days from the date of shipment.

No instrument or product shall be returned to MICROMERITICS prior to notification of alleged defect and authorization to return the instrument or product. All repairs or replacements are made subject to factory inspection of returned parts.

MICROMERITICS shall be released from all obligations under its warranty in the event repairs or modifications are made by persons other than its own authorized service personnel unless such work is authorized in writing by MICROMERITICS.

The obligations of this warranty will be limited under the following conditions:

1. Certain products sold by MICROMERITICS are the products of reputable manufacturers, sold under their respective brand names or trade names. We, therefore, make no express or implied warranty as to such products. We shall use our best efforts to obtain from the manufacturer, in accordance with his customary practice, the repair or replacement of such of his products that may prove defective in workmanship or materials. Service charges made by such manufacturer are the responsibility of the ultimate purchaser. This states our entire liability in respect to such products, except as an authorized person of MICROMERITICS may otherwise agree to in writing.
2. If an instrument or product is found defective during the warranty period, replacement parts may, at the discretion of MICROMERITICS, be sent to be installed by the purchaser, e.g., printed circuit boards, check valves, seals, etc.
3. Expendable items, e.g., sample tubes, detector source lamps, indicator lamps, fuses, valve plugs (rotor) and stems, seals and O-rings, ferrules, etc., are excluded from this warranty except for manufacturing defects. Such items which perform satisfactorily during the first 45 days after the date of shipment are assumed to be free of manufacturing defects.

Purchaser agrees to hold MICROMERITICS harmless from any patent infringement action brought against MICROMERITICS if, at the request of the purchaser, MICROMERITICS modifies a standard product or manufactures a special product to the purchaser's specifications.

MICROMERITICS shall not be liable for consequential or other type damages resulting from the use of any of its products other than the liability stated above. This warranty is in lieu of all other warranties, express or implied, including but not limited to, the implied warranties of merchantability or fitness for use.

CORPORATE PROFILE

Micromeritics Instrument Corporation is the world's leading supplier of high-performance systems to characterize particles, powders and porous materials with a focus on physical properties, chemical activity, and flow properties. Our technology portfolio includes: pycnometry, adsorption, dynamic chemisorption, particle size, intrusion porosimetry, powder rheology, and activity testing of catalysts. The company has R&D and manufacturing sites in the USA, UK, and Spain, and direct sales and service operations throughout the Americas, Europe, and Asia. Micromeritics systems are the instruments-of-choice in more than 10,000 laboratories of the world's most innovative companies and prestigious government and academic institutions. Our world-class scientists and responsive support teams enable customer success by applying Micromeritics technology to the most demanding applications. For more information, please visit www.Micromeritics.com.

CONTACT US

Micromeritics Instrument Corporation

4356 Communications Drive
Norcross, GA / USA / 30093-2901
Phone: 1-770-662-3636
Fax: 1-770-662-3696
www.Micromeritics.com

Instrument Service or Repair

Phone: 1-770-662-3666
International: Contact your local distributor or call 1-770-662-3666
Service.Helpdesk@Micromeritics.com

Micromeritics Application Support

Support@Micromeritics.com

ABOUT THIS MANUAL

The following can be found on the Micromeritics web page (www.Micromeritics.com).

- Calculations document (PDF)
- Error Messages document (PDF)
- Operator Manual (PDF)
- Parts and Accessories



All references to GeoPyc or GeoPyc 1365 in this document encompass the GeoPyc 1365 and GeoPyc 1365 T.A.P. unless otherwise noted.

The following symbols or icons indicate safety precautions and/or supplemental information and may appear in this manual:



NOTE — Notes contain important information applicable to the topic.



CAUTION — Cautions contain information to help prevent actions that may damage the analyzer or components.



WARNING — Warnings contain information to help prevent actions that may cause personal injury.



T.A.P. FEATURE ONLY - Indicates the feature is applicable only when using the Transverse Axial Pressure (T.A.P.) upgrade option.

GENERAL SAFETY



Do not modify this instrument without the authorization of Micromeritics Service Personnel.

Any piece of laboratory equipment can become dangerous to personnel when improperly operated or poorly maintained. All employees operating and maintaining Micromeritics instruments should be familiar with its operation and should be thoroughly trained and instructed on safety.

- Read the operator manual for any special operational instructions for the instrument.
- Know how the instrument functions and understand the operating processes.



- Wear the appropriate personal protective equipment when operating this instrument — such as eye protection, lab coat, protective gloves, etc.
- When lifting or relocating the instrument, use proper lifting and transporting devices for heavy instruments. Ensure that sufficient personnel are available to assist in moving the instrument. The GeoPyc 1365 weighs approximately 19 kg (42 lbs).
- Always pay attention to the safety instructions provided on each label affixed to the instrument and do not alter or remove the labels. When inspecting the instrument, ensure that the safety labels have not become worn or damaged.
- Proper maintenance is critical to personnel safety and smooth instrument operation and performance. Instruments require regular maintenance to help promote safety, provide an optimum end test result, and to prevent costly down time. Failure to practice proper maintenance procedures can lead to unsafe conditions and shorten the life of the instrument.
- Improper handling, disposing of, or transporting potentially hazardous materials can cause serious bodily harm or damage to the instrument. Always refer to the MSDS when handling hazardous materials. Safe operation and handling of the instrument, supplies, and accessories is the responsibility of the operator.

REMOVAL FOR REPAIR OR DISPOSAL OF EQUIPMENT

By following these instructions, you can help ensure that equipment is safely removed from service for repair or disposal and that safety is not compromised when new equipment is put into service.

- Before removing equipment from use for repair or disposal, ensure that all power sources are disconnected and all stored energy sources have been discharged to prevent accidental injury to personnel. Remove all glassware and attachments. Plug any open ports. Shut off and disconnect gas supplies, vacuum pumps, and vents.
- Only qualified personnel should perform repairs or dispose of the equipment. This ensures that the work is done safely and that the equipment is properly disposed of according to local regulations.
- When removing equipment for repair, clearly label it with the reason for removal and the date it was taken out of service. This helps ensure that the equipment is not put back into service until it has been properly repaired and tested.
- When disposing of equipment, follow local regulations for hazardous waste disposal. This may involve recycling, special disposal methods, or other requirements.
- Keep records of all equipment removed from service, including the reason for removal and any repair or disposal actions taken. This helps ensure that the equipment is properly tracked and that safety issues are addressed in a timely manner.
- Ensure that all replacement equipment meets the same safety standards as the equipment being replaced. This helps ensure that safety is not compromised when new equipment is put into service.
- Before returning equipment to service, ensure that it has been properly repaired and tested to ensure that it meets all safety requirements. Only qualified personnel should perform this work.

INTENDED USE

The **GeoPyc** automatically determines the volume and density of a solid object by displacement of DryFlo, a solid medium. The medium consist of a narrow distribution of small, rigid spheres that have a high degree of flow ability and achieve close packing around the object under investigation. The particles are sufficiently small that during consolidation they conform closely to the surface of the object, yet do not invade pore space.



The instrument is intended to be operated by trained personnel familiar with the proper operation of the equipment recommended by the manufacturer and as well as relevant hazards involved and prevention methods. Other than what is described in this manual, all use is seen as unintended use and can cause a safety hazard.



The instrument is intended to be used as per applicable local and national regulations.

TRAINING

It is the customer's responsibility to ensure that all personnel operating or maintaining the equipment participate in training and instruction sessions. All personnel operating, inspecting, servicing, or cleaning this instrument must be properly trained in operation and machine safety before operating this instrument.

ENVIRONMENTALLY FRIENDLY USE PERIOD

Hazardous Substances Table

Part Name	Hazardous Substances					
	Lead (Pb)	Mercury (Hg)	Cadmium (Cd)	Hexavalent Chromium (Cr (VI))	Polybrominated biphenyls (PBB)	Polybrominated diphenyl ethers (PBDE)
Cabinet	x	0	0	0	0	0
Power Supplies	o	o	o	o	o	o
Printed Circuit Boards	x	o	o	o	o	o
TouchPanel & SBC	x	o	o	o	o	o
Connectors	x	o	o	o	o	o
Transducers	x	o	o	o	o	o

- o Hazardous substance is below the specified limits as described in SJ/T11363-2006.
- x Hazardous substance is above the specified limits as described in SJ/T11363-2006.

The Environmentally Friendly Use Period (EFUP) for all enclosed products and their parts are per the symbol shown here unless otherwise marked. Certain parts may have a different EFUP (for example, battery modules) and are marked to reflect such. The Environmentally Friendly Use Period is valid only when the product is operated under the conditions defined in the product manual.



SYMBOLS THAT MAY APPEAR ON THE INSTRUMENT

The following symbols or icons indicate safety precautions and/or supplemental information and may appear on your instrument:



Use extreme caution when working on the instrument where one of these symbols may be displayed. These symbols indicate the part may be hot and cause serious burns.



Use the cotton gloves provided in the accessory when handling heated surfaces. These cotton gloves are not intended to protect hands when heated surfaces are above 60 °C.



When working on the instrument where this symbol is displayed, refer to your Micromeritics' instruction manual for additional information.



When this symbol is displayed, toxic or flammable gases require proper venting of exhaust.

This symbol can also indicate the instrument uses mercury which is an extremely toxic substance. Read the Material Safety Data Sheet (MSDS) and be aware of the hazards of mercury and know what to do in the event of a spill or an exposure incident

**This page
intentionally
left blank**

Table of Contents

About this Manual	iv
General Safety	v
Removal for Repair or Disposal of Equipment	vi
1 About the GeoPyc 1365	1 - 1
T.A.P. Density Upgrade Option	1 - 3
Safety Precautions	1 - 4
Tips for Successful Operation	1 - 5
Remote Browsers	1 - 5
Instrument Status	1 - 6
Specifications for the GeoPyc 1365	1 - 7
2 GeoPyc	2 - 1
Volume Calibration	2 - 4
Select a Calibration Object	2 - 4
Perform a Volume Calibration Run	2 - 5
Blank Data	2 - 6
Perform a Stored Blank Data Run	2 - 6
How Stored Blank Data are Used	2 - 7
Sample Run	2 - 8
Verify Operation	2 - 10
3 Records	3 - 1
Print or Export Records	3 - 3
Reports	3 - 5
Bulk Reports	3 - 5
Bulk Blank Data Set Listing	3 - 6
Bulk Blank Report	3 - 7
Bulk Density Report	3 - 8
Envelope Density Report	3 - 10
Force Calibration Report	3 - 12

Instrument Log Report	3 - 14
Volume Calibration Report	3 - 15
Zero Depth Listing Report	3 - 17
4 SOP (Standard Operating Procedures)	4 - 1
Add a New Procedure	4 - 2
Consolidation Cycles	4 - 4
Consolidation Force	4 - 5
5 Instrument	5 - 1
Chamber and Plunger	5 - 3
Handling the Chamber and Plunger	5 - 3
Remove Chamber and Plunger	5 - 4
Insert Plunger	5 - 4
Mount the Chamber and Plunger	5 - 5
Chamber Diameter	5 - 6
6 Maintenance	6 - 1
Analytical Balance	6 - 4
Remote Computer Configuration	6 - 6
Plunger Assembly Maintenance	6 - 7
Plunger Assembly	6 - 7
Check Plunger Seal	6 - 7
Replace Plunger Piston	6 - 8
Power Instrument On and Off	6 - 9
Printer Installation	6 - 11
Refresh the Browser	6 - 14
Clean the Instrument	6 - 14
Troubleshooting and Maintenance	6 - 14
A Conversion Factor	A - 1
B Displacement Volume	B - 1

C Dry Flo	C - 1
How to Handle Dry Flo	C - 2
Amount of Dry Flo to Use	C - 3
Weigh Dry Flo	C - 5
Dry Flo Bed	C - 6
D Envelope Density	D - 1
E Measurement Method	E - 1
F Zero Depth of a Sample Chamber	F - 1
The Percent Sample Volume	F - 1
Piston Coupling Extenders	F - 2
G T.A.P. Density	G - 1
GeoPyc 1365 EU Declaration of Conformity	DoC - 1
GeoPyc 1365 UK Declaration of Conformity	DoC - 2

**This page
intentionally
left blank**

1 ABOUT THE GEOPYC 1365

FRONT PANEL

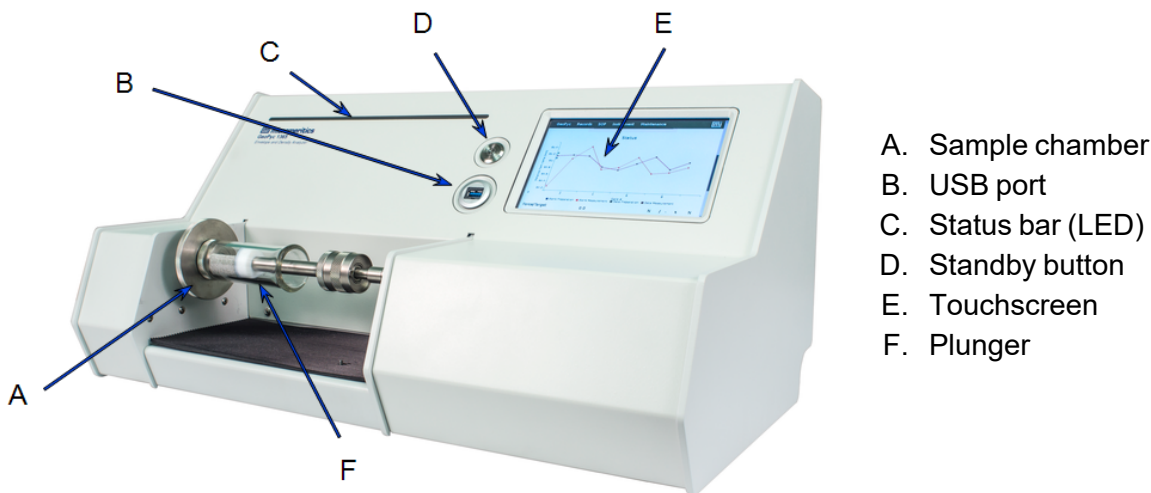

- A. Sample chamber
- B. USB port
- C. Status bar (LED)
- D. Standby button
- E. Touchscreen
- F. Plunger

Front Panel Components

Component	Description
Status bar (LED)	Indicates the analyzer status. See Instrument Status on page 1 - 6 .
Plunger	Compresses the sample and Dry Flo.
Sample chamber	Contains the sample and Dry Flo.
Standby button	Press to turn the screen on or off.
Touchscreen	Use to enter information, monitor analyses, and review results.
USB Port	The USB ports on the front and back of the instrument can be used interchangeably, however, to prevent wires from interfering with the operation of the instrument, use the USB port on the back for devices with cords. The USB ports can be used to connect a printer or keyboard, export and import data, and update software.

REAR PANEL

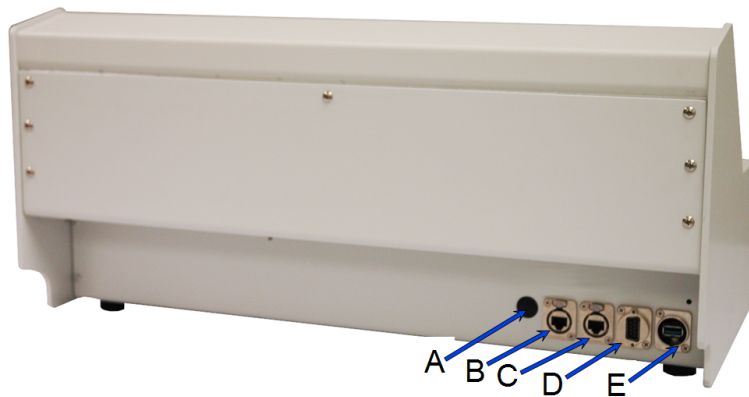

- A. Power connector
- B. Ethernet port (not currently used)
- C. Ethernet port (for computer or network connection)
- D. RS-232 port
- E. USB port

Rear Panel Components

Component	Description
Ethernet ports (2)	The port labeled Network (labeled D in the image) is used to connect the analyzer to a network or directly to a computer. The other (labeled E in the image) is not currently used.
Power	For connecting the analyzer to the power supply adapter with a barrel plug.
RS-232	A mass balance can be connected to the analyzer through the 9 pin RS-232 port. A suitable balance and cable are available through Micromeritics. Data is transmitted through the USB port.
USB ports	The USB ports on the front and back of the instrument can be used interchangeably, however, to prevent wires from interfering with the operation of the instrument, use the USB port on the back for devices with cords. The USB ports can be used to connect a printer or keyboard, export and import data, and update software.

T.A.P. DENSITY UPGRADE OPTION

T.A.P. Density on page G - 1

T.A.P. (Transverse Axial Pressure) density is an optional software upgrade. This upgrade provides a quantifiable, repeatable degree of pressure applied to the sample along its transverse axis.

A common method of measuring bulk density involves placing the sample in a graduated cylinder and then placing the cylinder in an apparatus that physically taps the cylinder causing the material to settle. The mass divided by the resulting volume is known as the “tap” or “tapped” density of the material.

The GeoPyc 1365 T.A.P. software was produced for measurement of bulk density with a standard GeoPyc instrument. Settling of bulk materials is achieved by chamber agitation and piston pressure. The T.A.P. designation is meant to indicate applicability in cases where a tapped analysis might be done, without claiming to do an actual tapped analysis.

The major differences between the standard GeoPyc 1365 application and the GeoPyc 1365 T.A.P. application are:

- An option is provided for using consolidation pressure instead of consolidation force.
- Density values are reported as bulk density rather than envelope density.
- Volume calibration and zero depth analyses are not available.
- Calculations that depend on absolute density are not done.

GEOPYC 1365 T.A.P. APPLICATION INSTALLATION

Installation is performed by inserting a USB device containing the upgrade application into the analyzer USB port. Installation begins automatically. When the upgrade is complete, a banner displays indicating *GeoPyc T.A.P. features are enabled*.

No hardware modifications are required.

SAFETY PRECAUTIONS

SAMPLES

The instrument was designed for nonhazardous samples only.



Do not attempt to use the instrument to analyze any sample material whose safety has not been verified. During normal operation, fine particles may become airborne or skin contact may occur with the sample.

POWER SUPPLY



Use of a power cord or power supply not provided with the instrument could cause personal injury or damage to the equipment. If a replacement is needed, contact your Micromeritics Service Representative. Detachable power supply cords with an inadequate rating could cause significant instrument damage or physical harm.

Do not add anything between the power cord and the power source that would compromise the earth ground.

Do not remove or disable the grounding prong on the instrument power cord.

TIPS FOR SUCCESSFUL OPERATION

- Performing a calibration run using objects similar to the sample size and shape calibrates the conversion factor used during analysis. A calibrated conversion factor yields more accurate results than the calculated conversion factor.
- The closer the calibration object simulates the sample size, shape, and quantity, the better the calibration will be. Calibration with a reference standard works best.
- Performing an embedded blank run during each sample run is preferable to using stored blank data.
- Dry Flo bed lengths no longer than the diameter of the chamber are recommended unless sample shape demands otherwise.
- If final bed length must exceed the diameter of the chamber, increase the consolidation force. An increase in force proportional to the increase in bed length is recommended.
- A single-object sample should be run in the smallest chamber in which it will fit, allowing for consolidated Dry Flo on all sides.
- Large sample quantities (of multi-piece samples) are more representative than small quantities, therefore analyzing a larger quantity of sample in a large chamber may yield more accurate results than analyzing a small quantity of sample in a small chamber.
- The sample must constitute at least 25% of the final bed volume. The analyzer will calculate the percent of sample volume automatically when:
 - *Calculate percent sample volume* is enabled in the SOP.
 - Using a zero depth set from a zero depth run that was performed using the same sample chamber to be used for the sample run.

REMOTE BROWSERS

[Remote Computer Configuration on page 6 - 6](#)

Remote browser sessions can be used to perform the same functions as the touchscreen on the instrument.

INSTRUMENT STATUS

Analyzer Status

File Status	Description
Analyzing	An analysis is currently running.
Ready	Sample files used in an analysis that is completed.
Standby	The touchscreen is disabled. This status is available only on remote browsers.

Status Bar	Standby Button	Touch-screen	Indicates
OFF	OFF	OFF	No power connected to the analyzer
OFF	Orange	OFF	Power is ON. System is booting.
OFF	Blue	OFF	Analyzer is in standby mode or boot process has completed. Press the Standby button to continue.
Blue	OFF	ON	Analyzer is ready to be used.
Green	OFF	ON	Analysis is in progress or plunger is moving to home position.
Red	OFF	ON	An error has occurred.

SPECIFICATIONS FOR THE GEOPYC 1365

Electrical

Voltage	Input: 100 to 240 VAC, 1.6A Output: 24Vdc, 5A (120W) Overvoltage Category II
Power	180 VA maximum
Frequency	50/60 Hz
External Power Adapter	Phihong PSA120U-240L6
Supply Fluctuation	±10%

Environment

Temperature	10 °C to 35 °C (50 °F to 95 °F), operating 0 °C to 50 °C (32 °F to 122 °F), non-operating
Humidity	20% to 80% relative, non-condensing
Indoor or Outdoor use	Indoor only (not suitable for wet locations) Altitude: 5000 m max (16,405 ft) Pollution degree of the intended environment: 2
Location	Instrument should be located in a dust-free, vibration free environment, away from exposure to direct sunlight and direct air drafts.
Degree of Ingress Protection	IPXO

Exposed Materials

To sample	Glass, graphite, Teflon, stainless steel, aluminum, Buna-N, epoxy, ceramic
-----------	--

Available Sample Chambers

Internal diameter	Approximate usable length (of medium bed and sample, when con-
-------------------	--

Available Sample Chambers (continued)

	solidated)
12.7 mm	19 mm
19.1 mm	28 mm
25.4 mm	38 mm
38.1 mm	50 mm
50.8 mm	60 mm

Reproducibility

When sample volume is at least 25% of sample chamber volume: Typically $\pm 1.1\%$

Physical

Height	27 cm (11 in.)
Width	55 cm (22 in.)
Depth	38 cm (15 in.)
Weight	19 kg (42 lbs)

Sample Parameters

Volume	0.3 to 25 cm ³ with full range of sample chambers
--------	--

Due to continuous improvements, specifications are subject to change without notice.

2 GEOPYC

GeoPyc > [SOP Selection]

Use to perform and monitor analyses and calibrations.

The GeoPyc performs three types of analyses. All analyses are run from the **GeoPyc** menu option. The type of analysis is determined by the SOP field selection. To obtain reproducible analysis results, the runs should be performed in the following sequence:

1. [Volume Calibration on page 2 - 4](#)
2. [Blank Data on page 2 - 6](#)
3. [Sample Run on page 2 - 8](#)

When **START** is tapped, the button changes to **CANCEL**. When **CANCEL** is tapped, the button changes to **START**. Analysis stops after the blank stage of an analysis or calibration with measured blank so the sample can be placed in the chamber.

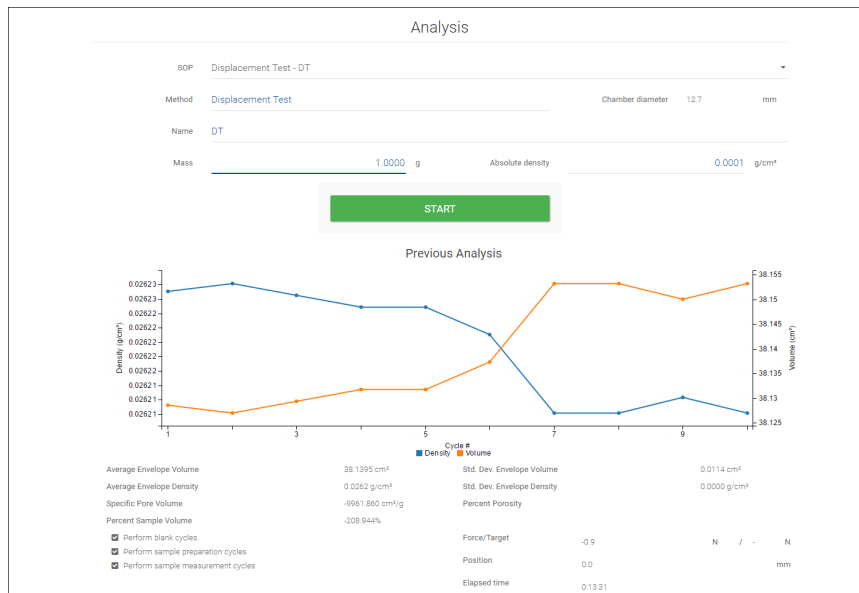

After a blank analysis, the data become part of the blank data set for the selected chamber. After a volume calibration, the new conversion factor is stored in the selected chamber. After a zero depth measurement, the zero depth is stored for the selected chamber.



Only fields and buttons applicable to the selected SOP display.

Analysis Fields

Selections	Description
Absolute Density [text box]	The sample density excluding the volume of pores and cavities. Up and down arrows can also be used to increase or decrease the value. This field does not display when a bulk density SOP is selected. A bulk density selection is available only if using the T.A.P. upgrade option. If the analysis type of <i>Bulk Density</i> is selected with the <i>Run Blank</i> field enabled in the SOP, a field for the consolidation force (pressure) will display.
Cancel [button]	The START button changes to a CANCEL button after an analysis starts. Discards any changes or cancels the current process.
Chamber + medium mass [text box]	Mass of the chamber plus the mass of the medium.
Chamber changed	Message displays when the chamber size differs from the previous analysis.
Chamber diameter [text box]	Internal diameter of the chamber.
ID [text box]	The ID for volume, calibration, volume of the standard, or the mass, density, and porosity must be specified in the SOP.
Mass [text box]	The mass of the sample.
Method [text box]	The method used for the analysis.
Name [text box]	Brief description of the analysis.
Pause [button]	Pauses the analysis.
Resume [button]	Resumes an analysis after the analysis has been paused.
SOP [drop-down box]	Select the SOP to be used to run the analysis. After an SOP is created and saved, it will appear in the SOP drop-down box.
Start [button]	Starts the analysis with the currently selected SOP and parameters. When the chamber for the selected SOP is different from the previous analysis, a <i>Chamber Changed</i> message displays. The START button changes to CANCEL and PAUSE when the analysis starts.

Analysis Fields (continued)

Selections	Description
Status	<ul style="list-style-type: none"> <li data-bbox="565 310 1396 352"> <input type="checkbox"/> Queued cycle <li data-bbox="565 373 860 415"> <input checked="" type="checkbox"/> Completed cycle <li data-bbox="565 436 828 478"> <input type="checkbox"/> Current Cycle <li data-bbox="565 499 1396 573"> <input checked="" type="checkbox"/> Cycle failed to complete or analysis was canceled during a step. <p data-bbox="557 611 1055 642"> Cycle #. Cycle number for the analysis. </p> <p data-bbox="557 646 1396 678"> Elapsed Time. Amount of time elapsed since the analysis started. </p> <p data-bbox="557 682 998 714"> Position. Current plunger position. </p>

VOLUME CALIBRATION

GeoPyc > [insert a Volume Calibration SOP from the drop-down list]

[SOP \(Standard Operating Procedures\) on page 4 - 1](#)

[Maintenance on page 6 - 1](#)

A calibration run is a series of consolidation cycles performed on Dry Flo plus a reference object of known properties that is similar to the sample in size, shape, and quantity. The calibration run calculates a new conversion factor to account for the irregularities of the sample. The result of the calibration is the *Conversion Factor*, which can be entered into an *SOP* or set as a chamber's conversion factor in the *Maintenance* window.

SELECT A CALIBRATION OBJECT

The more closely the calibration object(s) approximates the size and shape of the sample being analyzed, the more accurate the calibration.

Possible calibration objects:

- A reference sample of the sample material.
- A non-porous substitute of similar shape, size, and number as the sample. For example, glass beads may be used as a calibration substitute for pharmaceutical tablets. Glass rod segments could be used as a calibration substitute for extruded catalyst rods.
- A fabricated non-porous model of the sample object, especially objects with deadend holes or through holes.

The presence of large internal cavities or extremes of density reduces accuracy regardless of whether a calibration run is performed. Accurate analysis cannot be performed on extremely small sample pieces (less than 1 to 2 mm in diameter).

PERFORM A VOLUME CALIBRATION RUN

1. Place an appropriate amount of Dry Flo in the sample chamber. Do not place the calibration object in the chamber until prompted.
2. Insert the plunger into the sample chamber and push it part way in. Wipe both ends of the chamber / plunger free of Dry Flo and debris. Mount the chamber / plunger assembly on the analyzer.
3. Create a volume Calibration SOP.
4. Select the SOP from the drop-down list.
5. Tap **START**.
6. The analyzer partially withdraws the plunger.
 - a. Remove the chamber / plunger assembly from the analyzer.
 - b. Carefully remove the plunger.
 - c. Gently tap it on the open chamber so any adhering Dry Flo falls back into the chamber. Any Dry Flo clinging to the chamber's edge can be brushed back into the chamber.
 - d. Set the plunger aside, seal end facing up.
 - e. Slide the calibration object(s) gently down the side of the chamber.



It is assumed in calculations that the amount of Dry Flo in the chamber for this calibration run is exactly the same as for the blank run just performed. It is essential to avoid losing Dry Flo while placing the calibration object in the chamber. If Dry Flo is lost, tap **CANCEL** to cancel the run and begin again.

7. Remount the chamber/plunger assembly on the analyzer.
8. Tap **START** to begin calibration.
9. When the consolidation cycles are finished and the plunger is partially withdrawn, remove the chamber/plunger assembly from the analyzer and recover the calibration object. The new calibrated conversion factor is displayed in the report.

This conversion factor may now be entered into an SOP or set as the default conversion factor for a particular chamber.

BLANK DATA

GeoPyc > [select a Blank Data SOP from the drop-down list]

A blank run is performed on a quantity of Dry Flo then the sample is added and a second measurement is done. The volume of the sample is determined from the difference in plunger positions with and without the sample.

A blank data run may be performed during a sample or calibration run. Blank data can be stored in advance, however, results may be less accurate.



This method requires extremely careful weighing of Dry Flo and sometimes yields less accurate data.

Blank data are stored in sets. A group of stored blank runs using the same consolidation force and number of preparation cycles is called a *Stored Blank Data Set*.

The analyzer can store a blank data set for each chamber. For each set, data from multiple blank runs can be included using graduated quantities of Dry Flo. Each set must contain data for at least two quantities of Dry Flo. The analyzer can then interpolate blank volumes between the data points in the set. The appropriate interpolated blank run data are used when the sample is run.

PERFORM A STORED BLANK DATA RUN

To store blank run data, begin with an amount of Dry Flo slightly smaller than the smallest amount to be used during analysis. Perform the blank run using an SOP with an analysis type of *Blank*. Add a small quantity of Dry Flo, then repeat until the chamber contains slightly more than the largest amount of Dry Flo to be used.

1. Carefully place a quantity of Dry Flo in the sample chamber and weigh it. Accurate weighing is critical. See [Chamber Diameter on page 5 - 6](#).
2. Insert the plunger into the sample chamber and push it part way in.
3. Remount the chamber/plunger assembly on the analyzer.
4. Select a blank SOP and tap **START** to begin the analysis.
5. When the blank analysis is finished, unscrew the plunger from the right mandrel and push the plunger part way into the chamber.
6. Unscrew the sample chamber from the mandrel.
7. Repeat from step 1 with a different amount of Dry Flo.



The *Consolidation Force* must be the same for each blank and for the sample analyses that use those stored blanks. Entering an extremely accurate mass is critical.

HOW STORED BLANK DATA ARE USED

When volumes are calculated for an analysis that uses stored blank data, the chamber+medium mass is compared to the chamber+medium masses of the stored blanks for that chamber. If the mass for the sample analysis falls between two blank masses, the blank plunger position for each cycle in the sample analysis is found by linearly interpolating the corresponding plunger positions from those two blanks.

An error is signaled if:

- The mass for the sample analysis does not fall between two blank masses.
- The two blanks do not have at least as many cycles as the analysis.

SAMPLE RUN

GeoPyc > [select a Sample Run SOP from the drop-down list]

A sample run is a series of consolidation cycles performed on Dry Flo plus the sample. It measures the volume of Dry Flo plus sample. The sample run volume is compared to the blank volume (for the same quantity of Dry Flo) to determine the envelope volume of the sample. Density and porosity data are calculated using this volume and other parameters provided during the sample run.

Sample must be weighed prior to a sample run. Most sample materials increase in weight by adsorbing moisture from the atmosphere. Care should be taken to ensure that the sample mass entered does not include moisture. A drying oven or desiccator may also be used.

The effect of adsorbed moisture on sample volume is negligible. This means efficiency can be increased by drying and weighing a number of samples at once, then setting them aside until it is convenient to determine their envelope density.

During the analysis, a graph of the data taken so far is shown. The x-range is set to the number of requested measurement cycles and does not change. A density vs cycle point is added for each measurement cycle, but not for preparation cycles. A label above the graph indicates *Current Analysis* while the analysis is in progress and *Previous Analysis* upon completion.



For greatest accuracy, perform a calibration run before analyzing samples. See [Volume Calibration on page 2 - 4](#).

1. Weigh the sample.
2. Place an appropriate amount of Dry Flo in the sample chamber filling no more than 3/4s of the sample chamber. Do not place the sample object in the chamber until prompted.
3. Insert the plunger into the sample chamber. Push the plunger part way in. Wipe both ends of the chamber / plunger free of medium and debris. Mount the chamber/plunger assembly on the analyzer.
4. On the touchscreen, tap **GeoPyc**.
5. Enter or select the SOP, ID, and description.
6. Tap **START**.
7. When the blank cycles complete, the analyzer partially withdraws the plunger.
 - a. Unscrew the plunger from the right mandrel.
 - b. Push the plunger part way into the chamber.
 - c. Unscrew the sample chamber from its mandrel.
 - d. Carefully remove the plunger.
 - e. Gently tap the plunger on the open chamber so any adhering Dry Flo falls back into the chamber. Brush any Dry Flo clinging to the flared edge back into the chamber.

- f. Set the plunger aside with the seal end facing up.
- g. Slide the sample object gently down the side of the chamber.

It is assumed in calculations that the amount of Dry Flo in the chamber is exactly the same as for the blank run just performed. It is essential to avoid losing Dry Flo while placing the sample object in the chamber. If Dry Flo is lost, tap **CANCEL** and begin again.

8. Replace the chamber/plunger on the analyzer. Tap **START** to begin the analysis.
9. When the analysis is complete, the plunger partially withdraws from the chamber.
10. Remove the chamber/plunger, then recover the sample. Analysis data are displayed on the touchscreen.

VERIFY OPERATION

When installing an analyzer (or unexpected or unusual analysis results are obtained) the operation of the analyzer should be verified.

1. Perform a calibration run.
2. Perform an analysis without a sample following the instructions for performing a sample run.
 - a. When prompted to place the sample in the chamber, remove the chamber / plunger assembly from the analyzer, but do not remove the plunger.
 - b. Shake the chamber / plunger assembly to eliminate any compaction of the Dry Flo, then replace it on the analyzer.
 - c. The reported envelope volume for the sample should be near zero if the instrument is performing correctly.
3. Perform a sample run using the same object(s) used in the calibration run. During the sample run, use the calibrated conversion factor resulting from the calibration run. The sample run results should be within a percent of the values ascribed to the sample material during the calibration run.



Use this method to check for correct interpolation within stored blank data. Use a quantity of Dry Flo within the range stored in the set. If the resulting volume is not close to zero, the first possible cause to evaluate is the weighing accuracy and repeatability. Unless precise weights are obtained, the stored blank test procedure can give misleading results.

IF ANALYSIS ERRORS OCCUR

1. Ensure the Dry Flo is flowing freely and not contaminated. It is recommended to change to fresh Dry Flo.
2. Evaluate the accuracy of the technique. Ensure Dry Flo is not lost due to splashing or spilling when the sample / calibration object is introduced into the chamber. If using stored blank data, use an extremely accurate method for weighing the Dry Flo. (Masses must be accurate to within a few milligrams.)
3. Evaluate the accuracy of the analytical balance using manufacturer's instructions.
4. Consider whether the chamber / plunger assembly may have become loosened from the analyzer during analysis. If the chamber and plunger to each mandrel are not secure, data may be inaccurate.
5. Calibrate the force transducer. Also check correct interpolation within stored blank data using this method.
6. Ensure sufficient quantity of Dry Flo within the range stored in the set. If the resulting volume is not close to zero, the first possible cause to evaluate is weighing accuracy and repeatability. Unless precise masses are obtained, the stored blank test procedure can give misleading results.





3 RECORDS

Displays a list of all analysis reports from completed analyses.



- Multiple checkboxes can be selected.
- Columns are sortable by tapping the column header.
- The analysis report is displayed by tapping the record.

Records					
<input type="checkbox"/>	Method	Name	Density (g/cm ³)	Std. Dev. (g/cm ³)	Analysis Date
<input type="checkbox"/>	model	Blank run			Jan 23, 2023 11:02 AM
<input type="checkbox"/>	Density	Test	6.5284	0.0663	Jan 23, 2023 11:43 AM
		Envelope Blank Data Set Listing 12.7			Jan 23, 2023 11:02 AM
		Force Calibration			Dec 15, 2022 3:08 PM
		Instrument Log			Jan 23, 2023 11:43 AM
		Zero Depth Data			Dec 15, 2022 3:13 PM

Records

Selections	Description
Density (cm ³ /g)	Average of the cycle densities.
Name	Description of the analysis.
Method	The method name from the SOP.
Analysis Date	The date and time the analysis was run.
Std./dev. (cm ³ /g)	The standard deviation of the cycle densities.
Toolbar	 Deletes the selected record.
	 Opens the Control Chart report for the selected record.
	 Downloads the selected record(s) as a ZIP file (file format is <i>GeoPyc YYYY-MM-DD.zip</i> where <i>YYYY-MM-DD</i> is the download date) to a USB device. If using a remote browser, a directory selector is opened for exporting the selected record(s) in a ZIP file.
	 Select and upload a single record as an XML file or multiple records in a ZIP file. After uploading, a popup window displays the number of records added and the number of records rejected.

Records (continued)

Selections	Description
	 Starts an analysis with this records SOP.
	 Edit this record.



Refer to the [Field Display Summary below](#) table for information on which fields are available for each analysis type. Fields not listed on the table indicate the field is applicable to all analysis types.

Field Display Summary

	Envelope Density	Envelope Blank	Volume Calibration	Bulk Density TAP	Bulk Blank TAP
Sample mass	✓			✓	
Absolute density	✓				
Chamber+medium mass	1	✓			
Preparation cycles	R/O	R/O	R/O	2	R/O
Measurement cycles	R/O	R/O	R/O	R/O	R/O
Consolidation unit	✓	✓	✓	✓	✓
Consolidation force	R/O	R/O	R/O	2	R/O
Conversion factor	✓			✓	
Zero depth	✓		✓		
Chamber diameter	✓	✓	✓	✓	✓

Legend

- R/O Indicates the field displays but cannot be edited in the *Records* view
- 1 Displays if *Run Blank* was not enabled in the SOP
- 2 Displays if *Run Blank* was enabled in the SOP
- ✓ Indicates the field displays

PRINT OR EXPORT RECORDS



The printer must first be attached to the analyzer via a USB port. See [Printer Installation on page 6 - 11](#).



This functionality is only available locally. If performed remotely, the download occurs through the browser.



Verify that the USB device does not contain a *GeoPyc.conf-sample* file. If it does, use a text editor to set the following in the file:

```
InstallApplication = NO  
DownloadApplication = NO
```

If these items are not set, this error message occurs:

Failed to save because USB has been ejected or is absent.

1. Insert the USB device into a USB port on the analyzer.
2. Tap *Records* on the menu.
3. Select one or more records to export.
4. Tap the download icon. A green success message displays upon successful download:

Successfully saved to <USB-location>.zip. Please remove USB.

PRINT FROM A REMOTE COMPUTER:

- Display the record on the computer monitor and press **Ctrl + P** on the keyboard.

USE A PRINTER ATTACHED TO THE ANALYZER:

- Tap the *Records* menu item.
- Select one or more reports to be printed.
- Tap the printer icon. A single report will be generated for all selected reports.

PRINT FROM AN OPEN RECORD:

- Tap the printer icon.

REPORTS

A report is available after analysis if the analyzer is set up to print or transmit data. Analysis reports remain active while an automatic analysis is in progress. The following table describes fields common to most reports. Fields not listed are described in their respective topics.

Reports

Field	Description
Chamber & Medium Mass	Mass of the chamber and medium.
Chamber Diameter	Diameter of the chamber used in the analysis.
Completed	Date and time the analysis was completed.
Conversion factor	Conversion factor used in the analysis.
Instrument	Analyzer used in the analysis.
Operator	Person running the analysis.
Record	Displays the Method and Name entered in the SOP.
Report Time	Date and time the report was requested.
Serial Number	The serial number of the analyzer where the analysis was performed.
Started	Date and time the analysis was started.
Submitter	Person requesting the analysis.
Version	Software version.
Zero Depth	Zero depth of the sample chamber.

BULK REPORTS **TAP**

The GeoPyc uses the calculated distance-to-volume conversion factor for the selected chamber. However, the GeoPyc will use the selected chamber's conversion factor both bulk and envelope blanks. This makes the calculations for bulk density the same as the calculations for envelope density.

BULK BLANK DATA SET LISTING TAP

Bulk Blank Data Set Listing (50.8 mm)								
Instrument GeoPyc			Serial number 110			Version GeoPyc 1365 v2.00 T.A.P.		
Chamber diameter 50.8 mm				Report time Feb 27, 2017 6:39 AM				
Table 1 of 2								
Consolidation pressure (N/cm ²)	0.99	1.23	1.48	1.73	1.97	2.22	2.47	
Consolidation force (N)	20.00	25.00	30.00	35.00	40.00	45.00	50.00	
Preparation cycles	2	2	2	2	2	2	2	
	1	58.8002 mm	58.7899 mm	58.8105 mm	58.8558 mm	58.9343 mm	58.9034 mm	58.9343 mm
	2	58.7184 mm	58.7716 mm	58.8320 mm	58.8581 mm	58.9058 mm	58.9526 mm	58.9709 mm
	3	58.7367 mm	58.7946 mm	58.8613 mm	58.9082 mm	58.8740 mm	58.9058 mm	58.9296 mm
	4	58.7319 mm	58.8343 mm	58.8320 mm	58.8685 mm	58.9367 mm	58.9240 mm	58.9558 mm
	5	58.7208 mm	58.8137 mm	58.8058 mm	58.8478 mm	58.8796 mm	58.9058 mm	58.9740 mm
Table 2 of 2								
Consolidation pressure (N/cm ²)		2.71		2.96		3.21		
Consolidation force (N)		55.00		60.00		65.00		
Preparation cycles		2		2		2		
	1		58.9526 mm		58.9740 mm		59.0209 mm	
	2		58.9740 mm		58.9867 mm		58.9899 mm	
	3		58.9558 mm		58.9740 mm		59.0161 mm	
	4		58.9788 mm		58.9947 mm		59.0240 mm	
	5		58.9923 mm		58.9788 mm		59.0137 mm	

A bulk blank data set is comprised of blank runs with the same chamber diameter but different consolidation forces. If multiple blank runs have the same consolidation force, the most recent one with at least one cycle will be used. The blank data set listing will show a column for each consolidation force.

Stored bulk blank sets will be distinct from stored envelope blanks. There will be separate automatically generated entries in the Records View for bulk and envelope blanks for each chamber. Entries for chambers that have no blank data will not be shown. The blank set entry for a chamber will be removed when the last blank record for that chamber is deleted.

No interpolation is done with bulk blanks; the consolidation force used in an analysis must match that of one of the stored blanks. The counts for the cycles in that data set are subtracted from the corresponding analysis cycles.

Bulk Blank Data Set Listing

Field	Description
Consolidation force	The force with which the chamber contents were compressed.
Consolidation pressure	$P = \frac{4F}{\pi d^2}$ where F is the consolidation force in newtons and d is the chamber diameter in cm.
Preparation cycles	The number of compression cycles performed before the measurement cycles.

BULK BLANK REPORT 

Bulk Blank Report		
Instrument GeoPyc	Serial number 110	Version GeoPyc 1365 v2.00 T.A.P.
Record 38.1 mm Cham Blank - Chamber Blank 38.1 mm 22.5 N		
Operator jch		
Submitter SN110		
Started Feb 23, 2017 3:11 PM	Chamber diameter 38.1 mm	
Completed Feb 23, 2017 3:16 PM	Report time Feb 27, 2017 6:37 AM	
Consolidation force 22.50 N	Preparation cycles 2	
Consolidation pressure 1.97 N/cm ²	Measurement cycles 5	
Cycle #	Displacement (mm)	
1		58.6626
2		58.7240
3		58.6605
4		58.5867
5		58.5549

Bulk Blank Report

Field	Description
Consolidation force	The force with which the chamber contents were compressed.
Consolidation pressure	$P = \frac{4F}{\pi d^2}$ where F is the consolidation force in newtons and d is the chamber diameter in cm.
Measurement cycles	The number of times the plunger builds consolidation force and backs off for each measurement.
Preparation cycles	The number of compression cycles performed before the measurement cycles.

BULK DENSITY REPORT **TAP**

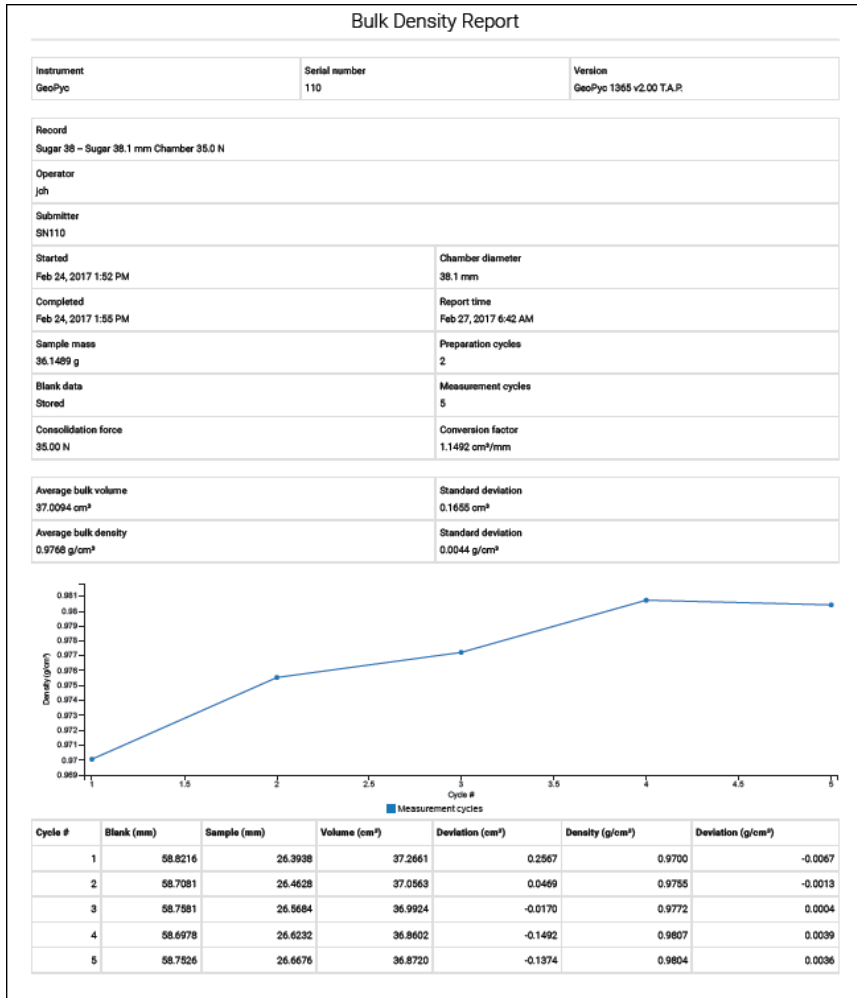

Bulk Density Report

Field	Description
Average bulk density	The average of the Density column in the Measurement Cycle table. Standard deviation. The standard deviation of the densities in the table.
Average bulk volume	The average of the Volume column in the Measurement Cycle table. Standard deviation. The standard deviation of the volumes in the table.

Bulk Density Report (continued)

Field	Description
Blank data	Indicates if the blank data were measured or calculated from stored blanks.
Consolidation force	The force with which the chamber contents were compressed.
Measurement cycles	The number of measurement cycles performed.
Preparation cycles	The number of compression cycles performed before the measurement cycles.

ENVELOPE DENSITY REPORT

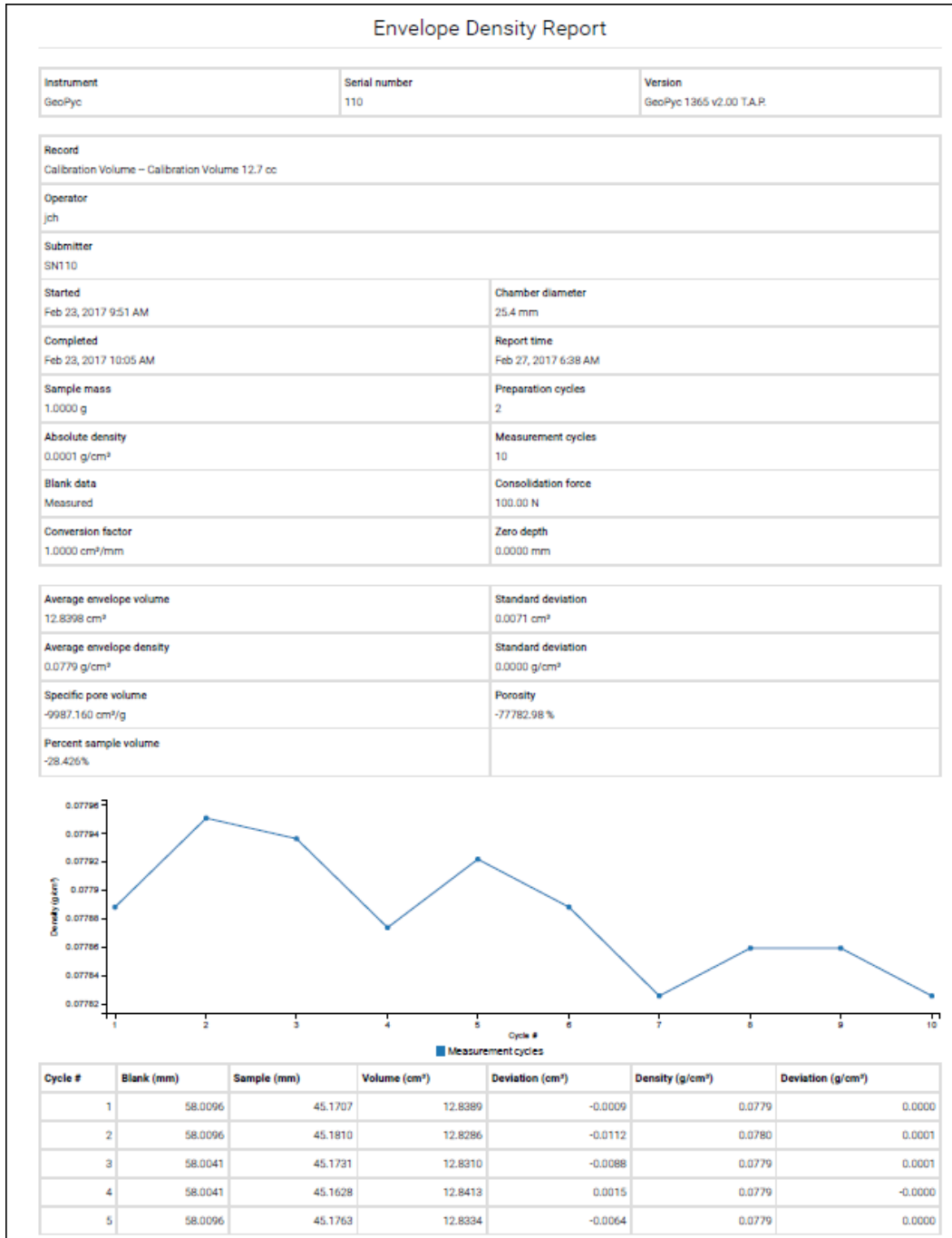

This report lists the counts steps moved by the displacement device during each cycle of a sample run. The report also displays average envelope volume and its standard deviation, and average envelope density and its standard deviation.

The data in this report can be used to make comparisons between samples and comparisons of samples against your standards or specifications. It can also be used to ensure that an adequate amount of sample was contained in the sample bed. To ensure reproducible results, at least 25% of the sample bed should be actual sample.

Envelope Density Report

Field	Description
Absolute density	The sample density excluding the volume of pores and cavities.
Average envelope density	The average of the Density column in the Measurement Cycle table. Standard deviation. The standard deviation of the densities in the table.
Average envelope volume	The average of the Volume column in the Measurement Cycle table. Standard deviation. The standard deviation of the volumes in the table.
Blank data	Indicates if the blank data were measured or calculated from stored blanks.
Consolidation force	The force with which the chamber contents were compressed.
Measurement cycles	The number of measurement cycles performed.
Percent sample volume	The percentage of sample + Dry Flo volume occupied by the sample.
Porosity	The percentage of envelope volume attributed to pores and crevices that are inaccessible to Dry Flo. Requires an entered absolute density.
Preparation cycles	The number of compression cycles performed before the measurement cycles.
Sample mass	The sample mass.
Specific pore volume	Volume of pores per gram of sample. Requires an entered absolute density.

FORCE CALIBRATION REPORT



This report is available after performing a force transducer calibration.

If the report is generated immediately after force calibration, the current number of cycles is equal to the number in the body of the report. If runs were performed after the force calibration but before the report was generated, the current number of cycles is larger than the number in the body of the report.

The transducer is calibrated internally during the calibration process. If the standard deviation and number of counts deviation are within the limits, no action is needed. If analysis data still appear inaccurate or unexpected, causes could be: contaminated Dry Flo, inaccurate weighing, or other methodology problems. If the number of counts deviation is large, or if the standard deviation is greater than 1.0, contact your Micromeritics Service Representative to investigate possible causes.

Force Calibration Report

Cycle	Description
Current displacement cycles	The total number of cycles performed by the analyzer when the report was generated.
Displacement cycles	The total number of cycles performed by the analyzer at the completion of the force calibration.
Points	<p>Calibration readings are taken at 10 points. For each point, the report lists:</p> <p>Displacement. The number of steps of the motor from home position to the point at which force sensor data is recorded.</p> <p>Expected Force (counts). The force exerted by the displacement device at this point, calculated by the instrument from the spring constant and the displacement distance.</p> <p>Force Reading. The uncorrected value from the analog to digital electronics.</p>
Slope	Calculated using the data from the points. These data are used internally by the analyzer to calibrate the force transducer (converts analog force sensor readings into newtons, after removing a zero offset).
Spring constant	Calculated from the formula ($k=F/x$), the spring constant is the force (in newtons) exerted per unit distance (centimeters).
Standard deviation	Calculated using the points and slope data. Standard deviation should be less than 1.0 N.

INSTRUMENT LOG REPORT

Displays recent analyses and calibrations.

Instrument Log Report		
Instrument	GeoPyc	Serial number 000
		Version GeoPyc 1365 v1.00
Report time		Feb 14, 2017 10:06 AM
Time	Type	Description
July 1, 2016, 10:40 a.m.	Calibration	Blank cycle 2/5 finished.
July 1, 2016, 10:38 a.m.	Calibration	Blank cycle 1/5 finished.
July 1, 2016, 10:36 a.m.	Calibration	Starting to record blank cycles.
July 1, 2016, 10:36 a.m.	Calibration	Calibration analysis started.
June 24, 2016, 4:12 p.m.	Calibration	Blank cycle 1/5 finished.
June 24, 2016, 4:10 p.m.	Calibration	Starting to record blank cycles.
June 24, 2016, 4:10 p.m.	Calibration	Calibration analysis started.
June 14, 2016, 1:35 p.m.	Analysis	Tenetur reiciendis ut quo et recusandae voluptates ratione ut at.
June 14, 2016, 1:35 p.m.	ForceCalibration	Est et veritatis corporis quae voluptatibus vel hic saepe aliquam odio odit.

VOLUME CALIBRATION REPORT

Volume Calibration Report					
Instrument	GeoPyc	Serial number	101	version	1.00
Record	Marble_Cal2 -- 25.4 mm Chamber Calibration with 0.656 mm Marble				
Operator	jch				
Submitter	SN101				
Started	Oct 7, 2016 3:56 PM	Chamber diameter	25.4 mm		
Completed	Oct 10, 2016 2:50 PM	Report time	Oct 12, 2016 12:39 PM		
Reference volume	2.3611 cm ³	Preparation cycles	2		
Blank data	Measured	Measurement cycles	10		
Chamber + medium mass	N/A	Consolidation force	51.0 N		
Average envelope volume	2.2947 cm ³	Standard deviation	0.0398 cm ³		

This report lists the counts (steps moved by the displacement device) during each cycle of a calibration run. A calibration run is performed using a calibration object of known properties similar to the sample in size, shape, and quantity. It also reports average envelope volume, standard deviation, and volume error (the adjustment to the volume attributed to the sample's shape, size, etc.).

Use the conversion factor in sample runs for samples similar to the calibration object used in this run. For greater accuracy, perform three calibration runs and average the conversion factors from the three reports. Use the average as the conversion factor in sample runs for this type sample.

Volume Calibration Report

Field	Description
Instrument	Name of the instrument.
Serial Number	Serial number for the instrument.

Volume Calibration Report (continued)

Field	Description
Version	Version number of the software used for data collection.
Record	Record description entered at analysis time.
Operator	Operator identification entered at analysis time.
Submitter	Submitter identification entered at analysis time.
Started	Date and time when the analysis was started.
Completed	Date and time when the analysis finished.
Reference Volume	Volume of the reference object specified in the SOP
Blank Data	"Measured" or "Calculated" depending on the blank method specified in the SOP.
Chamber + medium mass	For calculated blank, the total mass of the chamber and Dry Flo specified in the SOP
Chamber diameter	Diameter of the sample chamber selected in the SOP or edited in the record
Report time	Date and time when the report was produced.
Preparation cycles	Number of preparation cycles specified in the SOP.
Measurement cycles	Number of measurement cycles specified in the SOP.
Consolidation force	Consolidation force specified in the SOP.
Blank counts	The number of steps the motor moved to achieve the consolidation force specified for each blank cycle.
Deviation	The difference between the average envelope volume and the volume measured for this consolidation cycle.
Sample counts	The number of steps the motor moved to achieve the consolidation force for each sample cycle.
Volume	The difference between the blank and sample counts, converted by the analyzer to volume.

ZERO DEPTH LISTING REPORT

Zero Depth Listing					
Instrument	GeoPyc	Serial number	000	Version	GeoPyc 1365 v1.00
Report time		Feb 14, 2017 10:12 AM			
Chamber diameter (mm)		Zero depth (mm)			
12.7		0.0000			
19.1		0.0000			
25.4		0.0000			
38.1		0.0000			
50.8		0.0000			

This report shows the zero depth of up to five sample chambers. The zero depth is used to calculate the percent of sample in the sample bed. This percentage is shown in the *Envelope Density Report*.

**This page
intentionally
left blank**

4 SOP (STANDARD OPERATING PROCEDURES)



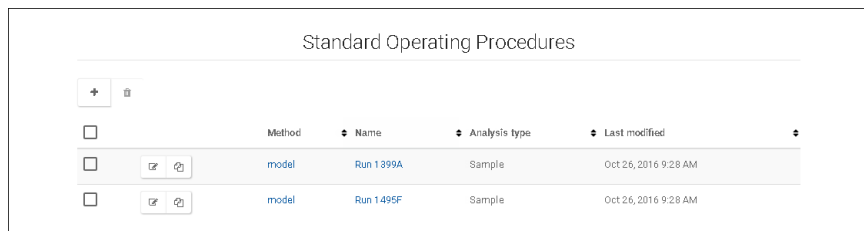







Use to define analysis conditions.



SOP

Selections	Description
Analysis Type	The type of analysis. <ul style="list-style-type: none"> ▪ Bulk blank TAP ▪ Bulk density TAP ▪ Envelope blank ▪ Envelope density ▪ Volume calibration
Last Modified	The date and time the record was last modified.
Method	Method used to run the analysis.
Name	Description of the analysis.
Toolbar	<div style="display: flex; align-items: center; border-bottom: 1px solid black; padding-bottom: 5px;"> Tap to create a new procedure. </div> <div style="display: flex; align-items: center; border-bottom: 1px solid black; padding-bottom: 5px;"> Use to select or deselect record. </div> <div style="display: flex; align-items: center; border-bottom: 1px solid black; padding-bottom: 5px;"> Deletes the selected record from the list. Tap the box to the left of the record to enable it, then tap the Delete icon to delete the record. </div> <div style="display: flex; align-items: center; border-bottom: 1px solid black; padding-bottom: 5px;"> Tap to open and edit the selected record. </div> <div style="display: flex; align-items: center; padding-bottom: 5px;"> Copies the selected record. </div>

ADD A NEW PROCEDURE

 MIC SAS: Ready MIC SAS Records SOP Instrument Maintenance Help				
				
<input type="checkbox"/>		Material	Sample Name	Analysis Type
<input type="checkbox"/>	 	Tungsten	Inorganic	Inorganics
<input type="checkbox"/>	 	Unknown	organic	Organics
<input type="checkbox"/>	 	New SOP	New SOP	Organics
<input type="checkbox"/>	 	New SOP	New SOP	Organics
			Analysis Type	Last Modified
				March 8, 2019, 2:14 p.m.
				Feb. 14, 2019, 10:45 a.m.
				Feb. 13, 2019, 12:17 p.m.
				Feb. 13, 2019, 12:16 p.m.

1. Tap **SOP** on the menu bar.
2. Tap the **Plus** icon.
3. Complete the form using the following table as a guide.
4. Tap **Update** to save the SOP. The SOP will display on the *Standard Operating Procedures* window.



Refer to the *SOP* table for information on which fields are available for each analysis type. Fields not listed on the table indicate the field is applicable to all analysis types.

SOP

Selections	Description
Absolute density [text box]	The sample density excluding the volume of pores and cavities.
Analysis Type [drop-down box]	Select the type of analysis.
Calculate percent sample volume [check box]	Select to have the percent sample volume calculated. See Zero Depth of a Sample Chamber on page F - 1 .
Cancel [button]	Discards any changes or cancels the current process.
Chamber [drop-down box]	Select the chamber size to be used. Entries in this field can be modified in the <i>Maintenance</i> section.
Chamber + medium mass [text box]	Mass of the chamber and medium.

SOP (continued)

Selections	Description
Entered consolidation force [button]	Default. Tap to use the default consolidation force. Enter. Tap to manually enter the new consolidation force.
Entered conversion factor [button]	Default. Tap to use the default conversion factor. Enter. Tap to manually enter the new conversion factor.
Entered zero depth [button]	Default. Tap to use the default zero depth. Enter. Tap to manually enter the new zero depth.
Input reference volume [button]	Enter. Tap to enter the reference volume manually. Calculate. Tap to allow the system to calculate the reference volume. Reference mass. The mass of the calibration objects. Absolute density. The absolute density of the calibration objects. Porosity. The percent porosity of the calibration objects.
Measurement cycle count [text box]	Enter the number of measurement cycles to be run.
Method [text box]	Method used to run the analysis.
Name [text box]	Name of the procedure.
Operator [text box]	Person running the analysis.
Porosity [text box]	Displays when Calculate is selected.
Preparation cycle count [scroll selection]	Enter the number of preparation cycles to be run. It is recommended that at least two preparation cycles and five subsequent cycles be performed on each sample.
Run blank [checkbox]	Select to run an analysis with no sample.
Sample mass [scroll selection]	Enter the sample mass.
Submitter [text box]	Person requesting the analysis.
Update [button]	Saves the entered information and closes the window.

CONSOLIDATION CYCLES

To measure the volume of the chamber contents, it is necessary to consolidate the Dry Flo during an analysis. To do this, the analyzer performs a consolidation cycle. During a consolidation cycle, the analyzer agitates the chamber (by rotational oscillation) while a plunger moves forward into it. When the user-specified consolidation force is reached, the analyzer records the volume, then retracts the plunger slightly.

To gather statistically useful data, the analyzer automatically performs a series of such consolidation cycles during each analysis run. The number of consolidation cycles performed during an analysis run is specified by the operator.

Because of initial settling of the Dry Flo, consolidation is less consistent in the first few cycles than in subsequent cycles. These first cycles are called *Preparation Cycles*. The number of preparation cycles is setup in the SOP. The software automatically discards data from these cycles before making calculations.

Subsequent cycles produce quite consistent results. In order to derive meaningful statistical information, it is recommended that at least two preparation cycles (the default number) and five subsequent cycles be performed on each sample, for a total of seven cycles.

CONSOLIDATION FORCE

Consolidation force is the force with which the chamber contents were compressed. The type of force can be specified during the blank run.



The same force must be used for blank, sample, and calibration runs for a given sample.

Typical Consolidation Force

Internal Chamber Diameter (mm)	Typical Consolidation Force (N)
12.7	28
19.1	38
25.4	51
38.1	90
50.8	145

A different force may be used to decrease the force when analyzing a very soft or fragile sample.

- If too low a force is entered, the plunger may move forward slowly or not at all. (If this occurs, start again using a greater force.)
- Increase the force when performing an analysis with a sample plus Dry Flo bed longer than the diameter of the chamber.
- If the Dry Flo remains compacted into cakes or clumps after analysis, decrease the force.

**This page
intentionally
left blank**



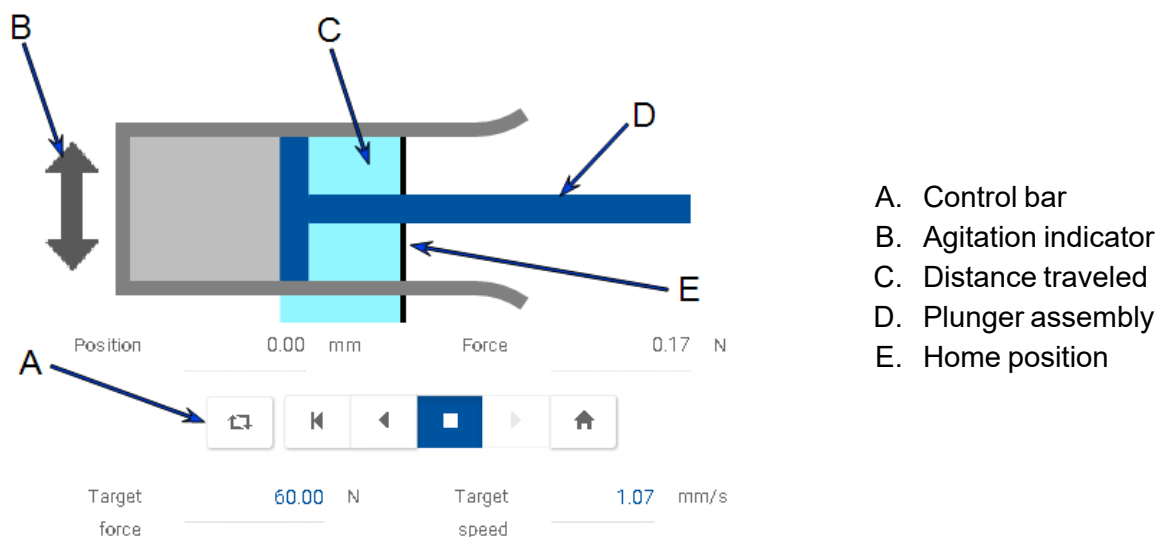

5 INSTRUMENT

The plunger graphic moves as the analyzer plunger moves. Use the control bar to position the plunger manually. A highlighted control bar button indicates the state of the operation. The plunger cannot be controlled from remote browsers.

The control bar and entry fields are disabled when the analyzer status is *Analyzing* or *Standby*, however the control bar buttons will still be highlighted to show the current state of the analyzer.



Manual Control

Selections	Description
Control bar	 Toggle chamber agitation.
	 Move the plunger in. Stop when the target force is achieved.
	 Move the plunger in. This button is disabled when the plunger is at the maximum limit switch.
	 Stop the plunger movement.
	 Move the plunger out. This button is disabled when the plunger is at the minimum limit switch.

Manual Control (continued)

Selections	Description
	 Send the plunger assembly to the Home position.
Force	Plunger force.
Position	Plunger position.
Target Force	Set the target force of the plunger. Changes to this field occur immediately even if the plunger is in motion.
Target Speed	Set the speed of the plunger. Changes to this field occur immediately even if the plunger is in motion.

CHAMBER AND PLUNGER

HANDLING THE CHAMBER AND PLUNGER

When not in use, rest the chamber on the solid end (open end or plunger end facing up) and leave the plunger in the chamber. When the plunger is not in the chamber, stand it on end, seal facing up.

When sliding the plunger out of the chamber, work the end of the plunger slowly and carefully out of the open end of the chamber. Pulling the plunger out of the chamber in a quick, uncontrolled motion may result in Dry Flo being expelled from the chamber.

While removing the plunger from the chamber, tap the seal end lightly on the open end of the chamber. Brush any Dry Flo that adheres to the plunger's seal end or to the flared end of the chamber back into the chamber.



Use caution to not spill or lose any Dry Flo when handling the chamber, plunger, and sample. The volume of lost medium directly reduces the calculated volume of the sample.

Slide the sample gently down the side of the chamber. Never drop a sample into the Dry Flo bed. Dropping the sample into the bed can cause splashing and Dry Flo may spill from the chamber.

Position a single piece sample in the center of the chamber. Shake the assembled chamber and plunger to help position the sample within the Dry Flo. Try to distribute multi-piece samples evenly throughout the chamber. For best results, use sample pieces larger than 1 to 2 mm in length or diameter.

REMOVE CHAMBER AND PLUNGER



Do not attempt to remove the chamber and plunger while the analyzer is operating.



While removing the chamber / plunger assembly from the analyzer, check to see if either end has become loose during analysis. If either end is not securely attached to the mandrel, analysis data may be inaccurate. Ensure that the chamber and plunger are securely attached to the analyzer and restart the analysis.

1. Unscrew the plunger from the right mandrel by turning the coupling on the mandrel toward you. Continue turning / unscrewing until the plunger is free of the mandrel. Hold the plunger to stabilize it while turning the coupling.
2. Push the plunger a small distance into the chamber.
3. Unscrew the chamber from the left mandrel (in the center of the large disc) by turning the chamber toward you. Hold the disc to stabilize it while unscrewing the chamber.
4. When the chamber is free, remove it from the mandrel.

INSERT PLUNGER

The seal end of each plunger fits snugly into the corresponding chamber. The plunger slides slowly but smoothly inside the chamber. After loading the chamber, slide the seal end of the plunger about a third of the way into the chamber.

MOUNT THE CHAMBER AND PLUNGER

1. Ensure the plunger is inserted partially into the loaded chamber.
2. Hold the chamber / plunger between the two mandrels on the instrument, with the chamber end to the left.
3. Screw the chamber onto the threads in the center of the left mandrel. Turn the chamber away from you until it is firmly secured. Hold the mandrel to stabilize it while mounting the chamber.

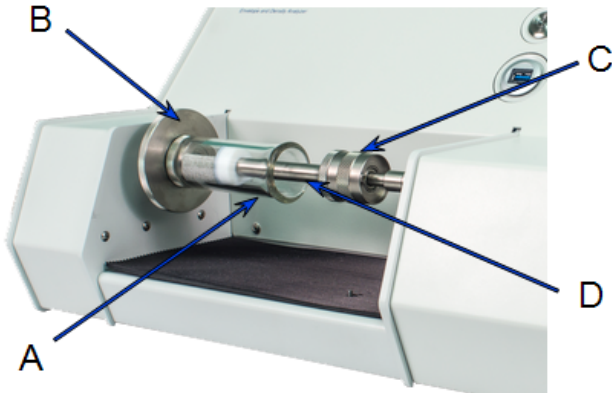

- A. Sample chamber
- B. Left mandrel
- C. Right mandrel
- D. Plunger

4. Extend the plunger part way out of the chamber until the right mandrel is inserted into the hole on the end of the plunger.
5. Turn the coupling on the mandrel away from you to screw the plunger onto the right mandrel. Continue turning / screwing until the plunger is firmly secured. Hold the plunger to stabilize it while turning the coupling.



It is important that the chamber/plunger is secured firmly to each mandrel.

CHAMBER DIAMETER

One analysis chamber (and corresponding plunger) is provided with the analyzer. Several sizes are available to accommodate a variety of sample types and quantities. Parts and accessories are located on the [Micromeritics](#) web page.

For best results, select the chamber where the sample will cause the greatest volumetric change in the medium bed. This also means selecting the smallest chamber in which the sample will fit when surrounded by enough Dry Flo to create a consolidated bed on all sides.

Determine the internal chamber diameter by measuring the plunger seal. The diameter of the seal diameter is the same as the internal diameter of the chamber. (Do not measure the chamber.)

6 MAINTENANCE

Shows information about the analyzer, allows unit selection, and allows editing of the chamber parameters.

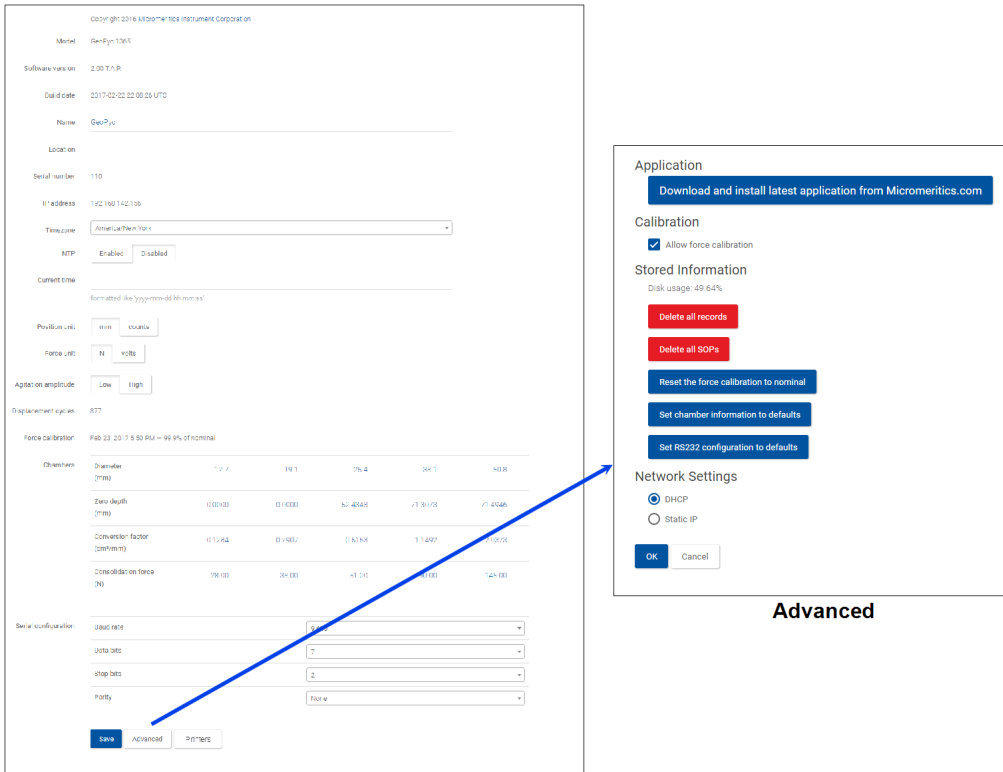

Advanced

Maintenance

Selections	Description
<p>Advanced [button]</p>	<div style="border: 1px solid #ccc; padding: 5px; margin-bottom: 10px;"> <p>These settings affect the operation of the analyzer. Make changes only under the direction of a Micromeritics Service Representative.</p> </div> <hr style="border: 1px solid #ffff00;"/> <p>Administrator-level configuration options. Enabled only when the analyzer is idle.</p> <p>Application. Tap DOWNLOAD AND INSTALL to download and install the latest version of the application. This button does not display on a remote computer nor does it display if the analyzer application is up-to-date.</p> <p>Calibration. Select the <i>Allow force calibration</i> option to allow force calibration.</p>

Maintenance (continued)

Selections	Description
	<p>Stored Information. Displays the disk space used by the application and associated records.</p> <p>Tap the applicable button to delete or reset options:</p> <ul style="list-style-type: none"> ▪ Delete all records ▪ Delete all SOPs ▪ Reset the force calibration to nominal ▪ Set chamber information to defaults ▪ Set RS-232 configuration to defaults <p>Network Settings. Select if the analyzer uses DHCP or a Static IP address.</p>
Agitation Amplitude [button]	Select if the agitation should be set to low or high.
Build date	Displays the software release date.
Chambers	Settings for the chamber's diameter, zero depth, conversion factor, and consolidation force.
Current time [text box]	By default, the application uses UTC (Coordinated Universal Time) to set the current date and time, however if using NTP (Network Time Protocol) enable the NTP option and complete the Current time field (yyyy-mm-dd-hh:mm:ss format). Also select the timezone using the Timezone drop-down box.
Displacement cycles	Total number of cycles performed since the force calibration.
Force Calibration	The calibration slope as a percentage of the nominal slope.
Force Unit [button]	Select if the force should be displayed in newtons or as counts.
IP address	IP address of the instrument.
Location [text box]	Location of the instrument.
Model	Analyzer model.
Name [text box]	The name of the instrument (such as lab number, etc.).

Maintenance (continued)

Selections	Description
NTP [<i>button</i>]	Select to keep the analyzer's clock synchronized with network time servers.
Position Unit [<i>button</i>]	Select if the plunger position should be displayed in mm or counts.
Printer [<i>button</i>]	For use with a printer attached to the GeoPyc. Use to view printer setup, configure a new printer, or view print jobs. See Printer Installation on page 6 - 11
Save [<i>button</i>]	Saves screen changes.
Serial configuration	Use to configure a device attached to the analyzer serial port — such as a balance. See Analytical Balance on the next page .
Serial Number	Serial number of the instrument.
Software Version	Version of the installed software application.
Timezone [<i>drop-down box</i>]	Select the local time zone.

ANALYTICAL BALANCE

An analytical balance is optional. If mass is to be entered into the analysis application manually, the balance does not need to be connected to the instrument .



- For Micromeritics supplied analytical balances, use the appropriate configuration settings for the revision level located on the back of the analytical balance. Settings are provided below.
- For balances not supplied by Micromeritics, refer to the operator manual supplied with the balance.

Go to ***Maintenance > Serial configuration*** to configure the following:

Micromeritics Supplied Balance Configuration Settings

Option	Series E and Earlier	Series F and Later
Baud Rate	9600	9600
Data Bits	7	8
Stop Bits	2	1
Parity	None	None

For Micromeritics supplied analytical balance series E and earlier, the balance must be attached to the instrument using the provided serial cable. Attach one end of the serial cable to the RS-232 port on the back of the instrument and the other end to the balance.

For Micromeritics supplied analytical balance series F and later, the balance must be attached to the instrument using the provided serial cable or the provided USB cable. Attach one end of the cable to the appropriate port on the back of the instrument and the other end to the balance.

To enter mass manually

1. Go to *GeoPyc* on the analyzer application menu.
2. Tap the *Mass* field. Enter the mass using either the virtual keyboard or an attached keyboard.

To send mass from an attached analytical balance:

1. Go to *GeoPyc* on the analyzer application menu.
2. Tap the *Mass* field then press the **Send** button on the balance. The *Mass* field gets updated.



Make sure the balance is configured to send mass in grams.

REMOTE COMPUTER CONFIGURATION

The remote computer and the instrument must be on the same network. The following is the recommended configuration:

- The IP addresses on both devices must have the same first three sets of 0-255 numbers (octets) and differ in their last octets.
- The subnet masks on both devices should be 255.255.255.0.
- The gateways on both devices must be the same, but must differ from the IP addresses in their last octets (optional).

Configuration Settings Examples

	Instrument Setting	Remote Computer
IP Address	192.168.77.101	192.168.77.100
Subnet Mask	255.255.255.0	255.255.255.0
Gateway	192.168.77.10	192.168.77.10



If the remote computer has multiple Network Interface Cards (NICs), only change the settings of the NIC that is connected to the instrument. Refer to the computer's operating system manual or the internet for instructions on how to change the network settings of the NIC in use.

Bridged instruments must have different IP addresses.

1. In the instrument application, tap the *Maintenance* menu, then tap **Advanced**.
2. In the *Network* field, tap *Static* and enter the details from the *GeoPyc 1365* column in the table [Configuration Settings Examples above](#).



If an error occurs regarding IP conflicts, contact your IT department to release IP addresses on the same subnet.

To access the instrument from the remote computer, enter the IP address of the instrument in a web browser on the remote computer. Firefox and Chrome are the recommended browsers.

PLUNGER ASSEMBLY MAINTENANCE

PLUNGER ASSEMBLY

The plunger assembly consists of a Teflon piston attached to a piston rod. The outer rim of the piston is expanded outward with an embedded quad ring.

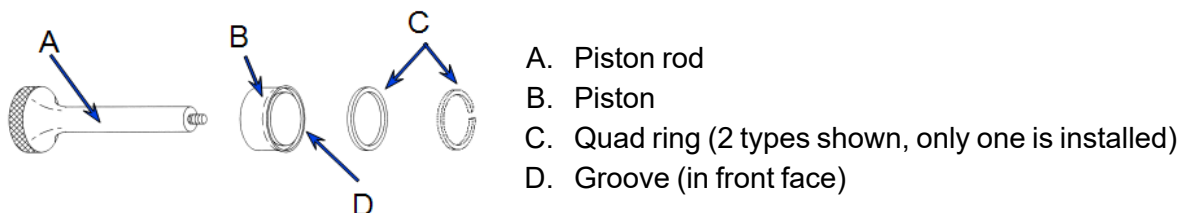

The piston is resistant to wear and provides sealing for prolonged usage if handled and maintained properly. It is recommended to clean the sealing area daily using a wipe moistened with isopropyl alcohol. Ensure the seal is dry before using the plunger again.

CHECK PLUNGER SEAL

When a leakage develops, it is typically caused by the piston having lost some of its expanded condition due to a characteristic of Teflon undergoing cold flow — as opposed to wear. The piston is easily restored to full operation when the cause is not wear.

Wipe or brush the piston free of adhering particles. Use a round-bottom object, such as the handle of the brush supplied with the analyzer, press down on the quad ring, and move the object around the piston circumference, forcing the piston rim outward.

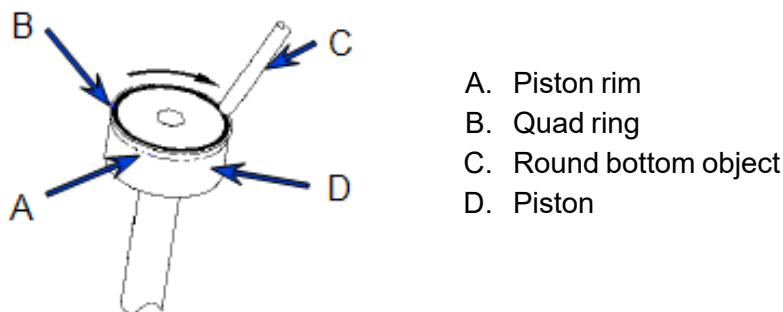

REPLACE PLUNGER PISTON

It is recommended to replace the piston and the quad ring at the same time.

1. Unscrew the piston rod from the piston.
2. The quad ring is preloaded in the groove on the front of the piston. If it has become dislodged, insert the quad ring into the groove on the front face of the piston.
3. Screw the piston rod into the back face.
4. Tighten the plunger assembly firmly without using excessive force.
5. Test the tightness of the piston:
 - a. Place the plunger in an empty chamber.
 - b. Holding the plunger still, rotate the chamber around the plunger in a direction that would tend to unscrew the piston. If the motion of the chamber begins to unscrew the plunger assembly, it needs to be tightened further.

POWER INSTRUMENT ON AND OFF



Do not connect or disconnect cables when the instrument is powered ON.



Do not position the instrument so that it is difficult to operate the disconnecting device.

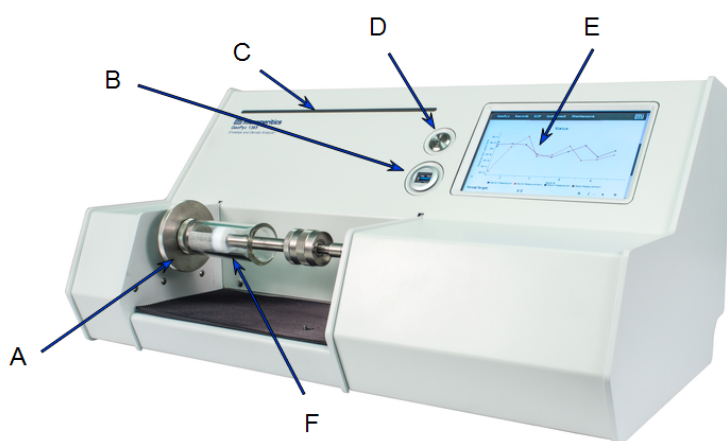

- A. Sample chamber
- B. USB port
- C. Status bar (LED)
- D. Standby button
- E. Touchscreen
- F. Plunger

No warmup is needed unless the analyzer has been moved recently from an area that is much colder or much warmer than the current location. In that case, allow the analyzer to reach room temperature before powering ON.



There is no hard power switch for the analyzer. When the analyzer is plugged in, power is applied to the analyzer.

POWER-ON SEQUENCE

1. Plug in the analyzer. (There is no **ON/OFF** power switch.)
 - The **Standby** button LED illuminates orange while the system is booting up.
 - When the bootup process completes and the analyzer application is running, the **Standby** button LED illuminates blue.
2. When the **Standby** button illuminates blue, press the **Standby** button to activate the touchscreen. The **Standby** button is no longer illuminated.

STANDBY MODE

To activate standby mode, press the **Standby** button. The touchscreen will turn off and the **Standby** button LED illuminates blue.

To exit standby mode, press the (blue) **Standby** button. The status bar LED illuminates blue when exiting standby mode only if the plunger is not at the home position. In this case, it illuminates blue while the plunger is returning to home position. Once the plunger returns to home position, the status bar LED turns green indicating that the analyzer is ready to be used.

PRINTER INSTALLATION

These instructions are for configuring a printer attached to the analyzer. When configuration is complete, use the *Jobs* tab to view queued print jobs.

1. Tap the *Maintenance* tab.
2. Tap **Printers** at the bottom of the window.

Copyright 2016 Micromeritics Instrument Corporation

Model: GeoPyc 1365

Software version: 2.00 T.A.P.

Build date: 2017-02-02 22:08:26 UTC

Name: GeoPyc

Location: _____

Serial number: 110

IP address: 192.168.142.156

Timezone: America/New York

NTP: Enabled Disabled

Current time: _____
formatted like yyyy-mm-dd hh:mm:ss

Position unit: mm counts

Force unit: N volts

Agitation amplitude: Low High

Displacement cycles: 877

Force calibration: Feb 23, 2017 5:50 PM - 99.9% of nominal

Chambers	Diameter (mm)	12.7	19.1	25.4	38.1	50.8
Zero depth (mm)	0.0000	0.0000	52.4343	71.3073	71.4946	
Conversion factor (cm ³ /mm)	0.1284	0.2907	0.5153	1.1492	2.0373	
Consolidation force (N)	28.00	38.00	51.00	90.00	145.00	

Serial configuration

Baud rate: 9600

Data bits: 7

Stop bits: 2

Parity: None

Save Advanced Printers

3. On the *Administration* tab, tap **Add Printer**.

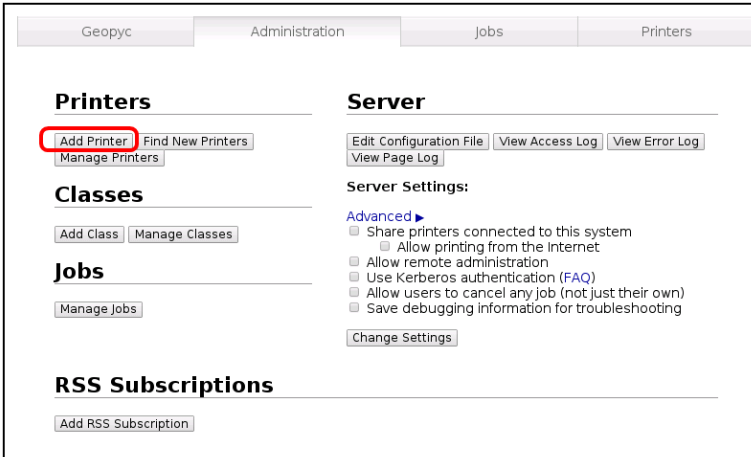

4. Select the printer to add then tap **Continue**.

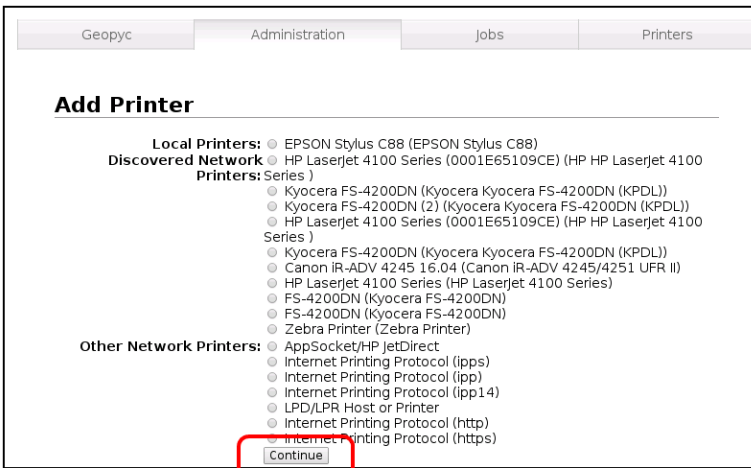

5. Enter information about the printer then tap **Continue**.

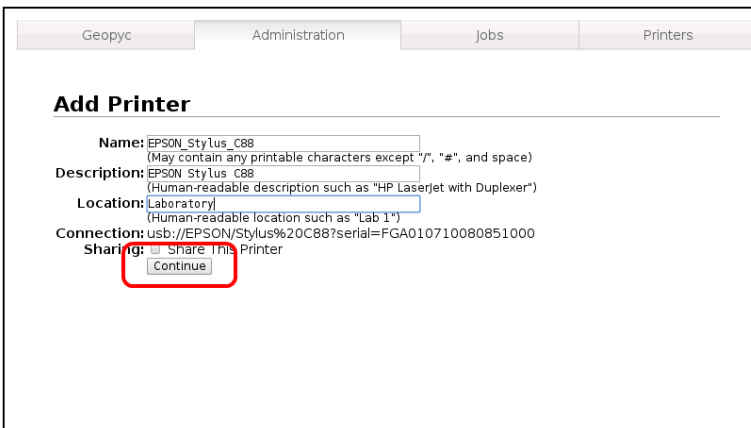

6. Select the printer model from the *Model* drop-down list then tap **Add Printer**.

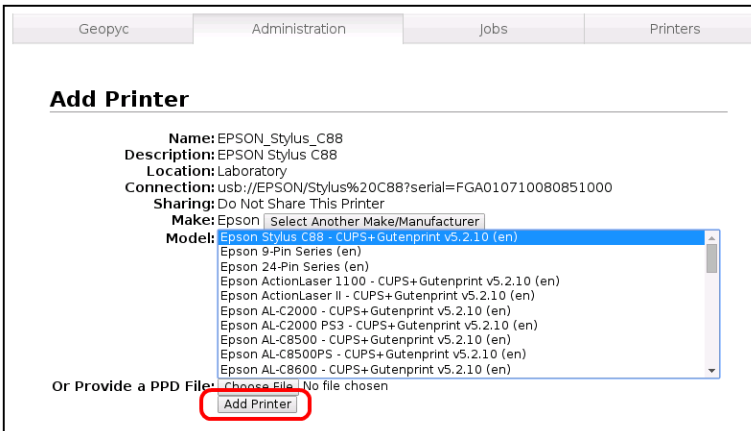

7. Select printer settings from the drop-down lists then tap **Set Default Options**.

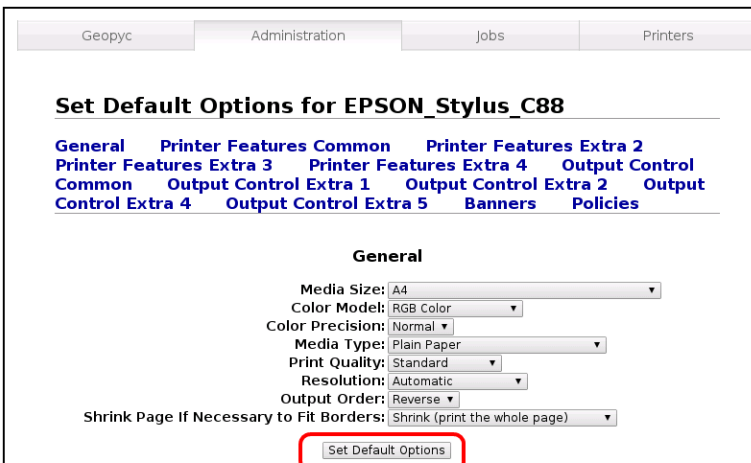

8. Tap the *Printers* tab. The installed printer displays.

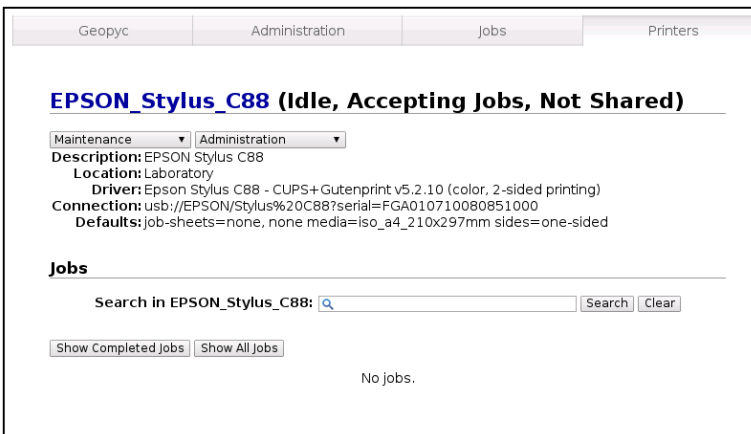

REFRESH THE BROWSER

[Power Instrument On and Off on page 6 - 9](#)

If a keyboard is attached or removed from the instrument, the browser will need to be refreshed.



One method to refresh the browser is to power the instrument OFF, attach or remove the keyboard, then power the instrument back ON. Alternatively, use the following instructions.

Attach a keyboard and refresh the browser:

1. Attach the keyboard.
2. Press **F5** or **Ctrl+R** on the attached keyboard. When the browser completes the refresh process, the virtual keyboard will be disabled and the attached keyboard can be used.

Remove the keyboard and refresh the browser:

1. Press **Ctrl+W** on the attached keyboard.
2. Remove the keyboard before the browser refresh process completes. When the browser completes the refresh process, the virtual keyboard can be used.

CLEAN THE INSTRUMENT

The exterior casing of the instrument may be cleaned using a clean, lint-free cloth dampened with isopropyl alcohol (IPA), a mild detergent, or a 3% hydrogen peroxide solution. Do not use any type of abrasive cleaner. It is not necessary to remove knobs, screws, etc. while cleaning.



Do not allow liquid to penetrate the casing of the instrument. Doing so could result in damage to the unit.

TROUBLESHOOTING AND MAINTENANCE

[Clean the Instrument above](#)

[Instrument Status on page 1 - 6](#)

[Maintenance on page 6 - 1](#)

[Power Instrument On and Off on page 6 - 9](#)

[Printer Installation on page 6 - 11](#)

The *Error Messages* document can be found on the Micromeritics web page (www.Micromeritics.com).

A CONVERSION FACTOR

To calculate the volume of the chamber contents, the analyzer converts displacement data to volume data using a conversion factor. The conversion factors are based on the geometry of the chamber and are adjusted to account for the consolidation of the Dry Flo and the friction of the plunger's movement. The *Calculations* document can be found on the Micromeritics web page (www.Micromeritics.com).

Adjusted Conversion Factors

Internal Chamber Diameter (mm)	Conversion Factor (adjusted) (cm ³ /mm)
12.7	0.1284
19.1	0.2907
25.4	0.5153
38.1	1.1492
50.8	2.0373

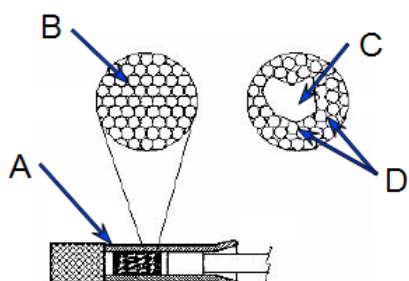

- A. Chamber
- B. Regularly consolidated Dry Flo
- C. Sample
- D. Irregularities in Dry Flo consolidation caused by sample

The conversion factors in the table are average volumes representative of many types of materials when consolidated with Dry Flo. However, the irregularities of the sample's surface and shape may create slight irregularities in the consolidation of the Dry Flo. The accuracy of data decreases if these irregularities are not compensated.

The conversion factor can be calibrated to reflect the irregularities of the sample by performing a calibration run. After performing a calibration run, the calibrated conversion factor can be used during other runs, so that analysis data are adjusted for the way the sample affects the Dry Flo.



- For best results, perform several calibration runs for a given sample type. Discard any extreme results. Use the average of the resulting calibrated conversion factors when analyzing samples of this type.
- Conversion factors are specific to each chamber. A conversion factor calculated for one chamber should not be used for runs with another chamber.

To maximize accuracy, it is strongly recommended to calculate the conversion factor by performing a calibration run. The conversion factor from the table can be used, however the results will not be as accurate as performing a calibration run.

B DISPLACEMENT VOLUME

To calculate the envelope density of a sample, the analyzer first determines its envelope volume. A quantity of Dry Flo is placed in the sample chamber and the medium's volume is measured (called a blank run). A sample is then placed in the chamber with the medium, and the volume is measured again (a sample run). Because Dry Flo does not enter the sample's pores, the difference between the two measurements is the displacement volume of the sample including that of its pores (the envelope volume). The analyzer then uses the envelope volume and the sample's weight to calculate its envelope density.

Irregularly shaped samples and multiple samples may be accurately analyzed because Dry Flo basically conforms to the contours of surfaces. However, no dry-fluid medium can conform to an object as perfectly as a nonwetting liquid, nor can it respond equally to all types of surface irregularities. With agitation, however, it does respond reproducibly. The analyzer compensates for irregularities in the consolidation of the Dry Flo by allowing calibration with an object of known properties that is similar to the sample in size and shape.

**This page
intentionally
left blank**

C DRY FLO



Dry Flo was carefully formulated to produce accurate results without harming the analyzer. Use of any other medium with the analyzer may give inaccurate results or damage the plunger seal, and could invalidate the warranty of the analyzer.

Dry Flo is made of tiny, rigid beads and a small amount of dry lubricant. It can be handled safely with a minimum of equipment. Dry Flo flows freely over surfaces and readily shakes or brushes off most objects unless the objects are wet or sticky. Dry Flo can be handled and measured with ordinary laboratory utensils — such as funnels, scoops, and beakers — made of metal, plastic, paper, glass, or other materials. Utensils must be clean and dry. Use isopropyl alcohol to clean the utensils.

Dry Flo is minimally contaminating, and most samples can be used in other tests after a light shaking or brushing. Should surface roughness trap a few beads, the effect on subsequent testing or use is negligible in most cases.



Dry Flo should be handled with care to avoid creating dust while breathing. Gloves, protective clothing, and protective glasses should be worn when handling Dry Flo.

Dry Flo is not harmful to skin, however residue from Dry Flo may remain on surfaces and may mark or stain fabrics or paper.

HOW TO HANDLE DRY FLO

- Use a spoon or scoop to move small amounts of Dry Flo from one container to another.
- Use soap and water to clean residue off hands.
- For consistent results, shake the bottle of Dry Flo periodically to remix the contents.
- Pour Dry Flo gently to avoid splashing (use a funnel to facilitate pouring). Do not drop samples into the medium; instead, slide them gently down the side of the chamber.
- Use a soft paintbrush to remove clinging particles of Dry Flo from surfaces.
- Use a sieve to recover samples after analysis. A 75 mm diameter sieve with 350 to 500 mm openings retains the sample and allows the Dry Flo to pass through freely. A sieve pan and sieve are included in the accessories.
- Dry Flo sometimes becomes compacted during analysis. Shake the chamber / plunger assembly to loosen the Dry Flo.



Brush away any Dry Flo clinging to the bottom of the chamber or the top of the plunger to ensure proper mounting on the analyzer. Because the accuracy of the GeoPyc's calculations relies on precise measurements of the distance traveled by the plunger, debris trapped between the chamber / plunger and the analyzer can affect results.

- Discard used Dry Flo since small amounts of lubricant are lost during analysis. It is possible to reuse Dry Flo, but high-precision results may not be achieved.

The analyzer comes equipped with a rubber mat to catch Dry Flo that may spill onto the platform beneath the analysis chamber.

AMOUNT OF DRY FLO TO USE

These guidelines provide a general idea of how to estimate the amount of Dry Flo to use. There is no exact or specific amount of Dry Flo that is correct for any sample.

Use enough Dry Flo to surround the sample or calibration object on all sides. There must be sufficient Dry Flo to surround the object to become consolidated during the analysis process. Accuracy is impossible when using an insufficient amount of Dry Flo (the sample bed cannot be consolidated) and reduced when there is too much (relative change is not maximized).

Ideally, the final bed of sample plus Dry Flo should consist of approximately 1/3 sample and 2/3 Dry Flo. However, at minimum, the sample must constitute at least 1/4 of the final bed. This illustration shows how to determine the appropriate amount of Dry Flo.

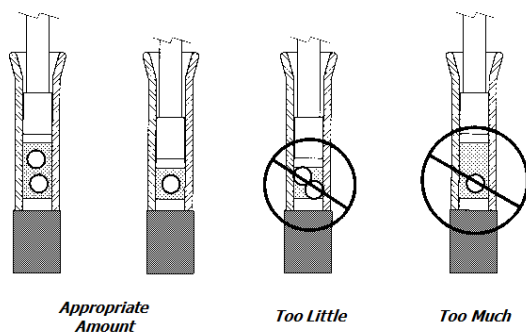

Method A

Place the sample in the chamber and push the plunger into the chamber until it touches the sample. Mark the level of the plunger seal with a grease pencil or tape. Remove the plunger, then the sample, and:

- For single objects, fill the chamber with Dry Flo to the marked line.
- For multiple small objects, fill the chamber with Dry Flo to the marked line, then double this amount. If adding sufficient Dry Flo causes the sample plus medium bed to exceed the maximum length specified in the table [Chamber Parameters on the next page](#), use a smaller amount of sample.

Method B

Place the sample in the chamber. Fill with Dry Flo until the sample is covered with Dry Flo. Ensure there is sufficient Dry Flo to completely surround the sample during analysis. Use a sieve to recover the sample. Return the Dry Flo from the sieve pan to the chamber.

To Load the Chamber

Use one of the methods above to load the chamber with Dry Flo. Load the sample object and slide the plunger part way into the chamber. Shake the chamber to help the object become surrounded by the Dry Flo.

Push the plunger into the chamber until visible air space is gone. Repeat shaking the chamber and adjusting the plunger as needed. The object should no longer be visible. If the object is still visible, or if it appears to be touching either the plunger or the chamber bottom, then the amount of Dry Flo is not sufficient.



Avoid final sample plus Dry Flo beds that are significantly longer than their diameter. If the samples are long and thin, analyze several of them in a larger chamber to avoid a long, thin Dry Flo bed.

The *Chamber Parameters* table provides guidelines to help in loading the chamber with an appropriate amount of Dry Flo.

Chamber Parameters

Internal Chamber Diameter (mm)	Envelope Volumes Best Measured (cm³)	Maximum Length of Medium and Sample when Consolidated (mm)
12.7	0.3 - 0.8	19
19.1	0.8 - 2.4	28
25.4	2.4 - 5.3	38
38.1	5.3 - 13	50
50.8	13 - 26	55

WEIGH DRY FLO

When storing blank data, the quantity of Dry Flo used in each run must be entered. This quantity is called the chamber + medium mass. This step is not necessary when performing a single blank run embedded in a sample or calibration run.



Accurately weighing the Dry Flo is critical for obtaining acceptable results using stored blank data. A precision analytical balance accurate to 1 mg is required. If this level of accuracy cannot be achieved, the technique of using stored blank data may not be satisfactory.

It is recommended to weigh Dry Flo in the analysis chamber. This reduces the possibility of error in transferring Dry Flo from a weighing container to the chamber.

If it is necessary to transfer the Dry Flo from a weighing container to the chamber, ensure that no Dry Flo is lost in the process. Avoid splashing. Any Dry Flo clinging to the weighing container or flared end of the chamber must be brushed back into the chamber. A small amount of Dry Flo residue remaining in the measuring container will affect analysis results.

When prompted, enter the chamber + medium mass. Enter either the mass of the chamber plus Dry Flo or the mass of the Dry Flo only. Including or excluding the chamber's mass does not affect analysis calculations; however the same method for both the blank and sample runs for a given sample must be used. If, for example, including the chamber's mass in the blank run, then include the chamber's mass in the sample run.

DRY FLO BED

If too little sample is used, poor reproducibility of results will occur. The instrument is unable to distinguish between a Dry Flo bed with sample and one without sample when the sample volume occupies too small a percentage of the total bed. For optimum performance, the sample should occupy a minimum of 20% of the Dry Flo bed. A larger percentage of sample is preferable as long as it can be surrounded sufficiently by Dry Flo.

Each sample cell requires calibration without Dry Flo or sample to determine the *zero bed* volume. This information is stored internally and, thereafter, the percent sample volume is reported with each analysis. This number can then be used to optimize the quantity of sample necessary to meet a specific reproducibility criteria.

The following table and graph show the typical effect of sample quantity on the reproducibility of results. The sample used in this example was composed of varying quantities of nonporous glass spheres 6 mm in diameter. The analyses were conducted using a 25.4 mm diameter sample cell. The absolute density of the spheres was 2.5202 g/cm³ as measured by Micromeritics' AccuPyc. Being nonporous, the envelope density of the spheres was also 2.5202 g/cm³. As shown, this value is achieved within 1% when the sample occupies more than 7.5% of the total bed volume. Other materials will exhibit similar behavior but may not follow this exact pattern.

Typical Effect of Sample Quantity on the Reproducibility of Results

% Sample Volume	Envelope Density	% Error
0.537	2.8223	+11.99
1.228	2.5416	+0.85
1.284	2.4177	-4.07
1.299	2.3913	-5.11
1.944	2.3903	-5.15
3.012	2.5419	+0.86
4.782	2.5518	+1.25
5.761	2.5699	+1.97
7.523	2.5288	+0.34
9.616	2.5269	+0.27
12.547	2.5386	+0.73
14.063	2.5193	-0.04
15.538	2.5041	-0.64
18.039	2.5184	-0.07

Typical Effect of Sample Quantity on the Reproducibility of Results (continued)

% Sample Volume	Envelope Density	% Error
18.335	2.5089	-0.45
18.706	2.5155	-0.19
20.333	2.5153	-0.19
29.708	2.5289	+0.35

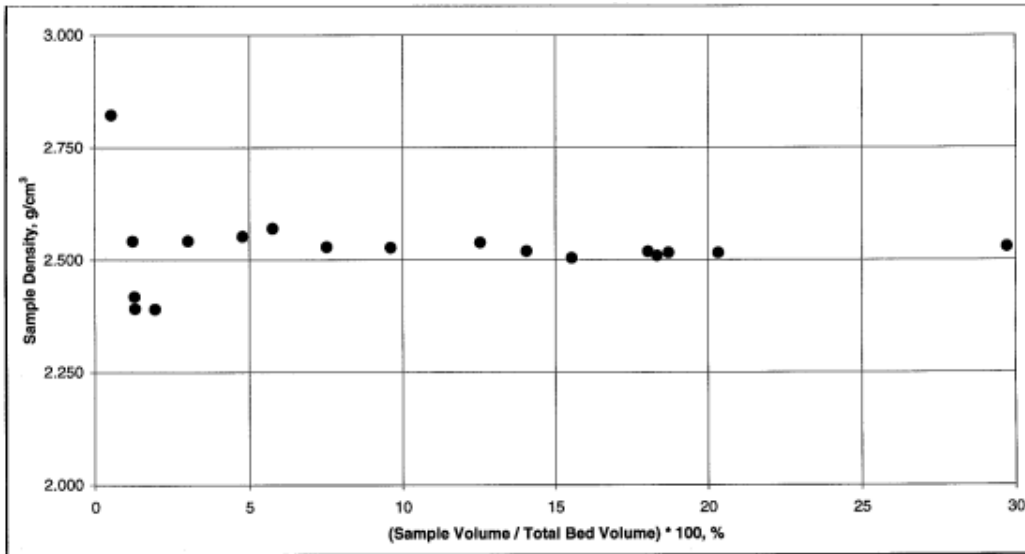

**This page
intentionally
left blank**

D ENVELOPE DENSITY

REPRODUCIBILITY

Achieving high reproducibility in any analytical measurement often requires performing tests in an identical manner using a single instrument, fixed instrument parameters, and the same quantity of test material. This is particularly true with the GeoPyc technique because it is very sensitive to procedural variations and deviations in test parameters. Reproducibility of results of approximately $\pm 1.0\%$ can be expected when parameters are controlled to the fullest extent possible. A description of these parameters and the criteria that must be observed to achieve this level are described below.

Envelope density is calculated from specimen mass and envelope volume, that is, volume including both open and closed pores. This volume is measured using Dry Flo, which is confined in a cylindrical sample chamber having one of five diameters from 12.7 mm (0.5 in.) to 50.8 mm (2.0 in.). The volume of the specimen is determined by subtracting the volume of consolidated Dry Flo (blank run) in a sample chamber from the volume of the same consolidated Dry Flo in the same chamber with the specimen included (test run). The medium bed is agitated through rotation and vibration, and the consolidation force is gradually increased to the same set value in both phases of a test.

1. The first criterion for a GeoPyc analysis is that the Dry Flo consolidate identically in the blank and test runs. Repeated testing of the medium alone has shown that, almost without exception, it actually consolidates with a reproducibility of $\pm 0.34\%$ or better in all size sample chambers for bed depths of one-half to twice the chamber diameter. Somewhat better reproducibility of $\pm 0.25\%$ is typically achieved when the bed depth is restricted to approximately the chamber diameter. In any event, between one-third and one-quarter of the minimal overall error of $\pm 1.0\%$ is due to the nonideal behavior of Dry Flo.

Guideline 1. Start an analysis with a Dry Flo bed depth a little less than the chamber diameter.

2. Sample quantity plays the most significant role in reproducibility. Obviously, the specimen extracted from a larger quantity of material must be of sufficient quantity to be representative of the whole. The quantity of sample determines the minimum sample chamber size required for analysis. A chamber should be selected in which the sample constitutes a minimum of 20% of the total sample plus Dry Flo volume when consolidated. A larger percentage of sample is preferable; however, keep in mind that the sample must always be surrounded sufficiently by Dry Flo.

Every envelope density result is derived from the difference in two volumes, the consolidated Dry Flo and the consolidated Dry Flo with sample. That difference should be as large as possible simply for mathematical significance.

For example, in one series of tests on a typical granular product where the product volume relative to the bed volume was varied from 6.9 to 41.7%, there was almost a 9.0% variability in envelope density. At the highest percentage, the sample quantity may have been sufficient for bridging of sample pieces to interfere with medium consolidation. At the lower percentage, small errors in consolidation were magnified in the difference value. However, the envelope volume within a $\pm 1.3\%$ error band was registered when the sample volume ranged from 30 to 35%. The current program for the GeoPyc automatically calculates the sample volume percentage. This percentage is a useful guide to optimum performance and should always be considered when assessing the validity of results.

Guideline 2. Select sample chamber dimensions, Dry Flo volume, and specimen quantity to yield a sample volume percentage of at least 20%.

3. The error band was reduced to $\pm 0.95\%$ when another series of tests was run with the material used in the above guideline and both Dry Flo and sample weights were held constant to the third decimal place. The reported sample-to-bed volume varied only between 32.1 and 33.4% in this case. Such control is not practical or even feasible in many instances, but this technique should be considered when possible.

Guideline 3. Maintain constant all parameters susceptible to control for optimum reproducibility.

4. Both the blank and test steps of an envelope density determination consist of an equal number of preparation and analysis cycles.

Preparation cycles are unrecorded, repetitious, agitation and consolidation attempts intended to orient the Dry Flo grains and the specimen into a uniformly mixed bed. Analysis cycles follow the preparation cycles and yield statistical information on consolidated volumes. The bed is expected to become more and more consolidated during the preparation cycles, but little or no consistent increase or decrease in value should be evident in the analysis cycles. Diminishing information can be gleaned once the cycles exceed a certain number. The results presented above were primarily obtained with 10 preparation and 5 analysis cycles. Some specimens require more, but fewer are adequate in other cases; 10 preparation and 5 analysis cycles are good starting numbers.

Guideline 4. Choose the number of preparation and analysis cycles such that little or no consistent increase or decrease in value is revealed by the recorded data.

ACCURACY

Follow the guidelines for reproducibility (see [Reproducibility on page D - 1](#)). Those guidelines must be followed, in conjunction with the guidelines listed below, to produce accurate envelope density measurements.

1. Sample shape influences GeoPyc results, but the effect cannot be rigorously quantified because shape itself is subject to infinite variation. The GeoPyc handles this problem by calibration. Two calibration values for each sample chamber (conversion factors), are noted in the operator's manual included with the GeoPyc.

The first conversion factor (calculated factor) is derived from geometry and mechanical couplings and relates the plunger movement to chamber volume as if there were no sample shape influence. The second factor (adjusted factor) is modified to include an average shape influence experimentally determined from many different shapes. Neither is likely to apply precisely to any particular specimen. True calibration for shape can be achieved only when the predetermined envelope density of a representative specimen of the material in question is used.

The representative specimen preferably is one from an evaluation procedure that was being followed before GeoPyc introduction. GeoPyc results can be expected then to track prior records. A completely nonporous specimen of the same shape as the material in question affords a degree of calibration but, because it is nonporous, cannot have the same surface texture and cannot be as satisfactory. Because in the final analysis the GeoPyc operates best as a comparison device, there is no real substitute for a truly representative specimen for calibration. A GeoPyc operator should set aside enough of the selected calibration material to be able to recheck the calibration from time to time.

Guideline 1. Select for calibration a quantity of the material in question and determine its envelope density by the prior test procedure or some other method.

2. Calibration itself will only be reproducible to the degree the guidelines given earlier for reproducibility are followed. Accordingly, the mass of the representative sample, the quantity of Dry Flo, and the sample chamber size should be selected on the basis of the amount of sample to be used later. Also, all calibration tests should be made with the same consolidation force and the same number of preparation and test cycles to be used in analyses.

Guideline 2. Conduct calibration tests using parameters identical to those to be used in analyses.

3. Finally, a number of calibration tests should be made and the median selected as the conversion factor.

Guideline 3. Use the median value from a number of calibration tests as the conversion factor for the material to be analyzed.

**This page
intentionally
left blank**

E MEASUREMENT METHOD

The distance the plunger moves into the chamber is the actual measurement with which calculations are made. This distance is measured by the number of steps moved by the stepper motor that drives the plunger. The plunger moves along a screw; the diameter and threading of the screw enter into the calculations. The *Calculations* document can be found on the Micromeritics web page (www.Micromeritics.com).

**This page
intentionally
left blank**

F ZERO DEPTH OF A SAMPLE CHAMBER

GeoPyc > [select a Zero Depth SOP from the drop-down list]

The analyzer determines the distance the plunger moves into an empty sample chamber to obtain the zero depth of the chamber. This value is used after an analysis to calculate the percent of sample volume in the sample bed.

Zero depth measurements can be entered for each chamber in Maintenance view.

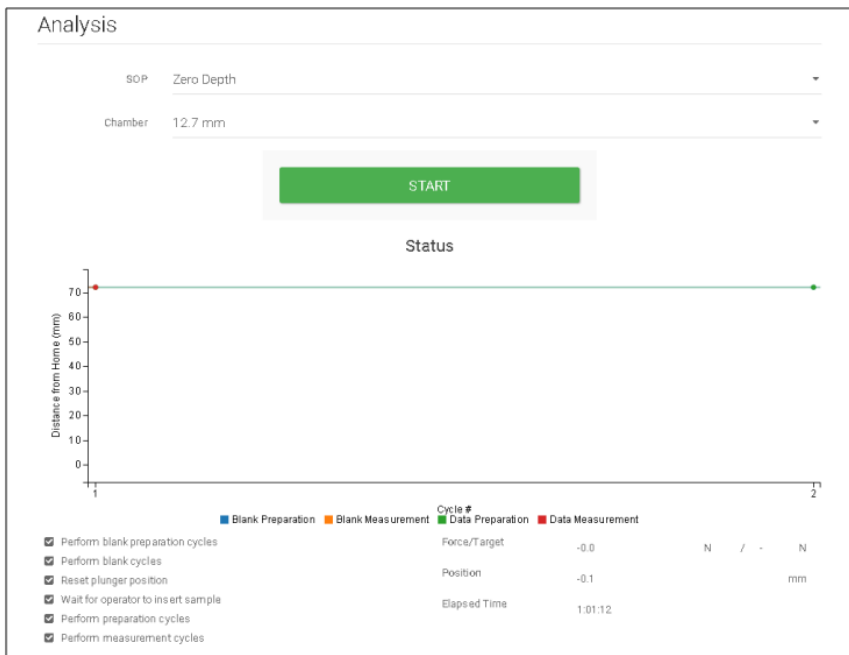

THE PERCENT SAMPLE VOLUME

Sample quantity plays a significant role in reproducibility. A specimen extracted from a larger quantity of material must be of sufficient quantity to be representative of the whole. The specimen used determines the minimum sample chamber size required for analysis. A sample chamber should be selected in which the sample will constitute approximately 25% of the sample bed (sample plus Dry Flo).

The sample volume percent is included in the *Envelope Density Report*. View this report to ensure that the sample bed contains an adequate amount of sample.

PISTON COUPLING EXTENDERS

Piston coupling extenders are required when performing zero depth runs. The piston coupling extender screws onto the standard piston rod between the piston and the coupling.

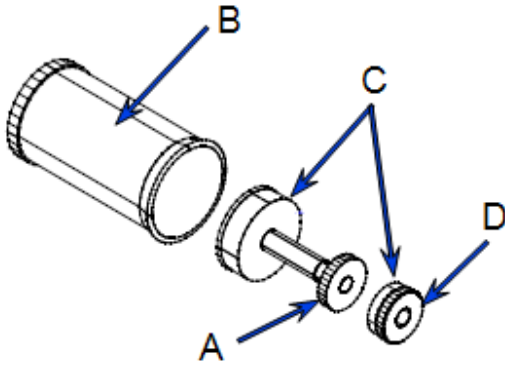

- A. Piston rod
- B. Chamber
- C. Plunger
- D. Extender

G T.A.P. DENSITY

[SOP \(Standard Operating Procedures\) on page 4 - 1](#)



T.A.P. (Transverse Axial Pressure) density is an optional software upgrade.

To measure bulk density, the GeoPyc consolidates the sample within a cylindrical chamber until a specific force is achieved. A measurement is taken at that point, and subtracted from blank (empty chamber) data stored in the GeoPyc to yield the sample's bulk volume. This volume and the sample's mass are used to calculate bulk density. When you begin a bulk density analysis with the GeoPyc, you must enter the force with which you wish the sample to be consolidated at the time the measurement is taken.

The GeoPyc allows the use of either force (in newtons) or pressure (in newtons/cm²) as the unit for measuring consolidation of the sample. In this section, pressure is used, but all information is applicable when force is used.

A wide range of pressures can be used. If a small pressure is entered, the sample may simply be consolidated loosely. If a great pressure is used, the sample may be thoroughly consolidated, eliminating much of the void space among the particles or granules. Still further consolidation may cause individual sample particles to collapse, shatter, or be distorted, especially if the sample is fragile or soft. In some instances, the purpose of the experiment may be to observe the sample's performance and quantify its density under a range of pressures. For example, such a study might be useful in packaging and shipping bulk granular products.

In many cases, though, the purpose of the experiment is to determine the sample's bulk density, as compared to historical product data obtained using the older *tap* density method¹⁾. In such cases, it is necessary to enter the level of pressure that corresponds to the degree of sample compaction at which the *tap* density was measured. Tap density instruments do compact the sample to a specific degree, but —unlike the GeoPyc— they may not provide any way to quantify that degree.

1) ASTM Standard Test Method B 527-81, Tap Density of Powders of Refractory Metals and Compounds by Tap-Pak Volumeter.

Recommended Force or Pressure for Emulating Tap Density

Internal Chamber Diameter (mm)	Recommended Pressure Range for Emulating Tap Density (N/cm ²)	Recommended Force Range for Emulating Tap Density (N)
12.7 *	*These chambers are not recommended for emulating tap density. They are very useful, however, for assessing sample compaction at higher pressures.	
19.1 *		
25.4	1 to 3	5 to 15
38.1		11 to 33
50.8		20 to 60



EU DECLARATION OF CONFORMITY

This declaration of conformity is issued under the sole responsibility of the manufacturer:

Micromeritics Instrument Corporation
4356 Communications Drive
Norcross, GA 30093, USA

Hereby declares that the product:

GeoPyc 1365 Envelope and Density Analyzer

is in conformity with the following **EU harmonization legislation**:

2014/35/EU - LVD Directive
2014/30/EU - EMC Directive
2011/65/EU - RoHS Directive

and that the equipment is in conformity with the following harmonized and other appropriate standards;

2014/35/EU (LVD)

IEC 61010-1:2010/AMD:2016 - *Safety requirements for electrical equipment for measurement, control, and laboratory use — Part 1: General requirements.*

IEC 61010-2-081:2019 – *Particular requirements for automatic and semi-automatic laboratory equipment for analysis and other purposes.*

2014/30/EU (EMC)

IEC 61326-1:2020 Ed.3 - *Electrical equipment for measurement, control and laboratory use — EMC requirements — Part 1: General requirements*

IEC 61000-3-2:2018 /AMD1:2020 - *Part 3-2: Limits — Limits for harmonic current emissions (equipment input current ≤ 16 A per phase)*

IEC 61000-3-3:2013 - *Part 3-3: Limits — Limitation of voltage changes, voltage fluctuations and flicker in public low-voltage supply systems, for equipment with rated current ≤ 16 A per phase and not subject to conditional connection*

2011/65/EU (RoHS)

EN 63000:2018 - *Technical documentation for the assessment of electrical and electronic products with respect to the restriction of hazardous substances*

Name: John McCaffrey, Ph.D.

Title: Vice President, R & D

Signature: _____

Date of issue: 03/20/2023

Location: Norcross, GA USA



UK DECLARATION OF CONFORMITY

This declaration of conformity is issued under the sole responsibility of the manufacturer:

Micromeritics Instrument Corporation
4356 Communications Drive
Norcross, GA 30093, USA

Hereby declares that the product:

GeoPyc 1365 Envelope and Density Analyzer

is in conformity with the following UK legislation:

Electrical Equipment (Safety) Regulations 2016

Electromagnetic Compatibility Regulations 2016

Restriction of the Use of Certain Hazardous Substances in E&E Equipment Regulations 2012

and that the equipment is in conformity with the following designated and other appropriate standards;

Electrical Equipment (Safety) Regulations 2016

IEC 61010-1:2010/AMD1:2016 - *Safety requirements for electrical equipment for measurement, control, and laboratory use — Part 1: General requirements.*

IEC 61010-2-081:2019 – *Particular requirements for automatic and semi-automatic laboratory equipment for analysis and other purposes.*

Electromagnetic Compatibility Regulations 2016

IEC 61326-1:2020 - *Electrical equipment for measurement, control and laboratory use — EMC requirements — Part 1: General requirements*

IEC 61000-3-2:2019 - *Part 3-2: Limits — Limits for harmonic current emissions (equipment input current ≤ 16 A per phase)*

IEC 61000-3-3:2013 - *Part 3-3: Limits — Limitation of voltage changes, voltage fluctuations and flicker in public low-voltage supply systems, for equipment with rated current ≤ 16 A per phase and not subject to conditional connection*

Restriction of the Use of Certain Hazardous Substances in E&E Equipment Regulations 2012

EN 63000:2018 - *Technical documentation for the assessment of electrical and electronic products with respect to the restriction of hazardous substances*

Name: John McCaffrey, Ph.D.

Title: Vice President, R & D

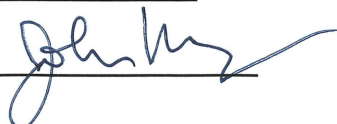
Signature: 

Date of issue: 03/20/2023

Location: Norcross, GA USA