

MICROMERITICS-CIRRUS

INTERFACE



INSTALLATION INSTRUCTIONS

292-42805-00
Nov 2016
(Rev C)

TRADEMARKS

Cirrus is a trademark of MKS Instruments, Inc.

Hastelloy is a registered trademark of Haynes International, Inc.

Micromeritics is a registered trademark of Micromeritics Instrument Corporation.

Microsoft, Windows, and Windows 7 are registered trademarks of Microsoft Corporation.

Valco is a trademark of Valco Instruments Co. Inc.

Copyright

The software described in this manual is furnished under a license agreement and may be used or copied only in accordance with the terms of the agreement.

CONTACT US

Micromeritics Instrument Corporation

4356 Communications Drive
Norcross, GA / USA / 30093-2901
Phone: 1-770-662-3636
Fax: 1-770-662-3696

www.Micromeritics.com

U.S. Inquiries

U.S. Sales Phone: 1-770-662-3636

USSales@Micromeritics.com

Quotes, Orders, and Customer Satisfaction

Customer Service Phone: 1-770-662-3636

Orders@Micromeritics.com

U.S. Instrument Service Department

U.S. Service Department Phone: 1-770-662-3666

Service.Helpdesk@Micromeritics.com

Micromeritics Scientific Services

[Customer Support Portal](#)

<http://techsupport.micromeritics.com/portal>

ABOUT THIS MANUAL

The following formats are used throughout this manual:



NOTE - Notes contain important information pertinent to the subject matter.



CAUTION - Cautions contain information to help prevent actions that may damage the analyzer or components.

Table of Contents

Contact Us	i
About this Manual	ii
Introduction	1
Software	1
Hardware	1
Hardware Installation	2
AutoChem 2920 (Serial Numbers 700 and Below)	2
AutoChem 2920 (Serial Numbers 701 and Above)	9
AutoChem HP 2950	14
3Flex 3500 Chemisorption	17
ASAP 2020 Chemisorption	18
Connect Cables	20
Mass Spectrometer to AutoChem Analyzers	20
Mass Spectrometer to 3Flex 3500 Chemisorption Analyzer	21
Mass Spectrometer to ASAP 2020 Chemisorption Analyzer	22
Pin-Outs for Mass Spec Connectors	24
Software Installation and Operation Preparation	28
Micromeritics Custom Recipe Installation	28
Set Up and Prepare for Operation	32
Power Off the Mass Spectrometer	34
Parts and Accessories	35

Blank Page

INTRODUCTION

SOFTWARE

The *Micromeritics-Cirrus Interface Software* is used with select Micromeritics analyzers integrated with an MKS Cirrus Mass Spectrometer. This software runs within the *MKS Process Eye Professional* application. The Micromeritics-Cirrus Interface Software will perform the following tasks:

- Automatically collect data with the Cirrus Mass Spectrometer via trigger signal from the Micromeritics analyzer
- Customize *Peak Jump* recipes
- Access standard operations such as Analog scan, Barchart scan, Peak Jump scan, Leak Check, and data storage
- Calibrate detectors
- Scale the Micromeritics analyzer sample thermocouple signal

Refer to the *Micro-Cirrus Interface User Guide* (part number 292-42804-00) for details on operating the interface software.

HARDWARE

The Mass Spectrometer requires periodic maintenance. Allow adequate space for accessing connections and cables, as well as for ventilation. Refer to the *Cirrus 2 Hardware Manual* for information pertinent to the Mass Spectrometer.

HARDWARE INSTALLATION

AUTOCHEM 2920 (SERIAL NUMBERS 700 AND BELOW)

REQUIRED TOOLS

- Phillips head screwdriver
- 1/4 in. open-end wrench
- 3/8 in. open-end wrench
- 5/16 in. open-end wrench
- 7/16 in. open-end wrench
- 9/16 in. open-end wrench

The Mass Spectrometer connector is located on the side panel of the analyzer.

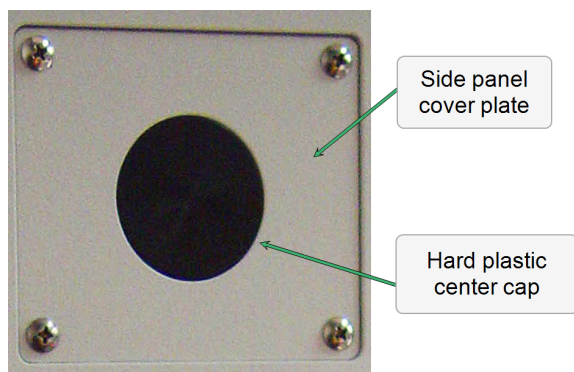

The TCD and cold trap valve zones of the AutoChem must be cool to allow safe handling of components. If necessary, allow a few hours for the zones to cool down after setting the zones to 20 °C. Removing the cover and insulation at the zones will speed the cooling process. The following illustration shows the original plumbing of the TCD/Cold Trap zone.

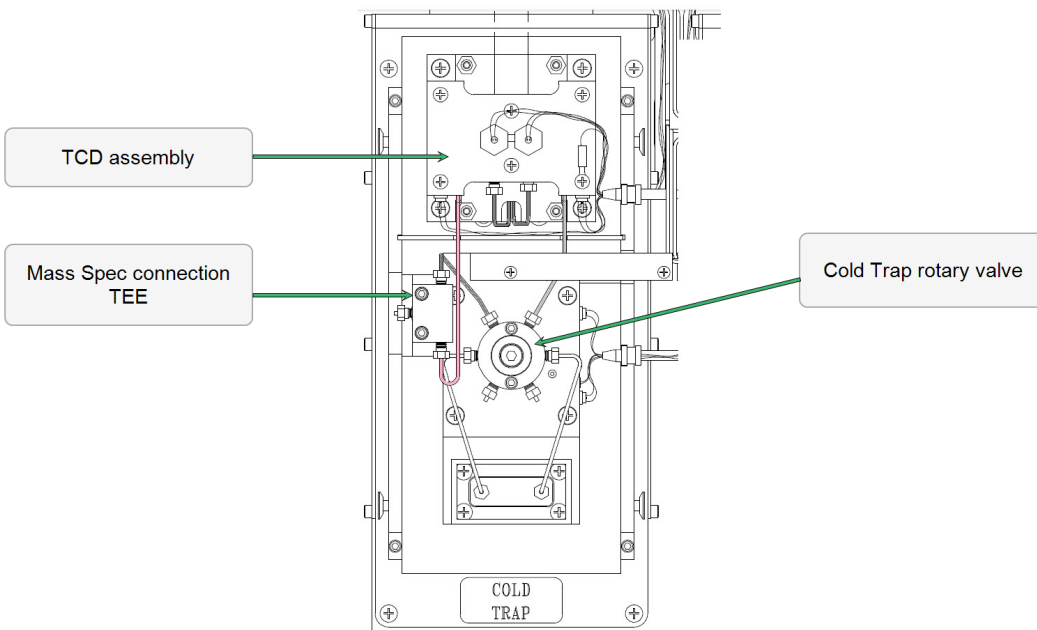

1. Remove the rear panel and the entire top panel of the analyzer to allow full access to the plumbing.
2. Remove the aluminum metal plate which covers the tubes inside the grooved bar inside the heated zone. **NOTE:** This aluminum plate will not be re-used.
3. Loosen the screws which retain the plastic hose clamps, remove the side panel cover plate, then remove the hard plastic center cap. Save the screws for later.

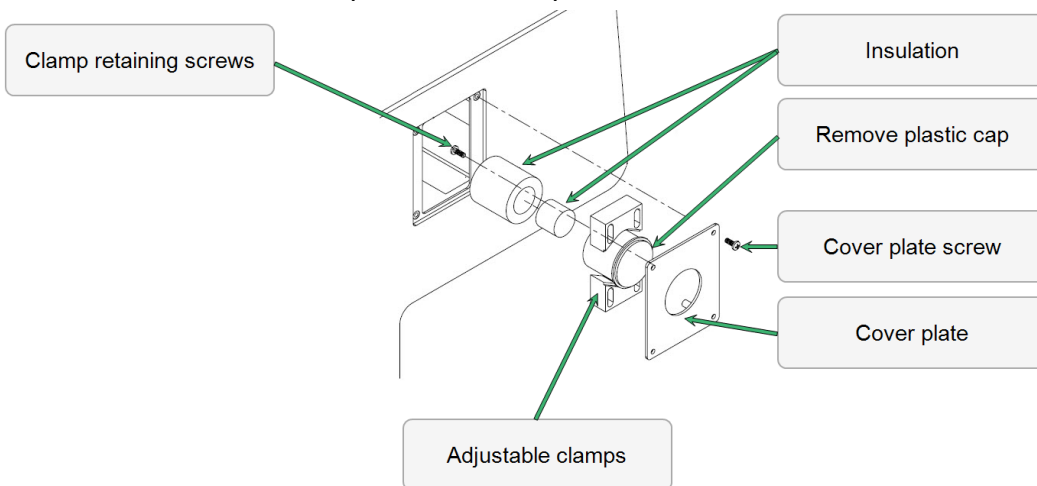

4. Remove the 1/8 in. tube from the sample exhaust side of the TCD. Disconnect the other end at the hexagonal fitting, which is above the side panel exhaust ports.

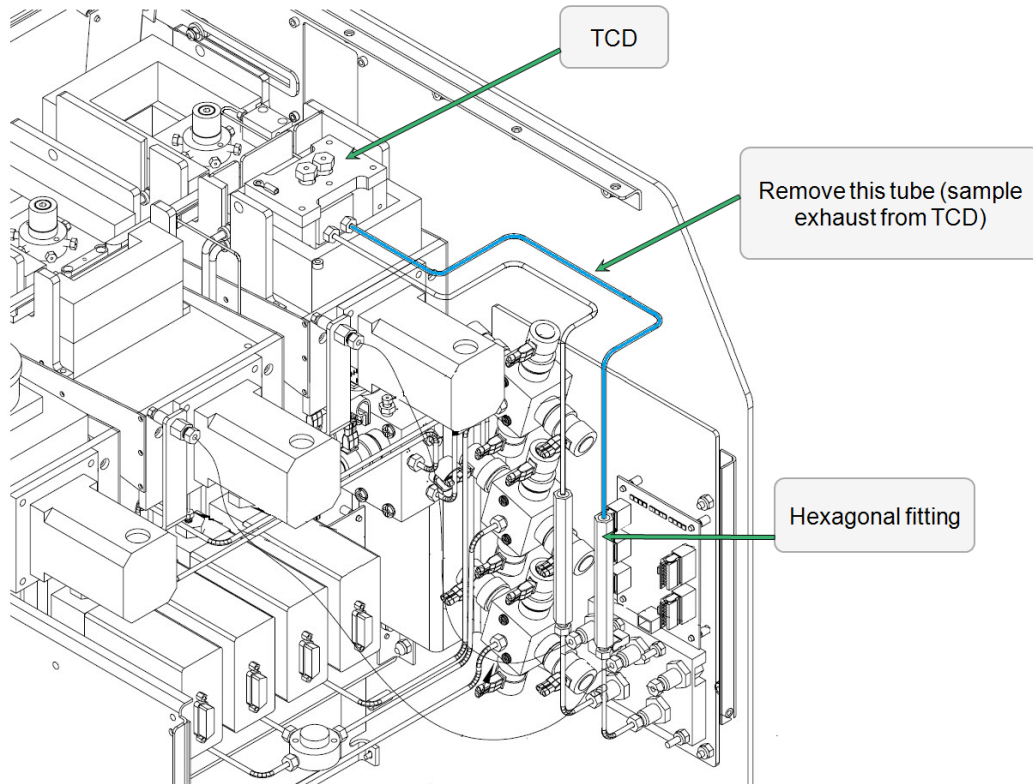

5. Remove the two tubes that enter the ends of the TEE block. Remove the plug from the side of the TEE block.
6. Remove the screws that hold the TEE block to the heated plate. An Allen wrench is provided in the parts and accessories kit. Remove the two screws which hold the cover plate to a grooved channel. Remove the cover plate.

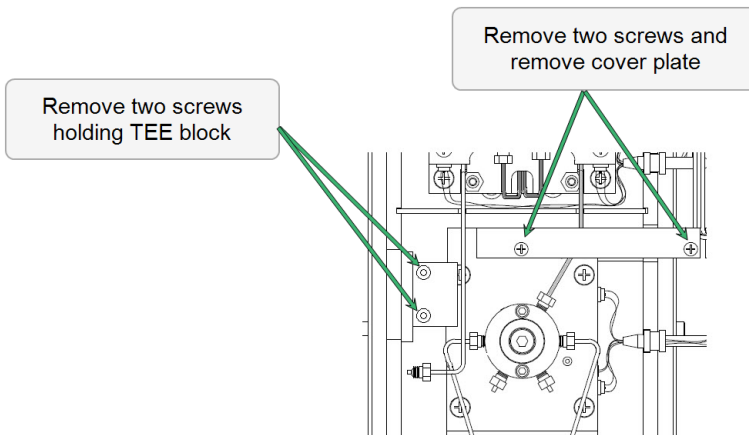

7. Remove the screw from the grooved channel.

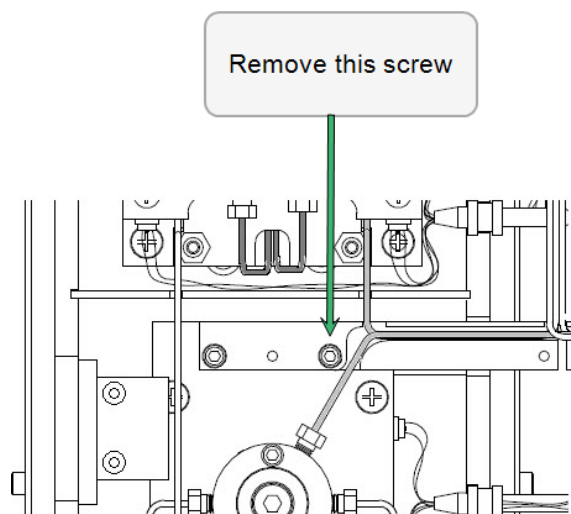

- The tube that connected to the TEE (at the port that was closest to the front of the instrument) must be connected to the rotary valve at the unoccupied port. This tube is shown on the left side of the following illustration.



The 1/16 in. tubes are longer than required. **DO NOT CUT THE TUBES.** The tubing has been cut, deburred and cleaned. Further cutting will introduce small particles which can cause problems. If the tube is too long, either coil or zig-zag the tube to use the excess length.

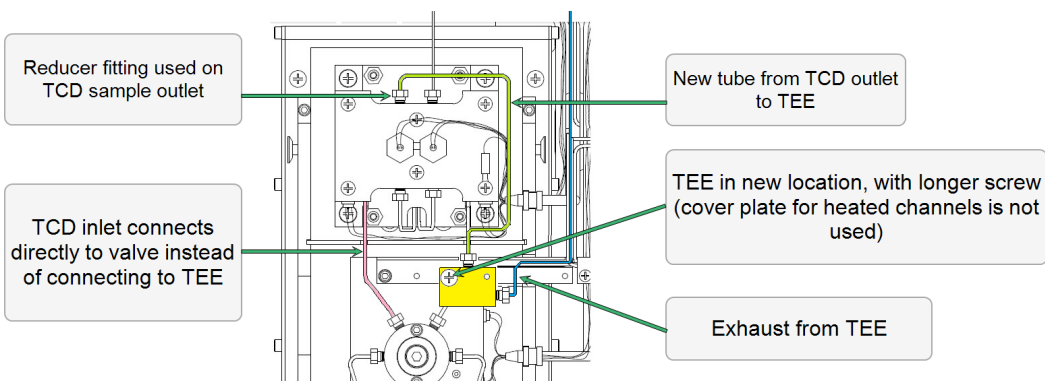

- Before attaching the TEE block to the heated path, install one of the two 10.5 in. long tubes (part number 004-03388-11, Hastelloy-C tubing 1/16 in. diameter × 10.5 in. long) from the center of the TEE to the exhaust port of the sample side of the TCD.



Note the orientation of the TEE. It will be installed “upside down” so that the counterbore for the original screw head is facing down.

10. Using a 1/8 in. to 1/16 in. reducer fitting, connect the other end of this tube to the exhaust of the TCD.
11. Install the 31 in. long tube (part number 004-03388-16, Hastelloy-C tubing 1/16 in. diameter × 31 in. long) from the right side of the TEE to the hexagonal fitting located above the exhaust ports where the 1/8 in. tube was removed.



A 1/8 in. to 1/16 in. reducer fitting is required.

12. Using the new screw (part number 004-28310-01, 6-32 × 1.5 Pan Head Phillips), attach the TEE as shown in the previous illustration.
13. Attach the new reducing union to the end of the Mass Spectrometer heated hose fitting. Use the ferrules included with the reducing fitting.

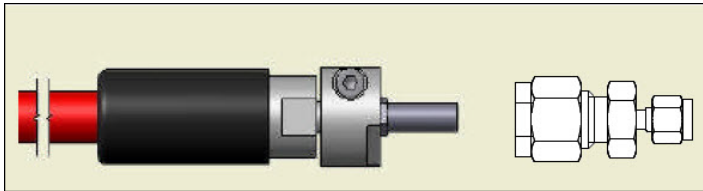

Mass Spec heated
capillary hose

Reducing fitting (1/4 in.
to 1/16 in.)

14. Pass the Mass Spectrometer hose through the side panel cover plate. The black plastic clamps above and below the Mass Spectrometer hose can be adjusted to prevent the Mass Spectrometer hose from being pulled out of the heated zone. The insulation rings may be used to prevent damage to the Mass Spectrometer hose insulation.
15. Re-attach the side panel cover plate, with the Mass Spectrometer hose passing through into the heated zone.

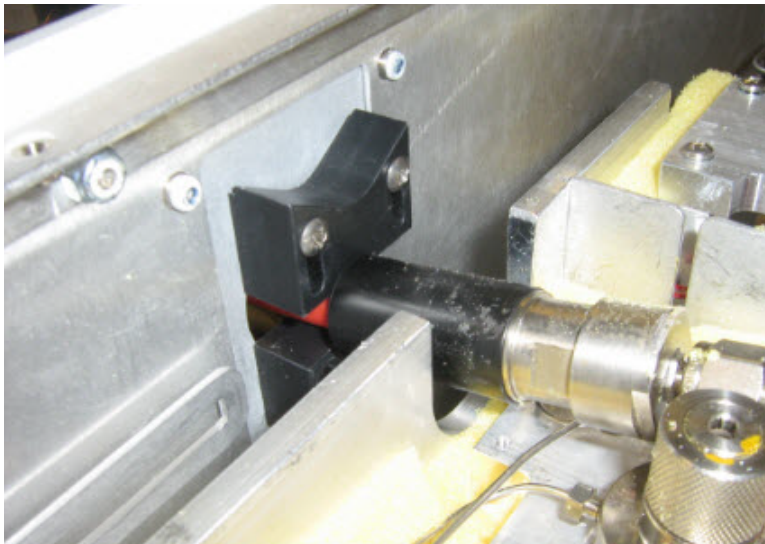

16. Install the other 10.5 in. long tube (part number 004-03388-11, Hastelloy-C tubing 1/16 in. diameter × 10.5 in. long) from the end of the Mass Spectrometer heated hose assembly (at the 1/16 in. end of the reducing fitting) to the left side port of the TEE. Nuts and ferrules are included in the kit. The tube must be bent so that the metal connectors of the Mass Spectrometer hose are inside the heated zone.

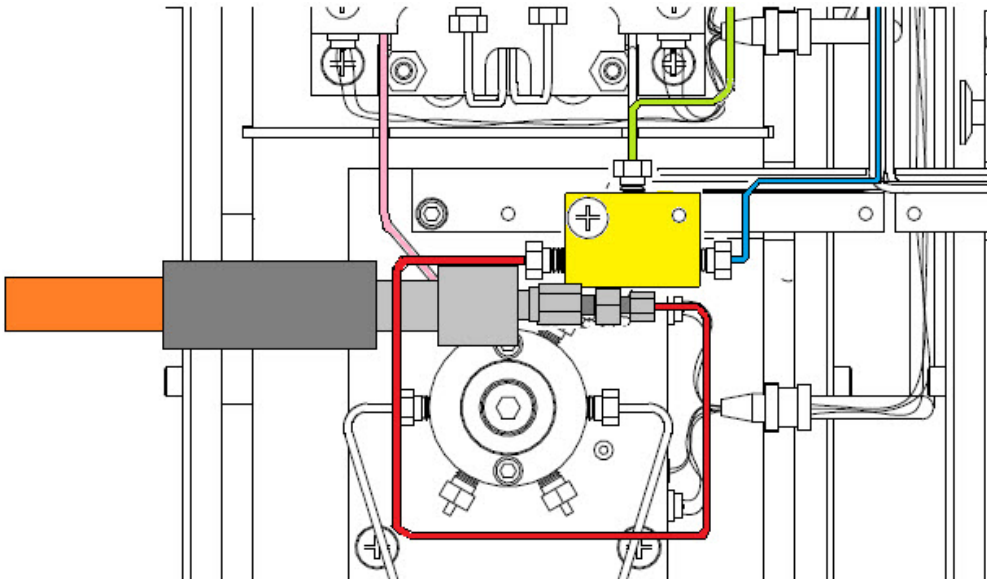

The plumbing should now resemble these photos:

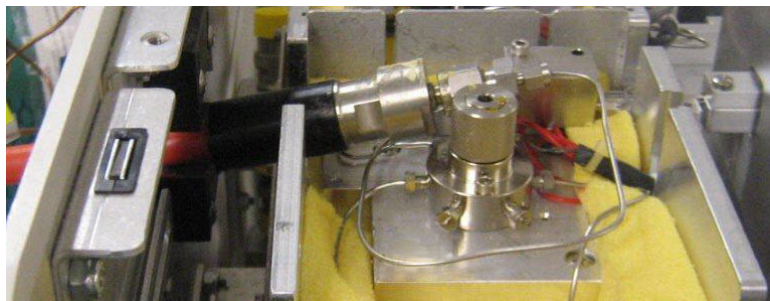

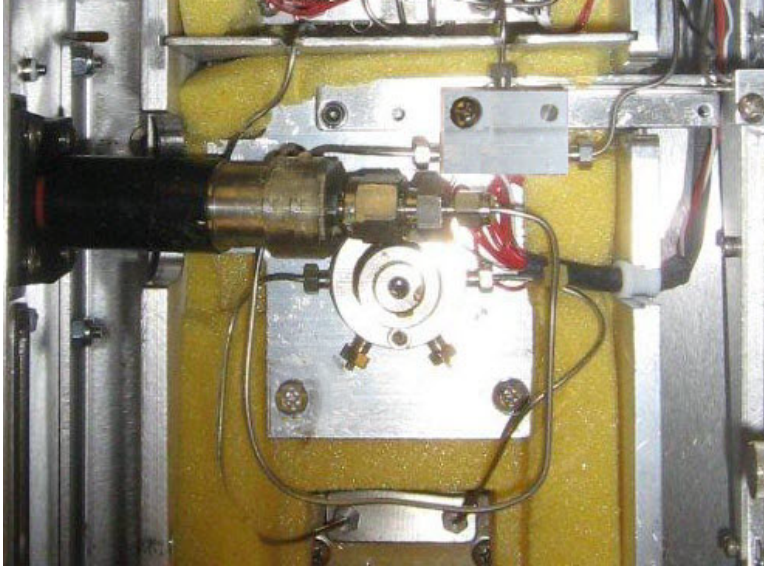

17. Replace the yellow foam insulation and the metal box covering the zone. The insulation may be cut to fit around the Mass Spectrometer hose.
18. Reset the heat zones to the preferred temperatures. Set the *Cold Trap Valve* heat zone to the proper temperature to ensure that the connection between the Mass Spectrometer end fitting is heated, even though it is not directly clamped to the heated plates.



See [Connect Cables on page 20](#) for instructions on connecting the cables from the Mass Spectrometer to the analyzer.

AUTOCHEM 2920 (SERIAL NUMBERS 701 AND ABOVE)

REQUIRED TOOLS

- Phillips head screwdriver
- 1/4 in. open-end wrench
- 3/8 in. open-end wrench
- 5/16 in. open-end wrench
- 7/16 in. open-end wrench
- 9/16 in. open-end wrench

The Mass Spectrometer connector is located on the side panel of the analyzer.

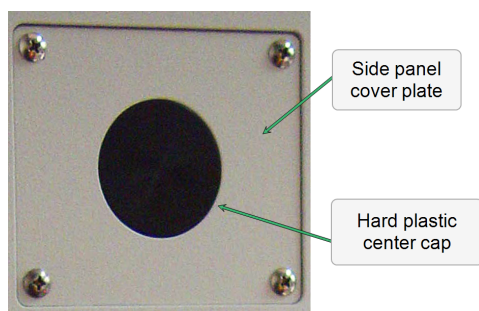

The cold trap valve zone of the AutoChem must be cool to allow safe handling of components. If necessary, allow a few hours for the zone to cool down after setting the zone to 20 °C. Removing the cover and insulation at the zone will speed the cooling process.

1. Open the top panel of the analyzer to allow access to the plumbing.
2. Loosen the screws that retain the plastic hose clamps, remove the side panel cover plate, and remove the hard plastic center cap shown in the following illustration. Save the screws for later.

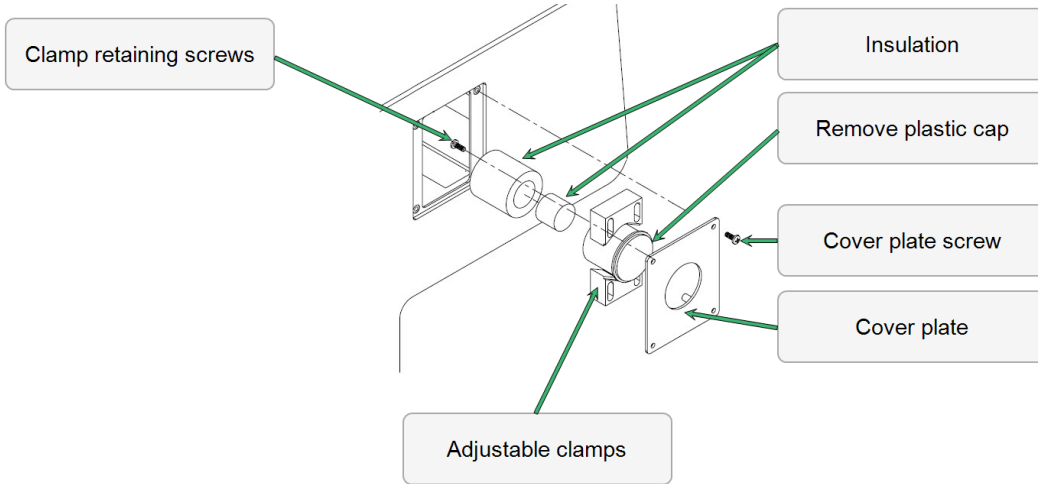

The 1/16 in. tubes are longer than required. **DO NOT CUT THE TUBES.** The tubing has been cut, deburred and cleaned. Further cutting will introduce small particles which can cause problems. If the tube is too long, either coil or zig-zag the tube to use the excess length.

With the covers and insulation removed, the Mass Spectrometer TEE connection block may be accessed.

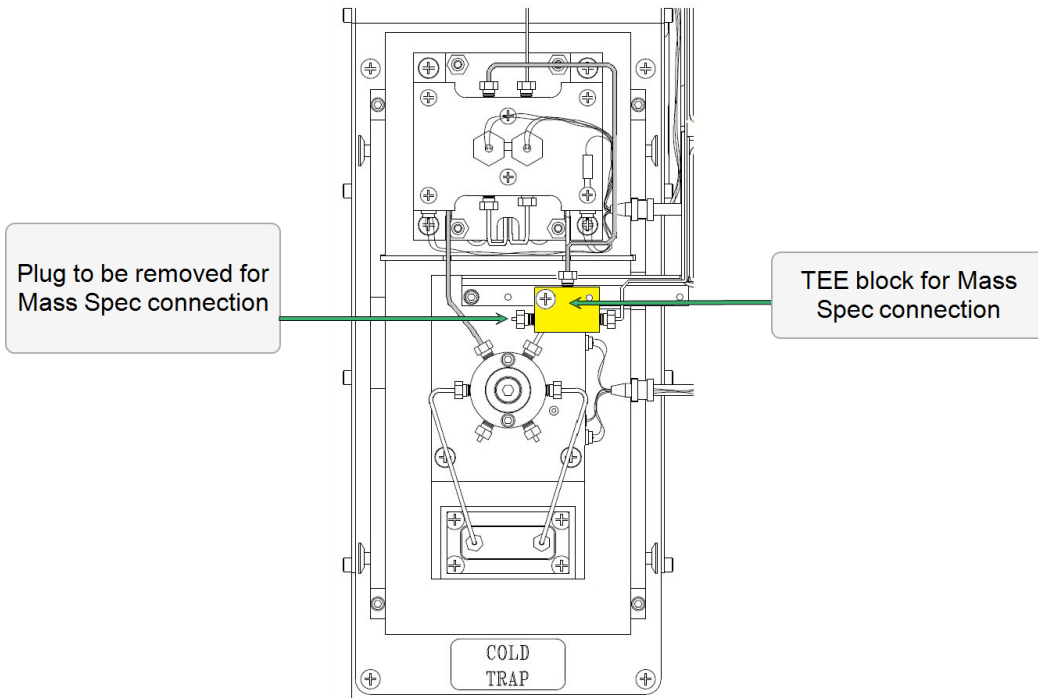

3. Remove the plug from the left side of the TEE.

- Attach the new reducing union to the end of the Mass Spectrometer heated hose fitting. Use the ferrules included with the reducing fitting.

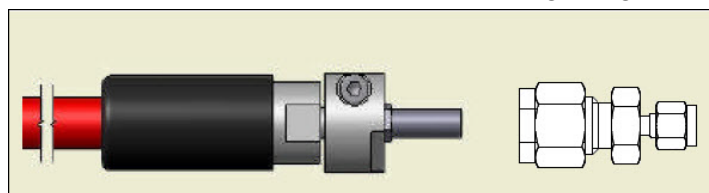

Mass Spec heated
capillary hose

Reducing fitting (1/4 in.
to 1/16 in.)

- Pass the Mass Spectrometer hose through the side panel cover plate. The black plastic clamps above and below the Mass Spectrometer hose can be adjusted to prevent the Mass Spectrometer hose from being pulled out of the heated zone. The insulation rings may be used to prevent damage to the Mass Spectrometer hose insulation.
- Re-attach the side panel cover plate, with the Mass Spectrometer hose passing through into the heated zone.

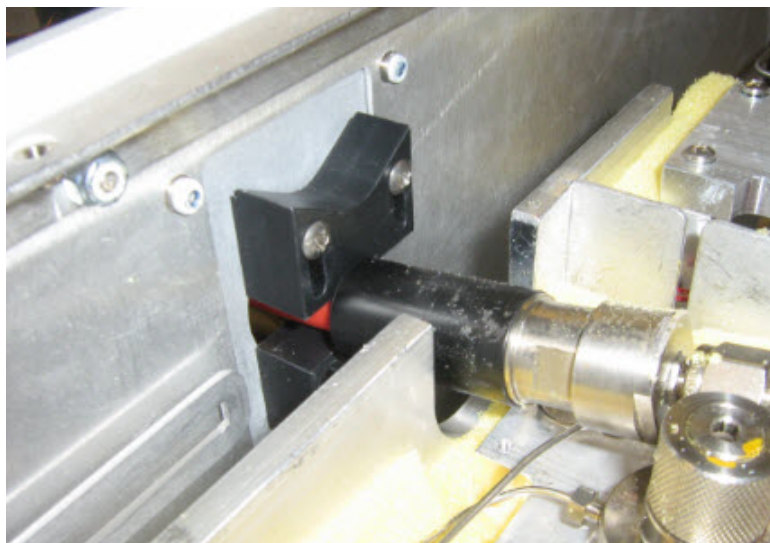

- Install one 10.5 in. long tube (part number 004-03388-11, Hastelloy-C tubing 1/16 in. diameter × 10.5 in. long) from the end of the Mass Spectrometer heated hose assembly (at the 1/16 in. end of the reducing fitting) to the left side port of the TEE. Nuts and ferrules are included in the kit. The tube must be bent so that the metal connectors of the Mass Spectrometer hose are inside the heated zone.

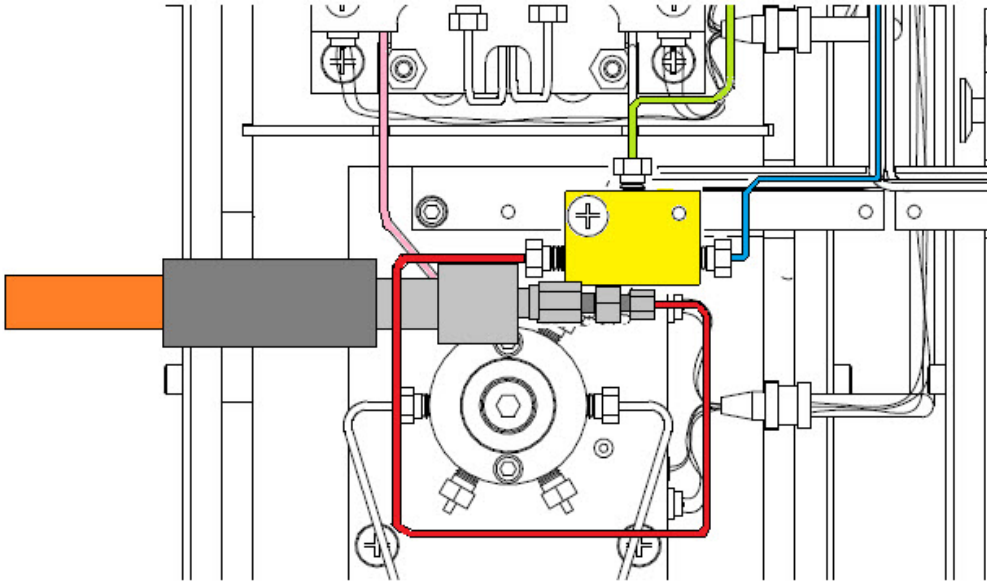

The plumbing should now resemble these photos:

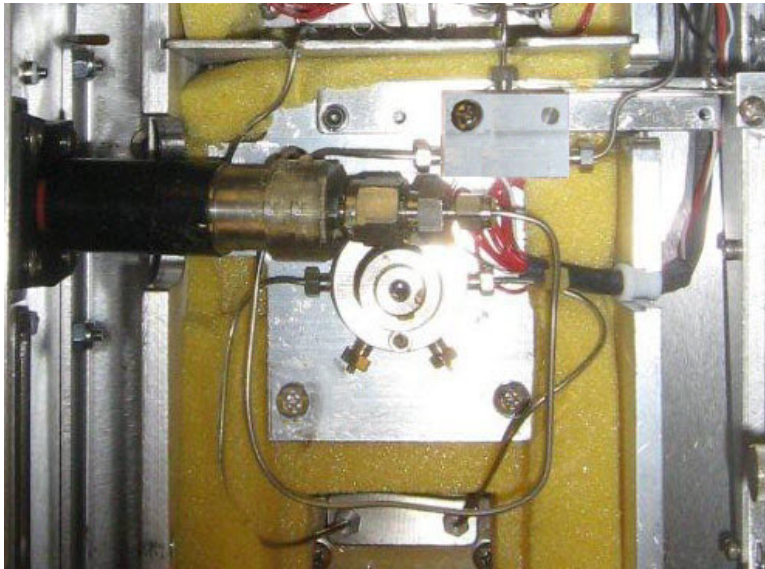
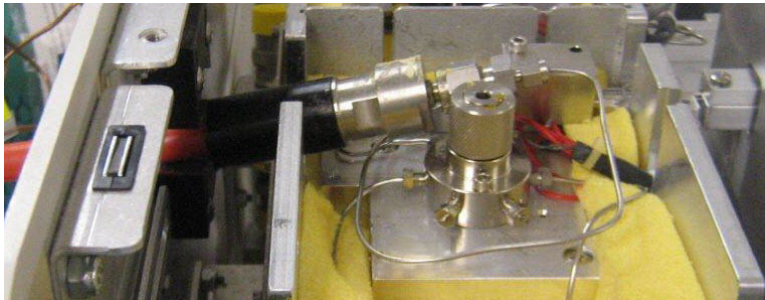

8. Replace the yellow foam insulation and the metal box covering the zone. The insulation may be cut to fit around the Mass Spectrometer hose.
9. Reset the heat zones to the preferred temperatures. Set the *Cold Trap Valve* heat zone to the proper temperature to ensure that the connection between the Mass Spectrometer end fitting is heated, even though it is not directly clamped to the heated plates.



See [Connect Cables on page 20](#) for instructions on connecting the cables from the Mass Spectrometer to the analyzer.

AUTOCHEM HP 2950

REQUIRED TOOLS

- Phillips head screwdriver
- 1/4 in. open-end wrench
- 5/16 in. wrench
- 9/16 in. open-end wrench

The Mass Spectrometer connector is located on the side panel of the analyzer.

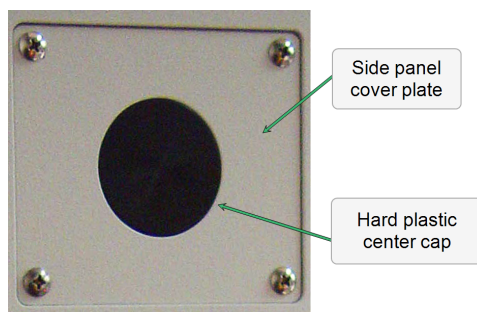

1. Remove the top cover panel and the upper rear panel of the analyzer.
2. Locate the Mass Spectrometer connection TEE block. It is mounted to a bracket behind a cover plate on the upper rear of the left side panel. There are two types of bracket, depending upon the serial number of the analyzer.

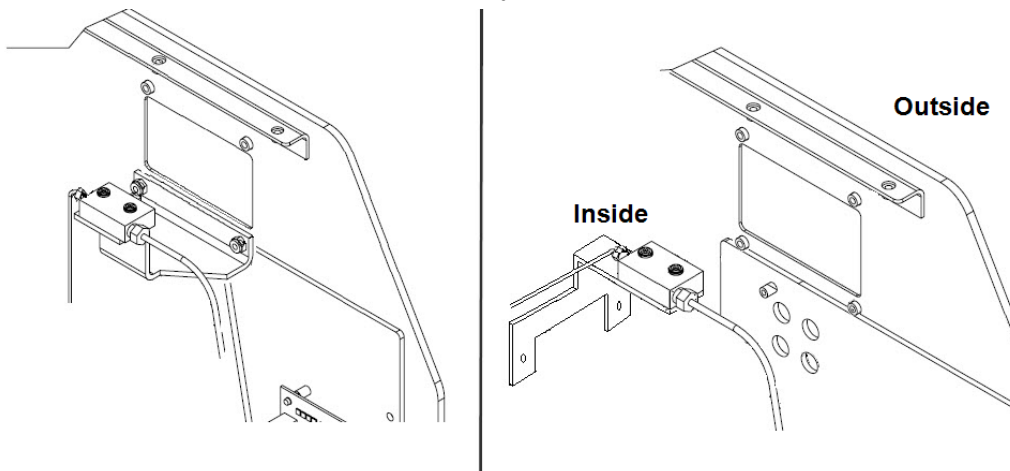

3. For serial numbers below 200, remove the two nuts which hold the Mass Spectrometer bracket to the side panel. Save the nuts for later.
4. Remove the side panel cover plate. Discard the insulation rings and the cover plate. Save the screws for later.

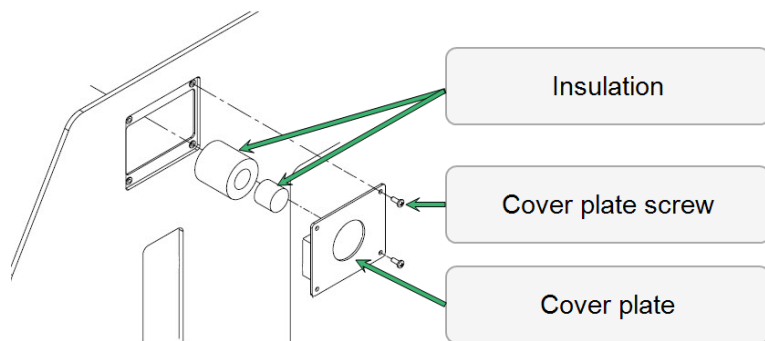

5. Remove the plug from the Mass Spectrometer TEE block.
6. Place a 1/16 in. swaging nut and ferrule onto the Mass Spectrometer port tube (from the parts and accessories kit) and insert the tube into the TEE block. Ensure that the tube is fully seated. Use 1/4 in. wrench to tighten the swaging nut.

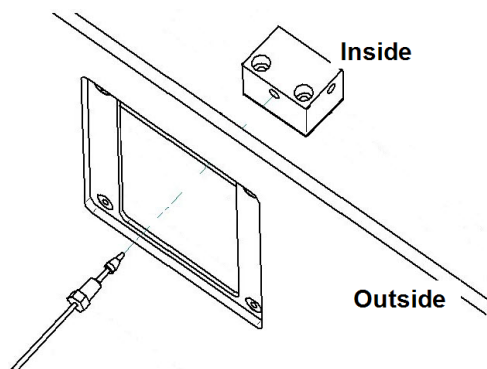

7. Mount the retaining ring onto the threaded stud located on the rear of the Mass Spectrometer port plate. Secure with the locking nut (part number 004-28205-00, nylon locking nut, 6-32). Do not tighten the nut completely.

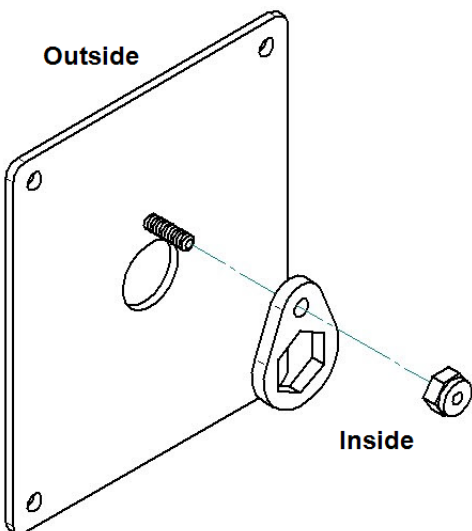

8. Attach the new port plate to the instrument using the screws saved from an earlier step.

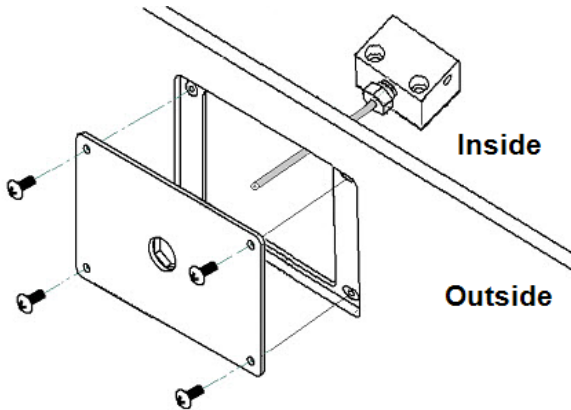

9. For instruments below serial number 200, re-attach the Mass Spectrometer TEE bracket to the side panel using the nuts previously saved.
10. Insert the 1/4 in. to 1/16 in. tube reducing union into the port plate and onto the port tube. Ensure all are aligned, then complete the tightening of the nylon locking nut on the retaining ring.

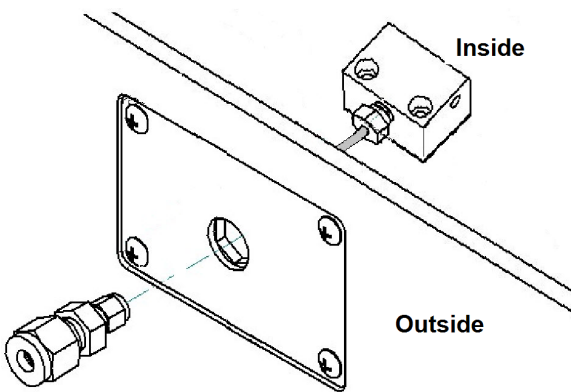

11. Use a 5/16 in. wrench to tighten the reducing union onto the port tube. The ferrules are already installed inside the reducing union.
12. Insert the 1/4 in. tube at the end of the Mass Spectrometer hose into the reducing union.

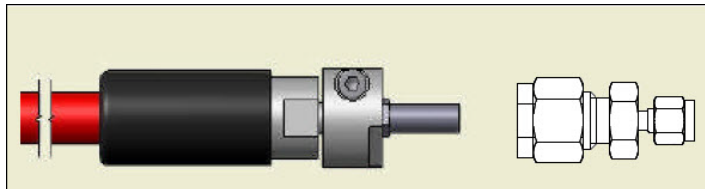

Mass Spec heated
capillary hose

Reducing fitting (1/4 in.
to 1/16 in.)

13. Use a 9/16 in. wrench to tighten the nut on the reducing union.
14. Re-install the rear panel and the analyzer top panel.



See [Connect Cables on page 20](#) for instructions on connecting the cables from the Mass Spectrometer to the analyzer.

3FLEX 3500 CHEMISORPTION

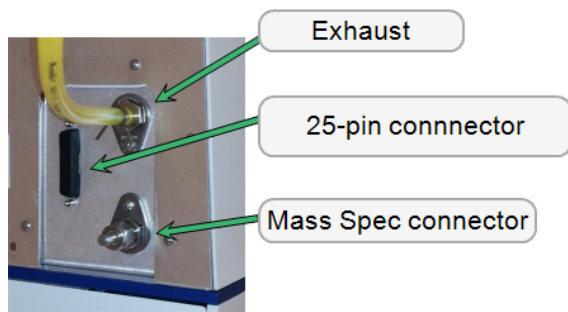

1. Remove the plug attached to the Mass Spectrometer connector port (1/4 in. Swagelok fitting on the back of the analyzer).



The Mass Spectrometer connector port and the exhaust port are interchangeable on the 3Flex 3500 Chemisorption analyzer.

2. Connect the Mass Spectrometer hose to the Mass Spectrometer connector port on the back of the analyzer, using the ferrules from the *MKS Cirrus to 3Flex Accessories Kit* (part number 350-33031-00) and the 9/16 in. nut to secure the connection.



See [Connect Cables on page 20](#) for instructions on connecting the cables from the Mass Spectrometer to the analyzer.

ASAP 2020 CHEMISORPTION

1. Assemble the 316 stainless steel tubing with the reducing union on one end and the swaging nut and ferrule on the other.

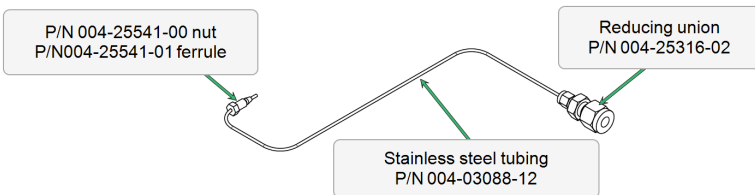

2. Remove the 1/16 in. plug from the analyzer.

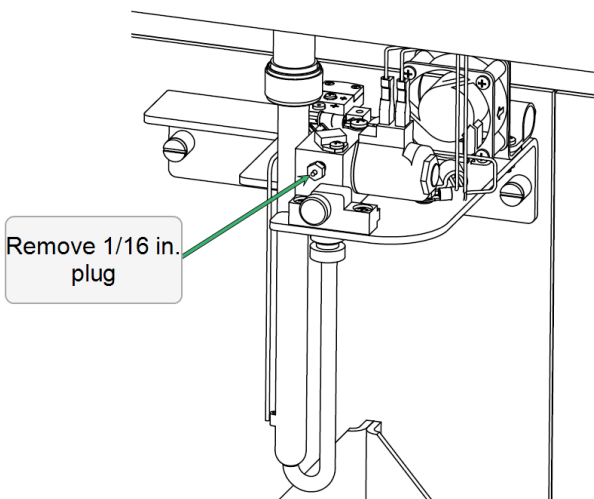

3. Insert the ferrule into the opening where the 1/16 plug was removed.

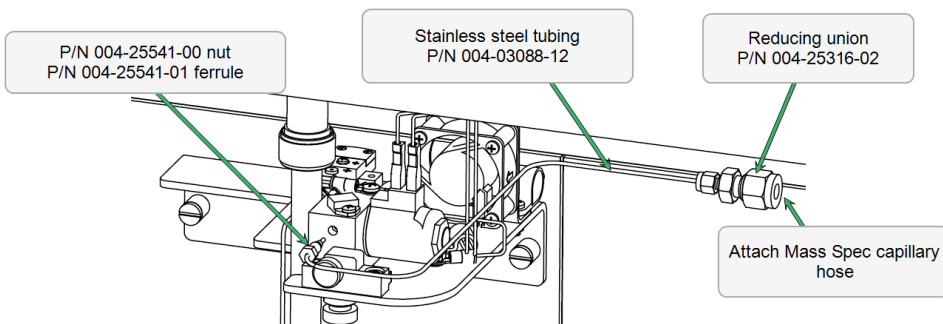

4. Bend the stainless steel tubing so that it does not interfere with the operation of the analyzer.
5. Insert the Mass Spectrometer capillary hose fitting into the reducing union on the stainless steel tube.

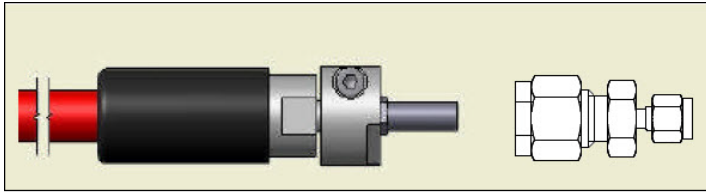

Mass Spec heated
capillary hose

Reducing fitting (1/4 in.
to 1/16 in.)

6. Use a 9/16 in. wrench to tighten the nut on the reducing union.



See [Connect Cables on the next page](#) for instructions on connecting the cables from the Mass Spectrometer to the analyzer.

CONNECT CABLES

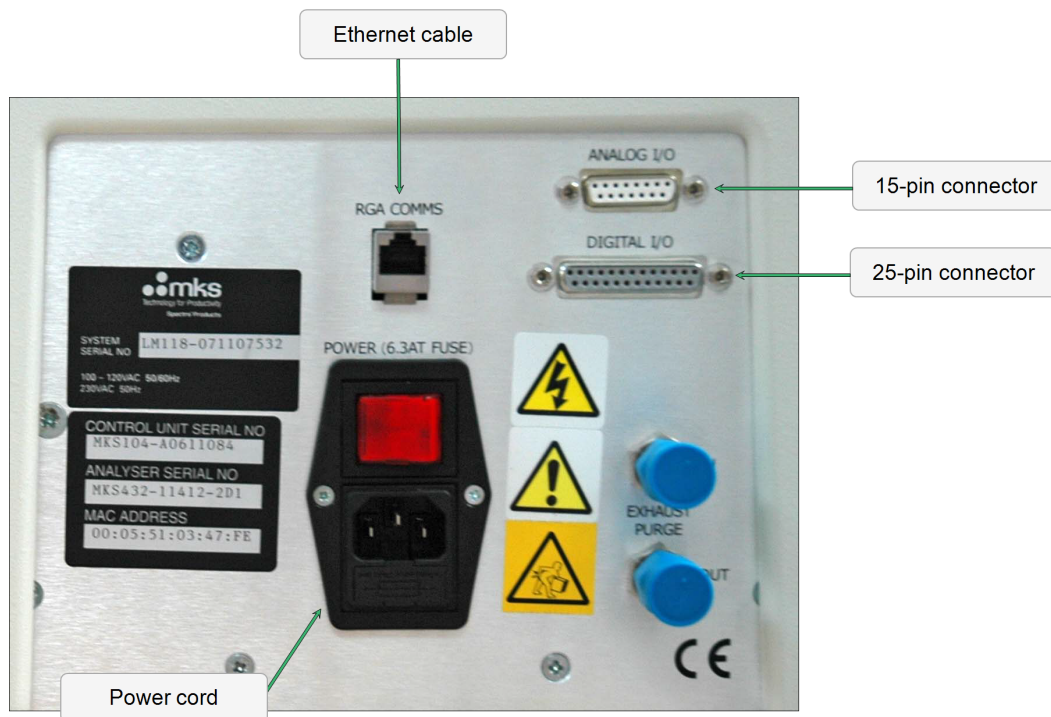

Mass Spectrometer Interface Panel

MASS SPECTROMETER TO AUTOCHEM ANALYZERS

1. Plug one end of the power cord into the connector on the rear panel of the Mass Spectrometer and the other end into an appropriate power source. Refer to the *Cirrus 2 Hardware Manual* for electrical specifications.
2. Connect one end of a standard Ethernet cable to the RGA COMMS port on the rear panel of the Mass Spectrometer and the other end to an Ethernet port on the computer.



The Analog/Digital I/O interface cable is comprised of two cables tethered together: one cable has a 15-pin connector (for the Analog I/O connection) and the other a 25-pin connector (for the Digital I/O connection).

3. On the rear panel of the Mass Spectrometer, attach the 15-pin and 25-pin connectors labeled *Cirrus* to their appropriate connections. Tighten the retaining screws.
4. On the side panel of the AutoChem, attach the 15-pin and 25-pin connectors labeled *AutoChem* to their appropriate connections. Tighten the retaining screws.

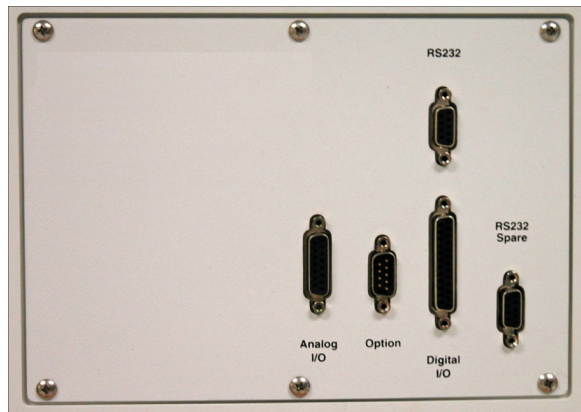

MASS SPECTROMETER TO 3FLEX 3500 CHEMISORPTION ANALYZER

1. Plug one end of the power cord into the connector on the rear panel of the Mass Spectrometer and the other end into an appropriate power source. Refer to the *Cirrus 2 Hardware Manual* for electrical specifications.
2. On the rear panel of the Mass Spectrometer, attach the 25-pin connector of the straight-thru cable to its appropriate connection. Tighten the retaining screws.
3. On the back panel of the analyzer, attach the 25-pin connector of the straight-thru cable to its appropriate connection. Tighten the retaining screws.

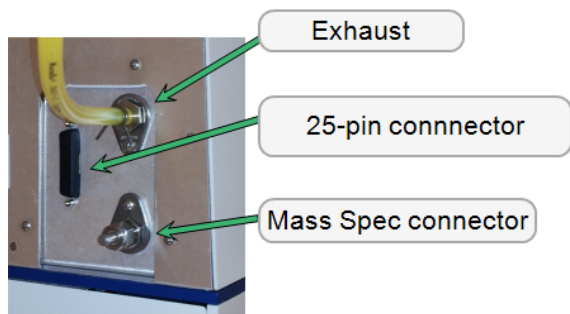

MASS SPECTROMETER TO ASAP 2020 CHEMISORPTION ANALYZER

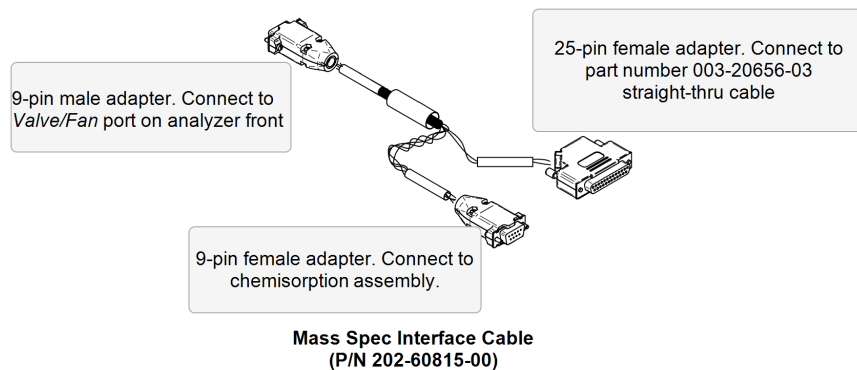

1. Disconnect the 9-pin connector from the *Valve/Fan* port on the front of the analyzer.
2. Connect and tighten the 9-pin female connector on the interface cable to the 9-pin male connector disconnected in the previous step.

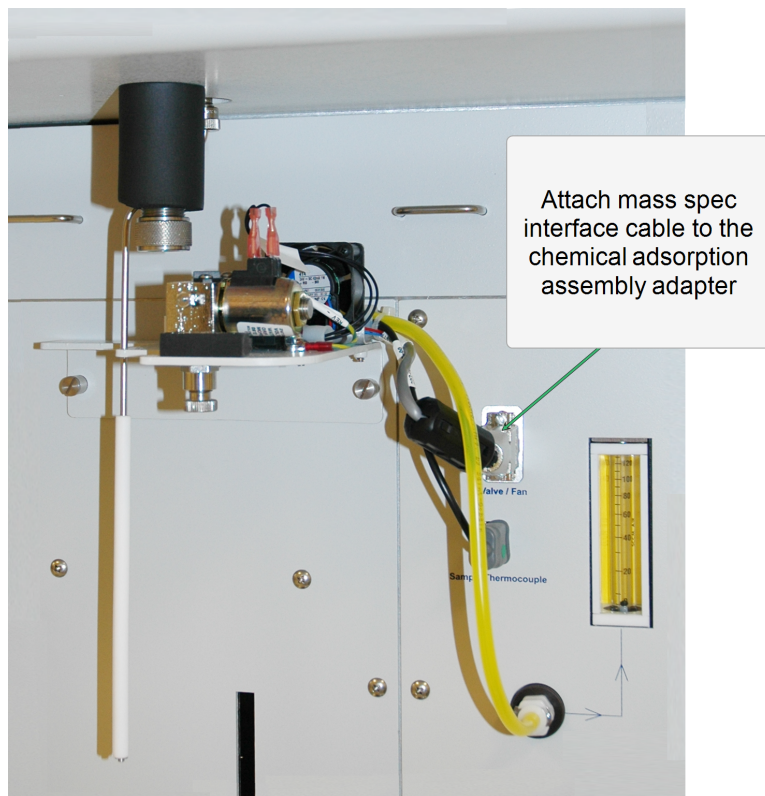

3. Connect and tighten the 9-pin male connector to the *Valve/Fan* port on the analyzer front.
4. Connect and tighten the extension cable (P/N 003-20656-03) to the 25-pin connector on the interface cable (P/N 202-60815-00).

5. On the rear panel of the Mass Spectrometer, attach the 25-pin male connector of the straight-thru cable. Tighten the retaining screws.
6. Plug one end of the power cord into the connector on the rear panel of the Mass Spectrometer and the other end into an appropriate power source. Refer to the *Cirrus 2 Hardware Manual* for electrical specifications.

PIN-OUTS FOR MASS SPEC CONNECTORS

AUTOCHEM 2920 AND AUTOCHEM 2950 ANALYZERS

Analog

The 15-pin analog connector provides two output signals and two input signals.

Output signals:

- The TCD signal (could be as high as 12 volts —positive or negative)
- The sample temperature signal, which is a buffered voltage from the sample thermocouple. The voltage ranges from -0.365 V at $-40\text{ }^{\circ}\text{C}$; 0 at $0\text{ }^{\circ}\text{C}$; to 10.88 V at $110\text{ }^{\circ}\text{C}$. The signal follows the type-K thermocouple nonlinear characteristic.

The signals are available at these pins:

TCD (+) 7
TCD (–) 5
Temp (+) 8
Temp (–) 6

Input signals:

The inputs are available for connection to other detectors, such as a mass spectrometer. The voltage range is -15 to 15 volts. The analyzer application can record these signals at the same time as it records TCD and sample thermocouple data.

The signals connect to these pins:

Auxiliary input 1 (+) 4
Auxiliary input 1 (–) 3
Auxiliary input 2 (+) 2
Auxiliary input 2 (–) 1

All other pins in the 15-pin connector are floating (not connected). Connect the metal shell of the connector to the chassis ground and cable shield to maintain shielding of the signals.

Digital

The 25-pin digital connector provides floating signals to control and monitor external hardware — such as auxiliary detectors or chart recorders.

The outputs consist of four sets of latching relay contacts and four opto-coupled photo transistors. The inputs are two optically isolated photo couplers.

The analyzer application sets these as logic 1 or logic 0 — as defined by the analysis step. They are displayed on the analyzer schematic.

A logic 1 causes the relay to connect the *common* contact to the *normally open* contact. The relay will retain this condition even when power to the analyzer is disconnected. A logic 0 causes the relay to connect the *common* contact to the *normally closed* contact.

A logic 1 to the opto-coupled outputs causes the NPN photo transistor to be turned on. A logic 0 turns the NPN photo transistor off.

The two opto-coupled inputs are read by the instrument as logic 1 (when current flows through the opto-coupler photo diodes) or logic 0 (when no current is flowing).

Electrical Specifications

Relays	<ul style="list-style-type: none"> • Maximum voltage: 250 VAC, 48 VDC • Maximum switching current: 4A at 250 VAC; 3A at 30 VDC • Maximum switching current: 100 mA at 100 VDC
Opto-coupled outputs	<ul style="list-style-type: none"> • Maximum voltage, VCE = 70 VDC • Maximum reverse voltage, VCE = 7 VDC • Maximum current = 10 mA
Opto-coupled inputs	<ul style="list-style-type: none"> • Maximum reverse voltage = 3 v • Nominal forward voltage = 1.3 v at 10 mA • Minimum current required to be recognized by the 2950 analyzer = 1 mA

Digital Connector Pin Designations

Pin	Type	Function
1	Relay 1	normally closed
2	Relay 1	common
3	Relay 1	normally open
4	Relay 2	normally closed
5	Relay 2	common
6	Relay 2	normally open
7	Relay 3	normally closed
8	Relay 3	common
9	Relay 3	normally open
10	Relay 4	normally closed
11	Relay 4	normally open
12	Relay 4	normally open
13	Not Used	not used
14	Opto output 1	collector
15	Opto output 1	emitter
16	Opto output 2	collector
17	Opto output 2	emitter
18	Opto output 3	collector
19	Opto output 3	emitter
20	Opto output 4	collector
21	Opto output 4	emitter
22	Opto input 1	anode (+)
23	Opto input 1	cathode (-)
24	Opto input 2	anode (+)
25	Opto input 2	cathode (-)

ASAP 2020 PLUS CHEMICAL ADSORPTION ANALYZER

The cable from the chemisorption port has a 25-pin D connector with female contacts. It is designed to allow a 25-pin D cable with male connector pins on both ends to directly connect to a MKS Cirrus Mass Spectrometer.

Pin 6. Normally open contact of the 3Flex relay

Pin 10. The common pole of the 3Flex relay.

Other pins are not used.

3FLEX CHEMICAL ADSORPTION ANALYZER

The rear panel has a 25-pin D connector with female contacts. It is designed to allow a 25-pin D cable with male connector pins on both ends to directly connect to a MKS Cirrus Mass Spectrometer.

Pin 6. Normally open contact of the 3Flex relay

Pin 10. The common pole of the 3Flex relay.

Other pins are not used.

SOFTWARE INSTALLATION AND OPERATION PREPARATION



Ensure the MKS Cirrus Mass Spectrometer is powered on before installing the software so that the software can auto-detect the instrument. Powering on the MKS Cirrus Mass Spectrometer only allows communications between the instrument and software. See [Set Up and Prepare for Operation on page 32](#) to learn how to power on the MKS Cirrus Mass Spectrometer pumps and heaters.

Two software applications that must be installed for the Mass Spectrometer hardware to work effectively with specific Micromeritics analyzers:

Required Software Applications

Application Name	Description
Process Eye Professional	 <p>The MKS <i>Process Eye Professional</i> software must be installed prior to installation of the <i>Micromeritics Custom Recipe</i> disk.</p> <p>Use the installation disk labeled <i>RGA Software</i> to install the <i>Process Eye Professional</i> software. All supporting documentation is located on the <i>MKS User Manuals</i> disk.</p>
Micromeritics Custom Recipe disk	<p>After installation of the <i>Process Eye Professional</i> software, a user setup utility is used for installation of the <i>Micromeritics Custom Recipe</i> disk.</p>

MICROMERITICS CUSTOM RECIPE INSTALLATION

1. Insert the Micromeritics Custom Recipe installation media into the media drive.
2. Go to **Start > All Programs > MKS RGA Applications > Tools > User Setup**.
3. The *Setup Wizard* displays. Click **Next**.
4. On the *Install Recipes* window, click **Have Disk**.

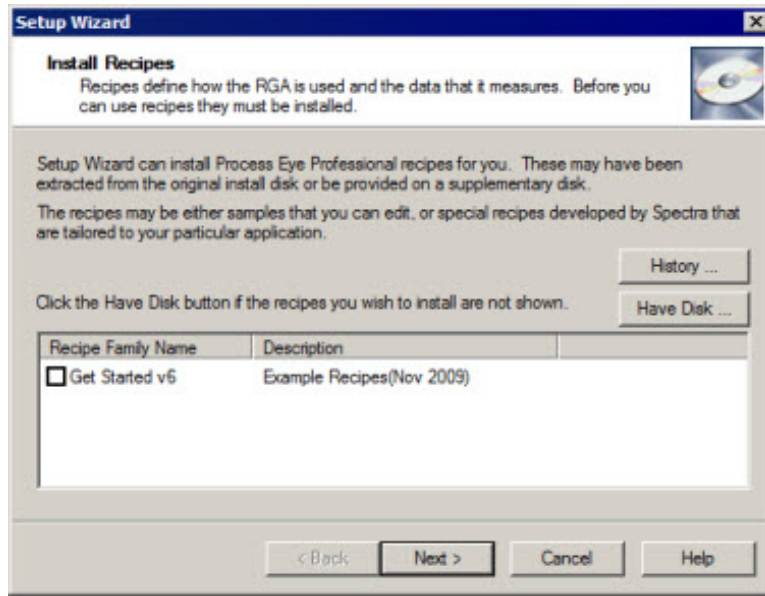

5. On the *Select a Drive Location* window, click the down arrow to the right of the text field, select **Browse**, then click **OK**.

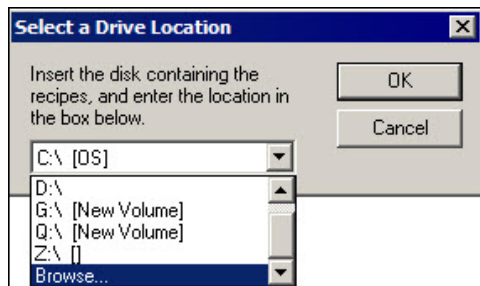

6. Navigate to the *Micromeritics/MKS/Software* directory on the installation disk. Select the *Micromeritics Install V[n].lst* file, then click **Open**.
7. The *Install Recipes* window displays the installed recipes. Select the *MKS* check box, then click **Next**.

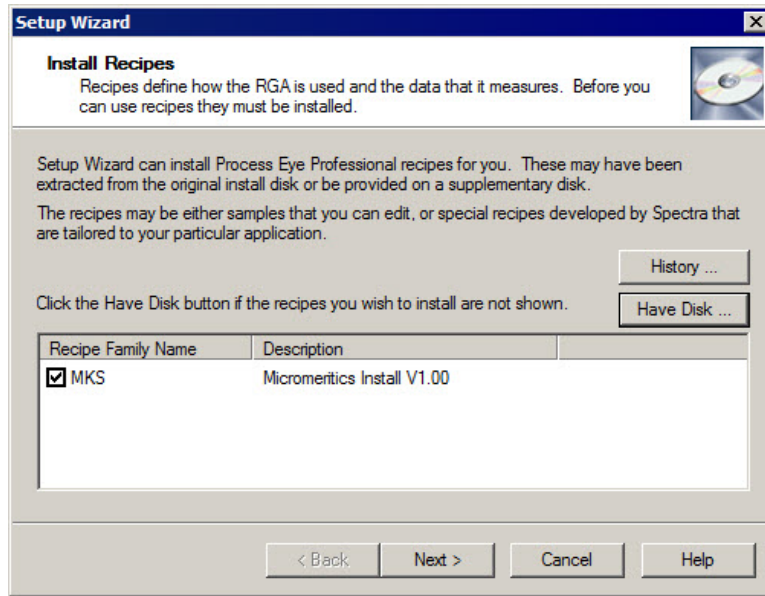

8. On the *Hardware Setup* window, ensure the *Skip Hardware Auto-Detection* option is selected, then click **Next**.
9. Verify the *Setup Wizard* has enough information to complete the installation, then click **Finish**.
10. On the *Recipe Installation History* window, click **Close**.

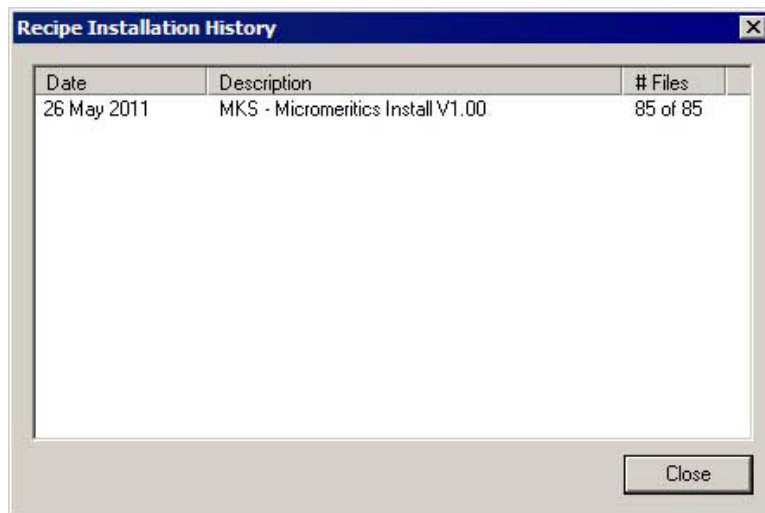

11. Go to **Start > All Programs > MKS RGA Applications > RGA Device Manager**.
12. On the *RGA Device Manager* window, locate your unit. Right click and select **Access**.

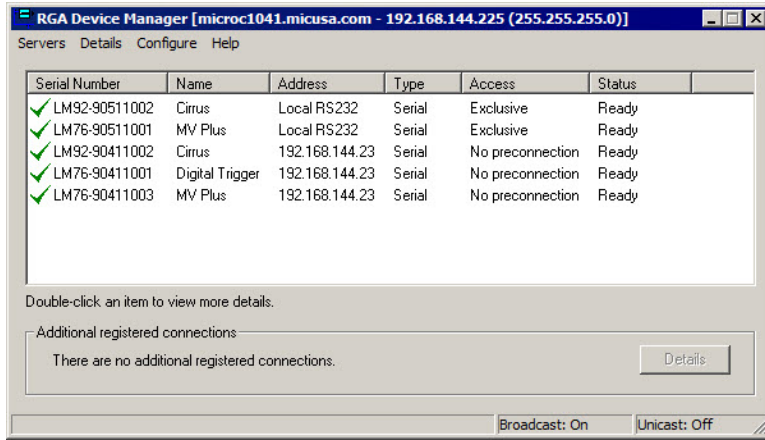

13. On the *Instrument Access* window, click **OK** to complete installation.
14. Go to **Start > All Programs > MKS RGA Applications > Process Eye Professional**.

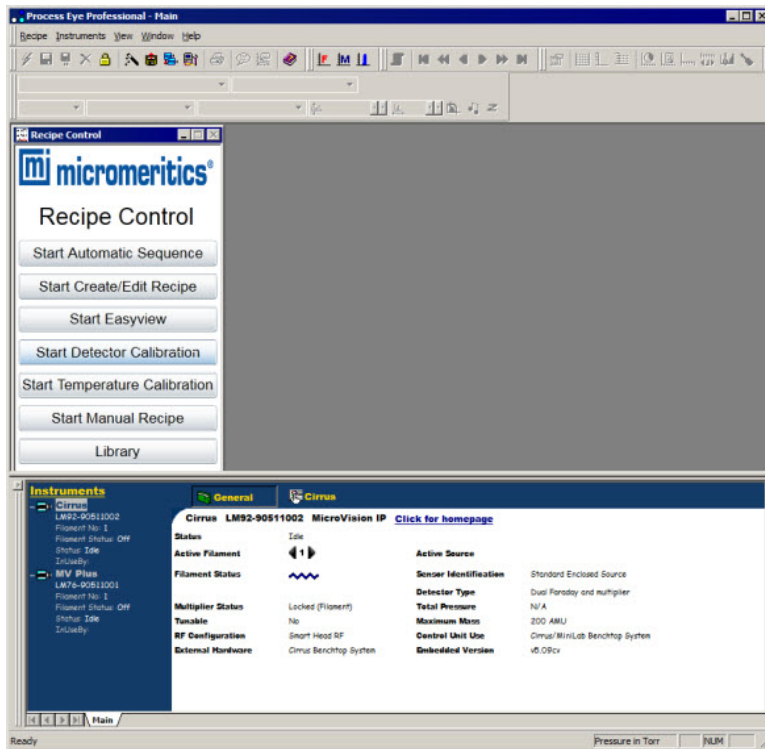



If a prompt displays to install *Microsoft Silverlight*, then *Microsoft Silverlight* is not installed. The *Process Eye Professional* application requires *Microsoft Silverlight* for operating the interface software.

To install from the Internet, click [Click now to install](#) to install the program. After installation is complete, press **F5** to display the *Recipe Control* menu.

To install from the Windows Explorer display, minimize the *Process Eye Professional* window, then navigate to *C:\Micromeritics\MKS\Microsoft Silverlight*. After installation is complete, maximize the *Process Eye Professional* window and press **F5** to display the *Recipe Control* menu.

SET UP AND PREPARE FOR OPERATION



The MKS Cirrus Mass Spectrometer pumps are powered on using the MKS *Process Eye Professional* software. Powering on the pumps (to allow them to get to full performance) and powering on the heaters should be done before using the MKS Cirrus Mass Spectrometer.

1. Click the *Cirrus* tab on the *Status* window to access and begin component operation.

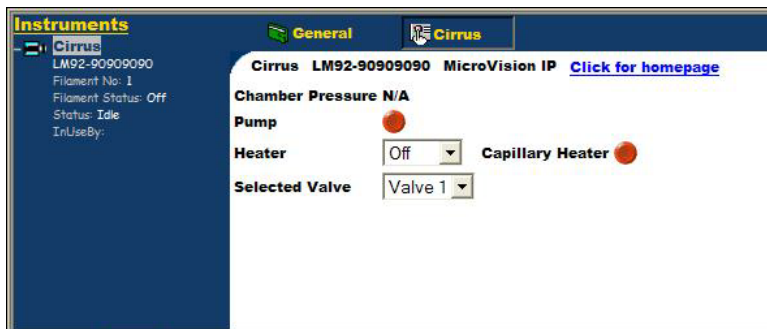

2. Use the instrument schematic to begin the flow of an inert gas (such as helium, argon, and nitrogen) to remove residual gases from the analyzer and for the next steps.
3. Click **Pump** to start the pump. The button changes to yellow to indicate that the internal molecular drag pump is accelerating. After the turbo is up to speed, the button will change to green and the chamber pressure will display.



To avoid damaging the pump, do not move the unit after the turbo pump has begun operating.

The pressure should be less than $2E-5$ Torr before switching on a filament or the quadrupole. The trip contact on the cold cathode gauge is connected to the external trip on the RGA control unit to prevent filament operation until the pressure falls below this level. This level should be attained within 20 minutes after starting the vacuum system.

4. Use the *Warm/Bake* options in the *Heater* drop-down list. Do not operate the secondary electron multiplier (SEM) detector with the *Bake* option.



Before the system can be started properly, it will need to run a sufficient amount of time to allow the partial pressure peaks of moisture and other airborne gasses to drop to an acceptable level. This time can be significantly reduced by baking the system. This should be done after the system has run for at least an hour to allow the pressure in the system to drop below $2E-5$ Torr. The gas flow rate should be at least 20 sccm.

A dry, inert gas should be flushed continuously through the capillary inlet during bake out. The quadrupole should be running with the filament on but only using the Faraday detector. The multiplier detector will be unavailable during baking.

The total pressure may gradually start to rise during the *Bake* cycle as the system outgases; bake the system until the pressure starts to fall. In normal operation, an initial bake of at least 24 hours is recommended, although, in general, the longer the system is baked the better. If the Cirrus is powered off, it will vent to atmosphere introducing water vapor and should be baked again.

The *Warm/Bake* option should be set to *Bake* for the initial bake-out to reduce the water background. After this period, running at the lower temperature of *Warm* is adequate in preventing the condensation of vapors in the vacuum chamber which could lead to memory effects.

Often it is not necessary to have the system heater on at all, but this will depend on the application. The Cirrus is designed to allow continuous operation with the system heater set to *Warm*.

Refer to the Cirrus 2 Hardware manual for additional information on the *Warm/Bake* option.

5. Use the *Capillary Heater* to lessen the chance of vapor condensing in the capillary leading to memory effects or blockage. Whether or not the capillary needs to be heated depends on the application and the nature of the gases being sampled. The Cirrus is designed to allow the capillary heater to be run continuously.

POWER OFF THE MASS SPECTROMETER

The Mass Spectrometer should be allowed to run continuously unless it will not be used for an extended period of time or needs to be powered down for maintenance.

1. Power OFF the capillary and system heaters.
2. Power OFF the filaments.



3. Wait 10 minutes to allow the filaments to cool.
4. Click the **Pump** button to stop the turbo. The pumps will stop and the vent valve will open after a few minutes.
5. Wait 5 minutes for the system to cool further and come to a full stop.

PARTS AND ACCESSORIES

Order system components and accessories using one of the following methods:

- Call our Customer Service Department at 1-770-662-3636
- Email orders to Orders@Micromeritics.com
- Contact your local sales representative



The parts kit for the AutoChem 2920 has extra parts, depending upon the serial number of the instrument.

AUTOCHEM 2920 KIT, (P/N 292-33014-00)

Part Number	Item and Description
004-03388-11	Hastelloy-C tubing 1/16 in. diameter × 10.5 in. long (qty. 2)
004-03388-16	Hastelloy-C tubing 1/16 in. diameter × 31 in. long
004-25316-02	Reducing union, 1/4 in. tube to 1/16 in. tube
004-25541-00	Swaging nut, 1/16 in. Valco (qty. 4)
004-25541-11	Ferrule, 1/16 in. Hastelloy-C (qty. 4)
004-25587-10	Reducer Fitting, 1/8 to 1/16 Hastelloy-C (qty. 2)
004-28310-01	Screw, 6-32 × 1.5 pan head Phillips, stainless steel
004-54113-00	Wrench, 7/64 Allen, for 6-32 socket head screws
292-20805-00	Software, MKS Cirrus Mass Spectrometer
292-42804-00	Micro-Cirrus Interface User Guide
292-42805-00	Micro-Cirrus Interface Installation Instructions
292-60805-00	Cable, Mass Spectrometer

AUTOCHEM HP 2950 KIT, (P/N 295-33002-00)

Part Number	Item and Description
004-25201-00	Bulkhead fitting retainer
004-25316-02	Reducing union, 1/4 in. tube to 1/16 in. tube
004-25541-00	Swaging nut, 1/16 in. Valco
004-25541-01	Ferrule, 1/16 in.
004-28205-00	Nylon locking nut, 6-32
292-14817-00	Port plate, Mass Spectrometer
292-20805-00	Software, MKS Cirrus Mass Spectrometer
292-42804-00	Micro-Cirrus Interface User Guide
292-42805-00	Micro-Cirrus Interface Installation Instructions
292-60805-00	Cable, Mass Spectrometer
295-25830-00	Port tube, Mass Spectrometer

3FLEX 3500 KIT, (P/N 350-33031-00)

Part Number	Item and Description
003-20656-03	Cable, M/M 25 Pin D 5FT Straight Thru
004-25104-00	Ferrule, Rear, 1/4 in. Nylon (qty. 2)
004-25139-00	Ferrule, Front, 1/4 in. Peek (qty. 2)
292-20805-00	Software, MKS Cirrus Mass Spectrometer
292-42804-00	Micro-Cirrus Interface User Guide
292-42805-00	Micro-Cirrus Interface Installation Instructions

ASAP 2020 PLUS KIT, (P/N 202-33005-00)

Part Number	Item and Description
003-20656-03	25 pin D M/M straight-thru to connect 202-60815-00 interface adapter cable to Mass Spec
004-03088-12	Stainless steel tubing 316 — 1/16 OD x .040 ID x 18 in.long
004-25316-02	Union, reducing, 1/4 in. tube to 1/16 in. tube
004-25541-00	Swaging nut, 1/16 in.
004-25541-01	Ferrule, 1/16-in.
202-60815-00	Cable, chemisorption port to mass spectrometer interface
292-20805-00	Software, MKS Cirrus Mass Spectrometer
292-42804-00	Micro-Cirrus Interface User Guide
292-42805-00	Micro-Cirrus Interface Installation Instructions