



SediGraph III Plus

Operator Manual

Rev C

SediSperse is a registered trademark of Micromeritics Instrument Corporation
Ertalyte is a registered trademark of Quadrant Engineering Plastic Products
Kalrez and Viton are registered trademarks of DuPont Dow Elastomers L.L.C.
Tygon is a registered trademark of Norton Company
Teflon is a registered trademark of E.I. DuPont de Nemours Company
Windows is a registered trademark of Microsoft Corporation

WARRANTY

MICROMERITICS INSTRUMENT CORPORATION warrants for one year from the date of shipment each instrument manufactured by it to be free from defects in material and workmanship impairing its usefulness under normal use and service conditions except as noted herein.

Our liability under this warranty is limited to repair, servicing and adjustment, free of charge at our plant, of any instrument or defective parts, when returned prepaid to us, and which our examination discloses to have been defective. The purchaser is responsible for all transportation charges involving the shipment of materials for warranty repairs. Failure of any instrument or product due to operator error, improper installation, unauthorized repair or alteration, failure of utilities, or environmental contamination will not constitute a warranty claim. The materials of construction used in MICROMERITICS instruments and other products were chosen after extensive testing and experience for their reliability and durability. However, these materials cannot be totally guaranteed against wear and / or decomposition by chemical action (corrosion) as a result of normal use.

Repair parts are warranted to be free from defects in material and workmanship for 90 days from the date of shipment.

No instrument or product shall be returned to MICROMERITICS prior to notification of alleged defect and authorization to return the instrument or product. All repairs or replacements are made subject to factory inspection of returned parts.

MICROMERITICS shall be released from all obligations under its warranty in the event repairs or modifications are made by persons other than its own authorized service personnel unless such work is authorized in writing by MICROMERITICS.

The obligations of this warranty will be limited under the following conditions:

1. Certain products sold by MICROMERITICS are the products of reputable manufacturers, sold under their respective brand names or trade names. We, therefore, make no express or implied warranty as to such products. We shall use our best efforts to obtain from the manufacturer, in accordance with his customary practice, the repair or replacement of such of his products that may prove defective in workmanship or materials. Service charges made by such manufacturer are the responsibility of the ultimate purchaser. This states our entire liability in respect to such products, except as an authorized person of MICROMERITICS may otherwise agree to in writing.
2. If an instrument or product is found defective during the warranty period, replacement parts may, at the discretion of MICROMERITICS, be sent to be installed by the purchaser, e.g., printed circuit boards, check valves, seals, etc.
3. Expendable items, e.g., sample tubes, detector source lamps, indicator lamps, fuses, valve plugs (rotor) and stems, seals and O-rings, ferrules, etc., are excluded from this warranty except for manufacturing defects. Such items which perform satisfactorily during the first 45 days after the date of shipment are assumed to be free of manufacturing defects.

Purchaser agrees to hold MICROMERITICS harmless from any patent infringement action brought against MICROMERITICS if, at the request of the purchaser, MICROMERITICS modifies a standard product or manufactures a special product to the purchaser's specifications.

MICROMERITICS shall not be liable for consequential or other type damages resulting from the use of any of its products other than the liability stated above. This warranty is in lieu of all other warranties, express or implied, including, but not limited to the implied warranties of merchantability or fitness for use.

4356 Communications Drive • Norcross, GA 30093-2901 • Fax (770) 662-3696

Domestic Sales - (770) 662-3636
International Sales - (770) 662-3660

Domestic Repair Service - (770) 662-3666
Customer Service - (770) 662-3636

TABLE OF CONTENTS

1. USING THE ANALYZER

Introduction	1-1
Organization of the Operator's Manual	1-1
Conventions	1-3
EU Declaration of Conformity	1-3
Equipment Description	1-4
SediGraph III Plus	1-4
MasterTech 052	1-5
Instrument Components and Connectors	1-6
SediGraph III Plus - Front Panel	1-6
SediGraph III Plus - Side Panel	1-7
MasterTech 052 - Front Panel	1-8
MasterTech - Rear Panel	1-9
Turning the Analyzer On and Off	1-10
Turning the Analyzer On	1-10
Turning the Analyzer Off	1-10
Software	1-11
Shortcut Menus	1-11
Shortcut Keys	1-11
Files	1-13
Menu Structure	1-14
Specifications	1-16

2. OPERATIONAL PROCEDURES

Introduction	2-1
Editing the Sample Default File	2-1
Editing the Sample Default File	2-1
Defining Sample Information Files	2-3
Creating Sample Files in Advanced Format	2-4
Creating Sample Files in Basic or Restricted Format	2-6
Defining Parameter Files	2-8
Analysis Conditions	2-8
Defining a Liquid Properties File	2-12
Defining a Report Options File	2-14
Preparing for Analysis	2-17
Performing a Drain and Load Operation	2-17
Performing a Baseline Measurement	2-19
Performing an Analysis	2-21
Sample Analysis	2-21
Quick Start Analysis	2-26
Repeat Schedule	2-28
MasterTech Automatic	2-29

MasterTech Schedule	2-31
Performing a Rinse Operation	2-33
Rinse SediGraph	2-33
Rinse MasterTech	2-35
Rinse Both	2-36
Generating Reports	2-37
Status Display	2-38
Upper Display Items	2-38
Lower Display	2-38
Printing Files	2-39
Exporting Files	2-40
Listing Files	2-42
Converting Non-Windows Sample Files	2-43
Exit	2-45
Generating Overlays	2-46
Overlay Multiple Graphs from the Same Sample File	2-46
Overlay the Same Graph Type for Multiple Sample Files	2-49
Overlay the Same Type of Graph from the Same Sample File	2-52

3. FILE MENU

Introduction	3-1
Common Fields and Buttons - File Menu Options	3-1
Open	3-5
Sample Information Files - Advanced Format	3-6
Sample Information Files - Basic Format	3-8
Analysis Conditions Files	3-11
Material Properties	3-11
Analysis Options	3-18
Liquid Properties	3-21
Report Options Files	3-23
Collected / Entered Data	3-27

4. UNIT MENU

Introduction	4-1
Common Fields and Buttons - Unit Menu Options	4-2
Sample Analysis	4-3
Quick Start	4-6
Repeat Schedule	4-8
MasterTech Automatic	4-10
MasterTech Schedule	4-12
Baseline	4-15
Drain and Load	4-17
Rinse	4-19
SediGraph Rinse	4-19
MasterTech Rinse	4-21
Both	4-22
Initialize MasterTech	4-23

Enable Manual Control	4-24
Show Instrument Schematic	4-28
Show Status	4-29
Show Instrument Log	4-30
Unit Configuration	4-32
Calibration	4-34
Service Test	4-35

5. REPORTS MENU

Introduction	5-1
Common Fields and Buttons - Reports Menu Options	5-1
Start Report	5-3
Close Reports	5-3
Baseline Reports	5-4
SPC Report Options	5-5
Regression Report	5-8
Control Chart	5-10
PSD History	5-14
Report Features and Shortcuts	5-16
Report Header	5-16
Report Tool Bar	5-19
Report Shortcut Menus	5-22
Other On-Screen Features	5-28
Report Examples	5-29
Combined Report	5-29
Report by Size Class	5-30
Mass Frequency vs. Diameter Report	5-31
Rosin Rammler Graph	5-32
Summary Report	5-33
Cumulative Surface Area Coarser vs. Diameter	5-34
Surface Area Population vs. Diameter	5-35
Cumulative Particle Number Coarser vs. Diameter	5-36

6. OPTIONS MENU

Introduction	6-1
Option Presentation	6-1
Data Presentation	6-2
Sieves	6-3
Sample Defaults	6-3
Reynolds Number	6-3
Autorinse	6-4
System Configuration	6-4
Parameter Files Directory	6-5
Service Test Mode	6-5

7. TROUBLESHOOTING AND MAINTENANCE

Introduction	7-1
Troubleshooting	7-1
Preventive Maintenance	7-5
Schedule	7-5
Performing a Reference Material Analysis	7-6
Cleaning the Analyzer	7-6
Cleaning the Mixing Chamber and Bezel	7-6
Reconnecting the Mixing Chamber Tubing	7-7
Cleaning the Analysis Cell	7-8
Replacing Flexible Tubing	7-10
Cleaning the Air Filter	7-15
Checking the Operation of the Mixing Pump	7-16
Checking the Operation of the Cell Pump	7-17
Checking the Level of the Analyzer	7-18
Cleaning the Collimating Slits	7-18
Routine Maintenance	7-20
Replacing the X-Ray Indicator Lamps	7-20
Replacing the Cell Windows	7-21
Replacing the Analysis Cell Assembly	7-22
Determining the Cause of Bubbles	7-23
Resetting the Mixing Pump and Cell Pump	7-23
Replacing the Ultrasonic Probe Tip	7-24
Replacing the MasterTech Input Power Fuse	7-24

8. ORDERING INFORMATION

A. ERROR MESSAGES

B. SAMPLE DISPERSION

C. CHEMICAL AIDS FOR PARTICLE DISPERSION

D. STOKES' LAW

E. SEDIMENTATION THEORY

Calculations	E-1
Method of Analysis	E-4
System Operation	E-5
Particle Falling Rates	E-7
X-Ray Absorption	E-9

F. SEDIGRAPH RESULTS RELATIVE TO OTHER METHODS

G. LIQUID DENSITY AND VISCOSITY DATA

H. SOURCES OF DISPERSING AIDS

I. SEDISPERSE® PARTICLE DISPERSION LIQUIDS

Description	I-1
Storage Requirements	I-1
Technical Data	I-1
Material Properties	I-2
First Aid Treatment	I-2

J. DATA REDUCTION

Data Acquisition	J-1
Diameter	J-1
Liquid Properties Interpolation	J-2
Density	J-2
Viscosity	J-3
Mass Percent	J-3
Reduction of Collected Data	J-4
Mass Data	J-4
Mass Frequency Data	J-4
Cumulative Data	J-5
Peak Report Data	J-5
Number Frequency Data	J-7
Surface Area Frequency Data	J-7
Size Statistics	J-8
Standard Deviation of Quantity for N Tests	J-8
Mode	J-8
Median	J-8
Arithmetic Calculations	J-8
Geometric Calculations	J-10
Specification / Reference Quantities	J-11
Out of Spec	J-11
Difference from Reference	J-12
Maximum Out of Spec	J-12
Pass / Fail by Specification	J-12
SPC Report Variables	J-13
Regression Chart	J-13
Control Chart	J-14
Reynolds Number	J-14
Log Probability Data	J-15

K. SEDIGRAPH X-RAY SAFETY INFORMATION

General	K-1
X-ray Source	K-1
Warning / Indicator Lights	K-2

L. MASTERTECH INSTALLATION

Removing Packing Material From the Unit	L-1
Selecting the Voltage	L-1
Turning on the MasterTech	L-5
Installing the Beaker Tray	L-6
Connecting Cables	L-7
Installing the Ultrasonic Probe	L-8
Installing Sample Transfer Tubing	L-9
MasterTech with Serial Number 500 or Below	L-9
MasterTech with Serial Number 501 or Above	L-11
Verifying Operation	L-16

INDEX

1. USING THE ANALYZER

Introduction

This manual provides details on program menu options and operating instructions. This chapter contains information on the system hardware and software components.

To help operate the analyzer system more efficiently, refer to:

- Chapter 1, USING THE ANALYZER - prior to operating the analyzer and software
- Chapter 2, OPERATIONAL PROCEDURES - for step-by-step instructions for common operations

Organization of the Operator's Manual

This operator's manual is organized as follows:

Chapter	Description
Chapter 1	USING THE ANALYZER Provides a general description and features of the analyzer, organization of the manual, and software and instrument interface.
Chapter 2	OPERATIONAL PROCEDURES Provides step-by-step procedures for the operations available using the application.
Chapter 3	FILE MENU Provides a description of the File menu options and field and button definitions.
Chapter 4	UNIT MENU Provides a description of the Unit menu options and field and button definitions.
Chapter 5	REPORTS MENU Provides a description of the Reports menu options and field and button definitions.
Chapter 6	OPTIONS MENU Provides a description of the Options menu options and field and button definitions.

Chapter	Description (<i>continued</i>)
Chapter 7	<p>TROUBLESHOOTING AND MAINTENANCE</p> <p>Provides a description of the options contained on the Reports menu.</p>
Chapter 8	<p>ORDERING INFORMATION</p> <p>Provides ordering information for the application and analyzer system components.</p>
Appendix A	<p>ERROR MESSAGES</p> <p>Lists the error messages displayed by the analysis program; includes a cause and action for each.</p>
Appendix B	<p>SAMPLE DISPERSION</p> <p>Provides methods for dispersing samples.</p>
Appendix C	<p>CHEMICAL AIDS FOR PARTICLE DISPERSION</p> <p>Provides a list of dispersants and their active ingredients.</p>
Appendix D	<p>STOKES' LAW</p> <p>Provides calculations for Stokes' Law.</p>
Appendix E	<p>SEDIMENTATION THEORY</p> <p>Provides theoretical information on the sedimentation method.</p>
Appendix F	<p>SEDIGRAPH RESULTS RELATIVE TO OTHER METHODS</p> <p>Provides the relativity of the analysis results to other methods.</p>
Appendix G	<p>LIQUID DENSITY AND VISCOSITY DATA</p> <p>Provides density and viscosity data for common dispersants.</p>
Appendix H	<p>SOURCES OF DISPERSING AIDS</p> <p>Provides a list of suppliers for common dispersants.</p>
Appendix I	<p>SEDISPERSE® PARTICLE DISPERSION LIQUIDS</p> <p>Provides information on Sedisperse dispersing liquids.</p>
Appendix J	<p>DATA REDUCTION</p> <p>Contains the calculations used for producing reports.</p>

Chapter	Description <i>(continued)</i>
Appendix K	SEDIGRAPH X-RAY SAFETY INFORMATION Describes the safety features provided with the analyzer.
Appendix L	MASTERTECH INSTALLATION Describes how to install a MasterTech for use with the analyzer.
Index	INDEX Provides quick access to subject matter.

Conventions

This manual uses the following icons to identify notes of importance, warnings and cautions.



Notes contain important information pertinent to the subject matter.



Warnings contain information to help prevent actions that may cause personal injury.



Cautions contain information to help prevent actions that may damage the analyzer or components.

Equipment Description

SediGraph III Plus

The analyzer consists of up to two particle size analyzers and a multi-function computer. The particle size analyzer is mounted on adjustable feet and contains a level indicator so that accuracy of the analysis process is maintained. It is designed for completely automatic operation; however, a sliding transparent door on the front panel provides convenient observation of, and access to, the temperature-controlled analysis compartment.

The analyzer contains an internal fixed-position X-ray source, detector assembly, and a vertical cell movement assembly. It incorporates a complete system for circulation of sedimentation liquid and particle sample mixture between the cell, the external mixing chamber, an external rinse liquid container, and an external waste container. It also contains a detachable magnetic stirring assembly.



MasterTech 052

The MasterTech 052, an automatic sampling device that operates in conjunction with the SediGraph, is also available. The MasterTech allows up to 18 predispersed samples to be "queued up" and run consecutively and unattended. It allows samples to be redispersed either by stirring only or by stirring and disruption with an ultrasonic probe. The MasterTech transfers each sample to the SediGraph, then after analysis is complete, rinses the mixing chamber, the connecting tubing, and the stirrer.

The MasterTech 052 consists of three main components: the arm assembly, the body, and the beaker tray. The arm assembly controls the movement of the stirring rotor, the ultrasonic probe, and the transfer tube. The body houses the electronics, the transfer pump, the front panel controls, and supports the beaker tray, which holds up to 18 sample beakers.

During operation, the beaker tray is loaded with beakers containing 60 to 80 mL of predispersed sample. When the SediGraph is ready for a sample, the tray rotates until the correct sample is underneath the head of the arm assembly. The head then lowers until it rests on top of the beaker. Stirring action begins and continues for a user-specified length of time. The ultrasonic probe can be activated to aid in redispersion.

When redispersion is complete, the pump transfers most of the sample to the SediGraph, where it is loaded into the mixing chamber. Analysis now proceeds as if the mixing chamber was filled manually with predispersed sample. When analysis is complete, the contents of the mixing chamber are disposed to the waste container, and a small amount of rinsing fluid is back-flushed to the MasterTech to rinse the tubing. The arm rises so that the rinse liquid removes the sample residue from the stirrer blades and transfer tube. Once rinsing is complete, the arm rises to the Up position. The MasterTech is now ready to proceed to the next sample.

Instrument Components and Connectors

The system is fully automatic. The computer is used to enter operational information and view system status.

SediGraph III Plus - Front Panel



Component	Description
X-ray status	<ul style="list-style-type: none"> • X-Ray standby indicator - illuminates when the analyzer is ON and the X-ray keyswitch is turned to the standby position, when the door to the analysis compartment is open, or any interlock is disengaged. • X-Ray ON indicator - illuminates when X-rays are being generated. The X-ray keyswitch must be turned to the X-RAY ON position.
X-ray keyswitch	Sets the X-ray to either the On or Standby position.
Pump control Off/Auto switch	<p>Selects the operational mode of the mixing and cell pumps.</p> <p>The Off position turns off power to the pumps. The Auto position places the pumps in automatic mode.</p>

Component	Description <i>(continued)</i>
Mixing chamber	Contains the sample during an analysis and maintains sample dispersion throughout the analysis with a built-in stirrer.

SediGraph III Plus - Side Panel

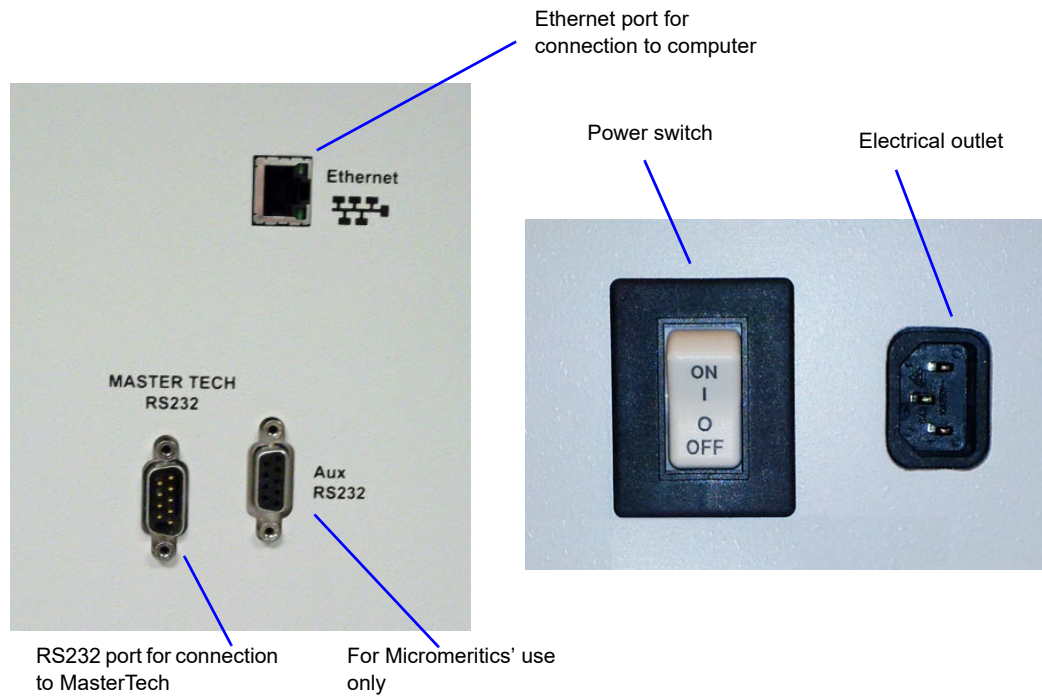

Component	Description
ON/OFF power switch	Turns electrical power to the analyzer on and off.
Electrical outlet	For connecting power to the analyzer.
Aux RS232 port	For Micromeritics use only.
MasterTech RS232 port	For connecting the MasterTech to the analyzer.
Ethernet port	For connecting the analyzer to the computer.

MasterTech 052 - Front Panel

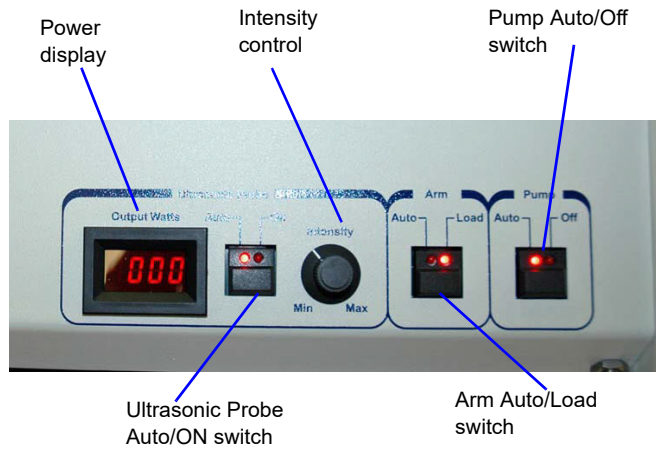

Component	Description
Power display	Displays the power being generated by the ultrasonic probe.
Ultrasonic probe AUTO/ON switch	<p>LEDs on the switch indicate the mode of operation.</p> <p>The AUTO position places the probe under automatic control.</p> <p>The ON position turns on the probe. Remove the probe from its holder and place it in the liquid before turning on the probe.</p>
<p>Never turn the probe on unless the tip is submerged in liquid.</p>	
	<p>After using the probe, press the switch again to place the probe in automatic mode. Then replace it in its holder.</p>
Intensity control	<p>Turn the control clockwise to increase the intensity of the probe. Turn it counterclockwise to decrease the intensity.</p>
Arm AUTO/LOAD switch	<p>The LEDs on the switch indicate the mode of operation.</p>
<p>Do not press the ARM AUTO/LOAD switch while an automatic operation is in progress.</p>	
	<ul style="list-style-type: none"> • AUTO - places the arm under automatic control. • LOAD - raises the arm to remove or load the tray. <p>This switch will not work unless the computer is installed and the analyzer software is operating.</p> <p>Ensure the LOAD switch has been released when finished removing or loading the beaker tray. The MasterTech will not operate if the arm is in the Load position.</p>



Component	Description <i>(continued)</i>
Pump AUTO/OFF switch	The LEDs on the switch indicate the mode of operation. The AUTO position places the pump under automatic control. The OFF position turns off power to the pump.

MasterTech - Rear Panel

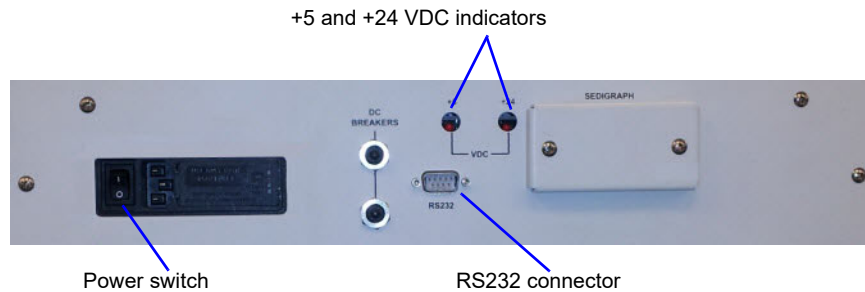

Component	Description
Power ON/OFF switch	Turns the MasterTech on and off. The down (O) position turns off the MasterTech. The up () position turns on the MasterTech.
+5 and +24 VDC indicators	Illuminates when appropriate power is present in the MasterTech.
RS232 connector	Used to connect the MasterTech to the analyzer.

Turning the Analyzer On and Off

Turning the Analyzer On

1. Place the computer, monitor and printer ON/OFF switches in the ON position.
2. Place the Pump Control switch (located on the front panel) in the AUTO position.
3. Place the analyzer ON/OFF switch (located on the side panel) in the ON position.
4. Insert the X-ray key into the X-ray keyswitch then turn the switch to the X-RAY ON position.
5. Wait 30 minutes for the analyzer to warm up before performing an analysis.



It is recommended that the analyzer remain on unless it is going to be idle for a period of more than 24 hours. Leaving the analyzer on helps prolong the life of its major components.

Turning the Analyzer Off



Always exit the analysis program before turning off the computer. Failure to do so could result in loss of data.

It is recommended that the analyzer be turned on at all times. If it does become necessary to turn it off, perform these steps:

1. Go to **File > Close** or **File > Exit**.

If an analysis is in progress, the following message is displayed:

Instrument is busy. Continue program exit?

Select Yes and the analysis program closes. The analysis continues and data continue to be collected. Queued reports under the printer will print. If a power failure occurs and an uninterruptible power supply (UPS) is not attached to the analyzer, the data collected *after exiting* the analysis program are lost

Select **No** and the program remains open and the analysis continues to run.

2. Shut down the computer using standard Windows procedure.
3. Place the monitor and printer ON/OFF switches in the OFF position.
4. Place the analyzer ON/OFF switch in the OFF position.

Software

The analysis program operates in the Windows environment and requires familiarity with standard Windows operations, for example, using the mouse, menus and windows. While this manual provides brief instructions for such standard operations, if necessary, refer to Windows documentation or its online help system to clarify any Windows functions.

Shortcut Menus

Shortcut menus are available for:

- the instrument schematic when Manual Control is enabled. Refer to [Enable Manual Control](#), page 4-24.
- onscreen graphs and tabular reports. Refer to [Report Shortcut Menus](#), page 5-22.

Shortcut Keys

Shortcut keys can be used to activate some menu commands. Shortcut keys or key combinations (when applicable) are listed to the right of the menu item.

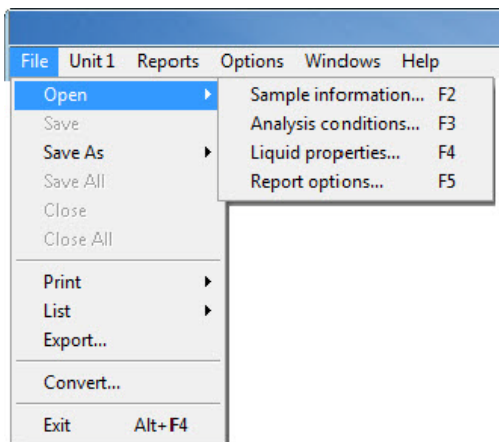

Another shortcut method of accessing a menu or function is to use the **Alt** key plus the underlined letter in the menu command. For example, to access the **F**ile menu, press **Alt+F**.



If the underscored letters do not display menus and windows, press the Alt key on the keyboard.

Shortcut Key(s)	Function
F1	Accesses the online operator's manual.

Shortcut Key(s)	Function (<i>continued</i>)
F2	Opens a file selection window that displays sample information files.
F3	Opens a file selection window that displays analysis conditions files.
F4	Opens a file selection window that displays liquid properties files.
F5	Opens a file selection window that report options files.
F6	Tiles open windows.
F7	Cascades open windows.
F8	Opens a file selection window that displays reports to run.
F9	Closes all open reports.
Alt + F4	Exits the program. If files are open with unsaved changes, a prompt to save changes displays.

Files

File Status and Description

In the File Selector window, the Mic Description column and the Mic Status column display file description and file status, respectively.

File Status	Description
Analyzing	Sample information files that are currently being used for analysis.
Complete	Sample information files used in an analysis that has been completed.
Entered	Sample information files containing manually entered data.
No Analysis	Sample information files which have not been used to perform an analysis.

File Name Conventions

For sample information files, a default file name (the next available sequence number) and a default file extension display. For Analysis conditions, Report options, and Liquid properties files, only a default file extension display.

The following table lists the default file extensions assigned to program files:

File Type	Default File Name Extension
Analysis conditions	.ANC
Export to disk (ASCII)	.EXP
Liquid Properties	.LIQ
List to disk	.LST
Report options	.RPO
Report to disk	.RPT
Report (saved from the report window)	.REP
Sample information	.SMP
For conversion from non-Windows SediGraph 5100	.DAT

Menu Structure

All program functions are located on menus accessed from the menu bar. Each menu contains commands and, in some cases, a submenu. A submenu is indicated when the command is followed by an arrow.

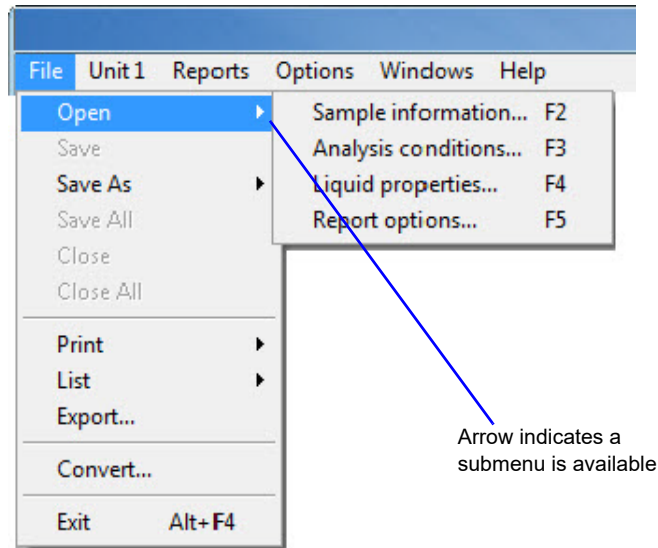

Main Menu Bar

All program functions are accessed from the main menu bar. The following table contains brief menu descriptions and links to additional information:

Menu Item	Description
File	Use to access files. Refer to FILE MENU , page 3-1 .
Unit [n]	Use to perform analyses, calibrations and other instrument operations. Refer to UNIT MENU , page 4-1 .
Reports	Use to run reports and view the results. Refer to REPORTS MENU , page 5-1 .
Options	Use to edit sample defaults, specify the printer for reports, and select data presentation formats. Refer to OPTIONS MENU , page 6-1 .
Windows	Use to arrange open windows and display a list of open windows. Refer to Windows Menu , page 1-15 .
Help	Displays help information. Refer to Help Menu , page 1-15 .

Windows Menu

The Windows menu lists open files and provides the ability to rearrange the way open windows display. A check mark appears to the left of the active window.

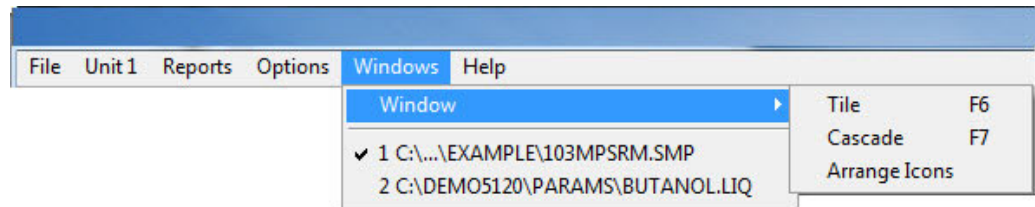

Window Menu Option	Description
Cascade	Stacks open windows in a fanned format so that each window title bar is visible. F7 can also be used as a keyboard shortcut.
Tile	Resizes open windows and arranges windows horizontally so that multiple windows can be viewed at once. F6 can also be used as a keyboard shortcut.
Arrange Icons	Arranges the symbols for all minimized windows.

Help Menu

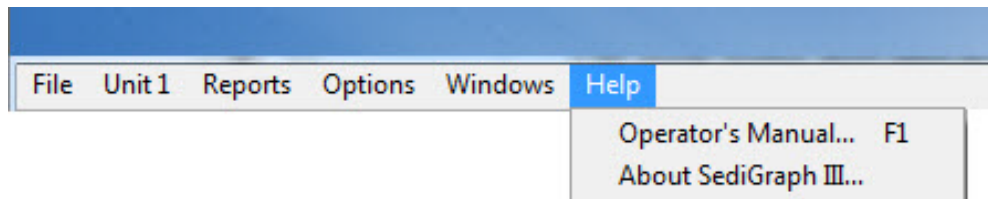

Help Menu Option	Description
Operator's Manual	Provides access to the online operator's manual.
About SediGraph III Plus	Provides the analysis program version number.

Setup Program

The Setup program is located on the installation CD. It is used to:

- Upgrade or re-install the software
- Add an analyzer
- Move an analyzer from one computer to another computer
- Remove an analyzer from the computer
- Change the analyzer setup
- Reinstall calibration files
- Uninstall the analysis program

Specifications

The SediGraph III Plus has been designed and tested to meet the following specifications:

Characteristic	Specification
Analyzer	
Particle Diameter Range	300 to 0.1 μm Equivalent Spherical Diameter
Resolution	The sedimenting sample is scanned by a narrow x-ray beam - less than 0.2% of the total distance scanned - permitting high resolution.
Wetted Materials	Stainless steel, Teflon [®] impregnated anodized aluminum, nickel plated aluminum, nylon, polypropylene, polystyrene, Tygon [®] tubing, tungsten carbide, Ertalyte [®] , Viton [®] , Kalrez [®] , glass, and epoxy.
Sample Size	50 mL of dispersed sample; precise concentration is not required
Suspending Liquids	Any liquid compatible with sample cell materials and not highly absorptive of X-rays (typical liquids are water, glycols, mineral oils, Sedisperse [®] , and alcohols)
Voltage	85 to 264 VAC
Frequency	47 to 63 Hz
Power	450 VA
Temperature	Ambient +10 to 40 °C, operating; -10 to 55 °C, storing or shipping

Characteristic	Specification (continued)
Humidity	Up to 90% relative (non-condensing); 20 to 80% for computer and components
Physical	Height: 52 cm (20.5 in.) Width: 50.5 cm (20 in.) Depth: 58 cm (23 in.) Weight: 43 kg (95 lb)
Computer	
Minimum requirements	Windows 2000 or higher operating system with an Ethernet port
MasterTech	
Sample Capacity	18 per tray; continuing indefinitely if tray is replenished
Sample Size	18 per tray; continuing indefinitely if tray is replenished
Suspending Liquid	Any liquid compatible with wetted materials (typical liquids are water, glycols, mineral oils, alcohols, SediSpense [®] , (and mineral spirits)
Wetted Materials	Stainless steel, Viton [®] , Tygon [®] , silicone rubber, polypropylene
Voltage	100, 120, 220 or 240 VAC \pm 10%
Fuse	2A (100/120 VAC); 1A Type T, Slow-Blow (220/240 VAC)
Power	250 VA
Frequency	50/60 Hz.
Temperature	10 to 40°C, operating: -10 to 55°C, storing or shipping
Humidity	20 to 80% relative (non-condensing)
Physical	Height: 71 cm (28 in.) Width: 46 cm (18 in.) Depth: 53 cm (21 in.) Weight: 18 kg (40 lbs)

2. OPERATIONAL PROCEDURES

Introduction

This chapter contains information on:

- specifying sample defaults
- creating sample files in advanced, basic, and restricted formats
- defining parameter files
- preparing for analysis
- performing a baseline measurement
- performing an analysis
- performing a rinse operation
- generating overlays
- exporting, listing and converting file contents to the screen, printer, or file

Editing the Sample Default File

Sample files include the information required by the analyzer to perform analyses and collect data. A sample default file is a template for sample files that contains the parameters to be used for an analysis. The analysis software contains a sample default file. When creating a new sample information file, all of the parameters are filled with the values in the sample default file and can be edited if necessary.

Editing the Sample Default File

1. Go to **Options > Option presentation > Advanced**. Ensure a checkmark appears to the left of **Advanced**.
2. Go to **Options > Sample defaults**.

5120 Sample Defaults

<< Prev | Sample Information | Material Properties | Analysis Options | Report Options | Next >>

Sequence Number: 000-001

Sample: \$

Operator: [] Omit

Submitter: [] Omit

User Parameters

Parameter 1	0.000	[] Omit
Parameter 2	0.000	[] Omit
Parameter 3	0.000	[] Omit

Comments []

Replace All...

Save | Close | Basic

3. In the **Sequence Number** text box, specify an optional default alphanumeric file sequence string. This field must contain a minimum of 3 numbers. As files are created, this number is incrementally sequenced as a part of the file name and will also display in the **Sample** text box when a sample file is created.
4. In the **Sample** text box, enter a format for the default sample identification. Include the \$ character to automatically include the contents of the **Sequence Number** field and **Sample file name** field as part of the sample identification.
5. Enter default **Operator** and **Submitter** identification information in the respective text boxes. This information will display in the **Sample Information** tab of new sample information files.



The labels for the Sample, Operator, and Submitter fields can be modified by overwriting the default labels. These fields can also be omitted from a sample file by selecting the Omit checkbox.

6. The optional user-defined fields in the **User Parameters** group box may be used to enter and track information from another instrument or source, along with other statistical process control (SPC) data.



The labels for the User Parameter fields can be modified by overwriting the default labels. These fields can also be omitted from a sample file by selecting the Omit checkbox.

7. Use the **Comments** text box to enter notes about the default sample.



The << Prev and Next >> buttons can be used to navigate between tabs.

8. Select the **Material Properties** tab. Select the options to be used as defaults, then click **Save**. Refer to [Analysis Conditions](#), page 2-8.
9. Select the **Analysis Options** tab. Select the analysis options to be used as defaults, then click **Save**. Refer to [Analysis Conditions](#), page 2-8.
10. Select the **Report Options** tab. Select the report options to be used as defaults, then click **Save**. Refer to [Defining a Report Options File](#), page 2-14.
11. Click **Save**, then **Close**.

Defining Sample Information Files

A sample information file must be created for each analysis. This file can be created prior to or at the time of analysis. The sample information file identifies the sample, guides the analysis, and specifies report options.

A sample information file may be created in Advanced, Basic, or Restricted format.

Format	Description
Advanced	Displays all parts of sample information and parameter files. Navigate to parameter windows by selecting the tabs across the top of the window.
Basic	Displays the entire sample information file in a single window with no tabs across the top. This option is used once the parameter files have been created. The previously entered or default parameter files are then accessible using dropdown lists.
Restricted	Displays the sample information file in a single window similar to the Basic format with certain functions disabled. A password is set when the restricted format is selected. That same password must be entered to change the format. This format is typically used in laboratories where analysis conditions must remain constant, for example, in the pharmaceutical industry. The Advanced format option is not available from the Restricted presentation format.

Creating Sample Files in Advanced Format

The values specified in the parameter portions of the sample default file (Analysis Conditions and Report Options) are saved as the defaults for new sample files. To navigate from one set of parameters to another, select the parameter tab at the top of the window or use the << **Prev** and **Next**>> buttons.

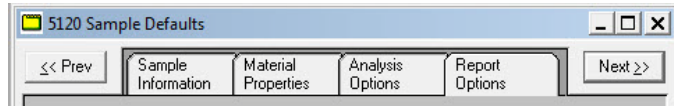

1. Go to **Options > Option presentation > Advanced**. Ensure a checkmark appears to the left of **Advanced**.

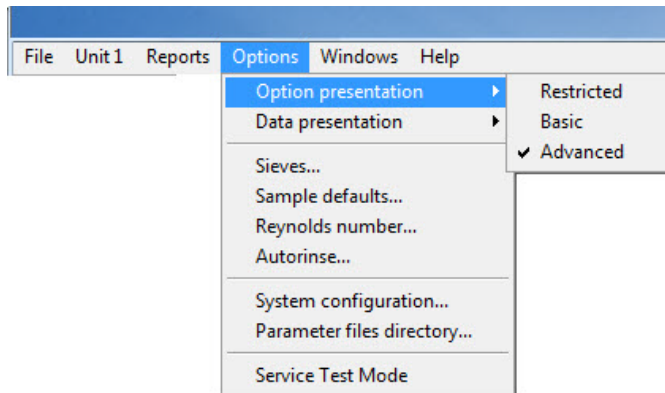

2. Go to **File > Open > Sample Information**.

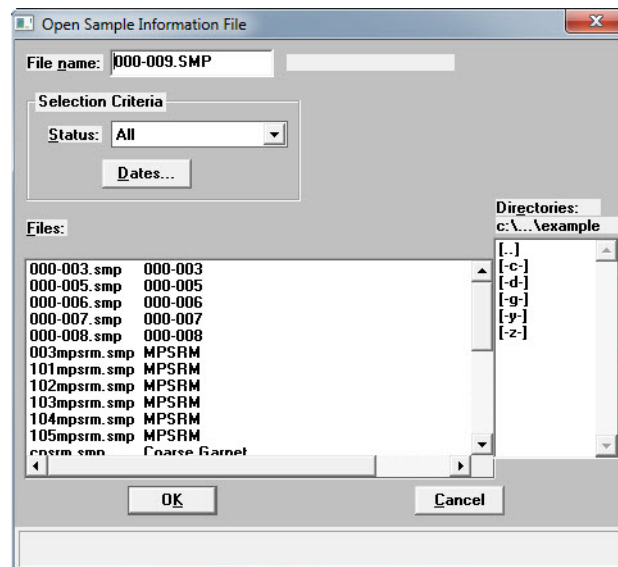

3. Accept the next sequenced file number or enter a new name in the **File name** field. Click **OK** and respond **YES** to the prompt to create a new file.

4. Enter a sample description in the **Sample** text box.

5. Enter **Operator** and **Submitter** identification information in the respective text boxes. Some text box fields may have been renamed or may not display if modified in *Options > Sample Defaults*.
6. If SPC (Statistical Process Control) information is to be reported, enter appropriate information in the **User Parameters** group box. These are user-definable parameters that can be entered and tracked along with other statistical process control data. Some text box fields may have been renamed or may not display if modified in *Options > Sample Defaults*.
7. Enter any pertinent information about the sample information file in the **Comments** text box. Comments are displayed in the report header.
8. Click the **Add Log Entry** button to enter notes for the instrument log report. Create entries that cannot be recorded automatically through the application software. For example, record that the port filter was changed.

9. After completing the **Sample Information** window, click the parameter tabs to edit other sample information file parameters. See [Defining Parameter Files](#), page 2-8.



The << Prev and Next >> buttons can be used to navigate between tabs.

Creating Sample Files in Basic or Restricted Format

The Basic and Restricted formats use predefined parameter files to create a sample information file. If using Restricted format, a password is required to enter and exit Restricted format mode.

- When using the Basic format, switch to the Advanced format to edit parameter file values.
 - When using the Restricted format, parameter files cannot be edited.
1. Go to **Options > Option presentation > Basic (or Restricted)**. Ensure a checkmark appears to the left of **Basic**.

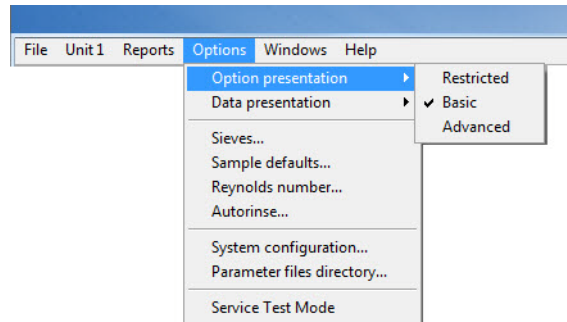

2. Go to **File > Open > Sample Information**.

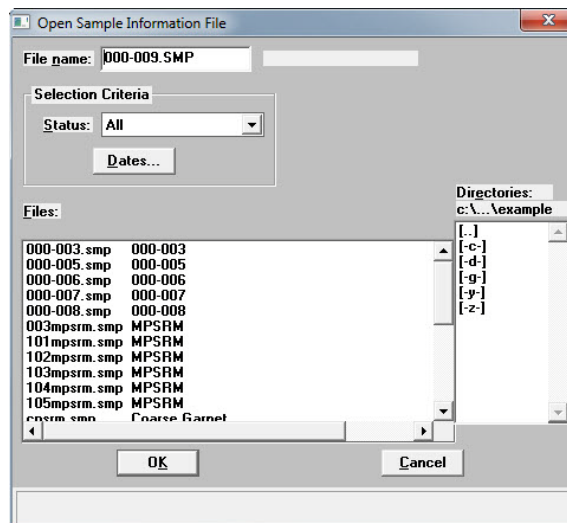

3. Accept the next sequenced file number or enter a new name in the **File name** field. Click **OK** and respond **YES** to the prompt to create a new file.

- Select an Analysis Conditions set from the dropdown list.

- Select the **Rinse after analysis** option.



It is highly recommended that the Rinse after analysis option remain selected. Deselecting this option may speed up analyses, but inaccurate data may be produced.

- Select a **Report Options** file from the dropdown list.
- In the **Report Options** list box, select any reports to be generated. A checkmark to the left of the report option indicates the report has been selected.
- In the **Full scale mass percent** field, enter the percentage of the sample to be analyzed. Unless planning to analyze a portion of the sample by some other method, this should be left at 100%.



To merge data collected by another method with the data collected with this analysis, skip this step.

- To merge alternatively collected data with the data to be collected with the active file, select **Merge with external data**. Refer to [Sample Information Files - Basic Format](#), page 3-8.
 - Click **External Data** and select whether the external data is particle size or sieve size.
 - In the table, enter the data (particle size or sieve) collected from the alternative method.
 - Choose the type of distribution provided by the external analysis method.
 - Click **OK**.
- Click **Save**, then **Close**.

Defining Parameter Files

The following file types can exist as part of the sample information file as well as individual parameter files:

- Analysis Conditions .ANC file extension
- Liquid Properties .LIQ file extension
- Report Options .RPT file extension

Default parameter files can be used for multiple analyses without having to re-enter the values each time an analysis is performed.

Predefined parameter files are included with the program and can be edited as needed or new parameter files can be created. The **Replace** button can be used to overwrite values from an existing file. Changes can be made as needed to the new file while the original file remains unchanged.

Analysis Conditions

Analysis conditions specify the data used to guide an analysis and consists of three sets of data:

- **Material Properties** - defines sample material, liquid properties, and type of analysis. Refer to [Material Properties](#), page **2-9**.
- **Liquid Properties** - defines certain physical characteristics of sedimentation liquids. Refer to [Defining a Liquid Properties File](#), page **2-12**.
- **Analysis Options** - defines MasterTech operation and analysis conditions. Refer to [Analysis Options](#), page **2-11**.

Material Properties

File > Open > Analysis conditions [file] (or use the F3 keyboard shortcut)

Material Properties define the sample material, the liquid properties, and the type of analysis to be performed.

1. Go to **File > Open > Analysis conditions**.
2. Enter a file name in the **File name** text box and click **OK** when prompted to create a new file.
3. Go to the **Material Properties** tab.

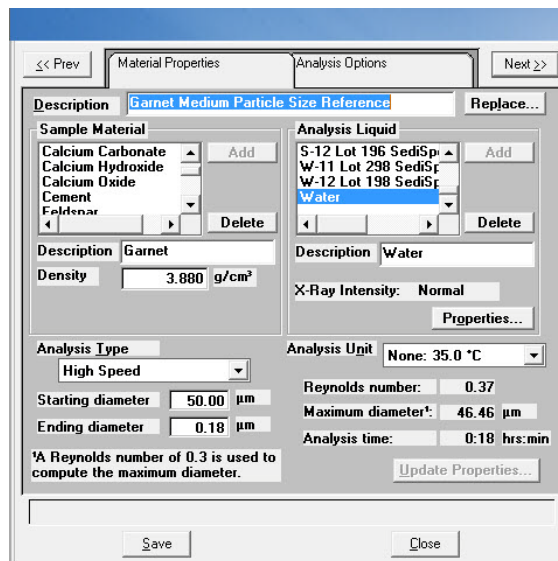

4. Enter a description in the **Description** field.
5. Select a sample material in the **Sample Material** list box. To add a sample material not displayed:
 - a.) Enter the sample material to be added in the **Description** field below the **Sample Material** list box.
 - b.) Enter the material's density in the **Density** field.
 - c.) Click **Add**. The sample material is added to the **Sample Material** list.
6. Select a dispersing liquid in the **Analysis Liquid** list box. To add a dispersing liquid not displayed:
 - a.) Enter the dispersing liquid to be added in the **Description** field.

- b.) Click the **Properties** button. Select the **Fixed values** option and enter the viscosity and density for the liquid. Click **OK**. Refer to [Defining a Liquid Properties File](#), page 2-12.

Liquid Properties

Description: Defaults for Water

Current Cell Conditions

Target Unit: None

Temperature: 35.0 °C

Viscosity: 0.7225 mPa·s

Density: 0.9941 g/cm³

Fixed values (ignore temperature)

Density: 1.0000 g/cm³

Viscosity: 1.0000 mPa·s

Interpolate using cell temperature

	Temp. °C	Density g/cm³	Viscosity mPa·s
1	26.0	0.9968	0.8737
2	32.0	0.9951	0.7679
3	38.0	0.9930	0.6814

X-Ray intensity: Normal Low

OK Cancel

Enter a value between 0.0 and 100.0.

- c.) Click **Add**. The dispersing liquid is added to the list.
7. Select an analysis type in the **Analysis Type** dropdown list.
 8. Enter the starting and ending diameters in the **Starting Diameter** and **Ending Diameter** text boxes. Generally, the starting diameter should be larger than the largest particle expected to be in the sample. The ending diameter must be less than the smallest size particle of interest.
 9. The **Maximum diameter** field should be greater than the starting diameter specified in step 8. The **Reynolds number** should be less than 0.3.

If...	Then...
The maximum diameter and Reynolds number values are not attained	A dispersing liquid with a higher viscosity must be used.
The maximum diameter is much greater than the starting diameter and the Reynolds number is much less than 0.3	A lower viscosity liquid (if available) may be used.

Analysis Options

File > Open > Analysis conditions [file] (or use the F3 keyboard shortcut)

Analysis Options define MasterTech operation and analysis conditions.

1. Go to **File > Open > Analysis conditions**. If continuing from the instructions in the **Materials Properties** section, skip to Step 3.
2. Enter a file name in the **File name** text box or select an existing file. Click **OK** if prompted to create a new file.
3. Click the **Analysis Options** tab.

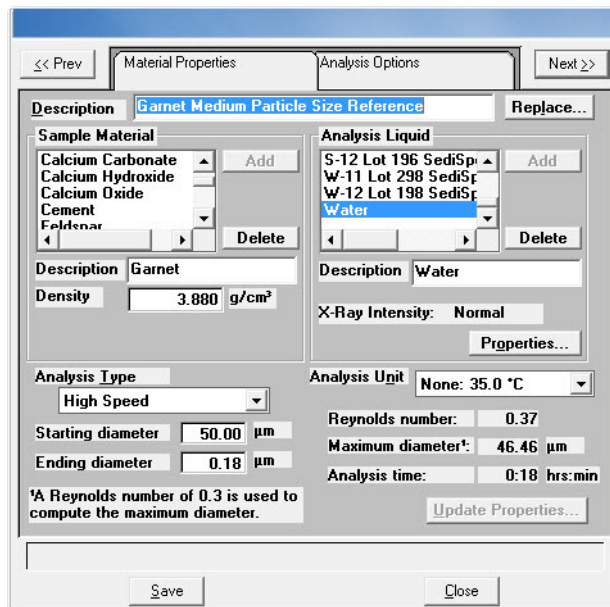

4. If a MasterTech attached to the analyzer, in the **MasterTech Treatment** group box, enter the stirrer time, stirrer speed and probe time.
5. Select **Stop at selected mass percent** if the analysis should be stopped at a specified mass percent finer. Enter the point where the analysis should stop.
6. In the **Number of tests** box, enter up to 8 tests (analyses) to be performed.
7. Select **Leave pump on during analysis** to have the mixing pump operate during analysis. Coarse materials tend to settle in the tubing during analysis. Allowing the mixing pump to operate during analysis will make rinsing and resuspension more thorough.
8. Select **Wait for temperature stabilization** to have the temperature in the analysis compartment and mixing chamber stabilize before the analysis begins. Since liquid properties are defined from the analysis compartment temperature, analyses are more accurate if the mixing chamber and analysis compartment have the same temperature range.
9. Enter the mixing chamber speed in the **Mixing chamber stirrer speed** text box.

10. In the **Full Scale Scan** group box:
 - a.) Enter the cell pump operating speed during the scanning process in the **Pump Speed** text box.
 - b.) Select a bubble detection of **Coarse**, **Medium**, or **Fine** in the **Bubble detection** dropdown list.
11. In the **Rinse** group box:
 - a.) Select if the analysis cell should be rinsed after each analysis:
 - **Autorinse** - the analysis cell is rinsed automatically.
 - **Rinses** - specify the number of rinses
 - b.) Enter the cell pump speed during the rinsing process.
12. Click **Save**, then **Close**.

Defining a Liquid Properties File

File > Open > Liquid properties [file] (or use the F4 keyboard shortcut)

Liquid properties files provide certain physical characteristics of sedimentation liquids used for analysis. The physical characteristics are the density and viscosity of the liquid at different temperatures.

Several liquid properties files, located in the PARAMS subdirectory, are included with the analysis program.



Refer to Appendix G **LIQUID DENSITY AND VISCOSITY DATA** for a list of some common dispersants and their density and viscosity values.

1. Go to *File > Open > Liquid properties*.

2. Enter a file name in the **File name** text box and click **OK** when prompted to create a new file.

Liquid Properties

Description:

Fixed values (ignore temperature)

Density: g/cm³

Viscosity: mPa·s

Interpolate using cell temperature

	Temp. °C	Density g/cm ³	Viscosity mPa·s
1	26.0	0.9968	0.8737
2	32.0	0.9951	0.7679
3	38.0	0.9930	0.6814

X-Ray intensity: Normal Low

3. Enter a description in the **Description** field.
4. Select one of the following:
 - **Fixed values (ignore temperature)** - enter values in the **Viscosity** and **Density** fields. These values will be maintained regardless of the cell temperature.
 - **Interpolate using cell temperature** - enter three sets of values for the temperature, viscosity and density. These values are used to interpolate the density and viscosity at the current cell temperature as long as the instrument operating temperature remains within these ranges.

The table requires that entered values be properly ordered. For example, Temperature should be in ascending order. Enter values from left-to-right and from top-to-bottom.
5. Select the X-ray intensity:
 - **Normal** - increases intensity when using high X-ray absorption liquids, such as water.
 - **Low** - decreases intensity when using low X-ray absorption liquids, such as hydrocarbons.
6. Click **Save**, then **Close**.

Defining a Report Options File

File > Open > Report options [file] (or use the F5 keyboard shortcut)

Report options files specify the types of reports which can be generated from an analysis or from manually-entered data. They also contain details of the reports such as axis scale, axis range, and column headings. These report options files may be used to generate reports automatically at any time during or after the analysis.

Report options files may be created and stored, then used with any sample information file. A report options file may contain tabular reports only, graphs only, or both. It may also contain user defined report tables.

Report options files also may be defined to include overlay options. The analyzer can overlay up to seven graphs of different samples onto an eighth graph of the same type. The system can also overlay one graph type onto a different graph type from the same sample analysis. For example, a cumulative mass graph may be overlaid with a mass frequency graph.

Several report options files are included in the analysis program and are located in the PARAMS sub-directory.

1. Go to **File > Open > Report Options**.
2. Enter a file name in the *File name* text box and click **OK** when prompted to create a new file.

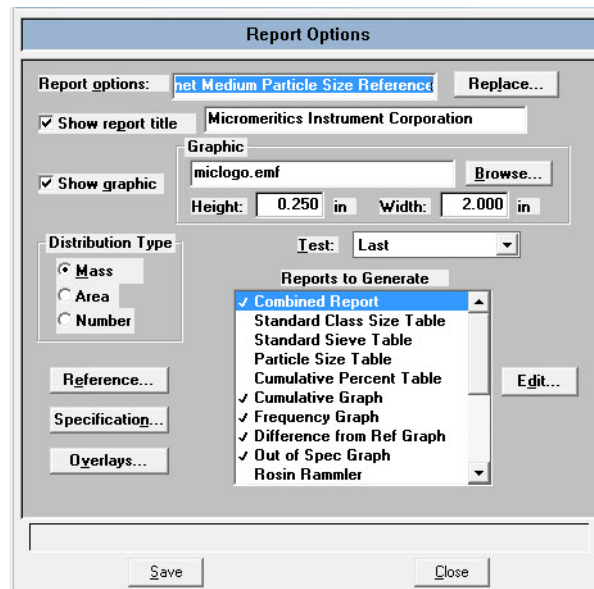

3. Enter a description in the **Report options** field.
4. To display a title on the report header, select the **Show report title** checkbox and enter the report title in the text box. Refer to [Report Header](#), page 5-16.

5. To display a graphic on the report header, select the **Show report title** checkbox and enter the report title in the text box. Click the **Browse** button to locate a .BMP or .EMF file. Specify the graphic size in the **Height** and **Width** text fields. Refer to [Report Header](#), page **5-16**.
6. Select the data distribution type to be used for reports.
7. To compare analysis results for the current sample to those obtained for a reference sample, click **Reference** and select a file. Results are reflected in the **Difference from Reference Graph** report. Click **OK** after selecting a file.

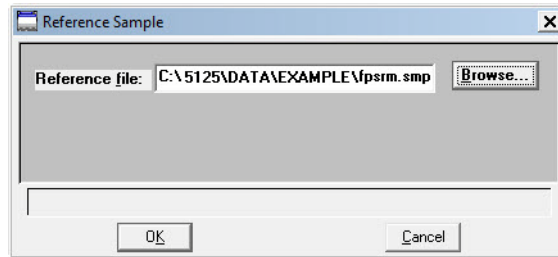

8. To determine if the results for the current sample are within coarse and fine specifications, click **Specification** and select a sample file for each boundary. Results are reflected in the **Out of Specification Graph** report. Click **OK** after selecting a file.

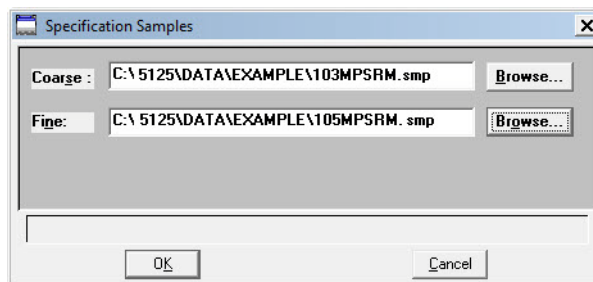

- To overlay graphs, click **Overlays** and choose the sample file(s) to overlay with the current sample. Click **OK** after selecting files.

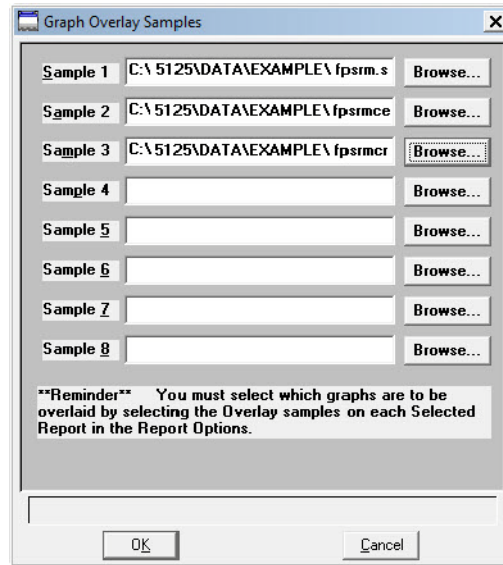

- From the **Test** dropdown list, select the analysis report to be generated (**Average, First, Last**).
- In the **Reports to Generate** list box, select which reports are to be generated. Selected reports will have a checkmark to the left of the report name.
 - Double-click the report to place a checkbox to the left of the report.
 - To specify report options, highlight the report in the **Reports to Generate** list box and click **Edit**. Make changes as necessary. Click **OK**.
- Click **Save**, then **Close**.

For information on Overlays, refer to [Generating Overlays](#), page 2-46.

Preparing for Analysis

Before collecting baseline data or perform an analysis, the cell and mixing chamber must be drained and the sample (or baseline liquid) loaded.

A baseline measurement must be performed before running analyses. It is not necessary to measure a baseline for each analysis; however it is recommended that a baseline measurement be performed once per shift and when changing dispersing agents.

Performing a Drain and Load Operation

Unit [n] > Drain and load

Before collecting baseline data or performing an analysis, the cell and mixing chamber must be drained and the sample (or baseline liquid) loaded.

- Prior to a baseline collection or an analysis, go to *Unit > Drain and load*.
- At the beginning of a baseline collection, select the **Prepare SediGraph to load baseline liquid** check box on the **Baseline Measurement** window. Refer to [Performing a Baseline Measurement](#), page 2-19.
- At the beginning of an analysis, select the **Prepare SediGraph to load sample** check box on the **Drain and Load** window. Refer to [Performing an Analysis](#), page 2-21.

1. Go to *Unit [n] > Drain and load*.

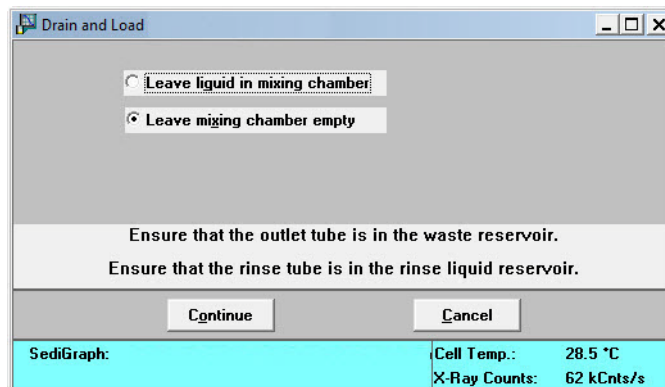

Ensure that the outlet tube is in the waste reservoir and that the rinse tube is in the rinse liquid reservoir.

2. Select to either have the liquid remain in the mixing chamber or leave the mixing chamber empty. Click **Continue**.

3. A progress message appears prior to the following window. Ensure the mixing chamber bezel is inserted in the mixing chamber, then load the sample (or baseline liquid) into the mixing chamber. The mixing speed can be changed using the **Increase** or **Decrease** button.

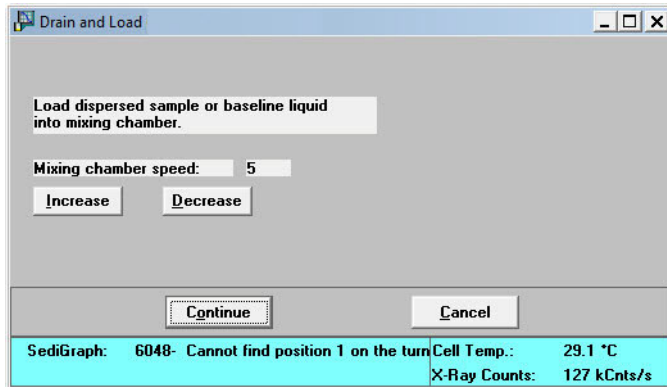

4. Click **Continue**.

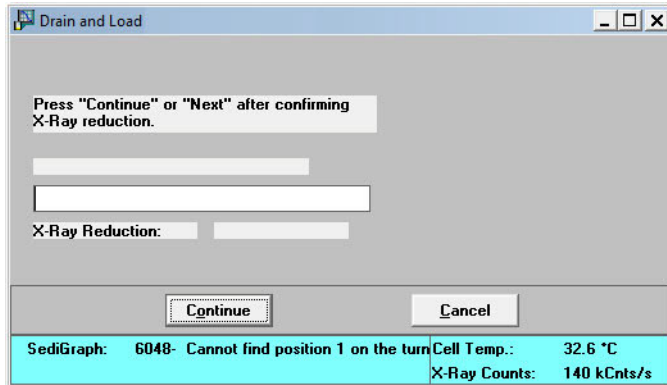

Confirm the X-ray intensity reduction over the baseline before it completes:

- **Good** - indicates reduction is between 30 and 75% meaning that the concentration level is appropriate.
 - **Low** - indicates the reduction is less than 30% meaning that the concentration is too low and sample should be added.
 - **High** - indicates the reduction is more than 75% meaning that the concentration is too high and more dispersant or less sample should be used.
5. When the X-ray reduction level is set, click **Continue** and the cell will move to the normal park position and the load operation will be complete.

Performing a Baseline Measurement

Unit [n] > Baseline

A baseline measurement is required for data collection. Although it is not necessary to measure a baseline for each analysis, Micromeritics recommends that a baseline measurement be performed once per shift and when changing dispersing agents. Up to seven baselines can be measured; however, only the last one may be saved.



Ensure that the outlet tube is in the waste contains that no sample is present in the system.

1. Go to *Unit [n] > Baseline*.

The screenshot shows the 'Baseline Measurement' dialog box. It has several sections: 'Prepare to load baseline liquid' with three radio button options: 'Prepare to load baseline liquid' (checked), 'Leave liquid in mixing chamber', and 'Leave mixing chamber empty'. 'Report After Analysis' section includes a checkbox (checked), 'Number of Reports' (1), 'Destination' (Printer), and 'File name' (C:\DEM05125*.RPT). 'X-Ray intensity' has radio buttons for 'Normal' (checked) and 'Low'. Below these are instructions: 'Ensure that the outlet tube is in the waste container.' and 'Ensure that no sample is present in the system.' At the bottom are buttons for '<< Prev', 'Next >>', 'Cancel', and 'Close'. A status bar at the bottom shows 'SediGraph: Cell Temp.: 26.4 °C' and 'X-Ray Counts: 10 kCnts/s'.

2. If the baseline liquid has not been loaded into the mixing chamber:
 - a.) Select **Prepare to load baseline liquid**.
 - b.) Select to have the liquid remain in the mixing chamber or to leave the mixing chamber empty.



If planning to use a liquid *different* from the one used for rinsing, select Leave mixing chamber empty.

3. To have a baseline report generated:
 - a.) Select **Report After Analysis**.
 - b.) Select the report destination.

c.) If **Printer** was selected, enter the number of copies to print.



File cannot be specified as the destination for baseline reports. Only tabular reports can be output to a file.

4. Select the X-ray intensity setting.

- **Normal** - increases intensity when using high X-ray absorption liquids, such as water.
- **Low** - decreases intensity when using low X-ray absorption liquids, such as hydrocarbons.

5. Click **Next >>** to display a window containing the previous baseline. This window also displays the new (current) baseline as it is measured.



If Prepare to load baseline liquid was selected, a drain and load operation is performed first.



If this baseline is not satisfactory, perform another baseline by clicking Next >>. If another baseline is measured, the current one will become inaccessible.

6. The window displays an upper status. Click on the **Baseline to use** dropdown to select **Latest** (for the current baseline) or **Previous** (to use the previously saved baseline).

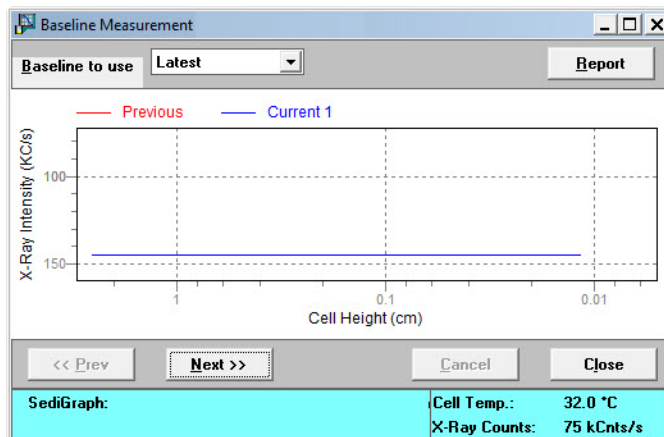

Performing an Analysis

An analysis can be performed in one of five ways:

- **Sample Analysis** - performs a single sample analysis.
- **Quick Start Analysis** - performs analyses on multiple samples using the same analysis conditions. Sample files are generated automatically.
- **Repeat Analysis** - performs multiple analyses on the same sample.
- **MasterTech Automatic** - analyzes a series of samples of the same type with the same analysis conditions. Functional only if a MasterTech is installed.
- **MasterTech Schedule** - analyzes a series of samples which are different in size and shape and, consequently, require different analysis conditions. Functional only if a MasterTech is installed.

Sample Analysis

Unit [n] > Sample analysis

To perform an analysis on only one sample:

1. Go to *Unit [n] > Sample Analysis*.
2. Click **Browse** to select a sample to analyze.

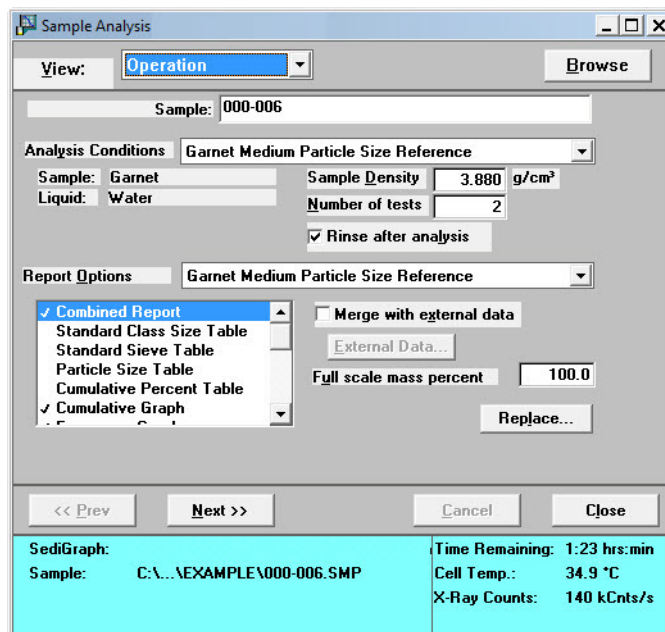

3. Verify the analysis conditions and report options.

4. In the **Full scale mass percent** field, enter the percentage of the sample to be analyzed. It is recommended that the percentage be left at 100% unless only a portion of the sample will be analyzed using an alternate method.



To merge data collected by another method with the data collected with this analysis, skip Step 5.

5. To merge alternatively collected data with the data to be collected with this file, select **Merge with external data**.

a.) Click **External Data** button.

	Particle Diameter (µm)	Cumulative Finer Percent
1	0.1000	100.00

- b.) Select if the external data is particle size or sieve size.
 - c.) Enter the particle size or sieve size of the data collected from the alternative method into the table.
 - d.) Select the type of distribution provided by the external analysis method.
 - e.) Click **OK**.
6. Click **Next>>**.
 7. In the **Drain and load options** group box, select one of the following
 - **Prepare SediGraph to load sample** - select if the sample has not been loaded into the mixing chamber. If selected, a drain and load operation is performed.
 - **Leave liquid in mixing chamber / Leave mixing chamber empty** - select if the liquid should remain in the mixing chamber or leave the mixing chamber empty.

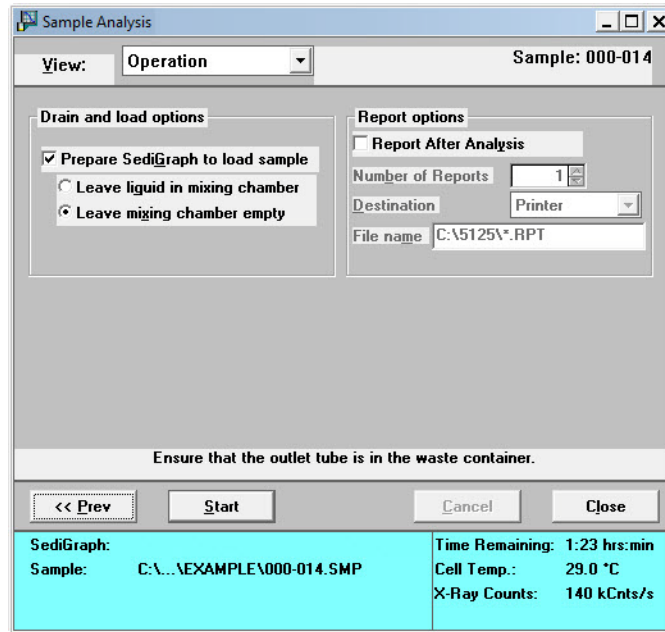

If...	Then
A sample is loaded into the mixing chamber	a.) Ensure that Prepare SediGraph to load sample is deselected. b.) Select report output options in the Report options group box. c.) Click Start .

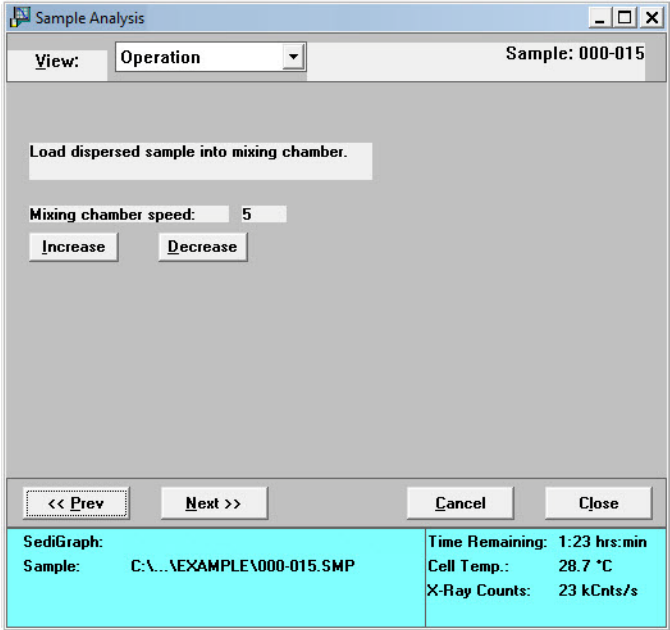
If...	Then (continued) (continued)
<p>If a sample is not loaded</p>	<p>a.) Select Prepare SediGraph to load sample.</p> <p>b.) Select to have liquid remain in the mixing chamber or to have the chamber left empty.</p> <p>c.) Select report output options in the Report options group box.</p> <p>d.) Click Start. A drain operation is performed and the following window displays.</p>  <p>e.) Load the sample. To change the mixing chamber speed, use the Increase or Decrease button.</p> <p>f.) Click Start.</p>

8. Confirm the X-ray intensity reduction over the baseline before it completes:

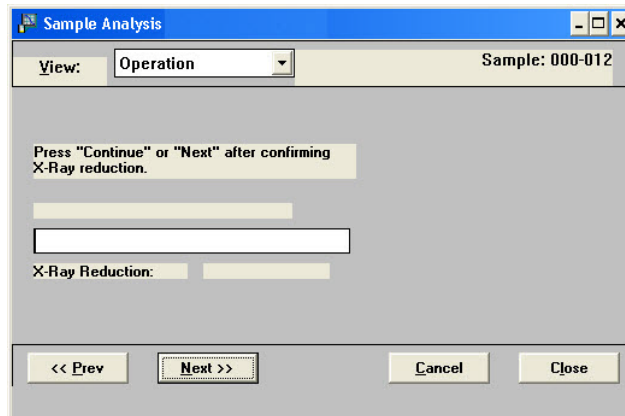

- **Good** - indicates reduction is between 30 and 75% meaning that the concentration level is appropriate.
- **Low** - indicates the reduction is less than 30% meaning that the concentration is too low and sample should be added.
- **High** - indicates the reduction is more than 75% meaning that the concentration is too high and more dispersant or less sample should be used.

9. When satisfied with the concentration level, click **Next >>**.



If rinse after analysis is not specified, select the Rinse after analysis option any time while the analysis is in progress.

10. The **Load operation in progress** window followed by a dual-paned window. The left pane contains the current baseline and full-scale scan. The right pane contains analysis data in progress.

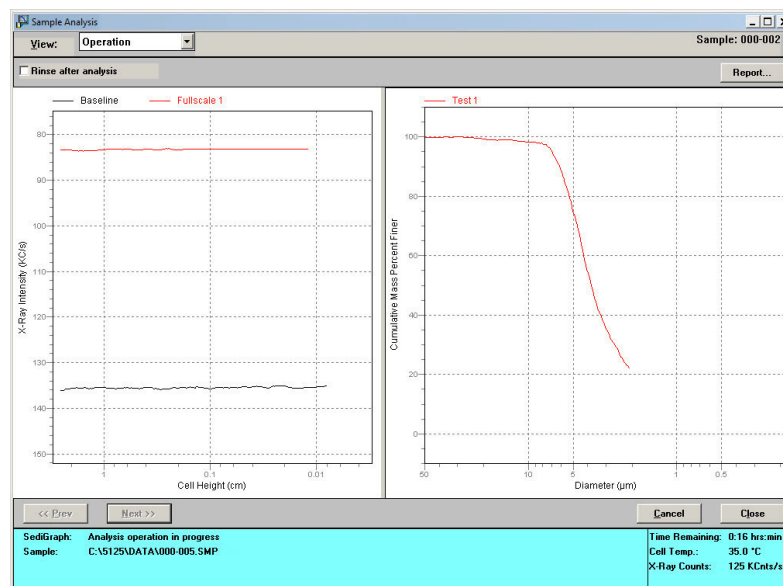

Quick Start Analysis

Unit [n] > Quick Start

To perform analyses on multiple samples using the same analysis conditions.

1. Go to *Unit [n] > Quick Start*.

2. If the analyzer has not been drained, select **Prepare SediGraph to load sample** to drain the mixing chamber. Then select to have the liquid remain in the mixing chamber after the drain and load operation or to leave the mixing chamber empty.
3. Click **Report After Analysis** to generate a report after analysis is complete. Select the destination and specify the number of copies to print.
4. To specify a different identification string, enter a new name in the **Sample** field. To have the sample file number included as part of the identification, the \$ symbol must remain in the field.
5. Click **Next>>**. If **Prepare SediGraph to load sample** was selected, a drain is performed before being prompted to load the first sample..



To analyze a sample requiring different analysis conditions, click Browse and select the different sample file. Once this sample is completed, all conditions revert back to the ones established for the Quick Start series.

6. Load the sample. To change the mixing chamber speed, use the **Increase** or **Decrease** button.

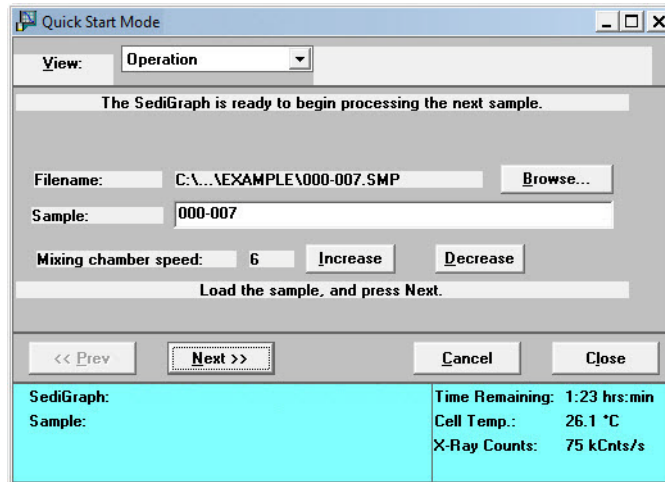

7. Click **Next>>**. Analysis of the first sample begins. The current baseline and data display as they are collected

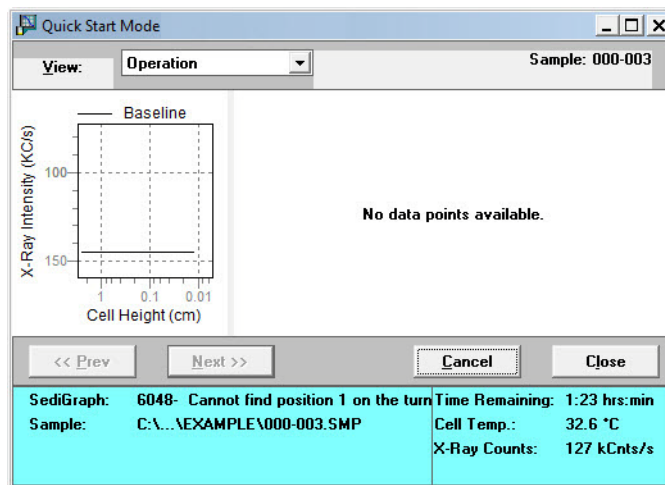

Panes may be resized using standard Windows resizing functions.

8. When analysis is complete, a prompt to load the next sample displays. Repeat steps 6 and 7 until all analyses are complete.

Repeat Schedule

Unit [n] > Repeat Schedule

To perform multiple analyses on the same sample:

1. Go to *Unit [n] > Repeat Schedule*.

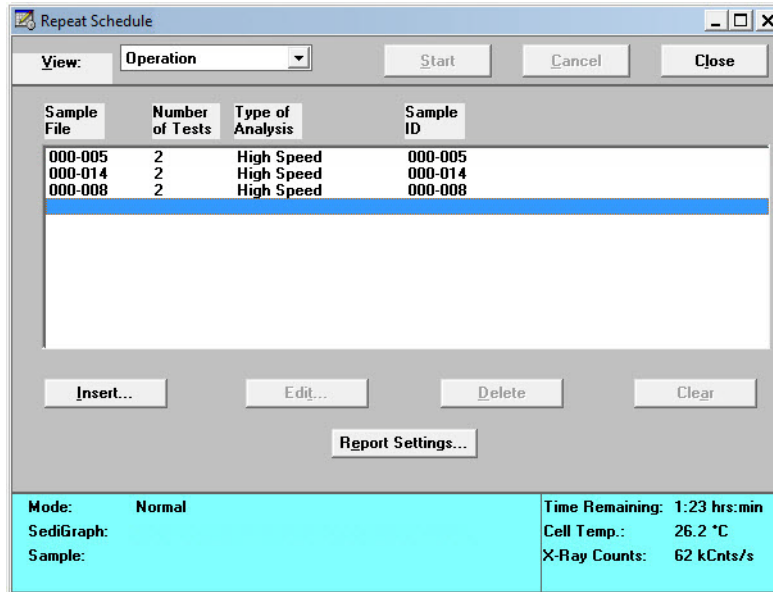

2. Click **Insert**.

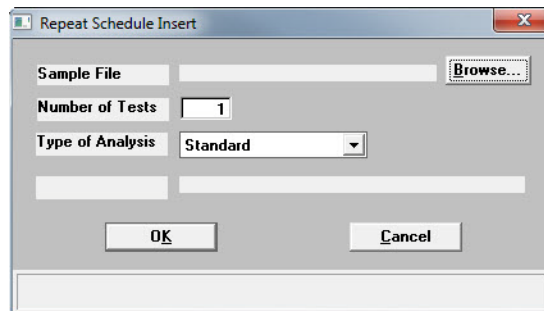

- a.) Click **Browse** to select a sample file to use for analysis.
 - b.) Enter the number of tests (analyses) to perform.
 - c.) Select the **Type of Analysis** in the dropdown list.
 - d.) Click **OK**.
 - e.) Repeat this step for all analyses to be performed using this sample.
3. To edit a parameter file, highlight the file and click **Edit**.

- Click **Report Settings** to generate a report after analysis. Select the destination and specify the number of copies to print.
- Click **Start** to begin the analyses.



When the analysis begins, the Start button changes to Stop. The Stop button cancels the remaining analyses. The analysis that is currently in progress will be completed.

MasterTech Automatic

Unit [n] > MasterTech Automatic



This option is functional only if a MasterTech is connected to the analyzer.

Use to analyze a series of samples of the same type, using the same analysis conditions. Sample files containing the default analysis conditions are created automatically and used for all analyses.

- Go to *Unit [n] > MasterTech Automatic*.

- In the **Start with beaker** field, enter the position number of the beaker containing the first sample to be analyzed.
- In the **Sample resuspension** group box, enter the stirrer time, stirrer speed and probe time to use for sample resuspension. Samples tend to settle in the beaker while waiting for analysis, especially if samples are prepared ahead of time. This option allows samples to be redispersed

before analysis. Coarse materials and less stable dispersions may need a higher speed and more stirring and probe time than finer samples.

4. Select **Report After Analysis** to generate a report after analysis. Select the destination and specify the number of copies to print.
5. In the **Sample** field, enter a default string for this series of samples.



The beaker number containing the sample can be included in the sample identification by entering # within the specified name. For example, *Garnet in beaker #*.

6. Click **Start**.



When the analysis begins, the Start button changes to Stop. The Stop button cancels the remaining analyses. The analysis that is currently in progress will be completed.



To view the analyses in progress, select Analysis Results from the View dropdown list.

MasterTech Schedule

Unit [n] > MasterTech Schedule

Use to analyze a series of samples that are different in size and shape and require different analysis conditions. Baseline measurements can be scheduled between samples.

1. Go to *Unit [n] > MasterTech Schedule*.

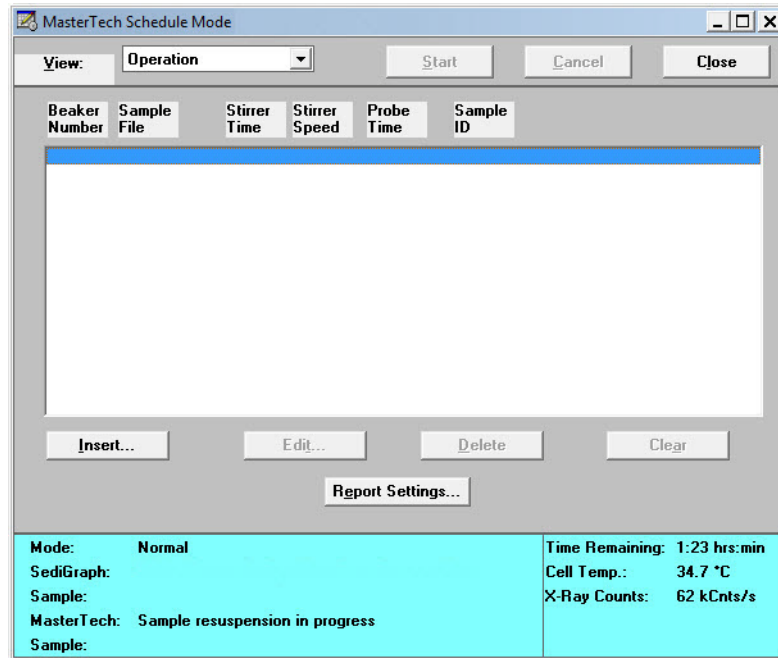

2. Click **Insert**.

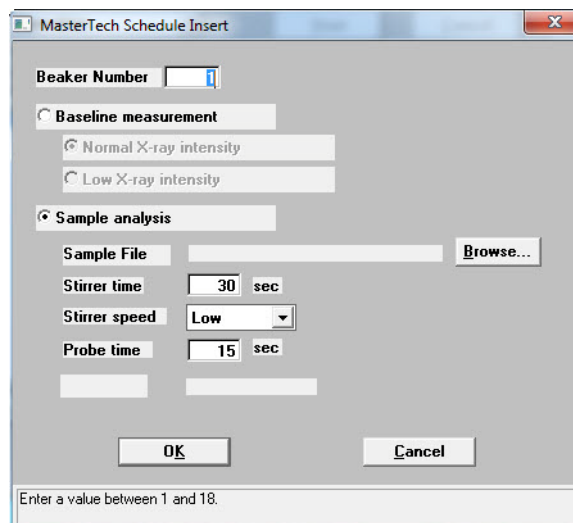

- a.) Enter the position number of the beaker containing the current sample.

b.) Select **Baseline measurement** or **Sample analysis**.

- If **Sample analysis** is selected, click **Browse** to select a sample file to use with the sample in this beaker position. The values contained in the fields for **Stirrer time**, **Stirrer speed**, and **Probe time** are copied from the selected sample file.
- If **Baseline measurement** is selected, select the X-Ray intensity.
 - **Normal** - increases intensity when using high X-ray absorption liquids, such as water.
 - **Low** - decreases intensity when using low X-ray absorption liquids, such as hydrocarbons.

c.) Click **OK**. The beaker information displays in the list box.

d.) Repeat this step for each beaker containing sample.

If dispersing liquids will be changed at any time during this series, perform a baseline measurement using the beaker position preceding the one containing the sample with the new liquid. For example, if dispersing liquids are changed with the sample contained in beaker position 4, insert a Baseline measurement for beaker position 3.

3. Click **Report Settings** to generate a report after analysis. Select the destination and specify the number of copies to print. Click **OK**.
4. Click **Start** to begin the analysis.



When the analysis begins, the Start button changes to Stop. The Stop button cancels the remaining analyses. The analysis that is currently in progress will be completed.



To view the analyses in progress, select Analysis Results from the View dropdown list.

Performing a Rinse Operation

Unit [n] > Rinse > [SediGraph, MasterTech, Both]

A rinse operation should be performed to rinse any debris or contaminants from the analysis cell. It is best to perform a rinse operation after each analysis. On the **Analysis Options** window, select that a rinse is to be performed after an analysis. Refer to **Analysis Conditions**, page 2-8.

- **SediGraph** - rinses the analysis cell, mixing chamber, and tubing
- **MasterTech** - rinses the MasterTech tubing into a specified beaker
- **Both** - rinses the analysis cell, mixing chamber, and *all* tubing



The rinse container should be rinsed thoroughly or replaced after each use.

Rinse SediGraph

Unit [n] > Rinse > SediGraph

The following steps rinse the analysis cell, mixing chamber and tubing.

1. Pour approximately 10 liters of water containing a small amount of surfactant into the rinse container. For example, use 0.05% sodium metaphosphate (W/W) in deionized water.
2. Insert the rinse tube into the rinse container. Insert the waste and overflow tubes into the waste container. Turn the caps clockwise to secure.

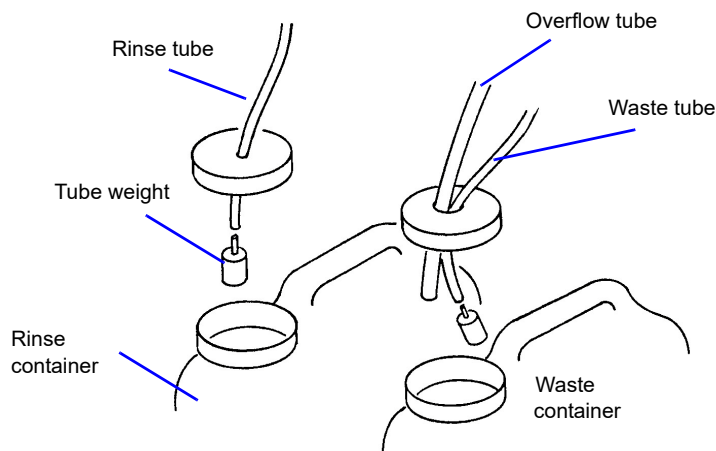

Ensure that tube weights are attached to the rinse and waste tubes, that the overflow tube and waste tubes are in the waste container, and that the rinse tube is in the rinse liquid container.

- Go to *Unit [n] > Rinse > SediGraph*.

SediGraph Rinse

Autorinse
 Rinses 3

Cell Pump Speed 4

Ensure that the outlet tube is in the waste reservoir.
Ensure that the rinse tube is in the rinse liquid reservoir.

Continue Cancel

SediGraph: Cell Temp.: 33.4 °C
X-Ray Counts: 114 kCnts/s

- Select one of the following:
 - Autorinse** - to have the analyzer automatically determine how many rinse cycles to perform.
 - Rinses** - to specify the number of rinses. If **Rinses** is selected, enter the number of rinse cycles to perform.



Autorinse, in an effort to reestablish baseline conditions, performs three cycles of three rinses per cycle (default setting) before displaying an error message that baseline conditions cannot be reestablished.

- Enter the operating speed of the cell pump. A speed of 2 usually is sufficient unless the material is difficult to rinse; then it may be necessary to use a higher speed.
- Click **Continue**. Progress messages display until rinsing is complete.

Rinse MasterTech

Unit [n] > Rinse > MasterTech

Use to rinse the MasterTech tubing into a specified beaker.

1. Pour approximately 10 liters of water containing a small amount of surfactant into the rinse container. For example, use 0.05% sodium metaphosphate (W/W) in deionized water.
2. Insert the rinse tube into the rinse container. Insert the waste and overflow tubes into the waste container. Turn the caps clockwise to secure.

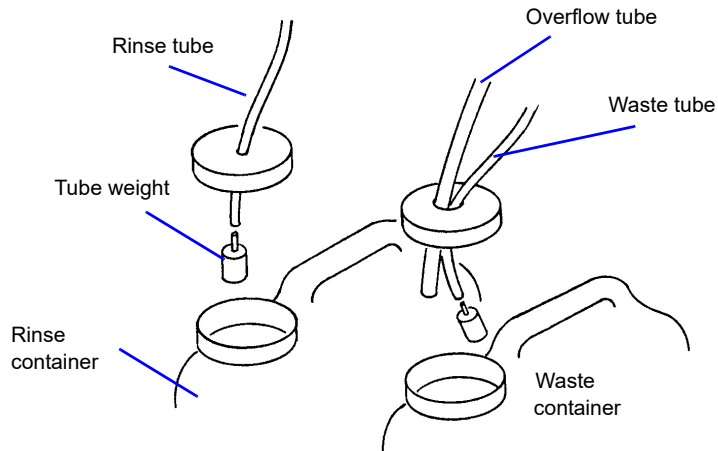

Ensure that tube weights are attached to the rinse and waste tubes, that the overflow tube and waste tubes are in the waste container, and that the rinse tube is in the rinse liquid container.

3. Go to *Unit [n] > Rinse > MasterTech*.

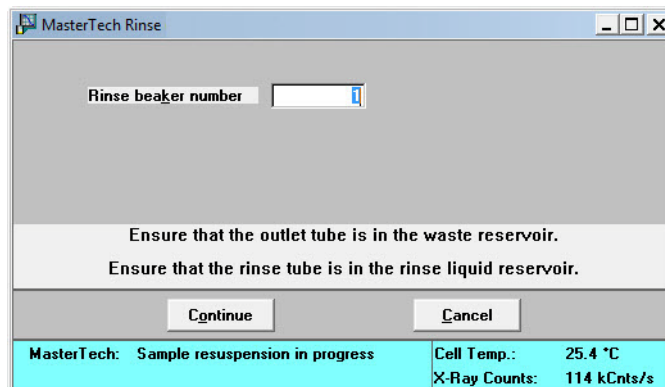

4. Enter the position number of the beaker to catch the rinse liquid. Ensure the beaker is empty.
5. Click **Continue**. Progress messages display until rinsing is complete.

Rinse Both

Unit [n] > Rinse > Both

To rinse the analysis cell, the mixing chamber, and the tubing for the analyzer and the MasterTech.

1. Pour approximately 10 liters of water containing a small amount of surfactant into the rinse container. For example, use 0.05% sodium metaphosphate (W/W) in deionized water.
2. Insert the rinse tube into the rinse container. Insert the waste and overflow tubes into the waste container. Turn the caps clockwise to secure.



Ensure that tube weights are attached to the rinse and waste tubes.

3. Go to *Unit [n] > Rinse > Both*.

SediGraph and MasterTech Rinse	
SediGraph <input checked="" type="radio"/> Autorinse <input checked="" type="radio"/> Rinse <input type="text" value="3"/> Cell Pump Speed <input type="text" value="4"/>	MasterTech Beaker number <input type="text" value="1"/>
Ensure that the outlet tube is in the waste reservoir. Ensure that the rinse tube is in the rinse liquid reservoir.	
<input type="button" value="Continue"/> <input type="button" value="Cancel"/>	
SediGraph: MasterTech: Sample resuspension in progress	
Cell Temp.:	34.8 °C
X-Ray Counts:	101 kCnts/s

4. In the **SediGraph** group box, select one of the following:
 - **Autorinse** - to have the analyzer automatically determine how many rinse cycles to perform.
 - **Rinse** - to specify the number of rinses. If **Rinse** is selected, enter the number of rinse cycles perform.
5. In the **MasterTech** group box, enter the beaker position number to catch the rinse liquid. Ensure the beaker is empty.
6. Click **Continue**. Progress messages display until rinsing is complete.

Generating Reports

Reports > Start Report (or use the F8 keyboard shortcut)

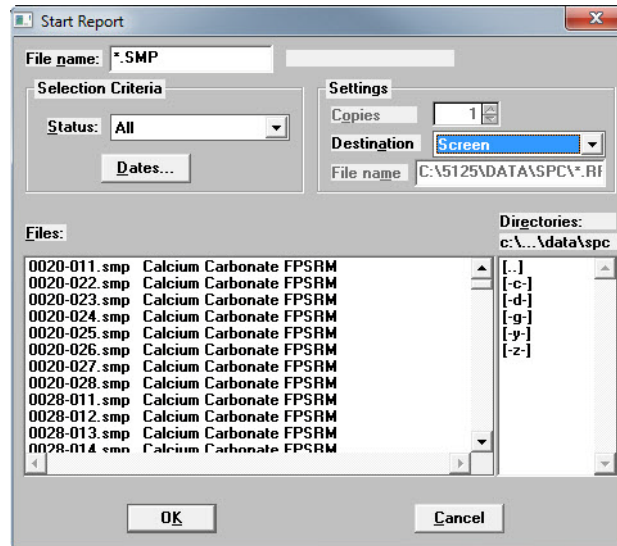

1. Select a sample file. The selected report name appears in the **File name** text box. To select multiple files, hold down the **Ctrl** key on the keyboard while selecting the files, or hold down the **Shift** key to select a range of files.
2. Select a destination in the **Settings** group box. Refer to **Print Options** in [Common Fields and Buttons - File Menu Options](#), page 3-1. Click **OK**.
3. If only one file was selected in Step 1, the **Reports to Generate** window displays. Verify the reports to generate and select additional reports if necessary. Click **OK**. If multiple files were selected, this window does not display.

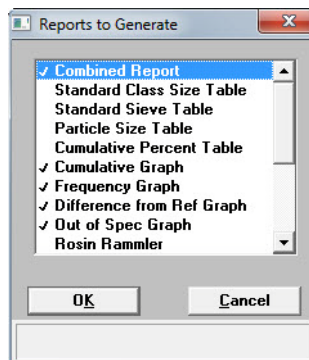

- To view the reports, click the tab across the top of the window.

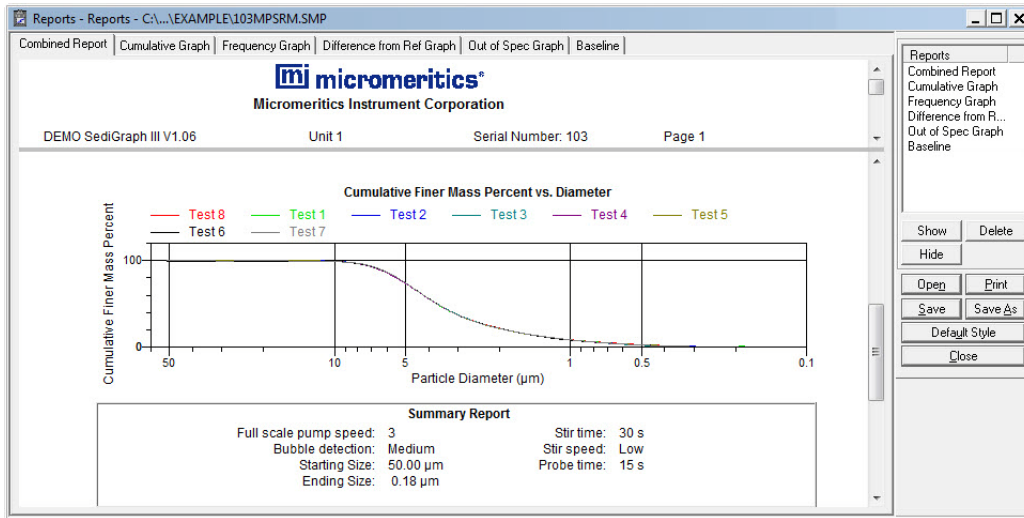

Status Display

All operational windows contain two common status displays; one in the upper portion of the window and one in the lower portion. Some status displays may contain more items than others, depending on the type of operation in process. The center portion of the window contains the activity of the current operation.

Go to *Unit [n]* > *Show Status* to display the status of the current operation.

Upper Display Items

The following is a typical upper status display.

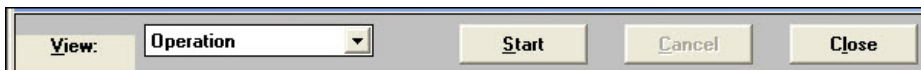

Lower Display

The following is a typical lower status display.

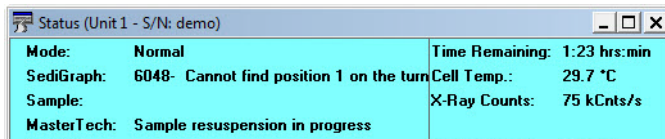

Printing Files

File > Print > [file type]

Prints the entire contents of a file. Select from:

- Sample information
- Analysis conditions
- Liquid properties
- Report options

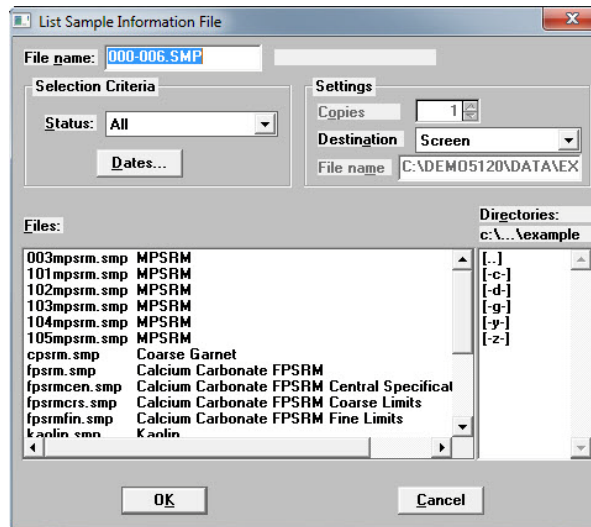

Field or Button	Description
<i>File name</i>	Displays the name of the selected file.
<i>Files</i>	<p>If the file(s) to be printed resides on a drive other than where the software is installed, select another drive in the Directories list box.</p> <p>Select one or more files from the Files list box. To select multiple files, hold down the Ctrl key on the keyboard while selecting the files, or hold down the Shift key to select a range of files.</p>
<i>Status</i>	Used as a filter to display only the files with the selected status.
<i>Dates button</i>	Used as a filter to display only the files within the selected date range.

Field or Button	Description (<i>continued</i>)
<i>Settings group box</i>	<ul style="list-style-type: none"> • Copies - specify the number of copies to print or display • Destination - specify screen, printer, or plotter as the print destination. Go to <i>Options > System Configuration</i> to configure the printer or plotter name. • File Name - enabled only if File is selected in the Destination field.

Exporting Files

File > Export > [file type]

Data in a sample information file can be exported as:

- **Smoothed ASCII** - exports data in a form used in reports
- **Raw ASCII** - exports as time, height, and mass fraction
- **Unsmoothed ASCII** - exports data as collected by the instrument. Refer to **DATA REDUCTION**, page **J-1** for information on the smoothing technique.

1. Go to *File > Export*.

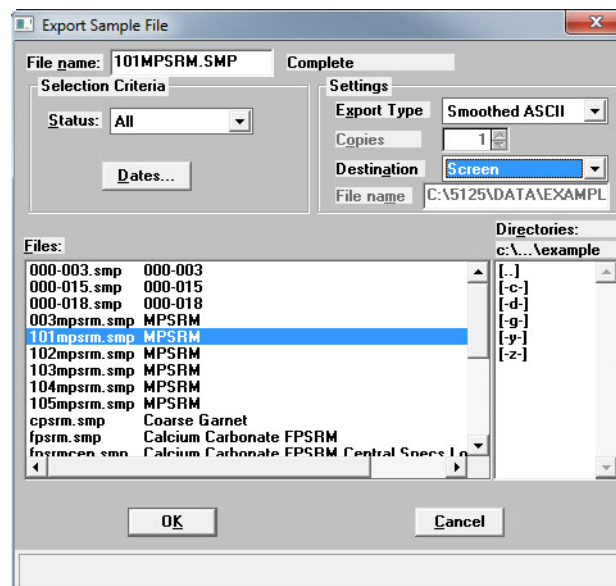

2. Select a file from the list. To select multiple files, hold down the **Ctrl** key on the keyboard while selecting the files, or hold down the **Shift** key to select a range of files. Click **OK**.

3. From the **Destination** dropdown list, select a list output destination. If **File** is selected, enter a name in the **File name** field.
4. Click **OK**. A list for the selected files is sent to the specified destination.

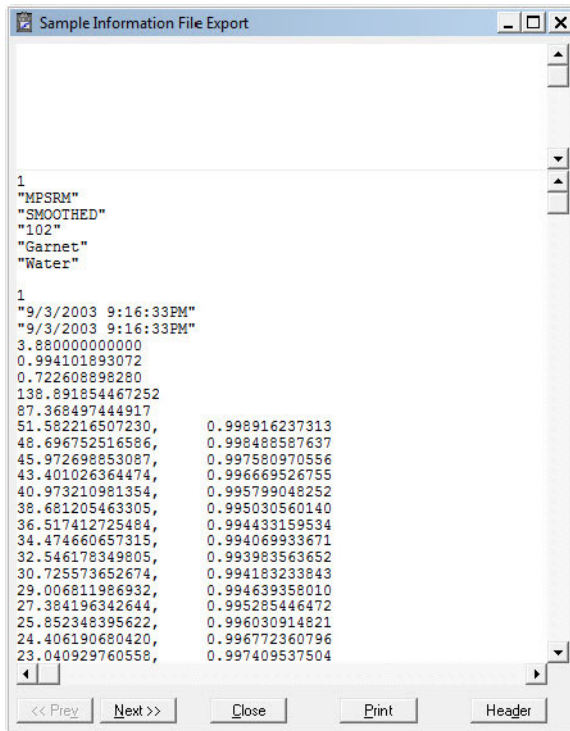

Listing Files

File > List > [file type] > [file]

Provides the option to create a list of sample file information, for example, file name, date, time the file was created or last edited, file identification, and file status.

1. Go to *File > List > [file type]*.

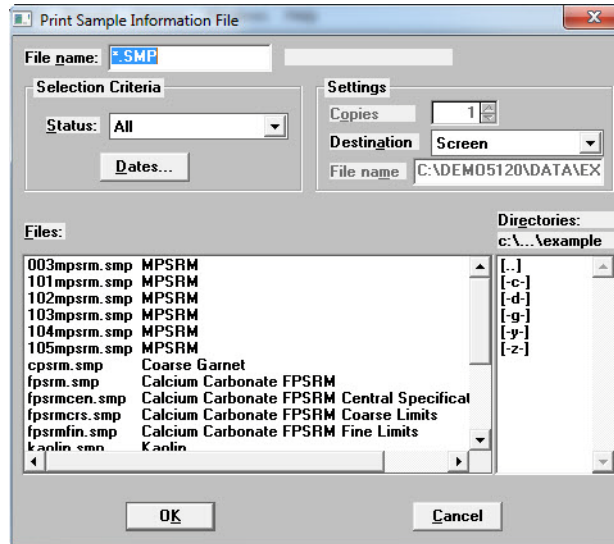

2. Select a file from the list. To select multiple files, hold down the **Ctrl** key on the keyboard while selecting the files, or hold down the **Shift** key to select a range of files.
3. From the **Destination** dropdown list, select a list output destination. If **File** is selected, enter a name in the **File name** field.
4. Click **OK**. A list for the selected files is sent to the specified destination.

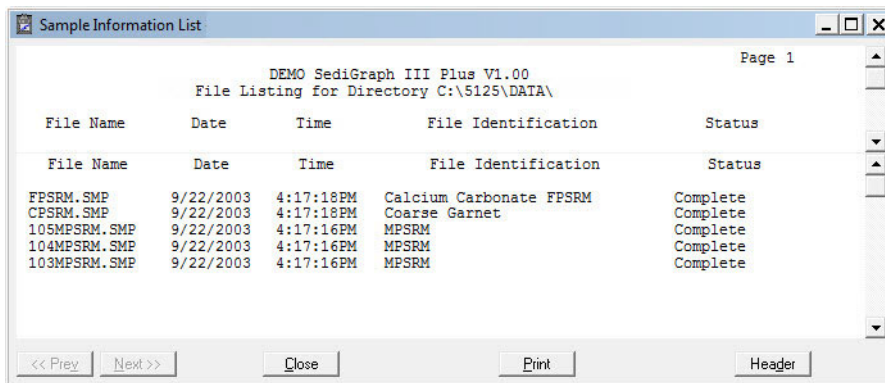

Converting Non-Windows Sample Files

File > Convert [file]

Converts sample information files created with the non-Windows version of the SediGraph analysis program to a file that is compatible with Windows.

After conversion, the converted file and associated parameter files can be used with any analysis as long as the analysis has not been completed. Material properties cannot be updated.

1. Go to *File > Convert*.

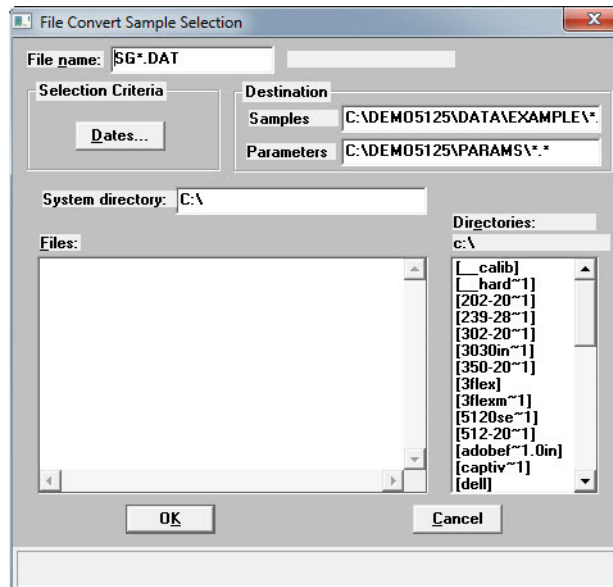

2. Using the **Directories** list box, navigate to the location where the non-Windows data files are stored.
3. From the **Files** list box, choose the files to convert. To select multiple files, hold down the **Ctrl** key on the keyboard while selecting the files, or hold down the **Shift** key to select a range of files.



To filter the files by date, click Dates and specify a date range.



As sample files are converted, the referenced liquid properties and user-defined report tables are also converted. The Parameters field gives the destination for the converted parameter files.

4. In the **System directory** field, enter the source directory of the non-windows parameter files.

Two types of parameter files are associated with a non-Windows sample file: Liquid Properties and User-Defined Report Tables. These files are required for a complete conversion. If a directory

is not entered, the conversion proceeds but all files may not be found. A warning message is displayed in the **Status** window if parameter files are not found.

If converting files on the same computer where the files were created, the files are located automatically. If converting files created on a different computer, place a copy of the file(s) from the other computer onto the computer running the conversion. A warning message is displayed in the Status window if all parameter files are not found

5. Click **OK**. The status of the conversion displays. If the conversion was unsuccessful, possible reasons are given.



To stop the conversion, click Close. To close the status window, go to the system menu in the upper left corner and click Close or use the keyboard command of Ctrl+F4.

Exit

File > Exit

Exits the program.

- If changes have been made to a file and not yet saved, a prompt displays providing the option to save the file.
- If a file is open with unsaved changes, a prompt displays providing the option to exit the program.

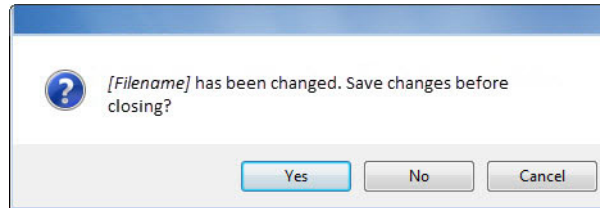

- **YES** saves the changes before exiting the program
- **NO** exits the file without saving the changes
- **CANCEL** cancels any changes



If the MasterTech is being used, the current analysis continues until it is finished; subsequent analyses are postponed and resumed when the analysis program is restarted.



Although data are stored in the analyzer exiting the program, data are not saved to disk in the computer until the program is reopened. If a power failure occurs and the analyzer does not have an Uninterruptible Power Supply (UPS), any data not saved are lost.

- If a report is being printed, the following message is displayed:

CAUTION: A report is currently printing. If you exit the program the report will be canceled. Do you want to cancel the report and exit the program?

- **YES** cancels the report and exists the analysis program
- **NO** leaves the analysis program active and allows the reports to finish

Generating Overlays

Use the overlay function to compare multiple graphs. Overlays may be generated in three ways:

- from the same sample file to overlay multiple graphs.
- from multiple sample files to overlay the same type of graph(s).
- from the same sample file to overlay the same type of graph for all analyses (tests) used in this sample file.

It is much easier to generate overlays if predefined report options files were created for specific overlay functions. For example, **Out of Specification** graphs if compared often, define a report options file containing the options and assign an identification such as **Out of Spec Overlays**. Then use **Replace** to load the predefined file into the sample file. Report options for the original sample file remain intact.

Overlay Multiple Graphs from the Same Sample File

1. Go to **File > Open > Sample information**.

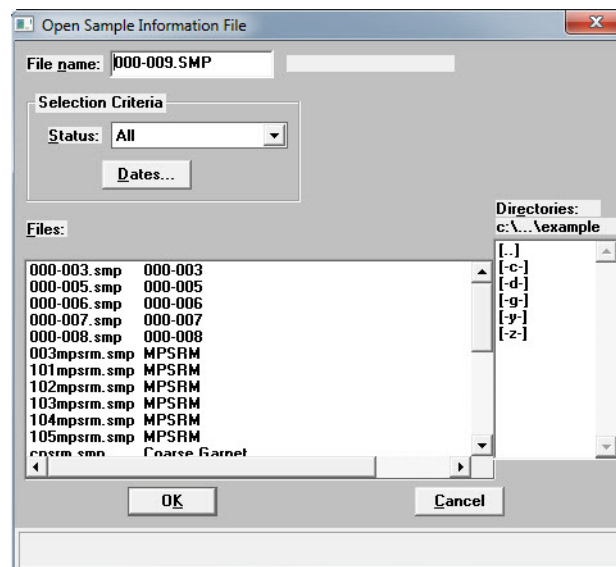

2. Select the file and then click **OK**. If an **Advanced** button displays at the bottom of the popup window, click **Advanced** to change to **Advanced** view.

3. Select the **Report Options** tab.

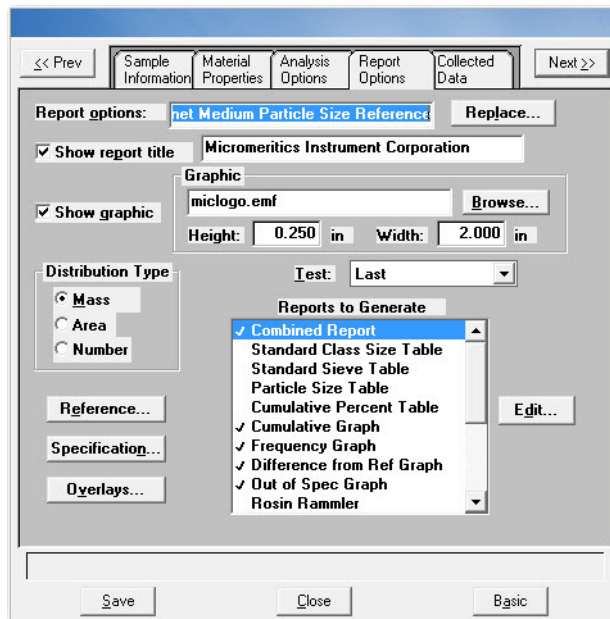

4. Use one of the following methods:

If...	Then...
Using a predefined Report Options file	Click Replace and select the report options file to use.

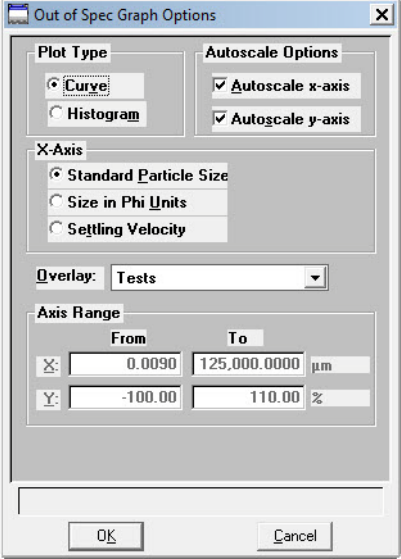
If...	Then... (continued)
<p>Defining report options</p>	<p>a.) In the Test dropdown list, select the test to use.</p> <p>b.) In the Reports to Generate list box, select the graph(s) to overlay with other graph(s). To select a graph, double-click the graph name. A checkmark to the left indicates the graph has been selected.</p> <p>c.) Highlight a graph selected in Step 4.b) and click Edit.</p> <div style="text-align: center;">  </div> <p>d.) From the Overlay dropdown list, choose the type of graph to overlay; then click OK.</p> <p>e.) Repeat Steps 4.c.) and 4.d.) for each selected graph.</p>



The options do not have to be saved before generating overlay reports. If they are saved, the original report options will be overwritten.

5. Go to *Reports > Start report*.
6. Select a destination in the **Settings** group box. Refer to **Print Options** in **Common Fields and Buttons - File Menu Options**, page 3-1.
7. Click **OK**. Report options can be changed on the **Reports to Generate** list box.
8. Click **OK**. Selected overlays are generated and sent to the specified destination.

Overlay the Same Graph Type for Multiple Sample Files

1. Go to **File > Open > Sample information**.

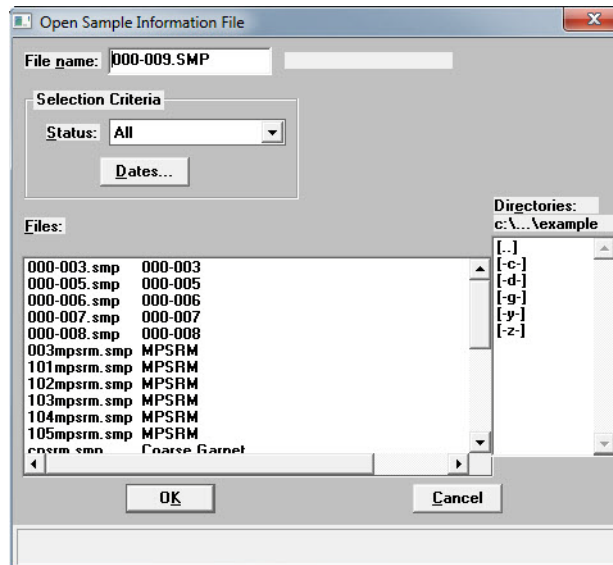

2. Select the file and then click **OK**. If an **Advanced** button displays at the bottom of the popup window, click **Advanced** to change to **Advanced** view.
3. Select the **Report Options** tab.

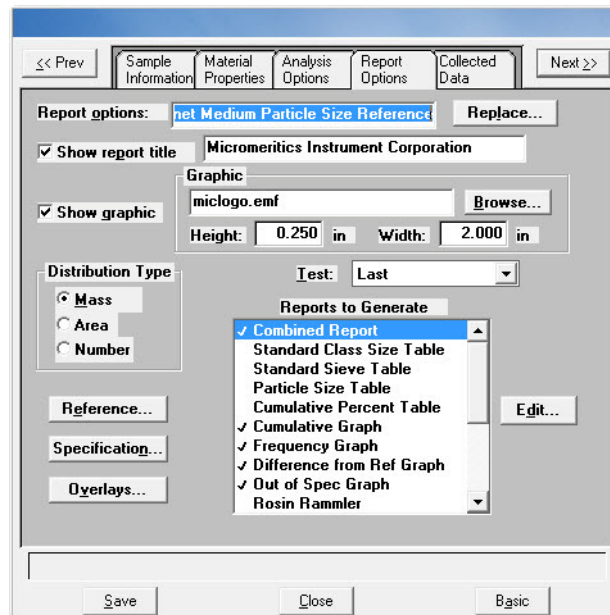

4. Use one of the following methods:

If...	Then...
Using a predefined Report Options file	Click Replace and select the report options file to use.
Defining report options	<p>a.) In the Test dropdown list, select the test to use. The graph(s) selected for this report will be overlaid with the corresponding graph(s) of the test designated in the Report Options file(s) of the sample file(s) selected in step 7.</p> <p>b.) In the Reports to Generate list box, select the graph(s) to overlay. To select a graph, double-click the graph name. A checkmark to the left indicates the graph has been selected.</p> <p>c.) Highlight a graph selected in Step 4.b.) and click Edit.</p> <div data-bbox="794 810 1187 1367" data-label="Image"> </div> <p>d.) From the Overlay dropdown list, select Samples. Click OK.</p> <p>e.) Repeat Steps 4.c.) and 4.d.) for each selected graph.</p>

- Click **Overlays**.

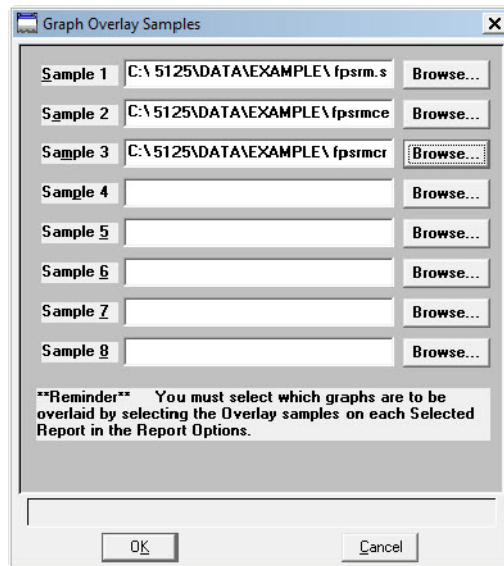

- Click **Browse** to select the sample information files.

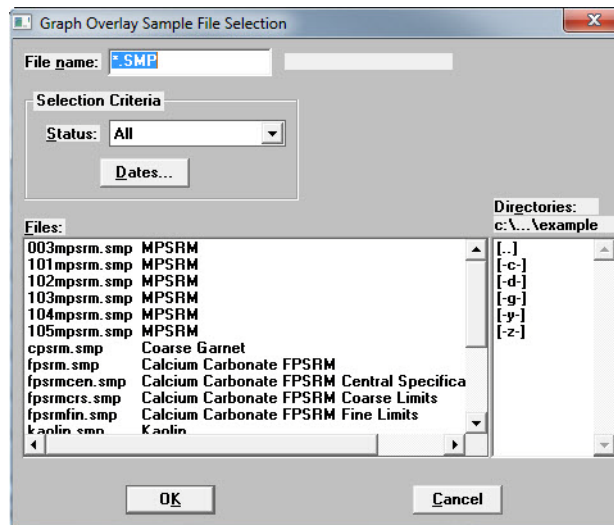

- Select up to eight files and click **OK**.



The options do not have to be saved before generating overlay reports. If they are saved, the original report options will be overwritten.

- Go to **Reports > Start report**.
- Select a destination. Refer to **Print Options** in **Common Fields and Buttons - File Menu Options**, page 3-1.
- Click **OK**.

Overlay the Same Type of Graph from the Same Sample File

1. Go to **File > Open > Sample information.**

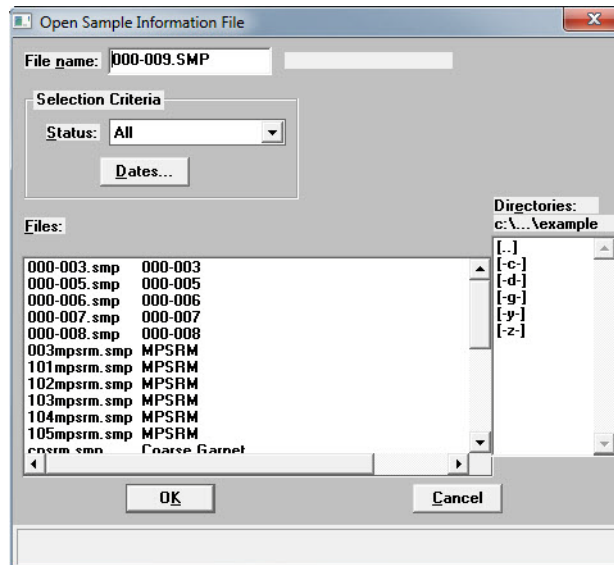

2. Select the file and then click **OK**. If an **Advanced** button displays at the bottom of the popup window, click **Advanced** to change to **Advanced** view.
3. Select the **Report Options** tab.

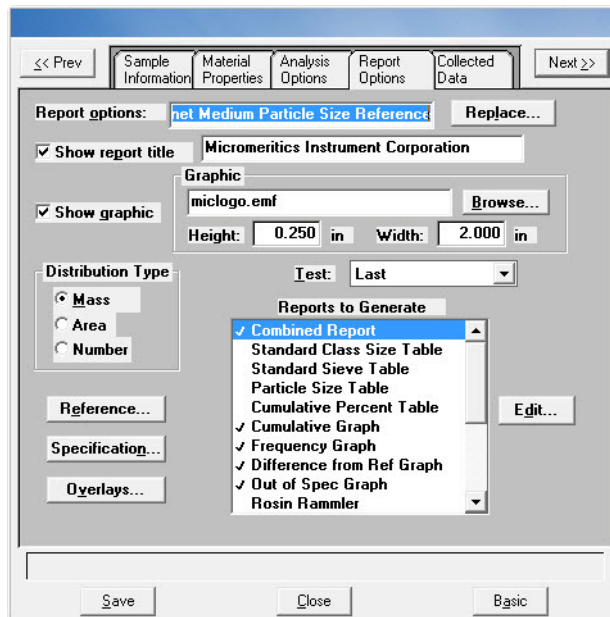

4. Use one of the following methods:

If...	Then...
Using a predefined Report Options file	Click Replace and select the report options file to use.
Defining report options	<p>a.) In the Reports to Generate list box, select the graph(s) to overlay. To select a graph, double-click the graph name. A checkmark to the left indicates the graph has been selected.</p> <p>b.) Highlight a graph selected in Step 4.b.) and click Edit.</p> <div data-bbox="889 638 1289 1199" data-label="Image"> </div> <p>c.) From the Overlay dropdown list, select Tests. Click OK.</p> <p>d.) Repeat Steps 4.b.) and 4.c.) for each selected graph.</p>



The options do not have to be saved before generating overlay reports. If they are saved, the original report options will be overwritten.

- Go to **Reports > Start report**. The sample information file selected in step 2 will be highlighted in the **Files** list.
- Select a destination. Refer to **Print Options** in **Common Fields and Buttons - File Menu Options**, page 3-1.
- Click **OK**.

3. FILE MENU

Introduction

This chapter contains information specific to the File menu options used in sample and parameter files. This chapter provides details of File menu options, commonly used functions and buttons, and field descriptions.

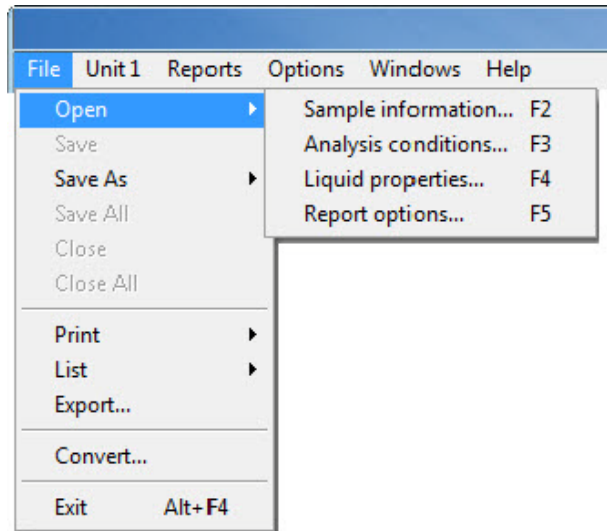

Common field and button descriptions are listed in a Common table at the beginning of their respective chapters. Field and button descriptions not listed in the Common table are listed in their appropriate heading.

Common Fields and Buttons - File Menu Options

The following fields and buttons are common to many of the File Menu windows. Field and button descriptions not listed below are found in their respective sections.

Field or Button	Description
<i>Advanced button</i>	Click to change to Basic option presentation format.
<i>Autoscale checkbox</i>	When enabled on report parameters screens, allows the x- and y-axes to be scaled automatically. Autoscale means that the x- and y- ranges will be set so that all the data is shown. If Autoscale is not selected, the entered range is used.
<i>Axis Range</i>	On report parameters screens, the From / To fields are enabled when Autoscale options are not selected. Enter the starting and ending values for the x- and / or y-axes.

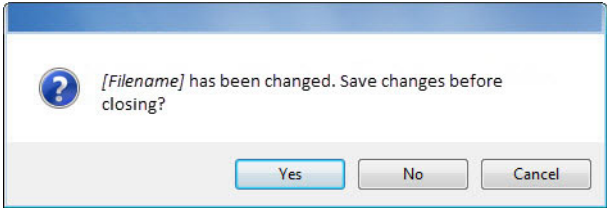
Field or Button	Description (<i>continued</i>)
Basic button	Click to change to Advanced option presentation format.
Browse button or icon	Click to search for a file. Select a file from either the Name column or from the library and click Open or double click the file name to open (or import) the file.
Cancel button	Cancels any changes made to the screen.
Close	Closes the active window. If changes were made to the file and not yet saved, a prompt displays providing the option to save the file.
Close All	<p>Closes all active windows. If changes were made and not yet saved, a prompt displays for each changed file providing the option to save the file.</p> 
Convert	Converts a sample file created with a non-Windows version of the SediGraph analysis program to a file compatible with Windows.
Delete button	When working with report parameters screens, click Delete to remove the selected report. Deleted reports will have to be regenerated if deleted in error.
Edit button	When working with report parameters screens, highlight the item in the Selected Reports list box and click Edit to modify report details.

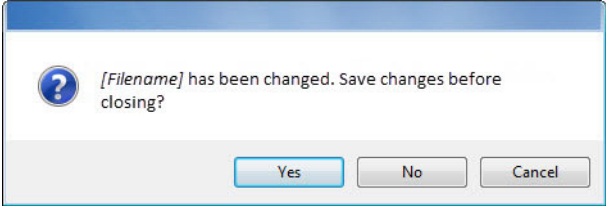
Field or Button	Description (<i>continued</i>)
<i>Exit</i>	<p>Exits the program.</p> <p>If a file is open with unsaved changes, a prompt displays providing the option to save the changes and exit or to exit the program without saving the changes.</p>  <ul style="list-style-type: none"> • Yes - saves the changes, then closes the window • No - closes the window without saving the changes • Cancel - cancels the Close command
<i>Export</i>	Exports isotherm data in a sample information file as a .REP, .TXT or .XLS file. When saved to a file, the data can be imported into other applications.
<i>File name text box</i>	Select a file from Files list box. The file name displays in the File name text box. Click Open or double-click the file name to open the file. To select multiple files, hold down the Ctrl key on the keyboard while selecting the files, or hold down the Shift key to select a range of files.
<i>From / To text boxes</i>	When working with report parameters screens, enter the From and To range for x- and / or y-axes.
<i>List</i>	Provides the option to create a list of sample or report options file information, for example, file name, date / time the file was created or last edited, file identification and file status.
<i>Name column</i>	A list of files in the selected directory or library.
<i>Next >></i>	Click to move to the next screen.
<i>OK button</i>	Click to save and close the active window.
<i>Open button</i>	Click to open the selected file (or double-click the file name in the Name column to open the file).
<< <i>Prev</i>	Click to move to the previous screen.

Field or Button	Description (<i>continued</i>)
<i>Print options</i>	<p>Sends the report to the selected destination (screen, printer or file).</p> <ul style="list-style-type: none"> • Preview - sends the file to the screen. Click Print on the report screen to send the file to the printer. • Print - sends the file to the default printer. • Copies - select the number of copies to print. This field is only enabled when Print is selected. • File - saves the report as a file. Click the Browse icon to the right of the text field to select the directory where the new file will be stored. Enter the new file name in the File name text box. • File Type - use to save the new file with a .TXT, .XLS or .REP file extension. This field is only enabled when File is selected. <p>.REP (Report system) - saves the report in a format that can be opened within any MicroActive program.</p> <p>.TXT (ASCII text) - saves the report as a text file.</p> <p>.XLS (Spreadsheet file) - saves the report in a format that can be opened within a spreadsheet program.</p>
<i>Remove</i>	Removes an item from a list.
<i>Replace button</i>	Click to select another file where the values will replace the current file's values.
<i>Save</i>	Saves the active window under the current file name.
<i>Save All</i>	Saves all active windows under the current file names.
<i>Save As</i>	<ul style="list-style-type: none"> • Saves a file in the active window under a different file name. • Saves a subset (parameter) of the sample file in the active window as a standalone parameter file. For example, to create a standalone parameter file of the analysis conditions portion of the active sample file, go to File > Save As, select the Analysis Conditions folder in the library and enter a file name in the File name field. Click Save.

Field or Button	Description (<i>continued</i>)
<i>Settings group box</i>	<ul style="list-style-type: none"> • Copies - specify the number of copies to print or display • Destination - specify screen, printer, or plotter as the print destination. Go to <i>Options > System Configuration</i> to configure the printer or plotter name. • File Name - enabled only if File is selected in the Destination field.
<i>Table buttons</i>	<ul style="list-style-type: none"> • Insert - inserts one row above the selected row. • Delete - deletes the selected row. • Clear - clears all table entries and displays only one default value. • Append - inserts one row at the end of the table.
<i>View Instrument Log</i>	For use by a Service Technician. Operators should use <i>Unit [n] > Show Instrument Log</i> . Refer to Show Instrument Log , page 4-30.

Open

Select **Open** to create a file or edit an existing one. The following file types are available:

- **Sample Information files** - the **File name** text box contains the next sequential sample information file name generated by the program. The sample information file extension is .SMP.
- **Parameter files** - the **File name** text box contains an asterisk (*) and a default file extension depending on the type of parameter file selected. Default file extensions are:

*.SMP	Sample Information
*.ANC	Analysis Conditions
*.LIQ	Liquid Properties
*.RPO	Report Options

Sample Information Files - Advanced Format

File > Sample Information > [file name]

Each analysis must be linked with a sample information file before the analysis can proceed. A sample information file can consist of parameter files, however, parameter files can also stand alone.

Parameter files allow repeated use of the file, for example, if the same analysis conditions exist for multiple analyses, create an Analysis Conditions file containing the recurring conditions. When the sample file is created, select the Analysis Conditions file for the analysis conditions. Once it becomes part of the new sample file, edit the new file as needed without affecting the original Analysis Conditions file. Sample Information files can be created or opened in Advanced, Basic, or Restricted format. Refer to [Creating Sample Files in Advanced Format](#), page 2-4 provides step-by-step instructions for creating a Basic sample information file.



Specify or change the default format by selecting *Options > Option Presentation* or select *Basic / Advanced* from the drop-down list at the bottom of the window. Refer to [Editing the Sample Default File](#), page 2-1 for a description of the Advanced, Basic, and Restricted formats.

Field or Button	Description
<i>Sample text box</i>	Enter a description of the sample.
<i>Operator / Submitter text boxes</i>	Enter identification information in the respective text boxes. Some text boxes may have been renamed or may not display if modified in <i>Options > Sample defaults</i> .

Field or Button	Description (<i>continued</i>)
<i>Type of Data group box</i>	<ul style="list-style-type: none"> • Automatically collected - select if the type of data will be automatically collected by the system while an analysis is running. • Manually entered - use to manually enter data collected from another source.
<i>User Parameters group box</i>	<p>These fields are primarily used for the SPC (Statistical Process Control) reporting to specify sample characteristics or its manufacturing process but may be used for other data by entering specific analysis conditions or sample criteria.</p> <p>The entered parameters display on the Sample Information window, in Reports > SPC Report Options, and the Summary Report.</p> <p>Choose to hide or display these fields or modify the default alphanumeric field labels in Options > Sample defaults.</p>
<i>Comments text box</i>	Enter comments about the sample or analysis. Comments display in the report header.
<i>Add Log Entry button</i>	Use to enter information to appear in the sample log report that cannot be recorded automatically through the application. Click the button again to enter multiple log entries.
<i>Replace All button</i>	Click to select another .SMP file where the values will replace all values for the active Sample Information file. The original file will remain unchanged.
<i>Close button</i> <i>Save button</i>	Refer to Common Fields and Buttons - File Menu Options , page 3-1

Sample Information Files - Basic Format

When in Basic format, all parts of the sample information file are contained on one window. With the Basic format, a sample information file can be quickly created using predefined parameter files. Refer to [Creating Sample Files in Basic or Restricted Format](#), page 2-6 provides step-by-step instructions for creating a Basic sample information file.

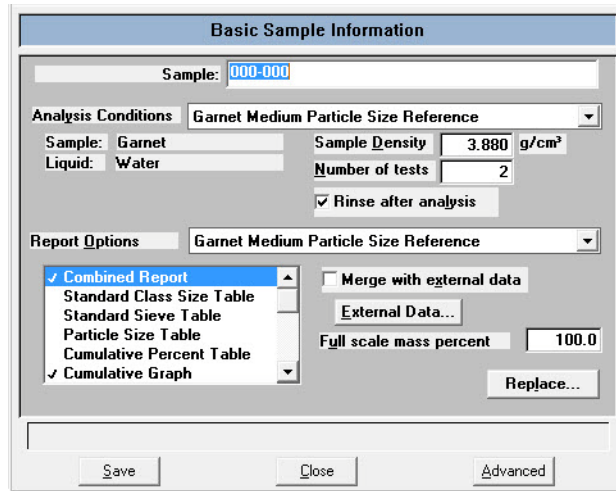

Field or Button	Description
<i>Sample</i>	Contains the next sequenced file description based on the format specified in Sample defaults.
<i>Analysis Conditions</i>	Displays a dropdown list containing analysis conditions files. This list is disabled for files which have been used for an analysis.
<i>Sample / Liquid</i>	Displays the type of sample and dispersing liquid used with the analysis conditions file selected in the Analysis Conditions dropdown list.
<i>Sample Density</i>	Displays the density of the sample specified in the Analysis conditions file. These properties may be edited on samples file not used in an analysis. If significant adjustments are required, switch to advanced format and define a new type of sample material.
 If the sample file is complete, density properties may be edited by selecting Advanced. Then select the Material Properties tab and Update Properties.	
<i>Number of tests</i>	Enter the number of analyses to perform with this sample file.

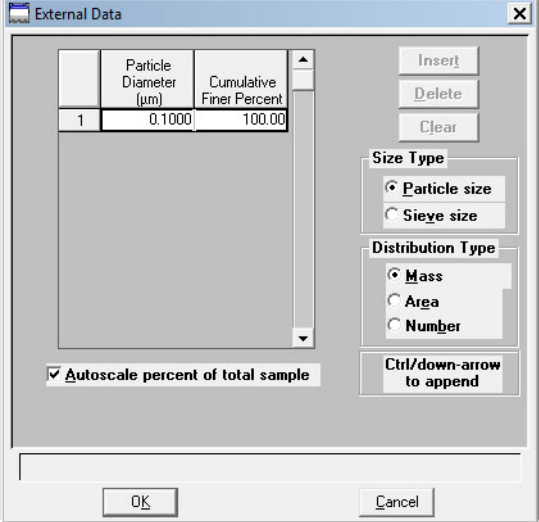
Field or Button	Description
<i>Rinse after analysis</i>	Select to rinse the cell, the tubing, and the mixing chamber after each analysis. It is highly recommended that this option remain selected. If deselected, rinses are not performed after analysis and inaccurate results may be obtained.
<i>Report Options</i>	Displays a dropdown list containing report options files.
<i>Reports list box</i>	Displays the specified reports from the file selected from the Report Options dropdown list.
<i>Merge with external data</i>	Select to merge data collected using manual methods with the data collected for the current analysis.
<i>External Data button</i>	<p>Enabled only if selected Merge with external data is selected. Allows the entering of data to be merged.</p>  <ul style="list-style-type: none"> • Insert - enter new data in the table. If this is a particle size table, enter the particle size and cumulative percent for the particle. If this is a sieve table, a set of sieves is displayed to enter the percent passed through each size. • Delete - removes the selected row from the table. • Clear - deletes all but one entry of the table (one entry is required).

Field or Button	Description
<p><i>External Data</i> button (continued)</p>	<ul style="list-style-type: none"> • Size Type - specify the type of size data. • Distribution Type - specify the type of distribution data. • Autoscale percent of total sample - When selected, the overlapping regions of the collected data and the merged data are used to rescale the collected data so that the regions match. <p>When deselected, the percentages entered for the merged data are used and the non-overlapping portion of the collected data is scaled to be the percent passing through the smallest sieve.</p>
<p><i>Full scale mass percent</i></p>	<p>Specify the weight percent of the sample actually analyzed by the analyzer versus the percent that is manually analyzed. The data are scaled accordingly.</p> <p>Use this option if part of the sample was analyzed by another method you do not want to merge those results with the reports for the current analysis.</p> <p>This field is disabled if <i>Merge with external data</i> is selected.</p>
<p><i>Close</i> button <i>Replace</i> button <i>Save</i> button</p>	<p>Refer to Common Fields and Buttons - File Menu Options, page 3-1.</p>

Analysis Conditions Files

File > Open > Analysis conditions > [file name] (or click the **Analysis Conditions** tab when in Advanced format)

Material Properties

The **Material Properties** tab specifies properties for the sample and analysis liquid.

Field or Button	Description
<i>Description</i>	Enter the description of the analysis conditions file.

Field or Button	Description (<i>continued</i>)
<i>Sample Material group box</i>	<p>Displays a list of available sample materials. When a sample material is selected, the description and density display.</p> <ul style="list-style-type: none">• Description - the selected sample material. Enter the name of sample materials to add to the list.• Density - the density of the sample material selected from the list.• Add - adds sample materials to the list. <p><u>To add samples materials</u> - in the Description field, enter the name of the sample material, then click Add.</p> <p><u>To change values of the sample material density</u> - highlight the sample material in the list, then enter the density value in the Density field.</p> <ul style="list-style-type: none">• Delete - deletes sample materials from the list.

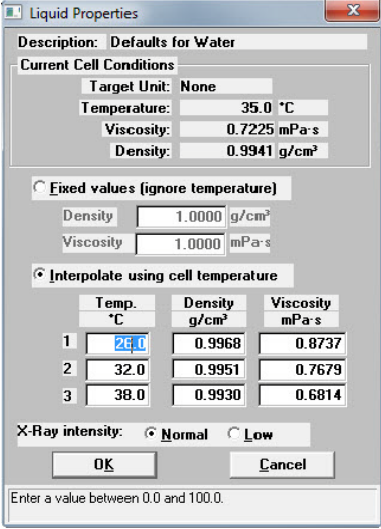
Field or Button	Description (<i>continued</i>)
<i>Analysis Liquid</i> group box	<p>Displays a list of the Liquid Properties files.</p> <ul style="list-style-type: none"> • Description - the selected analysis liquid. Enter the name of analysis liquids to add to the list. • X-Ray Intensity - the X-ray intensity selected for the analysis liquid. The intensity is selected in Liquid Properties window. • Add - adds analysis liquids to the list and change values for an analysis liquid. <p><u>To add analysis liquids</u> - in the Description field, enter the name of the liquid, then click Add.</p> <p><u>To change values of an analysis liquid</u> - highlight the liquid, then click Properties. Enter the new values, then click OK. Note that Add changes to Change; click Change.</p> <ul style="list-style-type: none"> • Delete - deletes the selected liquid from the list. • Properties button - edit the properties of the analysis liquid. Refer to Liquid Properties, page 3-21. 

Field or Button	Description (<i>continued</i>)
<i>Analysis Type</i>	<p>Specifies if the analysis is Standard, High Speed or High Resolution.</p> <ul style="list-style-type: none">• Standard - provides good resolution and average analysis time.• High speed - allows a faster analysis, but a little lower resolution.• High resolution - provides high resolution at the smallest diameters, but takes a longer time.• Starting diameter - specify the range of sizes to be included in the analysis. The starting diameter generally should be <i>larger</i> than the largest particle expected to be in the sample.• Ending diameter - the ending diameter must be <i>less</i> than the smallest size particle of interest. <p>Each time the values in these fields are changed, the analysis statistics are updated. A note also is added to the report header indicating changes have been made since the first analysis was performed.</p>

Field or Button	Description (<i>continued</i>)
<i>Analysis Unit</i>	<p>Displays a list of the attached units and their temperatures. The displayed temperature is used to compute analysis statistics.</p> <ul style="list-style-type: none"> • Reynolds number - calculated for the starting diameter using the sample's density and the liquid's density and viscosity. If this number is greater than 0.3, large particles falling through the liquid may create turbulence, affecting both their velocity and the velocity of neighboring smaller particles. This results in an incorrect particle size distribution. • Maximum diameter - calculated to have a Reynolds number equivalent to the one entered as a default (from the Options menu). If the sample has more than a couple percent mass of particles larger than this diameter, the sample should be analyzed in a liquid with a higher viscosity. • Analysis time - calculated based on the sample density, liquid density and viscosity, and ending diameter. The actual analysis time may vary slightly if the analysis compartment temperature is different when the analysis takes place. <p>The Reynolds number, Maximum diameter, and Analysis time fields display analysis statistics. These values are updated whenever a parameter affecting their computation is changed.</p>

Field or Button	Description <i>(continued)</i>
-----------------	--------------------------------

Update Properties button

Allows the updating of the material properties of a *completed* analysis. This allows the collected data to be reprocessed based upon the new properties.

The material properties for the original analysis remain unchanged. A note is added to the report header describing the change.

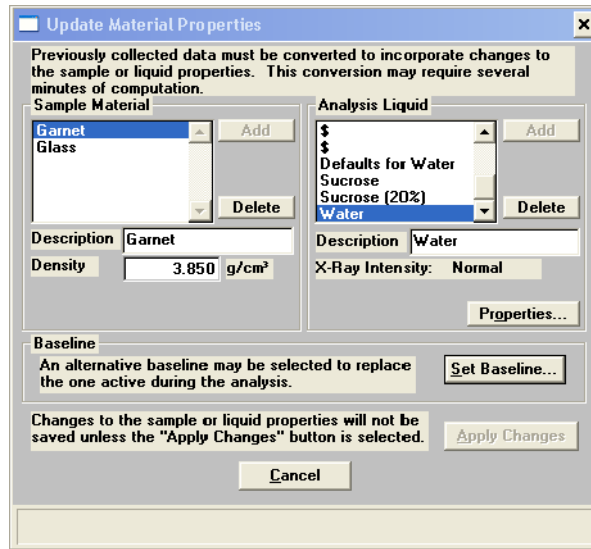

The contents of the **Sample Material** and **Analysis Liquid** group boxes are described in [Material Properties](#), page 3-11.

- **Set Baseline** - applies a baseline different than the one active in the original analysis.

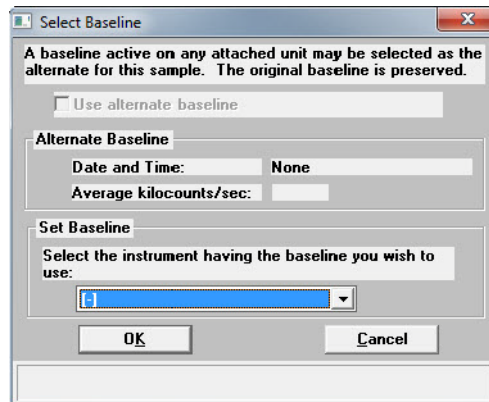

From the dropdown list, choose the instrument containing the baseline to use, then select **Use alternate baseline**. The original baseline is preserved.

Field or Button	Description <i>(continued)</i>
<i>Update Properties button (continued)</i>	<ul style="list-style-type: none">• Apply Changes button - select to apply all changes to the material properties. <p>Click Yes at the prompt - All test data will be converted to the new data reduction options. Do you wish to continue?</p> <p>The data are converted and this prompt displays - Application of new reduction options (file name) is complete.</p> <p>Click OK to close the message box.</p>
<i>Close button Save button</i>	Refer to Common Fields and Buttons - File Menu Options , page 3-1 .

Analysis Options

The **Analysis Options** tab provides details for setting up the sample analysis conditions file. Analysis options can be edited as long as the analysis is not in progress and the sample file does not contain manually entered data. Changes made to analysis parameters are noted in the report header upon completion of the analysis.

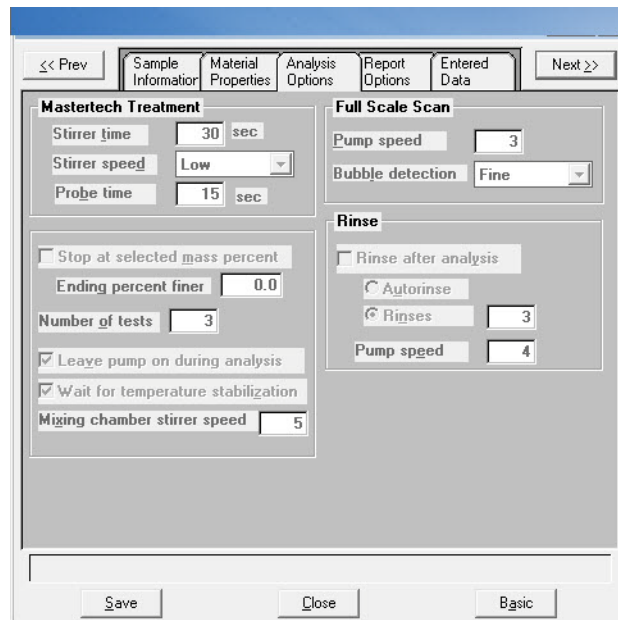

Field or Button	Description
<p>MasterTech Treatment group box (applicable only if using a MasterTech)</p>	<p>Samples tend to settle in the beakers while waiting for sample analysis, especially if samples are prepared ahead of time, as in most cases when using a MasterTech. Program the MasterTech stirrer and probe to re-disperse the sample using options in the group box.</p> <ul style="list-style-type: none"> • Stirrer time - the number of seconds to have the stirrer operate during resuspension. • Stirrer speed - coarse materials and less-stable dispersions may require more high-speed stirring than finer materials. Range: 1 to 10, with 1 being the slowest • Probe time - how long to have the ultrasonic probe operate during resuspension. Coarse materials and less-stable dispersions may require more high-speed stirring than finer materials.

Field or Button	Description <i>(continued)</i>
<i>Full Scale Scan group box</i>	<ul style="list-style-type: none"> • Pump speed - the speed at which the cell pump should operate during the full-scale scan. Use a pump speed of 2 or 3 if analyzing fine samples since they pump through the tubing easily. If analyzing coarse particles, especially if dispersed in higher viscosity liquids, a higher pump speed of 4 to 5 should be used. If the analyzer has the smaller 5 mm (3/16 in.) OD tubing, higher speeds may be required for finer particles. • Bubble detection - types of bubble detection. The presence of most bubbles in the cell can be detected during the full-scale scan that takes place at the start of the analysis. Detecting bubbles, however, is somewhat sample-dependent. Samples which contain very large particles may appear to have bubbles near the top of the cell, when actually the sudden change in X-ray intensity is due to incomplete filling of the topmost portion of the analysis cell. For samples of this type, select Coarse bubble detection. If only small particles are present in the sample (less than 1 mm), select Fine bubble detection. For samples between these two ranges, select Medium bubble detection.

Field or Button	Description <i>(continued)</i>
<i>Other items group box</i>	<ul style="list-style-type: none"> • Stop at selected mass percent - stops analysis at a specified mass percent finer. If unsure of the smallest size particle present in the sample, it may be difficult to determine an ending diameter which will include the selected data. With this option, choose to end mass percent at 0%, after having set the ending diameter at a small value of approximately 0.1 μm. Using this method, wait time is lessened at the end of the analysis. • Ending percent finer - enabled only if Stop at selected mass percent is selected. Enter the point at which the analysis should stop. • Number of tests - enter the number of analyses to be performed. • Leave pump on during analysis - coarse materials tend to settle in the tubing during analysis. This option allows the pump to operate during analysis, enabling easier rinsing and resuspension of the sample. • Wait for temperature stabilization - select to have the temperature in the analysis compartment and mixing chamber stabilize to within ± 0.5 $^{\circ}\text{C}$ of the setpoint before the analysis begins. • Mixing chamber stirrer speed - adjusts the speed of the magnetic stirring bar, which stirs the mixture in the mixing chamber. Select a number between 1 and 10. 1 represents the lowest speed and 10 the highest.
<i>Rinse group box</i>	<ul style="list-style-type: none"> • Rinse after analysis - select if a rinse cycle should be performed after analysis. • Autorinse - performs up to three cycles of three rinses each (a total of nine rinses) in an attempt to reestablish baseline conditions. If conditions are not reestablished after nine rinses, an error message is displayed. • Rinses - the number of rinses to be performed. • Pump speed - the speed for the cell pump to operate during rinsing. The range is 1 to 5, with 1 being the slowest.
<i>Close button</i> <i>Save button</i> <i>Basic button</i>	Refer to Common Fields and Buttons - File Menu Options , page 3-1.

Liquid Properties

Liquid Properties is used to edit the properties of an analysis liquid and to specify properties for a new liquid properties file.

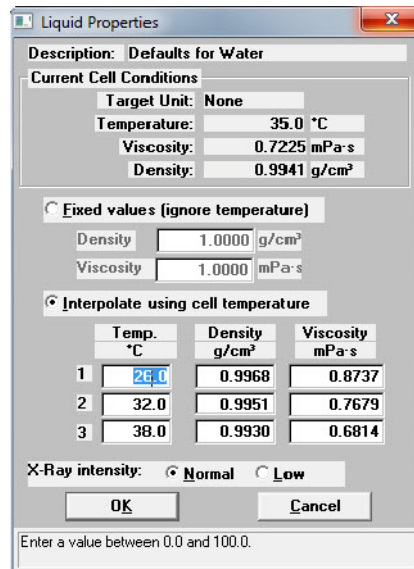

Liquid Properties

Description: Defaults for Water

Current Cell Conditions

Target Unit: None

Temperature: 35.0 °C

Viscosity: 0.7225 mPa·s

Density: 0.9941 g/cm³

Fixed values (ignore temperature)

Density: 1.0000 g/cm³

Viscosity: 1.0000 mPa·s

Interpolate using cell temperature

	Temp. °C	Density g/cm ³	Viscosity mPa·s
1	25.0	0.9968	0.8737
2	32.0	0.9951	0.7679
3	38.0	0.9930	0.6814

X-Ray intensity: Normal Low

OK Cancel

Enter a value between 0.0 and 100.0.



The liquid properties is edited by selecting the Materials Properties window and clicking the Properties button in the Analysis Liquid group box.

Field or Button	Description
<i>Description</i>	If editing an existing file, this field contains the name of the selected file. If defining a new file, enter a name in this field.
<i>Current Cell Conditions group box</i>	<p>Displays the cell conditions of the analysis unit. These conditions are based on the temperature of the cell and are used in computing the analysis statistics displayed on the Material Properties window.</p> <p>Choose either fixed values or interpolated values based on the cell temperature.</p> <ul style="list-style-type: none"> Fixed values - enter a value in the Viscosity and Density fields. These values will be maintained regardless of the cell temperature.

Field or Button	Description (<i>continued</i>)
<i>Current Cell Conditions group box (continued)</i>	<ul style="list-style-type: none"> • Interpolate using cell temperature - enter three sets of values in the Temp., Density, and Viscosity fields. These values will be used to interpolate the density and viscosity at the current cell temperature. <p>The table requires that the entered values be properly ordered. Temperature in ascending order for example. Enter values from left-to-right and from top-to-bottom.</p>
<i>X-Ray intensity</i>	<ul style="list-style-type: none"> • Normal - optimized for most applications when using high X-ray absorption liquids, such as water. • Low - decreases intensity when using low X-ray absorption liquids, such as hydrocarbons.
<i>Cancel button</i> <i>OK button</i>	Refer to Common Fields and Buttons - File Menu Options , page 3-1 .

Report Options Files

File > Open > [.RPO file] (or click the **Report Options** tab when in Advanced format)

Use to specify report options for collected (from an analysis) or manually entered data. Report Options files also help in customizing report details such as axis scale, axis range, column headings, and components of thickness curve equations. Refer to **REPORTS MENU**, page 5-1.

Customized report options files can be created then loaded into a sample file allowing quick and easy generation of reports.

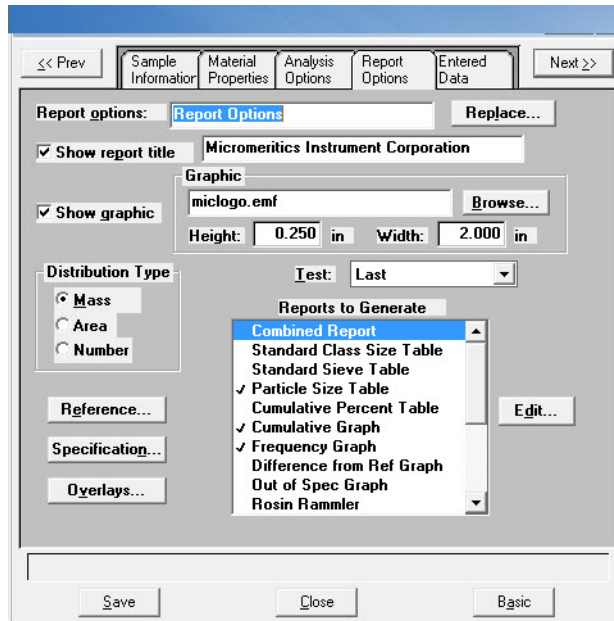

Field or Buttons	Description
<i>Report options</i>	When editing an existing file, this field displays the identification of the report options file.
<i>Show report title</i>	Select to include a title in reports. Enter the title name in the text box. Refer to Report Header , page 5-16.
<i>Show graphic</i>	Select to include a graphic. Enter the pathname of the graphic or click Browse and select a file. Refer to Report Header , page 5-16. Height / Width - Enter the height and width of the graphic, in inches.
<i>Distribution Type</i>	Select the type of distribution data to report.

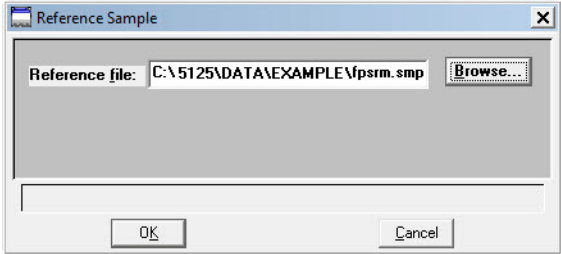
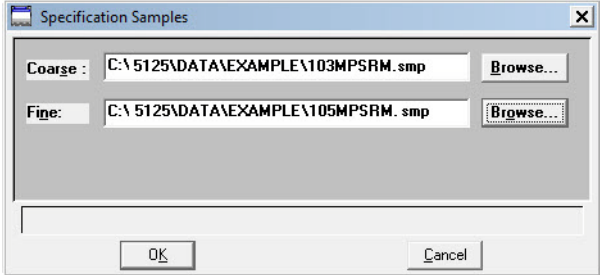
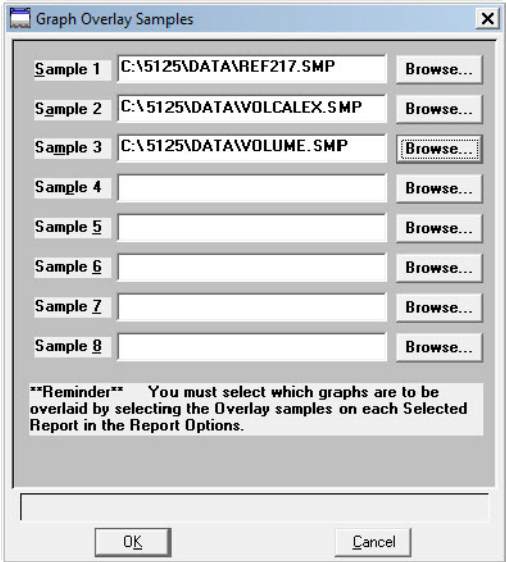
Field or Buttons	Description (<i>continued</i>)
<i>Reference button</i>	<p>Specify a reference sample file to compare analysis results of the current sample.</p> 
<i>Specification button</i>	<p>Select the sample files to be used for the coarse and fine specification boundaries to determine if the results of the current sample are within the specified boundaries.</p> 
<i>Overlays button</i>	<p>Select the sample files to overlay onto selected plots.</p> 
<i>Test dropdown list</i>	<p>Select the analysis for the report</p>

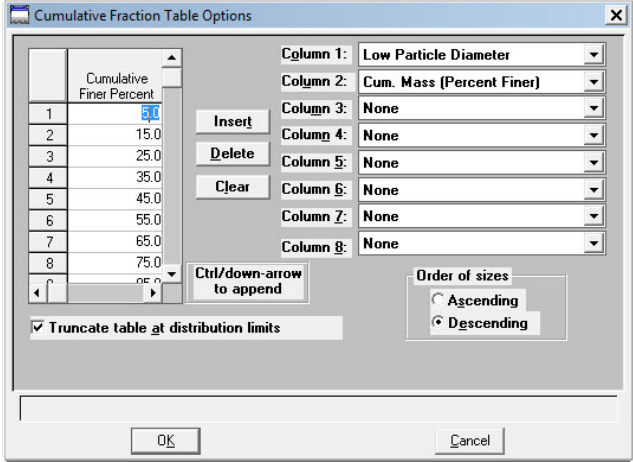
Field or Buttons	Description (<i>continued</i>)
Reports to Generate	Contains a list of available reports.
Edit button (for tables)	<p>Click to edit the options of the table reports in the Reports to Generate list box. Highlight the report then click Edit. Views will vary depending on the report selected.</p>  <ul style="list-style-type: none"> • Column [n] - specify the type of data to display in that column. • Order of Sizes - choose the order for data. • Truncate table at distribution limits - use to shorten the table to the limits of the distribution. • Data Points Table - enter the values for the reported data.

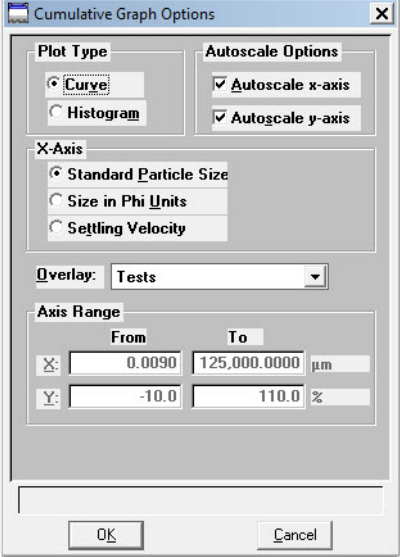
Field or Buttons	Description (<i>continued</i>)
<p><i>Edit button (for graphs)</i></p>	<p>Use to edit a graph in the Reports to Generate box. Highlight the graph and click Edit.</p>  <ul style="list-style-type: none"> • Plot Type - select either curve or histogram for the plotted graphs. • Autoscale Options - automatically scales the X- and / or Y-axes automatically. Both axes begin at zero, and the system uses the highest values collected during analysis as the ending points. The Axis Range fields are disabled if autoscale data is selected. • X-Axis - select how to display the X-axis values. • Overlay - displays the types of overlays <ul style="list-style-type: none"> – Samples - select to to overlay the same type of curve from a different data reduction. Then click Overlays on the Report Options window. – Tests - use to overlay the same type of curve from all tests performed with this file. • Axis Range - specify beginning and ending values for the X- and Y-axis ranges. Data collected outside these ranges are not included in the plot.

Field or Buttons	Description (<i>continued</i>)
<p><i>Browse button</i></p> <p><i>Cancel button</i></p> <p><i>Close button</i></p> <p><i>OK button</i></p> <p><i>Save button</i></p> <p><i>Table buttons</i></p>	Refer to Common Fields and Buttons - File Menu Options , page 3-1.



The values entered in the To fields must be greater than the values entered in the From fields.

Collected / Entered Data

This window displays only when using the Advanced presentation format. Depending on the type of data selected on the **Sample Information** window, this window displays as either **Collected Data** or **Entered Data**.

Collected Data

The screenshot shows the 'Collected Data' window with the following data table:

	Particle Diameter (µm)	Cumulative Finer Percent
1	0.1830	1.46
2	0.1939	1.12
3	0.2054	0.86
4	0.2175	0.66
5	0.2304	0.51
6	0.2441	0.42
7	0.2585	0.35
8	0.2738	0.30
9	0.2901	0.25
10	0.3073	0.19
11	0.3255	0.11
12	0.3447	0.02
13	0.3652	0.06

Control options visible in the window include:

- Test: Last
- Delete test
- Merge with external data
- External Data...
- Full scale mass percent: 100.0
- Distribution Type:
 - Mass
 - Area
 - Number

Field or Button	Description
<i>Table</i>	Displays the data collected for the current test.

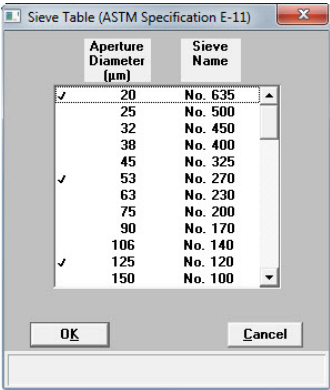
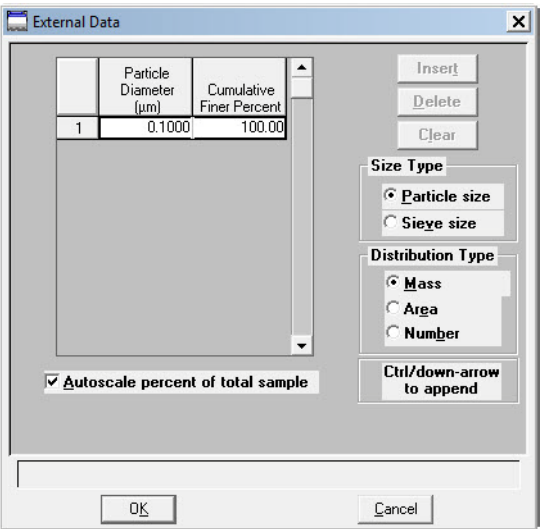
Field or Button	Description (<i>continued</i>)
<i>Test dropdown list</i>	Displays the current test for this sample file. To view data for another test, click on the down arrow to select the test.
<i>Delete test button</i>	Deletes the selected test.
<i>Merge with external data checkbox</i>	Select to merge data collected by manual methods with the collected data.
<p>External Data button</p>  <p>This table displays if Sieve Size is selected for the size type.</p>	<p>Enabled when Merge with external data is selected. Displays the External Data window for the entry of data to be merged.</p>  <ul style="list-style-type: none"> • Insert button - insert new data in the table. If this is a particle size table, enter the particle size and cumulative percent for the particle. If this is a sieve table, a set of sieves is displayed to enter the percent passed through each size. • Delete button - removes the selected row from the table. • Clear button - deletes all but one entry of the table (one entry is required). • Size Type - specify the type of size data. <ul style="list-style-type: none"> – Particle size - particle diameter and cumulative percent for the sample. – Sieve size - the percent passed through each sieve.

Field or Button	Description (<i>continued</i>)
<p>External Data button (<i>continued</i>)</p>	<ul style="list-style-type: none"> • Distribution Type - specify the type of distribution data. • Autoscale percent of total sample - when selected, the overlapping regions of the collected data and the merged data are used to rescale the collected data so that the regions match. <p>When deselected, the percentages entered for the merged data are used and the non-overlapping portion of the collected data is scaled to be the percent passing through the smallest sieve.</p>
<p>Full scale mass percent text box</p>	<p>Specify the weight percent of the sample actually analyzed by the analyzer versus the percent that is manually analyzed. The data are scaled accordingly.</p> <p>Select if part of the sample was analyzed by another method but you do not want to merge those results with the reports for the current analysis.</p> <p>This field is disabled if Merge with external data is selected.</p>
<p>Distribution Type</p>	<p><u>Option disabled.</u> Select the Distribution Type from the Report Options window.</p>
<p>Cancel button Close button OK button Save button</p>	<p>Refer to Common Fields and Buttons - File Menu Options, page 3-1.</p>

Entered Data



Data cannot be entered if the analysis program is being used for offline data manipulation on a computer other than the one controlling the analyzer.

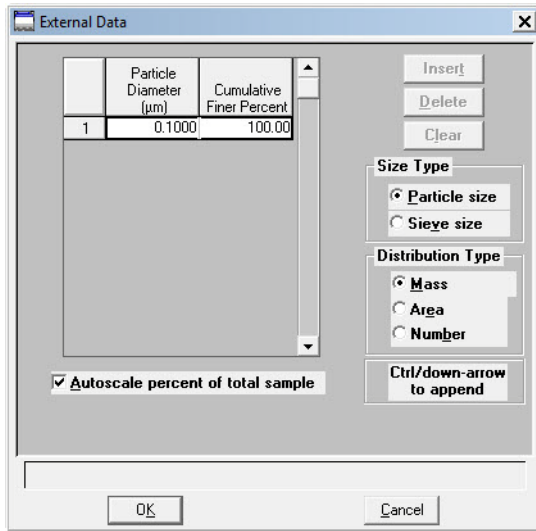

Field or Button	Description
<i>Insert button</i>	Enter new data in the table. If this is a particle size table, enter the particle size and cumulative percent for the particle. If this is a sieve table, a set of sieves is displayed for the entry of percent passed through each size.
<i>Size Type</i>	<p>Size Type - specify the type of size data.</p> <ul style="list-style-type: none"> • Particle size - particle diameter and cumulative percent for the sample. • Sieve size - the percent passed through each sieve.
<i>Distribution Type</i>	Specify the type of distribution data.
<i>Cancel button</i> <i>Close button</i> <i>OK button</i> <i>Save button</i> <i>Table buttons</i>	Refer to Common Fields and Buttons - File Menu Options , page 3-1.

4. UNIT MENU

Introduction

This chapter contains information specific to the Unit menu options. These options are used to run analyses on one or more units attached to a controlling computer. This chapter provides details of Unit menu options, and descriptions of commonly used functions and buttons.

The title bar of the main window displays as *Unit [n]* for each attached unit. Each unit has a status window displayed in different colors.



The Unit menu does not appear on the menu bar if the analysis program is being used for offline data manipulation.



Common field and button descriptions are listed in a Common table at the beginning of their respective chapters. Field and button descriptions not listed in the Common table are listed in their appropriate heading.

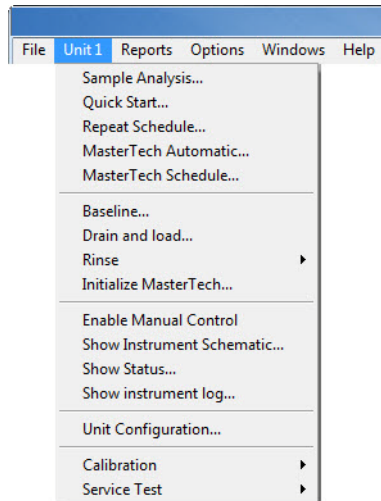

Common Fields and Buttons - Unit Menu Options

The following fields and buttons are common to many of the Unit menu options. References are made to these fields and buttons throughout this manual.

Field or Button	Description
<i>Browse button</i>	Click to search for a file. Select a file and click OK or double click the file name.
<i>Cancel button</i>	Discards any changes made to the screen or cancels the current process. On the Analysis window, at the prompt, choose the port(s) to cancel.
<i>Clear button</i>	Removes all of the entries at once.
<i>Close button</i>	Click to close the active window.
<i>Delete button</i>	Deletes unwanted files.
<i>Edit button</i>	On the analysis window, click to edit the sample information file. Refer to Sample Information Files - Advanced Format , page 3-6.
<i>Next >></i>	Click to move to the next screen.
<i>OK button</i>	Click to save and close the active window.
<i><< Prev</i>	Click to move to the previous screen.
<i>Replace button</i>	Copies values from an existing file into the active file. On the pop-up window, choose the file containing the values to be copied. Click OK , the values are copied into the new file.
<i>Report Options</i>	<ul style="list-style-type: none"> • Report After Analysis - designate report options to be generated after each analysis. • Number of Reports - specify the number of reports to print if Printer or Printer / Plotter is selected for the destination. • Destination- select the print output destination. • File name - enabled only if File is the destination. Enter a file name. <p>If File is selected, the tabular reports of the requested file are converted to a text file which can be viewed with a text editor or other text file manipulation tools.</p>
<i>Start button</i>	Click to start an operation.

Field or Button	Description (<i>continued</i>)
<i>Table buttons</i>	<ul style="list-style-type: none"> • Insert - inserts one row above the selected row. • Delete - deletes the selected row. • Clear - clears all table entries and displays only one default value. • Append - inserts one row at the end of the table.
<i>View dropdown list</i>	<ul style="list-style-type: none"> • Operation - use to display the current mode of operation. • Analysis Log - use to display recent analyses, calibrations, errors or messages. Refer to Show Instrument Log, page 4-30. • Analysis Results - displays the results of the current analysis. • Instrument Schematic - use to display a schematic of the analyzer system. Refer to Show Instrument Schematic, page 4-28.

Sample Analysis

Unit [n] > Sample Analysis

Use to perform individual sample analyses.

The screenshot shows the 'Sample Analysis' dialog box. At the top, there is a 'View:' dropdown menu set to 'Operation' and a 'Browse' button. Below this is a 'Sample:' text field containing '000-006'. The 'Analysis Conditions' section includes a dropdown for 'Garnet Medium Particle Size Reference', 'Sample:' set to 'Garnet', 'Liquid:' set to 'Water', 'Sample Density' set to '3.880 g/cm³', and 'Number of tests' set to '2'. There is a checked checkbox for 'Rinse after analysis'. The 'Report Options' section also has a dropdown for 'Garnet Medium Particle Size Reference' and a list of report types: 'Combined Report' (checked), 'Standard Class Size Table', 'Standard Sieve Table', 'Particle Size Table', 'Cumulative Percent Table', and 'Cumulative Graph' (checked). There is a 'Merge with external data' checkbox and an 'External Data...' button. A 'Full scale mass percent' field is set to '100.0' with a 'Replace...' button. At the bottom, there are navigation buttons: '<< Prev', 'Next >>', 'Cancel', and 'Close'. A status bar at the very bottom displays: 'SediGraph: C:\...\EXAMPLE\000-006.SMP', 'Time Remaining: 1:23 hrs:min', 'Cell Temp.: 34.9 °C', and 'X-Ray Counts: 140 kCnts/s'.

Field or Button	Description
<i>Sample</i>	Displays the sample identification.

Field or Button	Description (<i>continued</i>)
<i>Analysis Conditions</i>	Displays the analysis conditions file in the selected sample information file. Click the dropdown arrow to select another analysis condition file. This list is disabled for files used for an analysis.
<i>Sample / Liquid</i>	Displays the type of sample and dispersing liquid used with the analysis conditions file.
<i>Sample Density</i>	Displays the density of the sample specified in the analysis conditions file. Properties may be edited if the sample file is not complete (used in an analysis). If significant adjustments are required, switch to advanced mode and define a new type of sample material.
<i>Number of tests</i>	Enter the number of analyses to perform using this sample file.
<i>Rinse after analysis</i>	Rinses the cell, tubing, and mixing chamber after each analysis. It is highly recommended that this option remain selected. If this option is deselected and rinses are not performed after analysis, inaccurate results may be obtained.
<i>Report Options</i>	Displays the report options file in the selected sample information file.
<i>Reports list box</i>	Displays the selected reports from the file selected in the Report Options dropdown list.
<i>Merge with external data</i>	Select to merge data collected using manual methods with the data collected for the current analysis.
<i>External Data button</i>	Refer to External Button in the Field or Button table in Collected / Entered Data , page 3-27.
<i>Full scale mass percent</i>	Refer to External Button in the Field or Button table in Collected / Entered Data , page 3-27.
<i>Next >></i>	Saves all selections and displays options for Drain and Load and Report options .
<i>Drain and load options</i>	<ul style="list-style-type: none"> • Prepare SediGraph to load sample - select if the sample has not been loaded into the mixing chamber. If selected, a drain and load operation is performed. • Leave liquid in mixing chamber / Leave mixing chamber empty - select if the liquid should remain in the mixing chamber or leave the mixing chamber empty.
<i>Report</i>	Displays the report(s) selected in the report options file.

Field or Button	Description (<i>continued</i>)
<i>Browse button</i> <i>Cancel button</i> <i>Close button</i> <i>Next >> button</i> <i>OK button</i> <i><< Prev button</i> <i>Replace button</i> <i>Report Options</i> <i>Start button</i> <i>Table buttons</i> <i>View dropdown list</i>	Refer to Common Fields and Buttons - Unit Menu Options , page 4-2.

Quick Start

Unit [n] > QuickStart

Use this mode of operation to analyze a series of samples of the same type which contain the same analysis conditions. Sample files are created automatically.

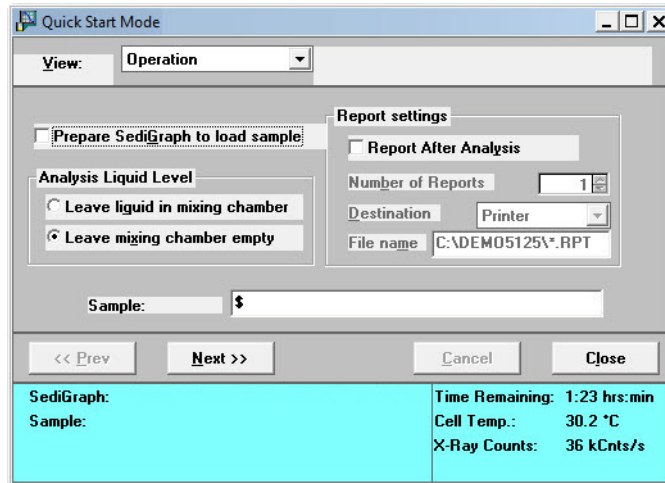

Field or Button	Description
<i>Prepare SediGraph to load sample</i>	Select if the sample is not loaded. If selected, an initial drain and load operation is performed.
<i>Analysis Liquid Level</i>	Specify to leave analysis liquid in the mixing chamber or leave the mixing chamber empty between samples.
<i>Sample</i>	Use to automatically generate sample files with a different string other than the one specified in sample defaults. Include the \$ symbol to have the sample number included as part of the name.
A prompt displays indicating to load the sample when Next >> is clicked.	
If Prepare SediGraph to load sample is selected, a drain operation is performed before the following window is displayed.	

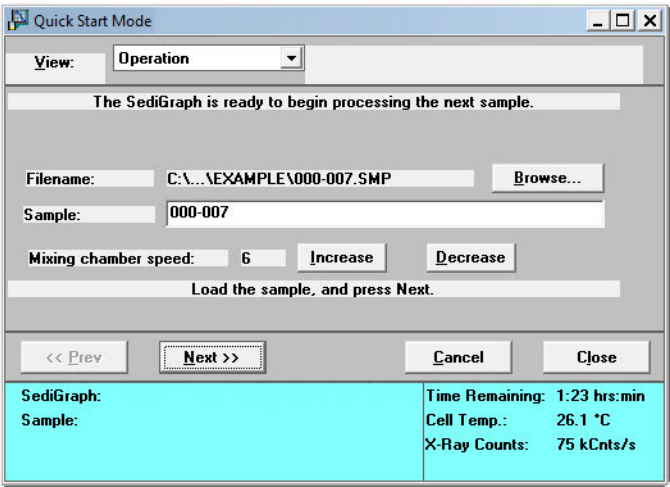

Field or Button	Description (<i>continued</i>)
	
Filename	Defaults to the next sequenced sample number for the next analysis.
Sample	Enter a name for the sample.
Mixing chamber speed	Specify the mixing chamber stirrer speed using the Increase and Decrease buttons.

Click **Next >>** to display the analysis in progress. A baseline graph and full-scale scan are displayed in the left side of the window, while sample data (as they are collected) are displayed in the right side of the window.

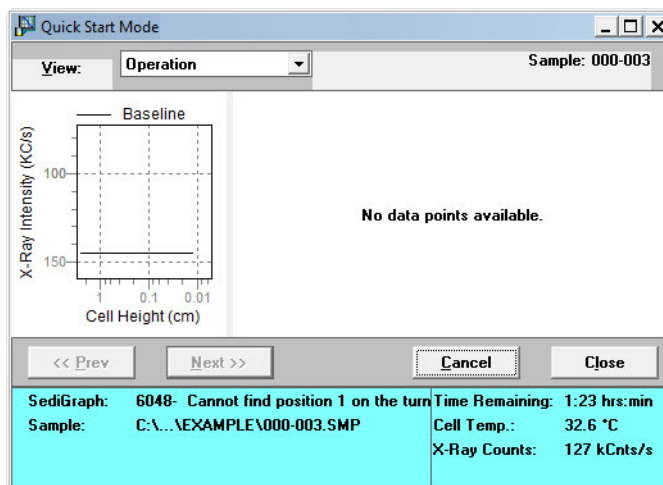

When the analysis is finished, the start next analysis view is displayed.

Field or Button	Description (<i>continued</i>)
<p><i>Browse button</i> <i>Cancel button</i> <i>Close button</i> <i>Next >> button</i> <i>OK button</i> <i><< Prev button</i> <i>Report Settings</i> <i>View dropdown list</i></p>	<p>Refer to Common Fields and Buttons - Unit Menu Options, page 4-2.</p>

Repeat Schedule

Unit [n] > Repeat Schedule

Use to perform multiple analyses on the same sample. View the analyses in progress by selecting *Analysis Results* in the **View** dropdown list.

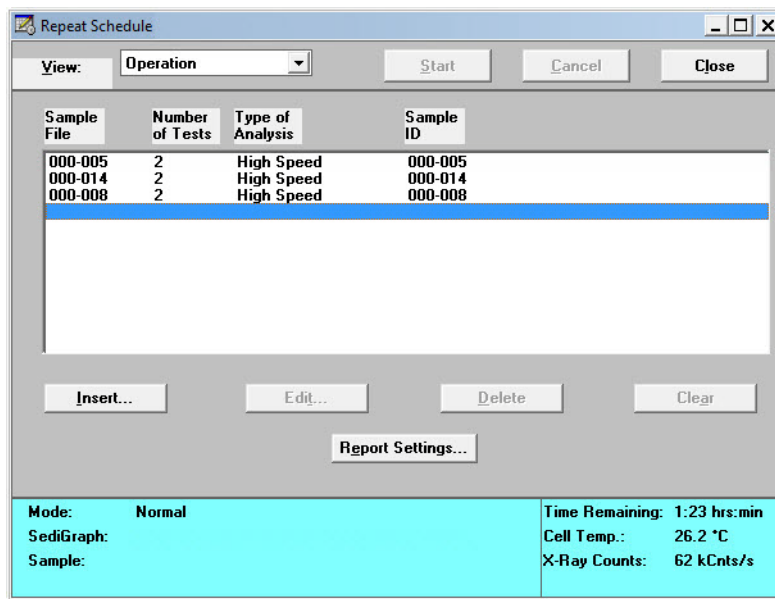

Fields or Buttons	Description
<p><i>Repeat Schedule window</i></p>	<p>Displays the sample files selected for analysis.</p>

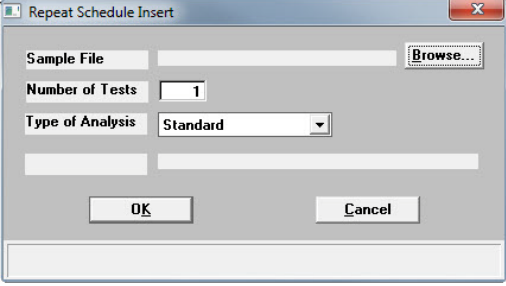
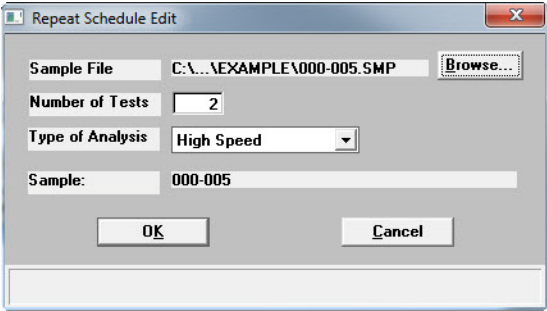
Fields or Buttons	Description (<i>continued</i>)
<i>Insert button</i>	<p>Use to select the sample files for the analyses.</p>  <ul style="list-style-type: none"> • Number of Tests - enter the number of analyses to perform using the selected sample information file. • Type of Analysis - select either Standard, High Speed or High Resolution.
<i>Edit button</i>	<p>Click to edit the selected file.</p> 
<p><i>Browse button</i> <i>Cancel button</i> <i>Clear button</i> <i>Delete button</i> <i>OK button</i> <i>Report Settings button</i> <i>Start button</i> <i>View dropdown list</i></p>	<p>Refer to Common Fields and Buttons - Unit Menu Options, page 4-2.</p>

MasterTech Automatic

Unit [n] > MasterTech Automatic



This option is functional only if a MasterTech is connected to the analyzer.

Use to analyze a series of samples of the same type which contain the same analysis conditions. Sample files are created automatically.

Field or Button	Description
<i>Start with beaker</i>	Enter the position number of the beaker containing the first sample to be analyzed. This field is disabled if an analysis is in progress.
<i>Sample resuspension group box</i>	<p>Enter resuspension parameters. All fields in this group box are disabled if an analysis is in progress.</p> <p>Samples tend to settle in the beaker while waiting for analysis, especially if samples are prepared ahead of time, as in most cases when using a MasterTech. Use the options in this group box to program the MasterTech stirrer and probe to re-disperse the sample before analysis.</p> <ul style="list-style-type: none"> • Stirrer time - enter the number of seconds to have the stirrer operate during resuspension.

Field or Button	Description (<i>continued</i>)
<i>Sample resuspension group box (continued)</i>	<ul style="list-style-type: none"> • Stirrer speed - choose stirrer speed. Coarse materials and less-stable dispersions may require more high-speed stirring time than finer materials. • Probe time - enter how long to have the ultrasonic probe operate during resuspension. Coarse materials and less-stable dispersions may require more probe time than finer materials.
<i>Sample</i>	Enter the name and default string to have applied to the sample files of the current series of analyses. The beaker number containing the sample in the sample identification can be used by entering # within the name. For example, <i>Sample in beaker #</i> .
<i>Cancel button</i> <i>Close button</i> <i>Report Options</i> <i>Start button</i> <i>View dropdown list</i>	Refer to Common Fields and Buttons - Unit Menu Options , page 4-2.

MasterTech Schedule

Unit [n] > MasterTech Schedule





This option is functional only if a MasterTech connected to the analyzer.

Use to:

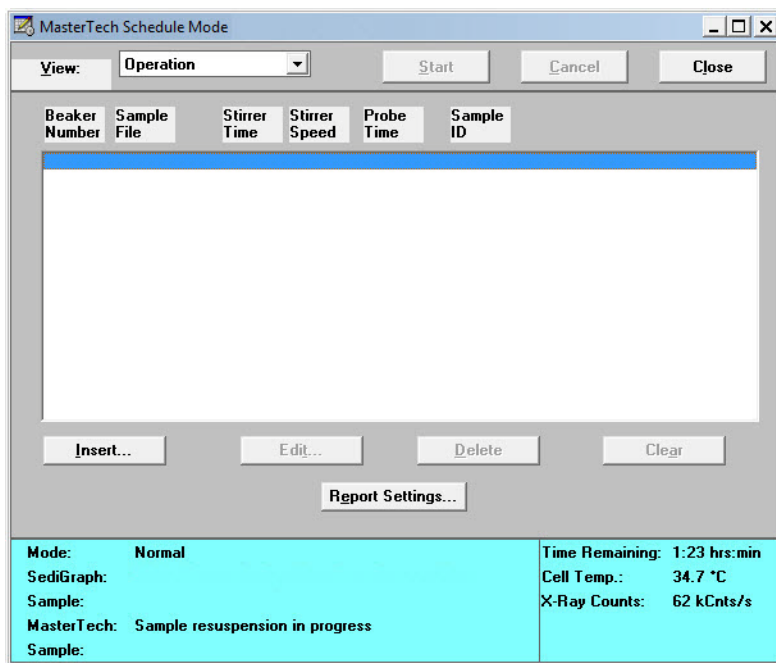
- Analyze a series of samples which may be different in size and shape and require different analysis conditions
- Perform a series of baseline measurements
- Analyze samples and measure a baseline alternately

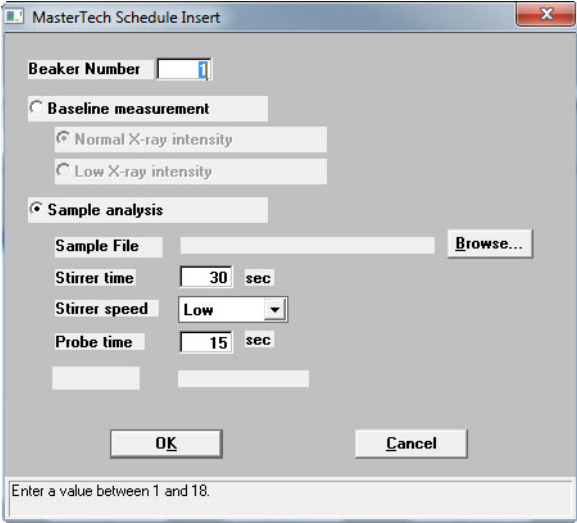

Field or Button	Description
<i>Insert button</i>	<p>Click to insert sample files to be used for analyses.</p>  <p>If a sample file is selected, the new file will be inserted before the selected file; otherwise it will be inserted at the end of the list.</p> <ul style="list-style-type: none"> • Beaker Number - enter the beaker number containing the selected sample (or baseline liquid). • Baseline / Sample analysis - specify either a baseline measurement or sample analysis for the specified beaker. If Baseline measurement is selected, select the X-Ray intensity. <ul style="list-style-type: none"> – Normal - increases intensity when using high X-ray absorption liquids, such as water. – Low - decreases intensity when using low X-ray absorption liquids, such as hydrocarbons.
 <p>Use this option if planning to change dispersing agents with one of the samples. A baseline measurement can then be scheduled using the beaker preceding the one containing the different dispersant. For example, if planning to change dispersing liquids in beaker position #4, schedule a baseline measurement in beaker position #3.</p>	

Field or Button	Description (<i>continued</i>)
<i>Insert button (continued)</i>	<ul style="list-style-type: none"> • Sample analysis - click Browse, then choose the sample file to use with the sample in this beaker position. <ul style="list-style-type: none"> – Stirrer time - the number of seconds to have the stirrer operate during resuspension. – Stirrer speed - choose stirrer speed. Coarse materials and less-stable dispersions may require more probe time than finer materials. – Probe time - the length of time to have the ultrasonic probe operate during resuspension. Coarse materials and less-stable dispersions may require more high-speed stirring time than finer materials. • Sample ID - displays the sample identification string of the selected sample file.
<i>Edit button</i>	Edit a sample file or dispersion conditions. Refer to the Insert button description given above. .
<i>Cancel button</i> <i>Clear button</i> <i>Close button</i> <i>Delete button</i> <i>Report Options</i> <i>Report Settings button</i> <i>Start button</i> <i>View dropdown list</i>	Refer to Common Fields and Buttons - Unit Menu Options , page 4-2.

Baseline

Unit [n] > Baseline

Before performing an analysis, a baseline measurement for data collection must be taken. It is not necessary to measure a baseline for each analysis. Micromeritics recommends that a baseline measurement be performed at the change of each shift or if changing dispersing agents. Up to seven measurements may be performed; however, only the last one obtained may be used.

Field or Button	Description
<i>Prepare to load baseline liquid</i>	Select if the baseline liquid is not loaded. <ul style="list-style-type: none"> Leave liquid in mixing chamber / Leave mixing chamber empty - select if the liquid should remain in the mixing chamber or leave the mixing chamber empty.
<i>X-Ray intensity</i>	<ul style="list-style-type: none"> Normal - increases intensity when using high X-ray absorption liquids, such as water. Low - decreases intensity when using low X-ray absorption liquids, such as hydrocarbons.
<p>If <i>Prepare to load background liquid</i> is selected, a drain and load operation is performed before the baseline measurement begins. Load the baseline liquid when prompted. Click Next>> to begin the baseline measurement.</p>	

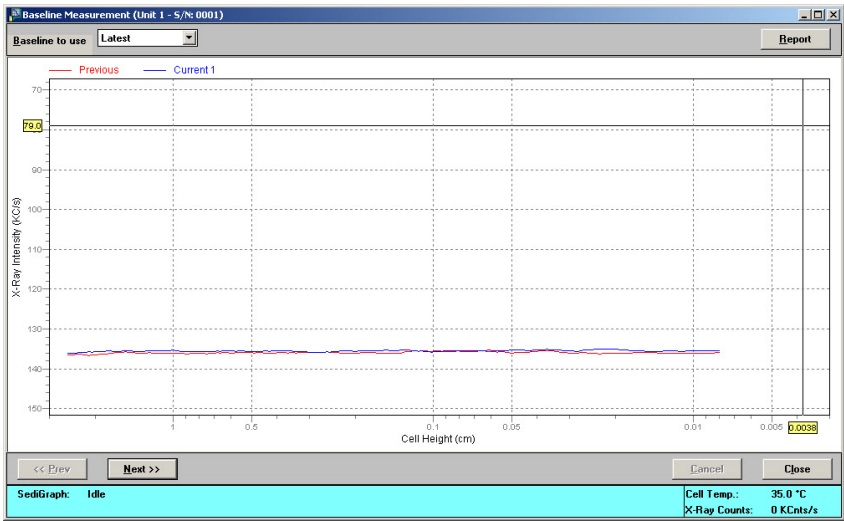
Field or Button	Description (<i>continued</i>)
	
Baseline to use	<p>Select whether to use the latest or the previous baseline.</p> <ul style="list-style-type: none"> • Latest - uses the last baseline performed. • Previous - uses the baseline which was active before the last series of baselines were performed.
<p>Cancel button Close button Next >> button << Prev button Report After Analysis group box</p>	<p>Refer to Common Fields and Buttons - Unit Menu Options, page 4-2.</p>

Drain and Load

Unit [n] > Drain and load

Before collecting baseline data or performing an analysis, the analyzer must be drained of any previous sample (or baseline liquid). Then reload a sample (or baseline liquid). Use one of the following methods:

- Prior to a baseline collection or an analysis, select *Unit [n] > Drain and Load* (explained below).
- At the beginning of a baseline collection, select the **Prepare to load baseline liquid** check box on the **Baseline Measurement** window.
- At the beginning of an analysis, select the **Prepare SediGraph to load sample** check box on the **Select Drain and Load** window..

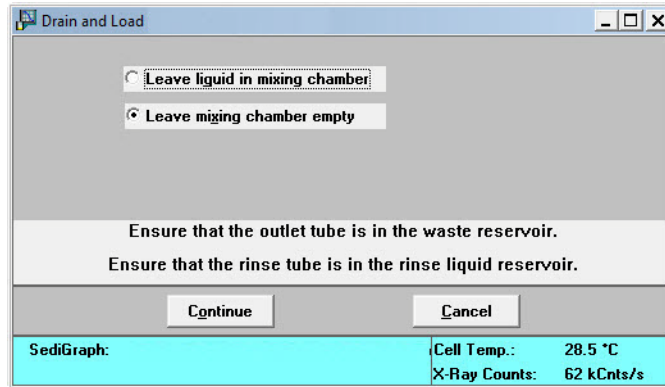

Field or Button	Description
<i>Leave liquid in mixing chamber</i> <i>Leave mixing chamber empty</i>	Select to indicate to leave liquid in the mixing chamber or if leave the mixing chamber empty.
<i>Continue button</i>	Click to continue the drain operation.

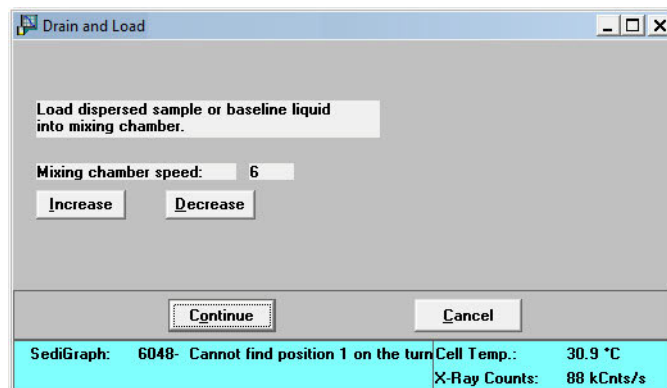

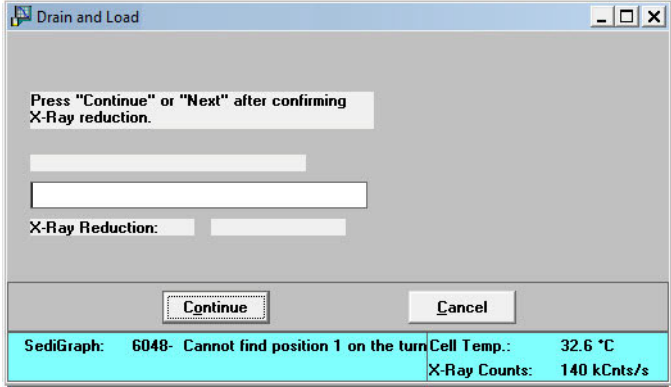
Field or Button	Description (<i>continued</i>)
<i>Mixing chamber speed</i>	Specify the speed of the mixing chamber stirrer using the Increase and Decrease buttons.
<i>Continue button</i>	Select to continue the operation. Refer to the table in Sample Analysis , page 4-3 for more details.
	
<i>Cancel button</i>	Refer to Common Fields and Buttons - Unit Menu Options , page 4-2.

Rinse

Unit [n] > Rinse



A rinse operation cannot be performed when an analysis is in progress.

A rinse operation should be performed to rinse the analysis cell, mixing chamber, and tubing of any contaminants or sample materials from the previous analysis.

When **Rinse** is selected, three choices are available:

- **SediGraph** - rinses the analysis cell, mixing chamber, and the analyzer tubing.
- **MasterTech** - rinses the MasterTech tubing.
- **Both** (SediGraph and MasterTech) - rinses the analysis cell, mixing chamber, the analyzer tubing, and the MasterTech tubing.

SediGraph Rinse

Unit [n] > Rinse > SediGraph

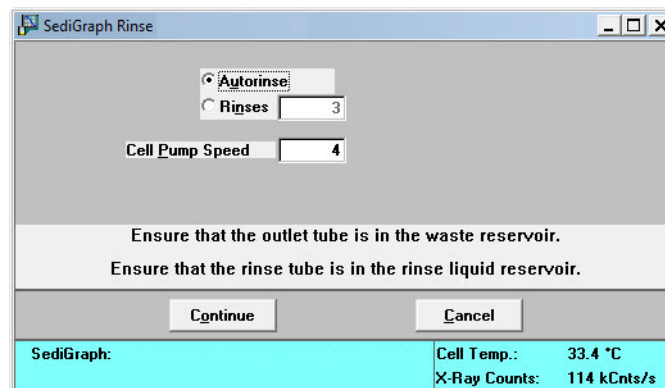

Field or Button	Description
<i>Rinse Cycles</i>	<ul style="list-style-type: none"> • Autorinse - performs up to three cycles of three rinses each (a total of nine rinses) in an attempt to reestablish baseline conditions. If conditions are not reestablished after nine rinses, an error message is displayed. Refer to Autorinse, page 6-4. • Rinses - specifies up to five rinses to be performed.

Field or Button	Description (<i>continued</i>)
<i>Cell Pump Speed</i>	The speed for the cell pump is to operate during rinsing. The range is 1 to 5, with 1 being the slowest.
<i>Continue button</i>	Begins the rinse operation. A message displays indicating a rinse operation is in progress. When rinsing is complete, the window closes.
<i>Cancel button</i>	Refer to Common Fields and Buttons - Unit Menu Options , page 4-2 .

MasterTech Rinse

Unit [n] > Rinse > MasterTech



This option is available only if a MasterTech connected to the analyzer and analyses are not in progress.

Field or Button	Description
<i>Rinse beaker number</i>	Enter the position number of the beaker to rinse into. Ensure the beaker is empty.
<i>Continue button</i>	Begins the rinse operation. A message is displayed indicating a rinse operation is in progress. When rinsing is complete, the window closes.
<i>Cancel button</i>	Refer to Common Fields and Buttons - Unit Menu Options , page 4-2.

Both

Unit [n] > Rinse > Both.

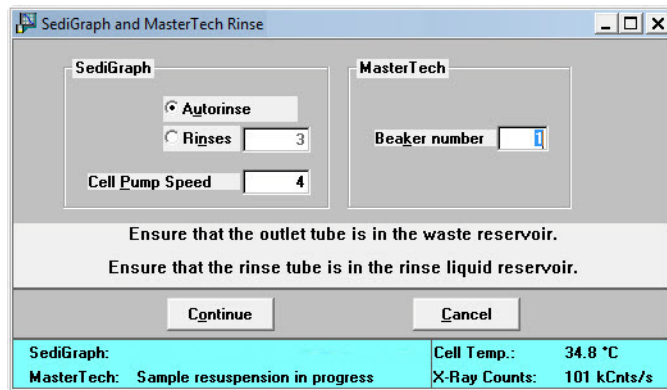

Field or Button	Description
<i>SediGraph</i> group box	<ul style="list-style-type: none"> • Autorinse - the analyzer to automatically determines how many rinse cycles to perform. • Rinses - the number of rinses to perform.
<i>Cell Pump Speed</i>	Enter the speed the cell pump should operate during rinsing. The range is 1 to 5, with 1 being the slowest.
<i>MasterTech</i> group box	Enter the position number of the beaker to rinse into. Ensure that the beaker is empty.
<i>Continue</i> button	Begins the rinse operation. A message is displayed indicating a rinse operation is in progress. When rinsing is complete, the window closes.
<i>Cancel</i> button	Refer to Common Fields and Buttons - Unit Menu Options , page 4-2.

Initialize MasterTech

Unit [n] > Initialize MasterTech

Select this option if:

- Manual operations should be performed with the MasterTech
- The MasterTech beaker tray has been disturbed

When the MasterTech is initialized, the tray is aligned so that beaker #1 is in the starting position..

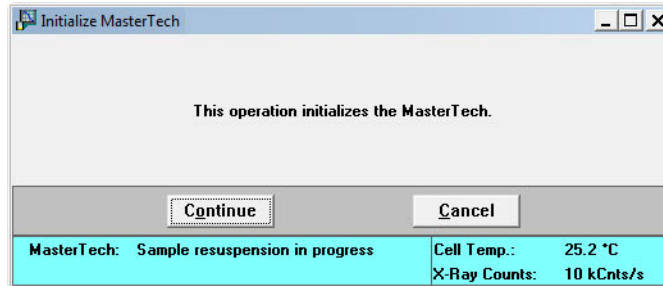

Field or Button	Description
<i>Continue</i> button	Begins the initialization operation. A message is displayed indicating a operation is in progress. When initialization is complete, the window closes.
<i>Cancel</i> button	Refer to Common Fields and Buttons - Unit Menu Options , page 4-2.

Enable Manual Control

Unit [n] > Enable Manual Control

Select this option to manually control the system. If the instrument schematic is not displayed, select *Unit [n] > Show Instrument Schematic*.



Manual Control is disabled if an automatic operation is in progress.

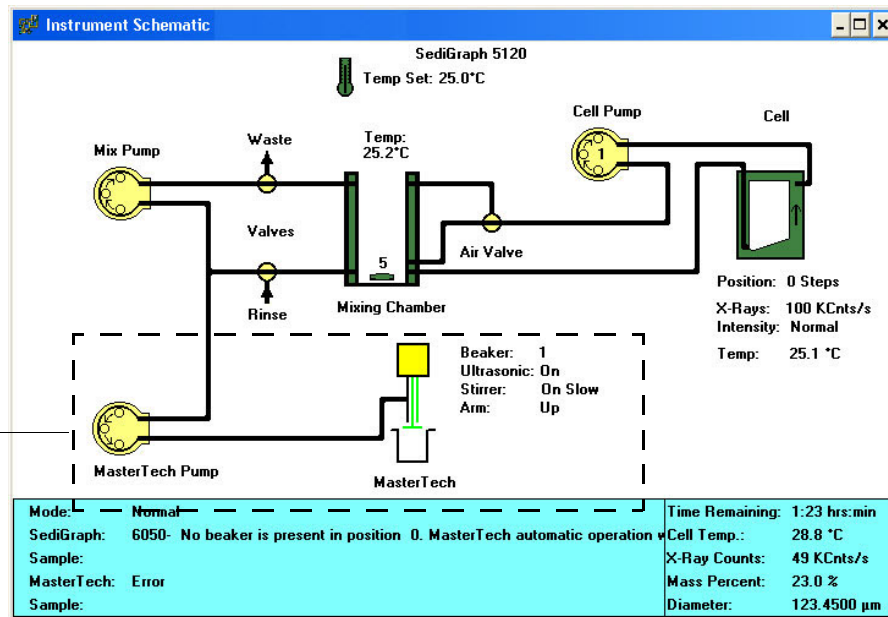

Displayed only if a MasterTech is Installed

When manual control is enabled, the symbols for valves and pumps change color on the control screen to indicate manual operation.

- Valves: Closed = Yellow Open = Green
- Pumps: Off = Yellow On = Green Disabled by front panel switch = Red

Each component has a pop-up menu displaying the operations available for that particular component. These menus may be accessed by right-clicking the component.

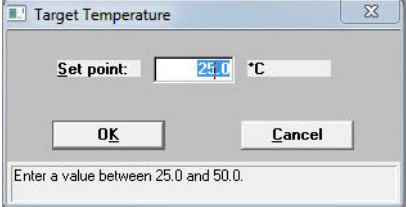
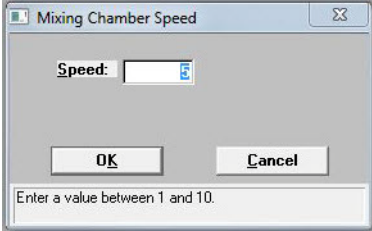
Component	Description
<i>Set Temperature</i>	<ul style="list-style-type: none"> • Set Temperature - set the target temperature.  <ul style="list-style-type: none"> • Set point - enter a temperature set point. Range 25.0 to 50.0°C.
	<p>The set point must be at least 10°C above ambient temperature for accurate control.</p>
<i>Mix Pump</i>	Turns the mixing pump on or off.
<i>Waste Valve</i>	Set the waste valve position.
<i>Rinse Valve</i>	Set the rinse valve position.
<i>Mixing Chamber</i>	<p>The speed of the mixing chamber magnetic stirrer can be set from 1 to 10, with 1 being the lowest speed.</p> <ul style="list-style-type: none"> • Set Speed - displays the Mixing Chamber Speed window.  <ul style="list-style-type: none"> • Speed - controls the stirrer speed by entering a value from 1 to 10. <p>Turns the stirrer on or off.</p>
<i>Air Valve</i>	Sets the position of the air valve.

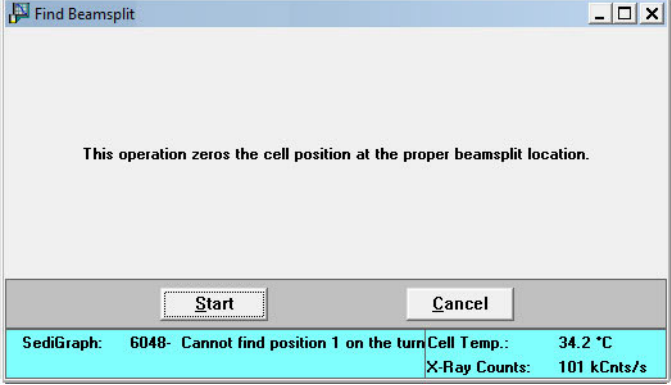

Component	Description <i>(continued)</i>
Cell Pump	<ul style="list-style-type: none"> • Turn Off (or Turn On) - turns the cell pump off or on. • Flow up (or down) in a cell - changes flow direction. Arrows in the pump symbol display the current direction. • Increase (or Decrease) Speed - changes the cell pump speed. The speed of the cell pump can be set from 1 to 5, with 1 being the slowest speed.
Cell	<p>Controls the movement of the analysis cell. An arrow in the cell symbol indicates the direction of cell movement.</p> <ul style="list-style-type: none"> • Move Cell Position - enter the cell position. <div data-bbox="824 764 1170 1056" data-label="Image"> </div> <ul style="list-style-type: none"> – Absolute - move the cell position to an absolute (relative to the last beamsplit location) number of steps. For example, an absolute move of 100 steps moves the cell 100 steps above beamsplit. – Relative - move the cell position to a relative (relative to current position) number of steps. For example, a relative move of 100 steps moves the cell up 100 steps from its current position. – Cell Position - move the cell to the position entered. • Stop Motion - stops cell movement. • X-ray intensity Normal (or Low) - select the X-ray intensity setting.

Component	Description (<i>continued</i>)
<p><i>Cell (continued)</i></p>	<ul style="list-style-type: none"> • Find Beamsplit - zeros the cell position at the proper beamsplit location.  <p>Start - progress messages display.</p> <p>Done - closes the window.</p>
<p><i>MasterTech (shown only if a MasterTech is installed)</i></p>	<ul style="list-style-type: none"> • Move Arm Up (or Down) - MAsterTech arm movement control. • Ultrasonic On (or Off) - turns the ultrasonic probe on or off. • Stirrer On (or Off) - turns the stirrer in the beaker on or off. • Stirrer Speed Fast (or Slow) - stirrer speed control. • Move to next beaker - moves the MasterTech arm to the next beaker position. • Turn On (or Off) - turns the MasterTech pump on and off. • Flow Direction Rinse (or Load) - Sets the flow direction of the MasterTech pump. An arrow in the pump symbol changes to show the current flow direction.

Show Instrument Schematic

Unit [n] > Show Instrument Schematic

Select this option to display a schematic of the analyzer and the MasterTech (if one is being used).

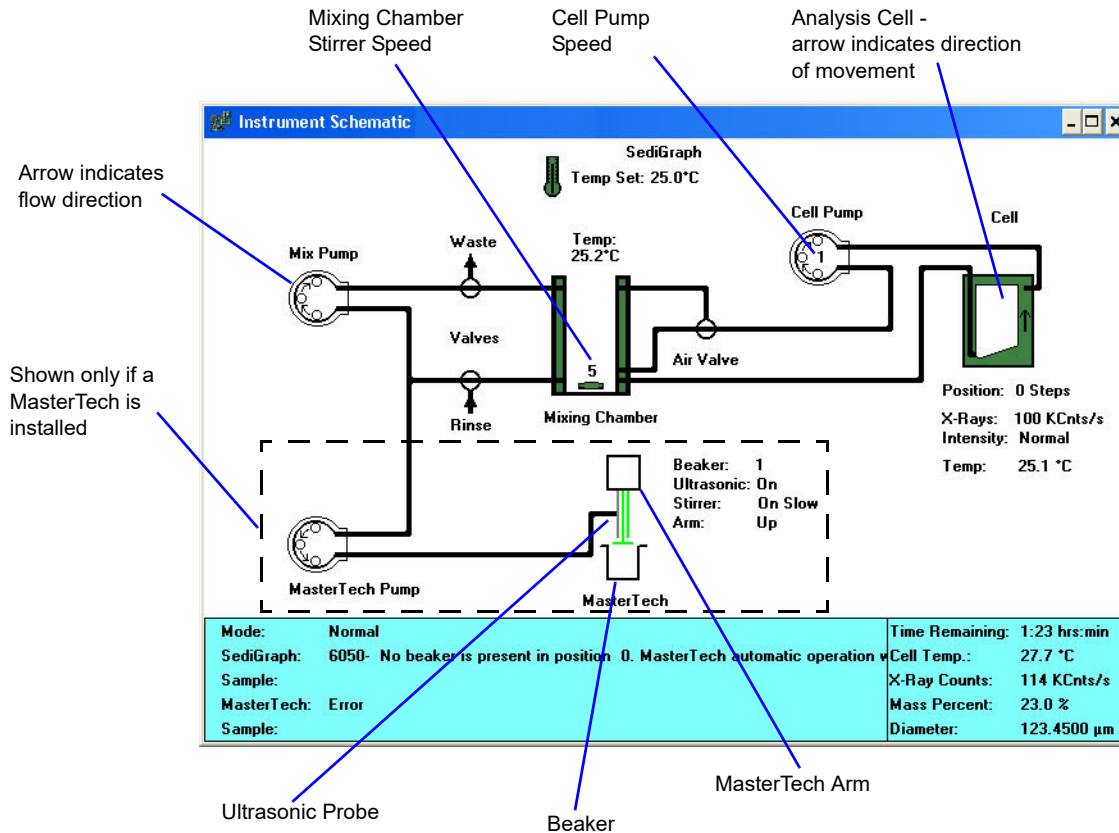

The color of the valves and pumps indicate their state.

- Valves: Closed = White Open = Green
- Pumps: Off = White On = Green Disabled by front panel switch = Red

Show Status

Unit [n] > Show Status

Select this option to show just the status display of an operation in progress; a status window similar to this one is displayed.

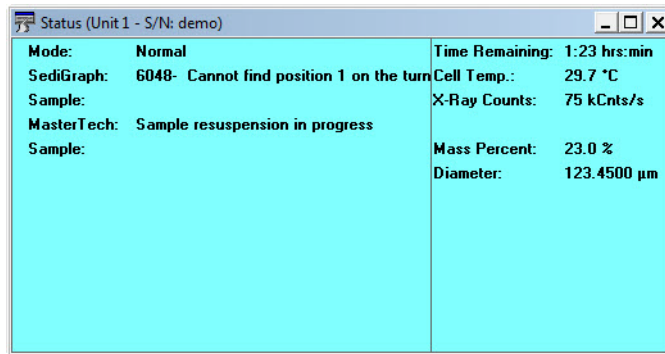

Use this option if:

- There is an automatic operation in progress and a sample file needs to be edited.
- There are two units attached to the computer. Select **Show Status** on each unit menu and have the status for both units displayed simultaneously.

The following items may appear in the status display, depending on the instrument and the operation in progress.

Display	Description
<i>Mode</i>	The type of operation being performed.
<i>SediGraph</i>	The status of the analyzer, such as <i>Analysis operation in progress, Idle, Waiting for load, etc.</i>
<i>Sample</i>	The name of the sample file involved in the operation. This field also displays for the MasterTech if one is being used.
<i>MasterTech</i>	The status of the MasterTech. This field is visible only when a MasterTech is being used.
<i>Time Remaining</i>	The time remaining on the analysis. This field is visible only when an analysis is in progress.
<i>Cell Temp.</i>	The temperature of the liquid in the analysis cell.

Display	Description <i>(continued)</i>
<i>X-Ray Counts</i>	The intensity of the X-ray in kilocounts/sec.
<i>Mass Percent</i>	The current mass percent in the analysis.
<i>Diameter</i>	The current particle size in the analysis.
<i>Analysis Time</i>	The approximate time for the analysis.

Show Instrument Log

Unit [n] > Show instrument log

Displays a log of recent analyses, calibrations, errors or messages. This information is logged for a 7-day period for analyses and a 30-day period for messages and calibrations.

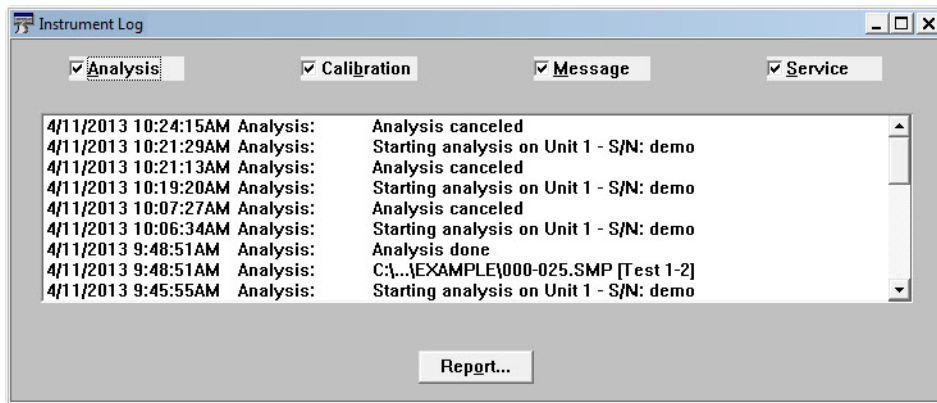

Display	Description
<i>Analysis, Calibration, and Message checkboxes</i>	Select the log contents to display.

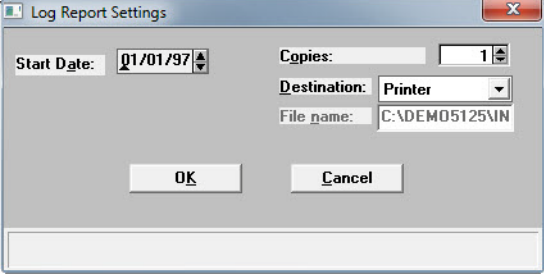
Display	Description <i>(continued)</i>
<i>Report button</i>	<p>Display on the screen or print a report of log entries. The Log Report Settings dialog is displayed.</p>  <ul style="list-style-type: none"> • Start Date - select the start date for log entries to be included in the report. Specify a start date using any of the following methods: <ul style="list-style-type: none"> – Highlight the field (or press F2 to clear the field) and enter a date. – Double-click the field (or press F4) to display a calendar and select a date. – Press F2 to clear the field, then F3 to insert the current date. • Copies - specify the number of reports to print if Printer or Printer/Plotter is selected for the destination. • Destination- select the print output destination. • File name - enabled only if File is the destination. Enter a file name.
<i>Cancel button</i> <i>OK button</i>	Refer to Common Fields and Buttons - Unit Menu Options , page 4-2 .

Unit Configuration

Unit [n] > Unit Configuration

Displays baseline information and software and hardware configuration of the connected analyzer.

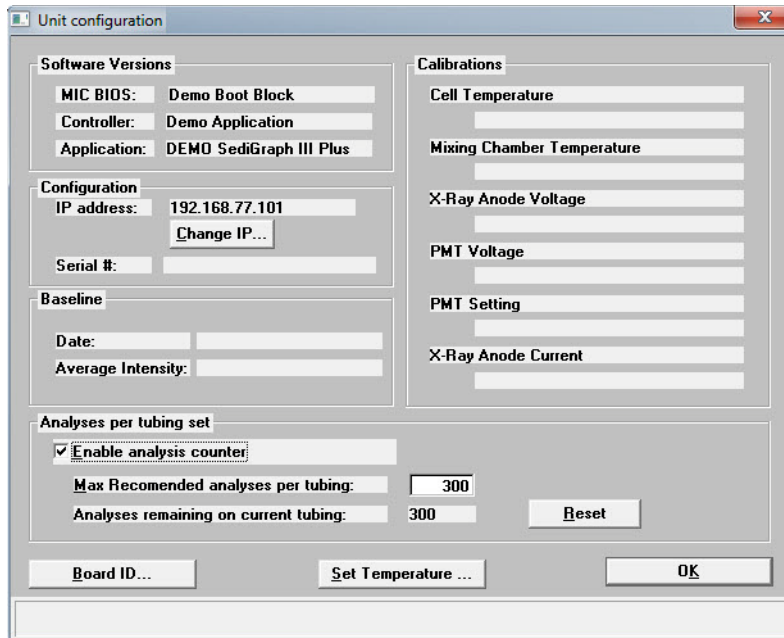

Field or Button	Description
<i>Software Versions group box</i>	Displays the software versions of the MICBIOS and analyzer analysis program.
<i>Configuration group box</i>	Displays the number of the port being used to control the analyzer and the serial number of the selected analyzer.
<i>Baseline group box</i>	Displays the date and the average intensity of the last baseline performed.

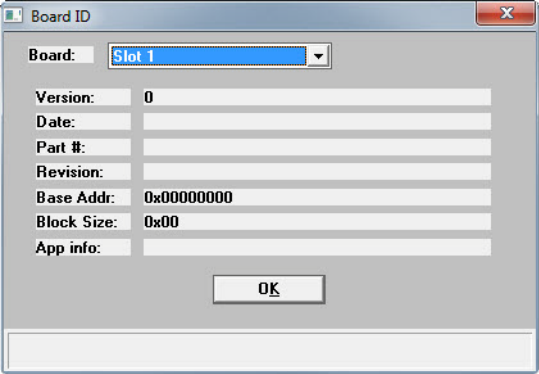
Field or Button	Description <i>(continued)</i>
<i>Analyses per tubing set group box</i>	<ul style="list-style-type: none"> • Enable analyses counter - enables or disables the analyses counter. The analysis program keeps a counter of the number of analyses remaining on the instrument before the next recommended tubing change. For every sample information file for which an analysis is started (does not include service tests or baseline measurements) this counter is decremented. • Max Recommended analyses per tubing set - enter the maximum number of analyses to be performed before the application displays this message: <i>The maximum number of analyses for this tubing has been reached. It is time to change the tubing. When the tubing has been replaced, reset the counter in the unit configuration dialog.</i> • Analyses remaining on current tubing - displays the number of analyses remaining before the maximum recommended number is reached. • Reset button - resets the analyses counter to the recommended maximum number.
<i>Calibrations group box</i>	Displays calibration data.
<i>Board ID button</i>	<p>Displays the Board ID dialog, which describes the circuit boards in the analyzer. Use the Board dropdown list to select a board to view.</p> 

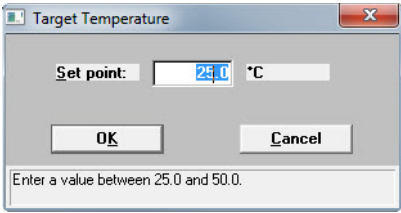
Field or Button	Description (<i>continued</i>)
<i>Set Temperature button</i>	<p>Set the target temperature.</p> 
<i>Reset button</i>	<p>Resets the analysis counter to the recommended maximum number.</p>
<i>Cancel button</i> <i>OK button</i>	<p>Refer to Common Fields and Buttons - Unit Menu Options, page 4-2.</p>

Calibration

Unit [n] > Calibration

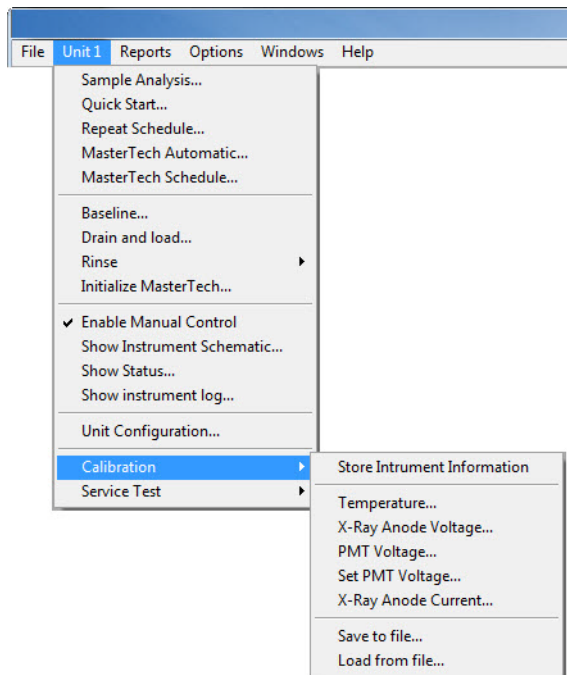

The Calibration option provides a method of storing instrument calibration data. Your Micromeritics service representative may use this option to enter calibration data for future reference when servicing the analyzer. This option is enabled only when the analysis program is operating in Service Test mode. Refer to [Service Test Mode](#), page 6-5.

Service Test

Unit [n] > Service Test

Use for service tests performed only with the assistance of a trained Micromeritics service representative. These tests provide the service representative with troubleshooting tools and readouts.

This option is enabled only when the analysis program is operating in Service Test mode. Refer to [Service Test Mode](#), page 6-5.

5. REPORTS MENU

Introduction

This chapter contains information specific to the Reports menu options used to customize and run reports. This chapter provides details of Reports menu options, commonly used functions and buttons, field-by-field descriptions, and sample reports.

Reports can be generated for data:

- collected on a sample that has completed analysis
- collected on a sample currently being analyzed
- manually entered

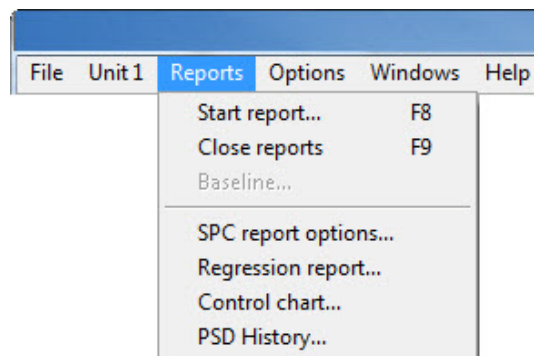

Common Fields and Buttons - Reports Menu Options

The following fields and buttons are common to many of the report files. References are made to these fields and buttons throughout this chapter.

Field or Button	Description
<i>Add button</i>	Select the file and click Add to move a file from the Files list to the Selected Files list or double-click the files to move them. Multiple files can be selected by holding down Ctrl key while making selections.
<i>Browse button</i>	Click to locate another file.
<i>Cancel button</i>	Closes the window and cancels any unsaved changes.
<i>Close button</i>	Closes the active window.
<i>Dates button</i>	Use to filter the files by a date range. Only the files with the selected date range display.

Field or Button	Description <i>(continued)</i>
<i>Delete button</i>	Deletes a selected file from the Selected Files list and move it back to the Files list.
<i>File name text box</i>	Select a file from Files list box. The file name displays in the File name text box. Click Open or double-click the file name to open the file. To select multiple files, hold down the Ctrl key on the keyboard while selecting the files, or hold down the Shift key to select a range of files.
<i>From / To text boxes</i>	Enter the From and To range for autoscaling the x- and / or y-axes.
<i>Name column</i>	Displays a list of files in the selected directory.
<i>Number of Reports</i>	Enter the number of reports copies to generate.
<i>OK button</i>	Click to save and close the active window.
<i>Open button</i>	Select a file from the Files list. Click Open to open the file.
<i>Report button</i>	Click to generate the report.
<i>Save button</i>	Saves the active file.
<i>Settings group box</i>	<ul style="list-style-type: none"> • Copies - select the number of copies to print. • Destination - sends the file to the selected destination. • Filename - enabled when Screen is selected for the destination. The report will be saved under the entered filename.
<i>Show graphic</i>	Select to have a graphic display on the report header. Refer to Report Header , page 5-16 .
<i>Show report title</i>	Select to have a title display on the report header. Enter a title in the text box. Refer to Report Header , page 5-16 .
<i>Status dropdown list</i>	Use to filter the files by status. Only the files with the selected status display.
<i>Use all files in this Dir. checkbox</i>	Select to include all files from the selected directory.

Start Report

Reports > Start Report (or use the F8 keyboard shortcut)

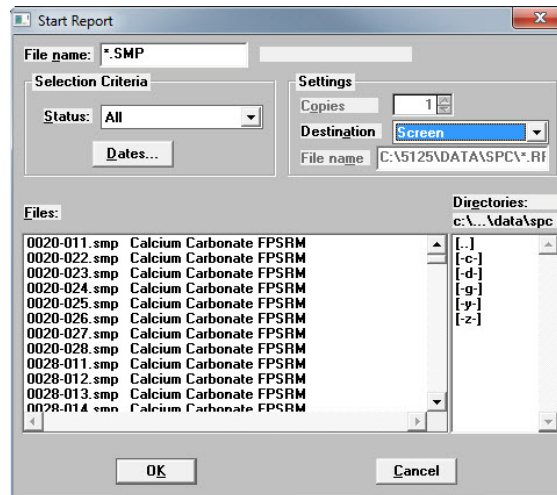

Use to generate a tabular and graphical reports on a sample analysis. Refer to [Common Fields and Buttons - Reports Menu Options](#), page 5-1 for a description of the fields and buttons.

Close Reports

Closes all open reports. This option is disabled if reports are being generated.

Baseline Reports

Reports > Baseline

A graphical report can be generated on an instrument’s baseline. This report generates a graph illustrating the X-ray intensity versus the cell height. The report header contains baseline statistics, such as the unit serial number, date the baseline was performed, etc.

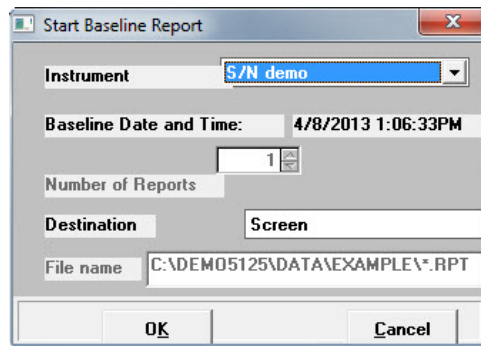

Field or Button	Description
<i>Instrument</i>	Displays a dropdown list of serial numbers of the attached instruments.
<i>Baseline Date and Time</i>	Displays the date and time of the last baseline measurement.
<i>Number of Reports</i> <i>Destination</i> <i>File name</i>	Refer to Settings group box in Common Fields and Buttons - Reports Menu Options , page 5-1.
<i>Cancel button</i> <i>OK button</i>	Refer to Common Fields and Buttons - Reports Menu Options , page 5-1.

SPC Report Options

Reports > SPC Report Options

Use to generate reports with various SPC (Statistical Process Control) options. All selected variables must be computed for each sample file used in an SPC report; therefore, it is more efficient to select only the necessary variables.

The selected items appear as options on the *Reports > Regression Report* screen as selections in the dropdown boxes and are used in graph selection in *Reports > Control Chart*.

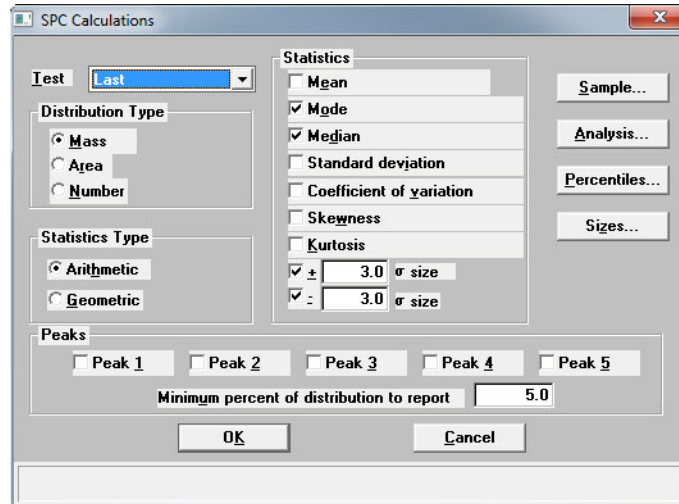

Field or Button	Description
<i>Test</i>	Analysis choices for SPC calculations. <ul style="list-style-type: none"> • Last - reports statistics for the last analysis in the sample file(s). • First - reports statistics for the first analysis in the sample file(s). • Average - reports an average based on all analyses in the sample file(s).
<i>Distribution Type group box</i>	Select the type of distribution data for computation of the SPC variables.
<i>Statistics group box</i>	Select the type of statistics for SPC variables calculations.

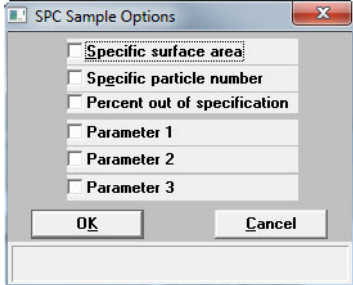
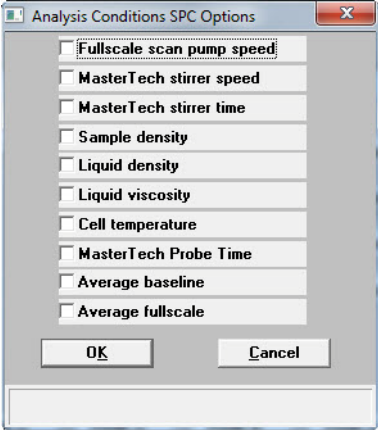
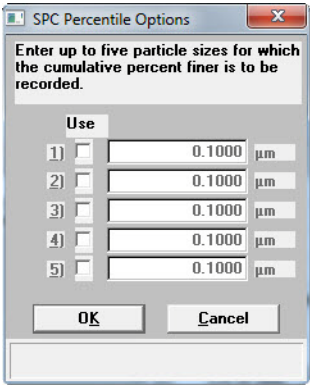
Field or Button	Description (<i>continued</i>)
<p><i>Sample button</i></p>	<p>Select the SPC Sample Options to include on the report. Refer to Sample Defaults, page 6-3 for information on the User Parameter fields.</p> 
<p><i>Analysis button</i></p>	<p>Select the SPC Analysis Options to include on the report.</p> 
<p><i>Percentiles button</i></p>	<p>Specify up to five particle sizes for which the cumulative percent finer is to be recorded.</p> 

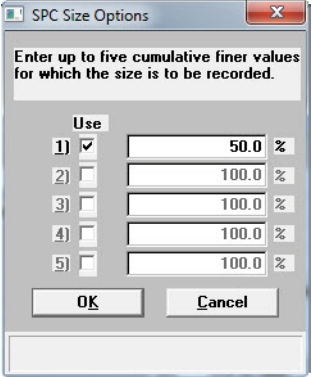
Field or Button	Description (<i>continued</i>)
<i>Sizes button</i>	<p>Specify up to five cumulative finer values for which the size is to be recorded.</p> 
<i>Peaks group box</i>	<p>Select up to five peaks to include in the SPC calculations. Enter the minimum percentage of the distribution in the text box.</p>
<i>Cancel button</i> <i>OK button</i>	<p>Refer to Common Fields and Buttons - Reports Menu Options, page 5-1.</p>

Regression Report

Reports > Regression Report

Use to generate an SPC (Statistical Process Control) Regression report to determine the interdependency between two variables. Up to three dependent variables (y-axis) may be plotted against a single independent variable (x-axis). The degree of correlation between the variables is also reported.

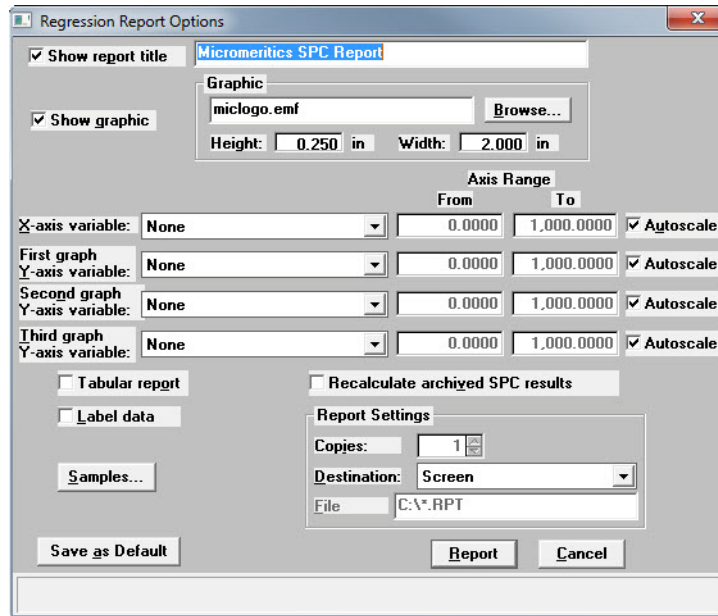

Field or Button	Description
<i>X- and Y-Axes / Variable fields</i>	<p>Designate the X- and Y-axes variables. Click the downarrow to display a list of variables specified in the SPC report options.</p> <p>Plot the regression of up to three Y-axis variables against the X-axis variable.</p> <ul style="list-style-type: none"> • X-axis - specifies the independent variable • Y-axis - specifies the dependent variables
<i>Axis Range</i>	<p>Specify the From and To values for the X- and Y-axis ranges. Data collected outside these ranges are not included in the plot. These fields are disabled if Autoscale is selected.</p>
<i>Autoscale</i>	<p>Scales the X- and / or Y-axes automatically. When scaled automatically, both axes begin at zero. The analysis program uses the highest values collected during analysis as the ending points.</p>
<i>Tabular report</i>	<p>Generates tabular and graphical data of the included samples. A tabular report contains the numeric values contributed by each sample.</p>

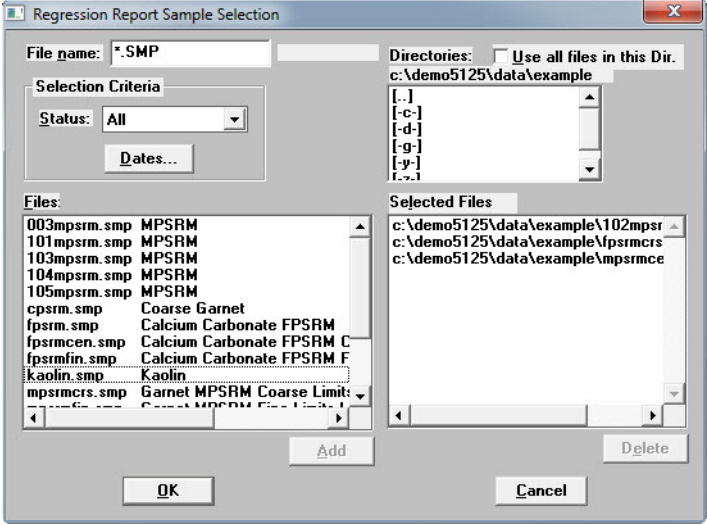
Field or Button	Description (<i>continued</i>)
<i>Label data</i>	Select to label the points on the plot to correspond with the values in the sample files.
<i>Samples button</i>	<p>Select the options to include on the report. Refer to Common Fields and Buttons - Reports Menu Options, page 5-1.</p> 
<i>Recalculate archived SPC results checkbox</i>	Use to have archived SPC values recalculated ensuring any changes made to the SPC Report Options are included in the new report. Selecting this option lengthens the time required to generate the report.
<i>Report Settings group box</i>	Refer to Settings group box in Common Fields and Buttons - Reports Menu Options , page 5-1.
<i>Save as Default button</i>	Saves the current definition of the report as the default.
<i>Browse button</i> <i>Cancel button</i> <i>OK button</i> <i>Show graphic</i> <i>Show report title</i>	Refer to Common Fields and Buttons - Reports Menu Options , page 5-1.

Control Chart

Reports > Control Chart

Use to generate an SPC (Statistical Process Control) control chart report which plots the changes in a statistic.

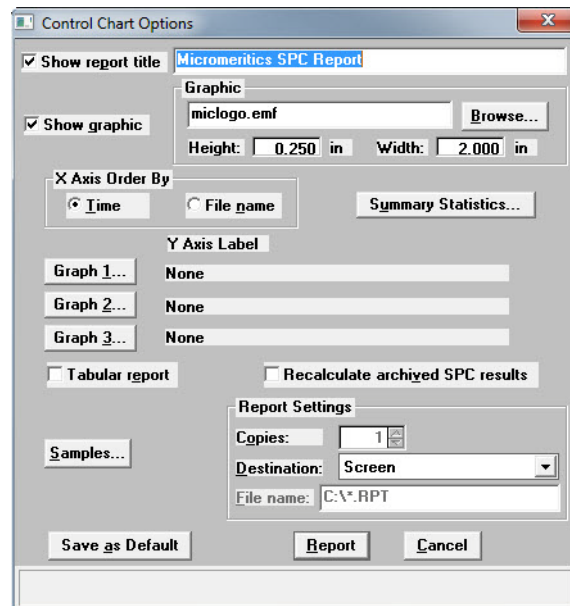

Field or Button	Description
<i>X-axis Order By group box</i>	Select the order in which x-axis statistics are placed. <ul style="list-style-type: none"> • Time - sorts by the time the files were analyzed. • File name - sorts in alphanumeric order.

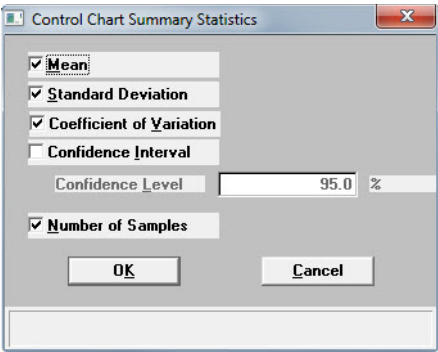
Field or Button	Description (<i>continued</i>)
<i>Summary Statistics button</i>	<p>Select the statistics to display in the report.</p>  <p>Select the statistics to display:</p> <ul style="list-style-type: none">• Mean• Standard Deviation• Coefficient of Variation - the Standard Deviation divided by the Mean• Confidence Interval - the confidence interval of the mean value shown on the same line below the graph on the report. Enter the percent in the Confidence Level field.• Number of Samples - select to have the number of samples analyzed included in the report

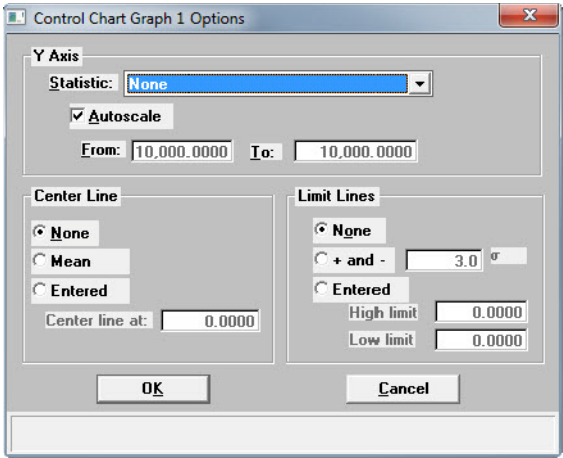
Field or Button	Description (<i>continued</i>)
<i>Graph [n] button</i>	<p>Click to define the Y-axis of each graph.</p>  <ul style="list-style-type: none"> • Statistic - displays the SPC variables selected on the SPC Report Options window. The selected variable will be plotted against time. • Autoscale - select to automatically the Y-axis scale. To specify a range, deselect this option and enter ranges in the From and To fields. • Center Line - displays placement options for the variable's optional value. Choose Entered to specify placement of the line. • Limit Lines - displays the options available for limiting lines. Lines can be placed at some multiple of the standard deviation or at specified positions (Entered). If Entered is selected, enter the High and Low limits.
<i>Tabular report checkbox</i>	Generates tabular and graphical data of the included samples. A tabular report contains the numeric values contributed by each sample.
<i>Recalculate archived SPC results checkbox</i>	Select to have archived SPC values recomputed. This ensures that changes made to the SPC Report Options are included in the new report. This option lengthens the time required to generate the report.

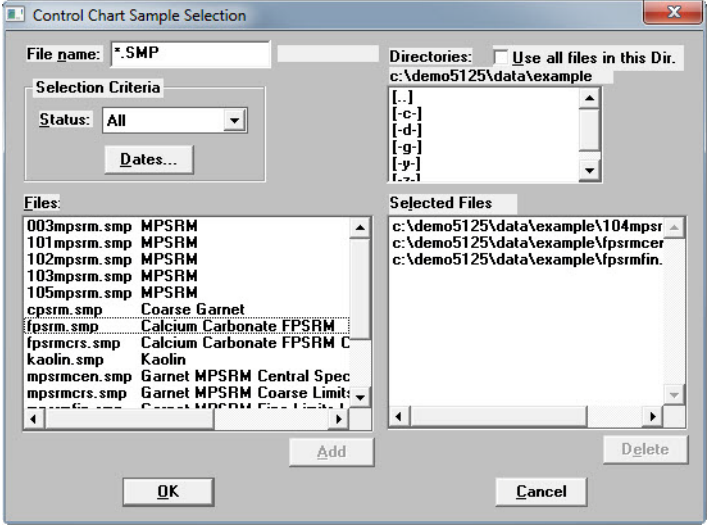
Field or Button	Description <i>(continued)</i>
<p><i>Samples button</i></p>	<p>Select the options to include on the report. Refer to Common Fields and Buttons - Reports Menu Options, page 5-1.</p> 
<p><i>Browse button</i></p> <p><i>Cancel button</i></p> <p><i>Dates button</i></p> <p><i>Delete button</i></p> <p><i>OK button</i></p> <p><i>Report Setting group box</i></p> <p><i>Show graphic</i></p> <p><i>Show report title</i></p>	<p>Refer to Common Fields and Buttons - Reports Menu Options, page 5-1.</p>

PSD History

Reports > PSD History

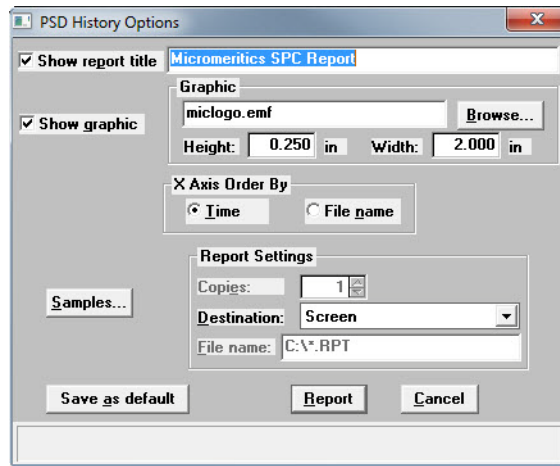

Used to report a sequence of full particle size distribution graphs.

Field or Button	Description
<i>X-axis Order By</i> group box	<p>Select the order in which x-axis statistics are placed.</p> <ul style="list-style-type: none"> • Time - sorts by the time the files were analyzed. • File name - sorts in alphanumeric order.
<i>Samples</i> button	<p>Select the options to include on the report. Refer to Common Fields and Buttons - Reports Menu Options, page 5-1.</p>

Field or Button	Description (<i>continued</i>)
<i>Browse button</i> <i>Cancel button</i> <i>Dates button</i> <i>Delete button</i> <i>OK button</i> <i>Report Setting group box</i> <i>Save as default button</i> <i>Show graphic</i> <i>Show report title</i>	Refer to Common Fields and Buttons - Reports Menu Options , page 5-1.

Report Features and Shortcuts

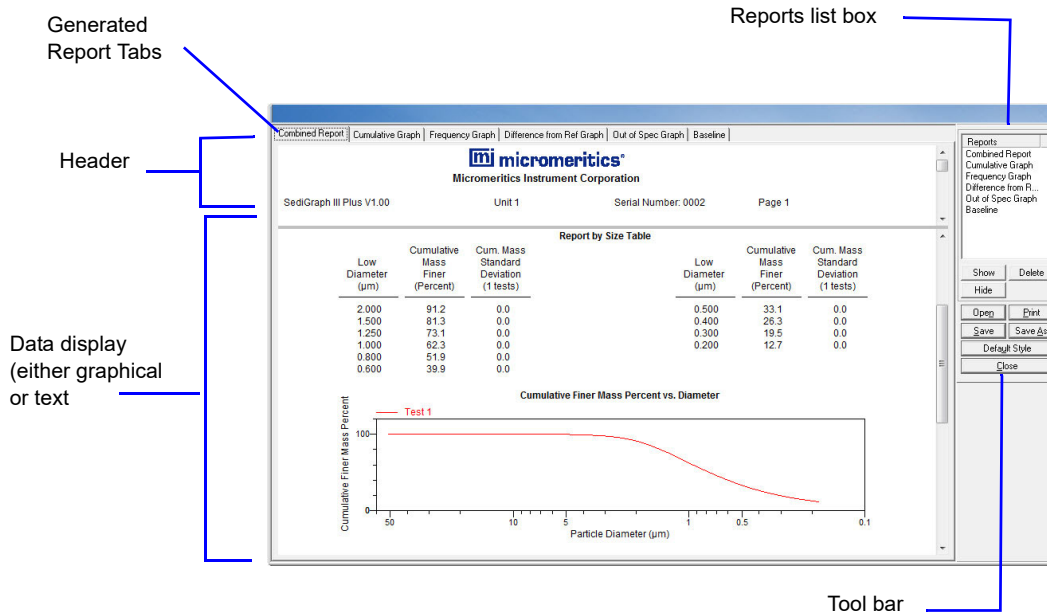

Report Header

All reports contain a header displaying file statistics.

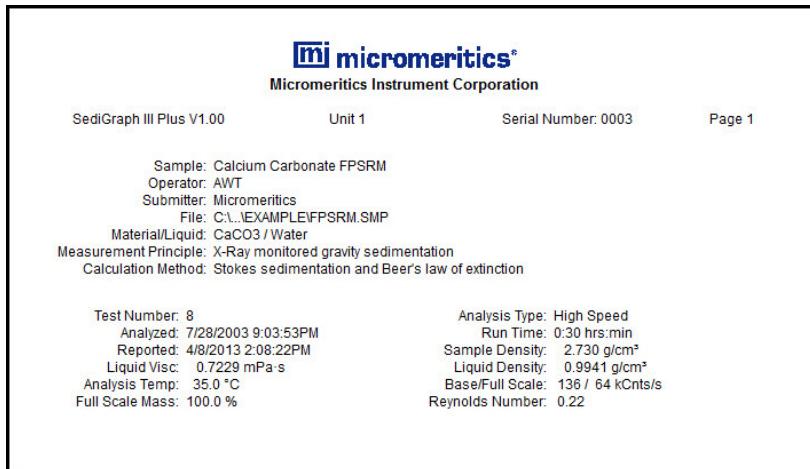

- If configured, the report header can also contain a graphic and a title. Tabular and graphical reports contain sample and instrument statistics such as analysis date / time, analysis conditions, etc.
- The headers contain notes of sample file changes occurring after analysis.
- Summary report headers contain the same information as tabular and graphical reports with the exception of notes.

Report Header Title.

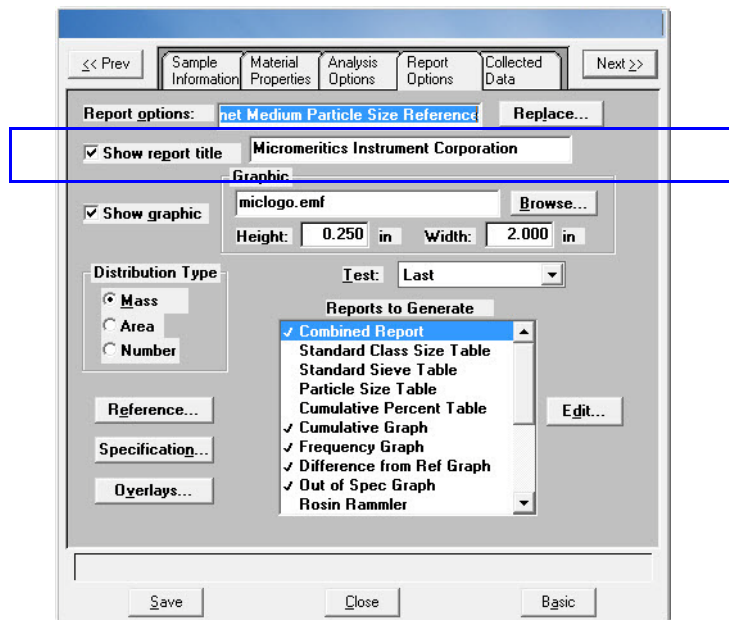

1. Open the file and select the **Report Options** tab.
2. Select the **Show report title** checkbox.
3. Enter the report title in the text box.

Report Header Graphic

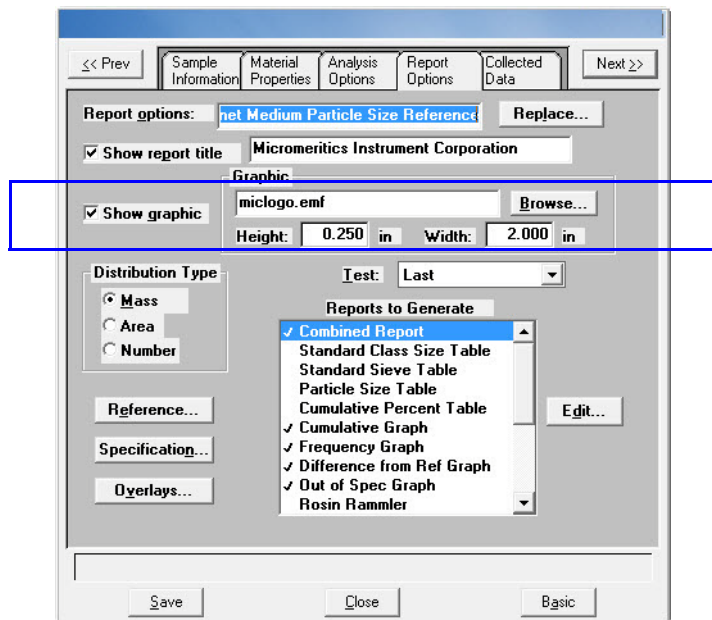

1. Open the file and select the **Report Options** tab.
2. Select the **Show graphic** checkbox.
3. Click **Browse** to locate the graphic.
4. Use the **Height** and **Width** to indicate the graphic size in inches.

Report Tool Bar

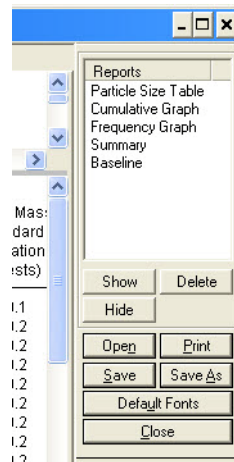

The **Report** window has a tool bar and selectable tabs across the top of the report header. To view a specific report, select its tab or select the report in the **Reports** list box and click **Show**.

Reports can be customized and manipulated using the tool bar, shortcut menus, the zoom feature, or axis cross-hairs.

Field or Button	Description
<i>Reports list box</i>	Contains a list of all generated reports. The same reports display as tabs across the top of the report header unless the report has been hidden using the Hide button.
<i>Show button</i>	<p>Jumps to the selected report in the Reports list box. Other methods to show reports are:</p> <ul style="list-style-type: none"> • Double-click the report name in the Reports list box • Select the report tab to show the report <p>If the report tab has been hidden using the Hide button, click Show to display the report and tab.</p>
<i>Delete button</i>	Deletes the selected report. Deleted reports will have to be regenerated if deleted in error.
<i>Hide button</i>	Hides (or temporarily removes) the selected report from the tabbed view. The report name remains in the Reports list box. To redisplay the tab, select the report in the Reports list box and click Show .

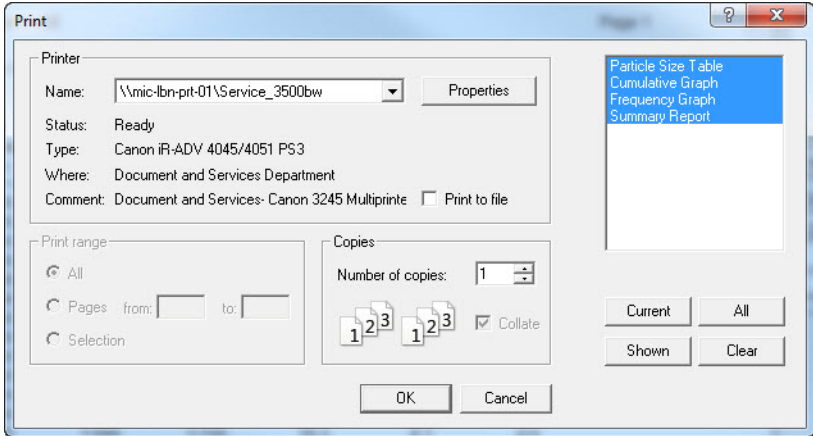
Field or Button	Description (<i>continued</i>)
Print button	<p>Displays the Print window for report output.</p>  <ul style="list-style-type: none"> • Name dropdown list and Properties button - select the printer and click the Properties button to change printer setup. • Print range group box - use to enter specific pages to print. • Copies group box - select the number of copies and collate option. • Current button - selects the active report (or selected tab). • All button - selects all reports in the Reports list box. • Shown button - selects only the reports not hidden. • Clear button - clears all selections. • OK button - prints the selected report to the printer indicated. • Cancel button - closes the Print window.
Save button	<p>Saves all reports of the active file using the sample file name with a .REP file extension.</p>
Save As button	<p>Saves all selected reports to the indicated file format:</p> <ul style="list-style-type: none"> • .REP (Report system) - saves the report in a format that can be opened with any MicroActive program. • .TXT (ASCII text) - saves the report as a common machine language file. • .XLS (Spreadsheet file) - saves the report in a spreadsheet format.

Field or Button	Description (<i>continued</i>)
<p>Default Style button</p>	<p>Click to specify default report parameters for fonts and curve properties.</p> <div data-bbox="662 323 1341 739" data-label="Image"> </div> <ul style="list-style-type: none"> Font Type list box - use to edit font type and attributes for the selected item. Select an item in the list, click Edit, and select from various font options. Click OK when done. <div data-bbox="716 911 1289 1365" data-label="Image"> </div>

Field or Button	Description (<i>continued</i>)
Default Style button (<i>continued</i>)	<ul style="list-style-type: none"> • Curve group box - <ul style="list-style-type: none"> – Thickness text box - enter a thickness number for the curve. – Histogram Fill dropdown list - select a histogram fill option from the list. • Graph border line thickness text box - enter a thickness number for the graph border. • Load button - click to load the last saved default settings. • Save button - click to save the changes as the new default settings. • Close button - click to close the window and save the changes for the current report.

Report Shortcut Menus

Shortcut menus are accessed by right-clicking on the report header or the report body displayed on the screen.

Report Header Shortcuts

Display header shortcuts by right-clicking in the report header.

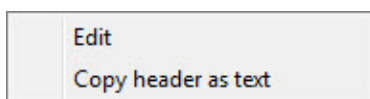

Option	Description
<i>Edit</i>	Use to edit the report title or graphic to display in the report header. Refer to Report Header , page 5-16 .
<i>Copy header as text</i>	Use to copy the report header as text. Text is copied to the clipboard and can then be pasted into other documents.

Tabular Reports Shortcuts

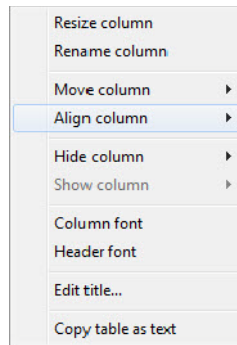

Display tabular report shortcuts by right-clicking in the body of the tabular report. Column shortcuts require right-clicking on the column to be modified.

Option	Description
<i>Resize column</i>	Right-click on the column to be resized. Select Resize Column on the shortcut menu and enter the new column width in inches.
<i>Rename column</i>	Right-click on the column to be renamed. Select Rename Column on the shortcut menu and enter the new column name.
<i>Move column</i>	Right-click on the column to be moved. Select Move Column on the shortcut menu and select Left or Right for the move.
<i>Align column</i>	Right-click on the column to be aligned. Select Align Column on the shortcut menu and select Left , Right or Center .
<i>Hide column</i>	Right-click on the tabular report and select which column(s) to hide.
<i>Show column</i>	Displays a list of all hidden columns. To display the hidden column, select it from the list.
<i>Column font</i>	Right-click in the report data. Select Column font on the shortcut menu. Deselect the Use default font to enable font options. Select new font attributes for the column data. To return to the default fonts, select the Use default font checkbox.
<i>Header font</i>	Right-click in the report data. Select Header font on the shortcut menu. Deselect the Use default font to enable font options. Select new font attributes for the header data. To return to the default fonts, select the Use default font checkbox.
<i>Edit title</i>	Use to edit the report title or graphic to display in the report header. Refer to Report Header , page 5-16 .

Option	Description (<i>continued</i>)
<i>Copy table as text</i>	Use to copy the report header as text. Text is copied to the clipboard and can then be pasted into other documents.

Graph Shortcuts

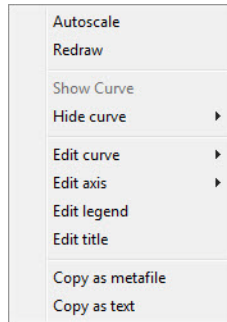

Display graph report shortcuts by right-clicking in the body of the graph report.

Option	Description
<i>Autoscale</i>	Returns the report to full view after using the zoom feature.
<i>Redraw</i>	Removes the cross-hair and returns the graph back to the initial setting.
<i>Show curve</i>	Displays a list of hidden curves. To show a curve, select it from the list.
<i>Hide curve</i>	Displays a list of curves. Select the curve to hide.
<i>Edit curve</i>	<p>Use to edit selected curve properties.</p> <div data-bbox="643 1323 1224 1812" data-label="Image"> </div> <ul style="list-style-type: none"> • Title text box - use to change the title of the selected curve.

Option	Description (<i>continued</i>)
<i>Edit curve (continued)</i>	<ul style="list-style-type: none"> • Style dropdown list - use to select another style for the collected data curve. • Curve group box - options are disabled if Histogram is selected in the Style dropdown list. Use to edit the curve interpolation, point style and pen style and color for the selected curve. <p>Color button - click to change the curve color.</p> <p>Use default thickness checkbox - select to use the default curve thickness. Deselect the checkbox and enter a new thickness number in the Thickness text box.</p> <ul style="list-style-type: none"> • Histogram group box - enabled only if Histogram is selected in the Style dropdown list. Use to specify the type of fill, fill color and label position for the selected curve. <p>Label dropdown list - select where the graph point labels will display (left, right, center, etc.) on the SPC report.</p>

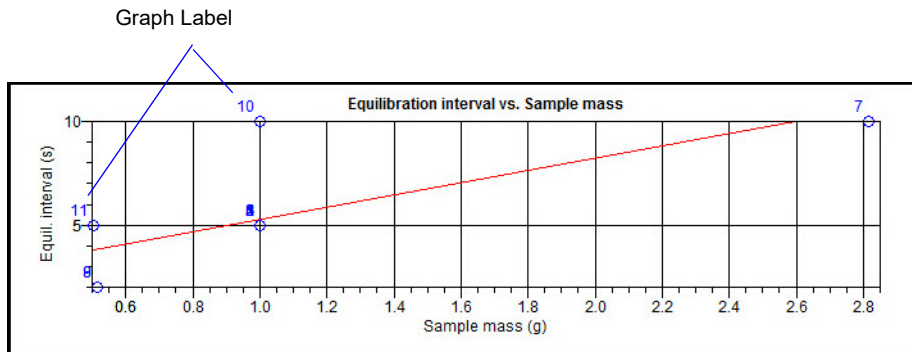

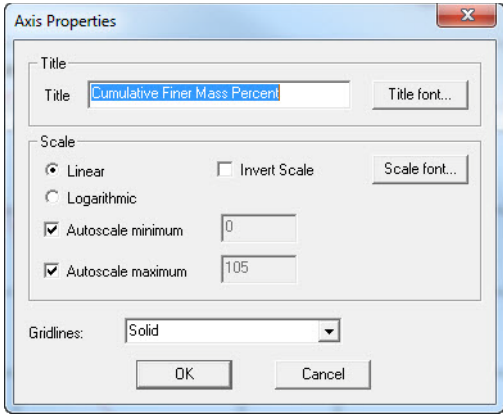
Option	Description (<i>continued</i>)
<i>Edit axis</i>	<p>Use to edit the selected axis properties.</p>  <ul style="list-style-type: none"> • Title group box - use to edit the selected axis label. <ul style="list-style-type: none"> Title text box - use to modify the label of the selected axis. Title font button - use to modify the font for the selected axis label. Deselect the Use default font to enable font options. Select the font attributes and click OK. • Scale group box - use to change the graph display. <ul style="list-style-type: none"> Linear / Logarithmic - select the option to scale the graph as linear or logarithmic. Autoscale minimum / maximum - select the Autoscale checkbox to enable the option. To manually specify minimum / maximum, deselect the Autoscale checkbox and enter the new amount in the text box. Invert scale checkbox - use to invert the scale. Scale font button - use to modify the font for the scale label. Deselect the Use default font to enable font options. Select the font attributes and click OK. Gridlines dropdown list - use to change how gridlines are displayed.

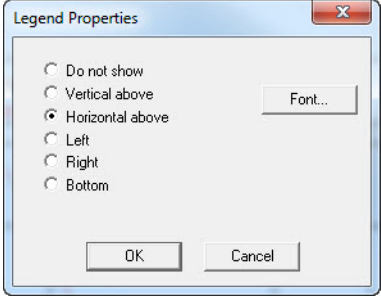
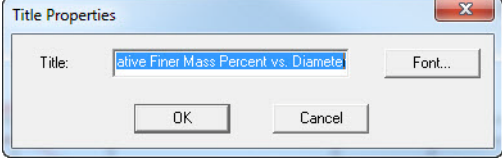
Option	Description <i>(continued)</i>
<i>Edit legend</i>	<p>Use to change the legend location and font. Click Font to modify legend fonts. Deselect the Use default font to enable font options.</p> 
<i>Edit title</i>	<p>Use to change the graph title and font. Click the Font button to change the font type and font style. Deselect the Use default font to enable font options. Refer to Default Style in the table in Report Tool Bar, page 5-19.</p> 
<i>Copy as metafile</i>	<p>Copies the graph to the clipboard. It can then be pasted into other applications.</p>
<i>Copy as text</i>	<p>Copies the report data to the clipboard. It can then be pasted into other applications as tab-delimited columns of text.</p>

Other On-Screen Features

Zoom Feature

Use the zoom feature to closer examine graph details. To use this feature:

1. Open the graph.
2. Hold down the left mouse button and drag the cursor across the graphical area to be enlarged. A box will display in the area to be enlarged.
3. Release the mouse button. The enlarged area fills the graph area. To return to normal view, right-click in the graph area and select **Autoscale** or **Redraw** on the shortcut menu.

Axis Cross-Hair

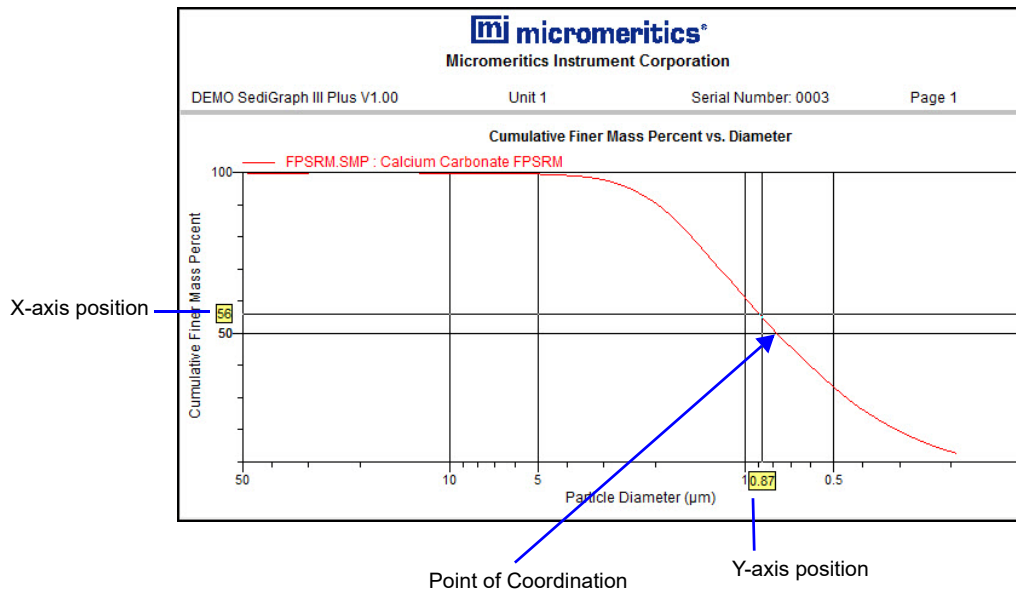

The cross-hair feature displays axis coordinates. To use this feature:

1. Click the left mouse button on the graph to view the cross-hair coordinates.
2. To remove the cross-hair, right-click in the graph area and select **Autoscale** or click out of the graph area.

Report Examples

This section contains examples of the types of reports available with the analysis program.

Combined Report

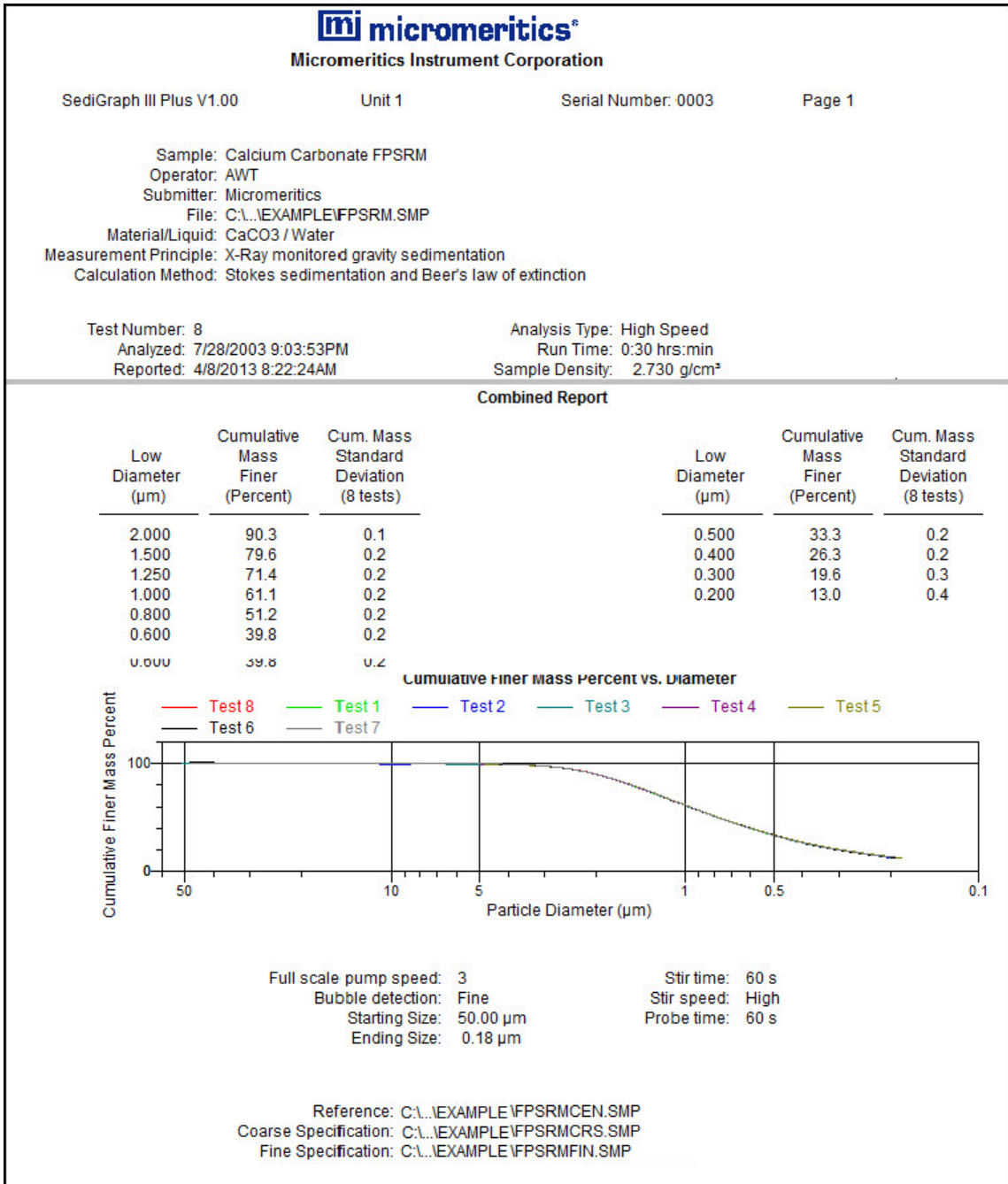

Report by Size Class

 Micromeritics Instrument Corporation					
SediGraph III Plus V1.00	Unit 1	Serial Number: 0003	Page 5		
Sample: Calcium Carbonate FPSRM Operator: AWT Submitter: Micromeritics File: C:\...EXAMPLE\FPSRM.SMP Material/Liquid: CaCO3 / Water Measurement Principle: X-Ray monitored gravity sedimentation					
Report by Size Class					
High Diameter (μm)	Low Diameter (μm)	Average Diameter (μm)	Cumulative Mass Finer (Percent)	Mass Frequency (Percent)	Cum. Mass Standard Deviation (8 tests)
48.70	45.97	47.32	99.8	0.0	0.4
45.97	43.40	44.67	99.8	0.0	0.4
43.40	40.97	42.17	99.8	0.0	0.4
40.97	38.68	39.81	99.8	0.0	0.3
38.68	36.52	37.58	99.8	0.0	0.3
36.52	34.47	35.48	99.8	0.0	0.3
34.47	32.55	33.50	99.8	0.0	0.3
32.55	30.73	31.62	99.8	0.0	0.3
30.73	29.01	29.85	99.8	0.0	0.2
29.01	27.38	28.18	99.8	0.0	0.2
27.38	25.85	26.61	99.9	0.0	0.2
25.85	24.41	25.12	99.9	0.0	0.2
24.41	23.04	23.71	99.9	0.0	0.2
23.04	21.75	22.39	99.9	0.0	0.1
21.75	20.54	21.13	99.9	0.0	0.1
20.54	19.39	19.95	99.9	0.0	0.1
19.39	18.30	18.84	99.9	0.0	0.1
18.30	17.28	17.78	99.9	0.0	0.1
17.28	16.31	16.79	99.9	0.0	0.1
16.31	15.40	15.85	99.9	0.0	0.1
15.40	14.54	14.96	99.9	0.0	0.2
14.54	13.72	14.13	99.9	0.0	0.2
13.72	12.96	13.34	99.8	0.0	0.2
12.96	12.23	12.59	99.8	0.0	0.2
12.23	11.55	11.89	99.7	0.0	0.2
11.55	10.90	11.22	99.7	0.0	0.2
10.90	10.29	10.59	99.7	0.0	0.2
10.29	9.716	10.00	99.7	0.0	0.2
9.716	9.173	9.441	99.8	0.0	0.2
9.173	8.660	8.913	99.8	0.0	0.1
8.660	8.175	8.414	99.8	0.0	0.1
8.175	7.718	7.943	99.8	0.0	0.1
7.718	7.286	7.499	99.8	0.0	0.1
7.286	6.879	7.079	99.8	0.0	0.2
6.879	6.494	6.683	99.7	0.0	0.2
6.494	6.131	6.310	99.7	0.1	0.2
6.131	5.788	5.957	99.6	0.1	0.2
5.788	5.464	5.623	99.5	0.1	0.2
5.464	5.158	5.309	99.5	0.1	0.2
5.158	4.870	5.012	99.4	0.1	0.2
4.870	4.597	4.732	99.3	0.1	0.2
4.597	4.340	4.467	99.2	0.1	0.2
4.340	4.097	4.217	99.1	0.1	0.2
4.097	3.868	3.981	99.0	0.1	0.2
3.868	3.652	3.758	98.8	0.2	0.1

Mass Frequency vs. Diameter Report

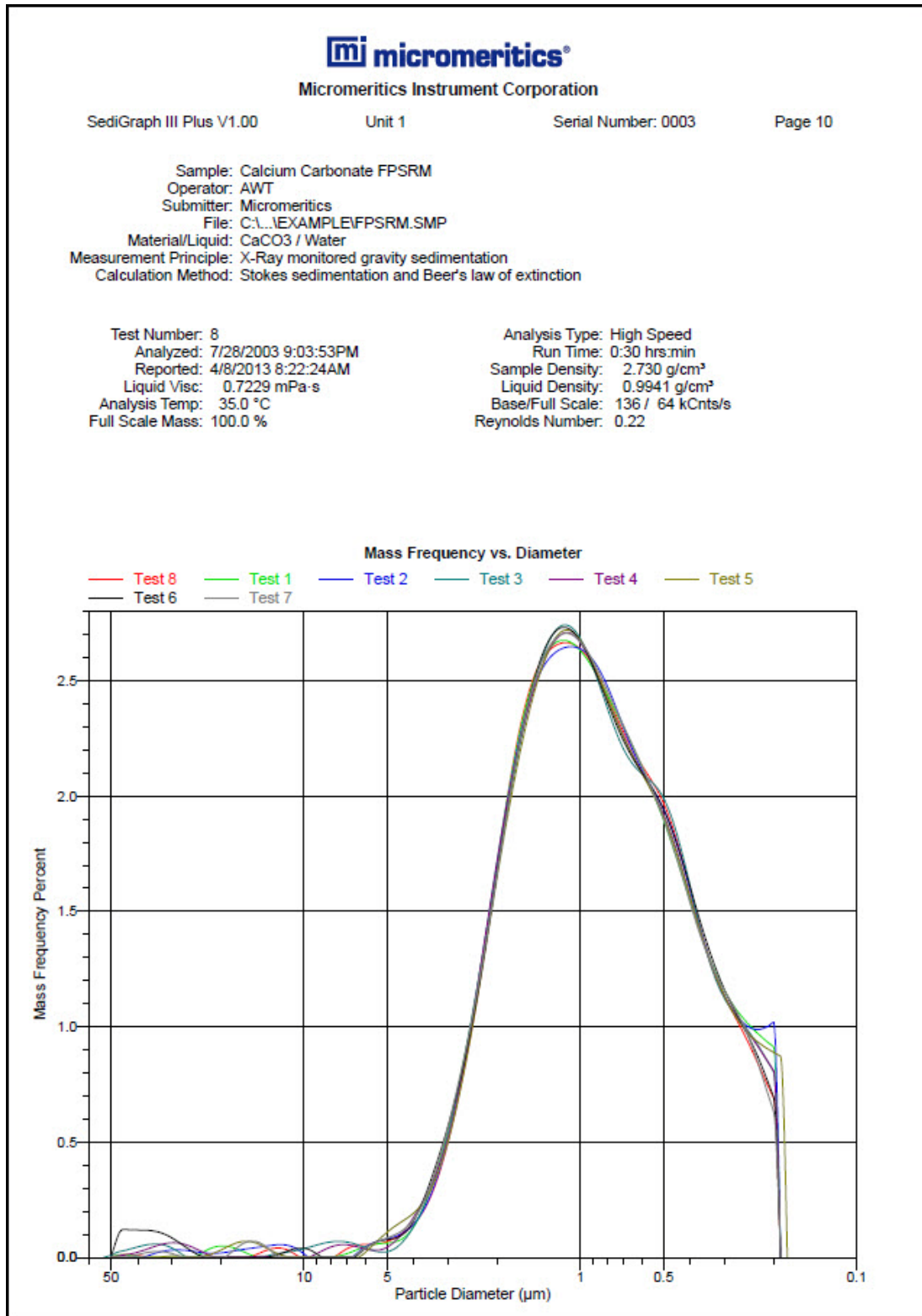

Rosin Rammler Graph

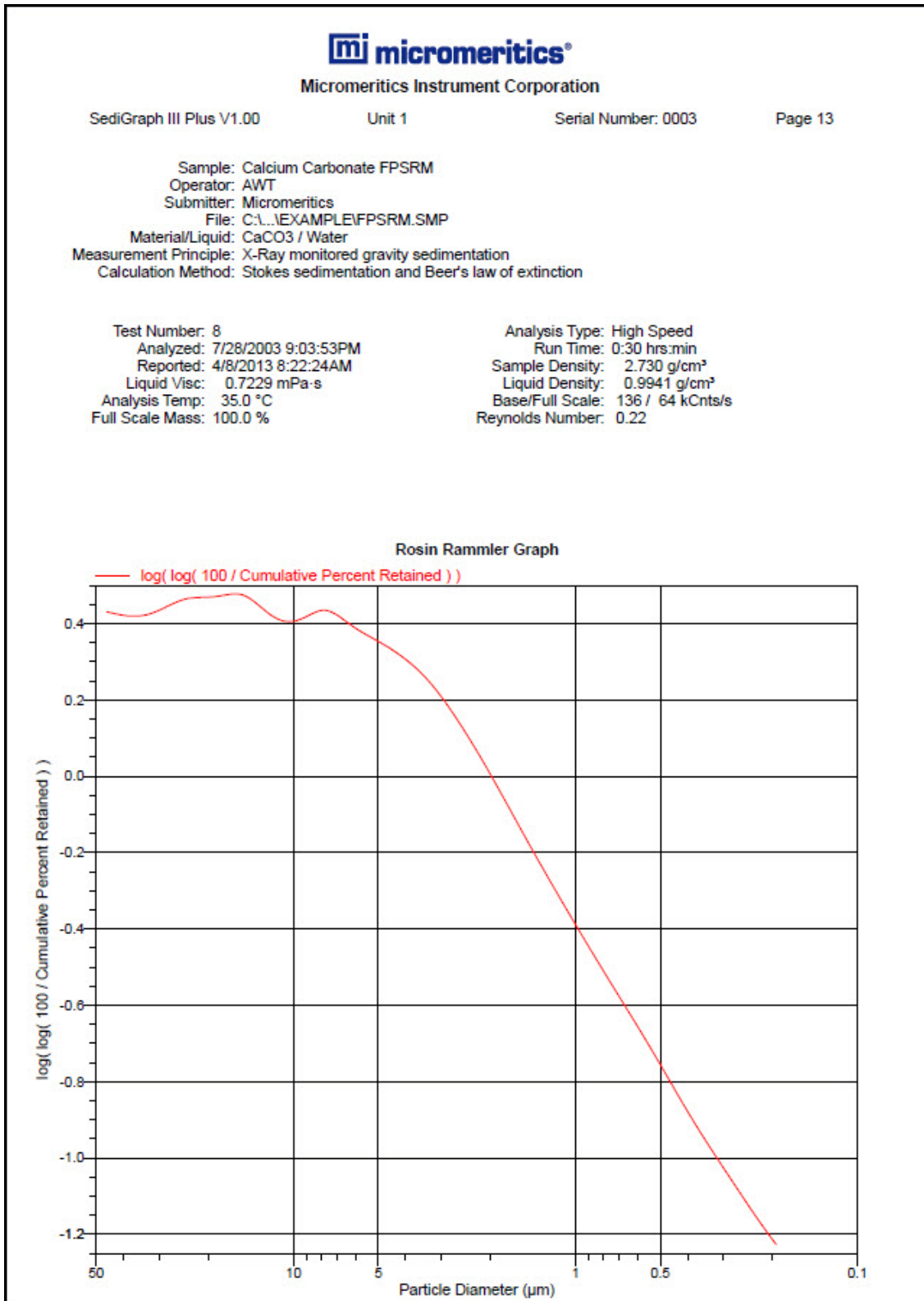

Summary Report

mi micromeritics®			
Micromeritics Instrument Corporation			
SediGraph III Plus V1.00	Unit 1	Serial Number: 0003	Page 2
<p>Sample: Calcium Carbonate FPSRM Operator: AWT Submitter: Micromeritics File: C:\...EXAMPLE\FPSRM.SMP Material/Liquid: CaCO3 / Water Measurement Principle: X-Ray monitored gravity sedimentation Calculation Method: Stokes sedimentation and Beer's law of extinction</p>			
Test Number: 8	Analysis Type: High Speed		
Analyzed: 7/28/2003 9:03:53PM	Run Time: 0:30 hrs:min		
Reported: 4/8/2013 8:22:24AM	Sample Density: 2.730 g/cm ³		
Liquid Visc: 0.7229 mPa·s	Liquid Density: 0.9941 g/cm ³		
Analysis Temp: 35.0 °C	Base/Full Scale: 136 / 64 kCnts/s		
Full Scale Mass: 100.0 %	Reynolds Number: 0.22		
Summary Report			
Starting Size: 50.00 µm	Probe time: 60 s		
Ending Size: 0.18 µm			
Parameter 1 0.000	Parameter 2 0.000	Parameter 3 0.000	
<p>Reference: C:\...EXAMPLE\FPSRMCEN.SMP Coarse Specification: C:\...EXAMPLE\FPSRMCRS.SMP Fine Specification: C:\...EXAMPLE\FPSRMFIN.SMP</p>			
6087- The Coarse/Fine specification file is invalid. No results available.			
Mass Distribution Arithmetic Statistics			
Median	0.778	Std Dev of 8 0.003	Std Dev of 8

Cumulative Surface Area Coarser vs. Diameter

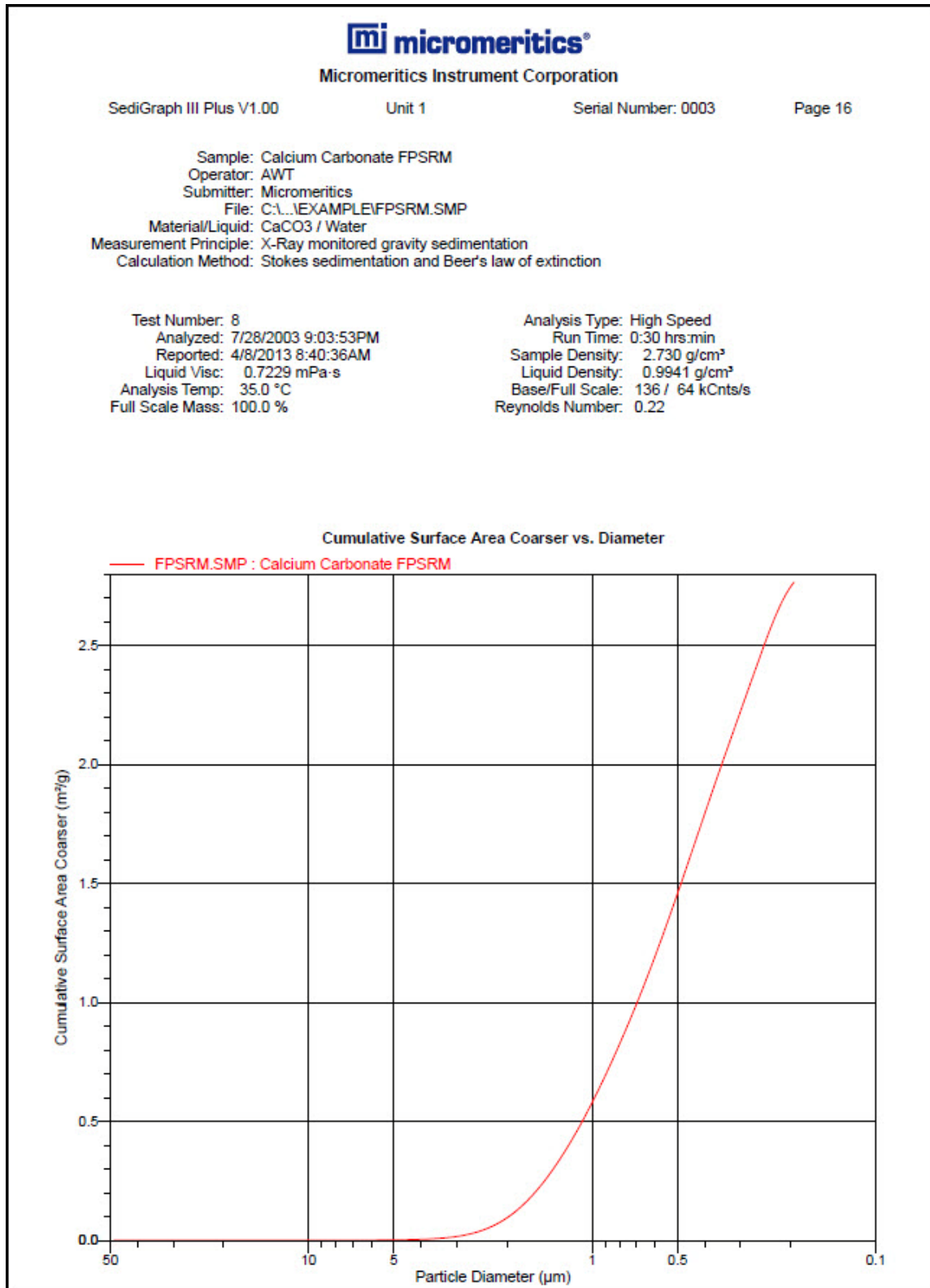

Surface Area Population vs. Diameter

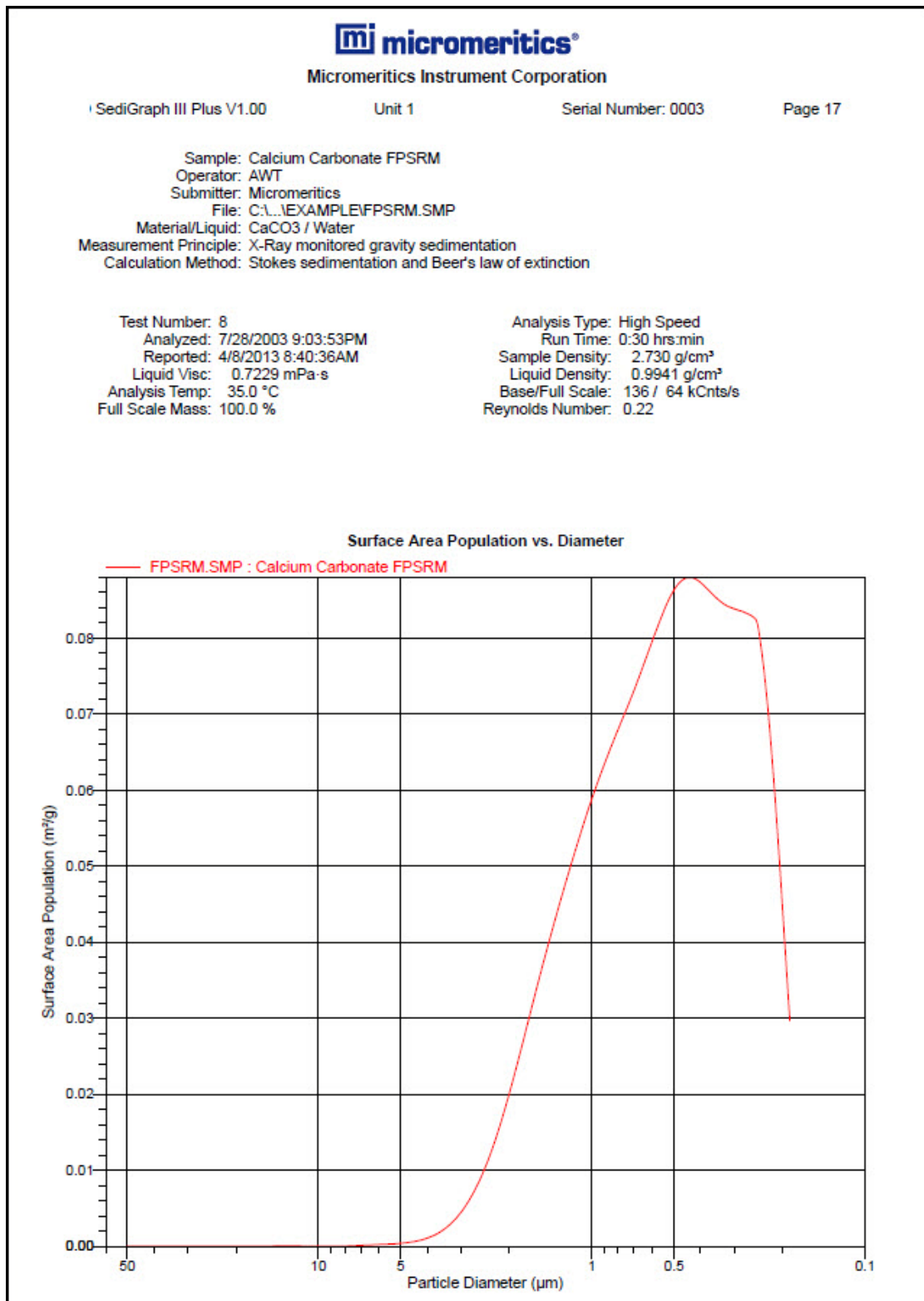

Cumulative Particle Number Coarser vs. Diameter

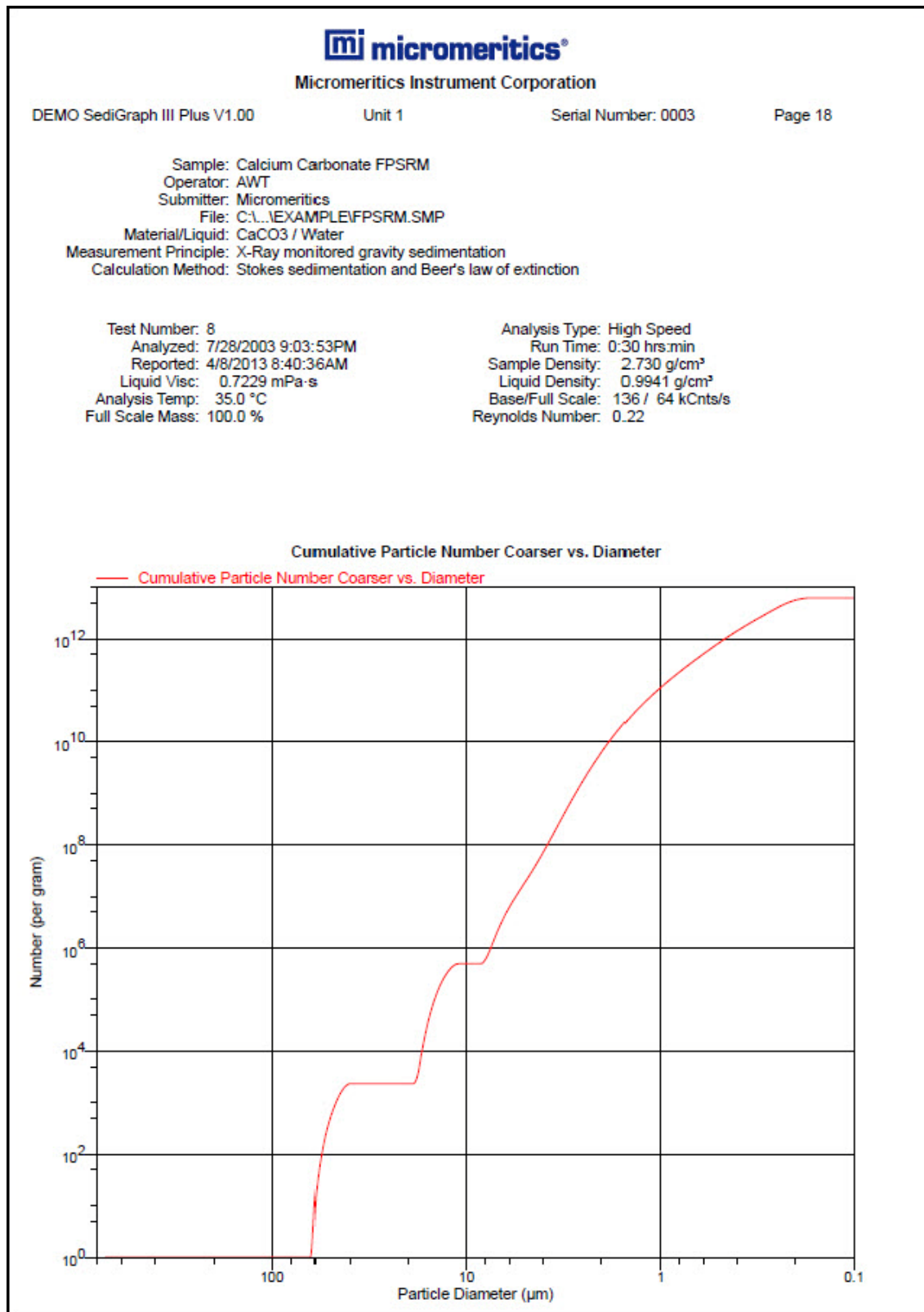

6. OPTIONS MENU

Introduction

This chapter contains information specific to the Options menu selections used to configure the system by setting defaults for sample and parameter files.

This chapter contains information on:

- changing the default presentation format - Restricted, Basic, or Advanced.
- specifying default parameters for sample information files and report option files.
- specifying how units appear on application windows and reports.

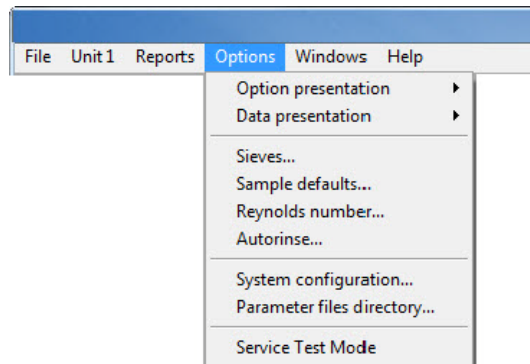

Option Presentation

Options > Option Presentation

Use to change the default editing format of sample files - Restricted, Basic, or Advanced. Each format type displays sample information and options differently. For descriptions of the presentation types, refer to [Creating Sample Files in Advanced Format](#), page 2-4. When using **Restricted** format, a password is required to change to **Advanced** format.

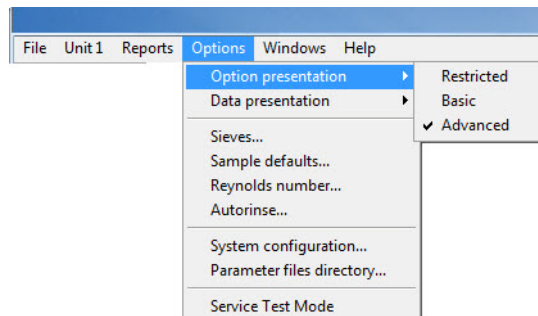

Data Presentation

Options > Data Presentation

The options on the Data presentation dropdown menu allow you to specify how tabular and graphical data to display on the screen and in printed reports.

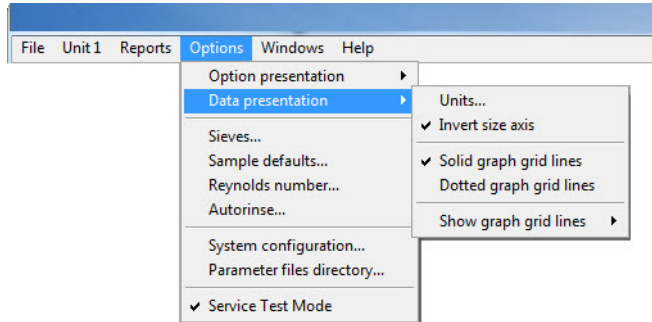

Field or Button	Description
<i>Units</i>	Select how data are to display on the screen and in printed reports. <div data-bbox="683 942 1312 1308" style="border: 1px solid gray; padding: 5px; margin: 10px auto; width: fit-content;"> </div>
<i>Invert size axis</i>	Inverts the size axis.
<i>Solid graph gridlines</i> <i>Dotted graph gridlines</i>	Select how graph gridlines display.
<i>Show graph gridlines</i>	Specify whether or not to have grid lines display on graphs and, if so, what type.

Sieves

Sieves specifies the default sieve sizes to use when sieve data are presented. The sieve sizes follow the technical specifications per ASTM Specification E-11.

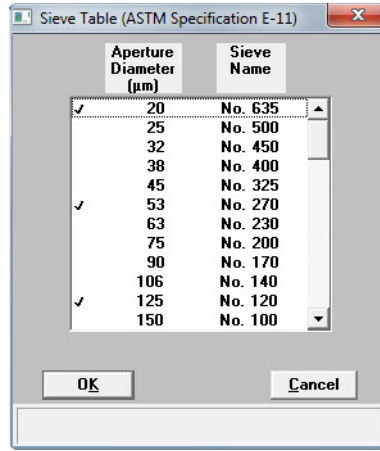

Double-click an entry to select it. A selected size is preceded by a check mark.

Sample Defaults

Options > Sample Defaults

Use to specify default parameters for sample information files. Refer to [Editing the Sample Default File](#), page 2-1.

Reynolds Number

Use to specify the Reynolds number to be used in estimating the maximum measurable diameter displayed on the **Material Properties** window.

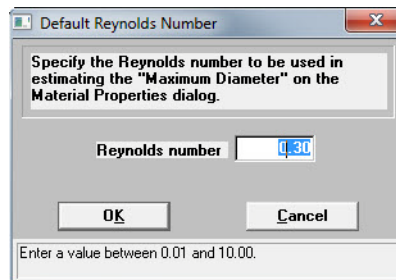

Autorinse

Use to specify autorinse options. The system default for Autorinse is 3 cycles of 3 rinses per cycle. The analyzer will rinse a maximum of 9 times in an attempt to reestablish baseline conditions before displaying an error message.

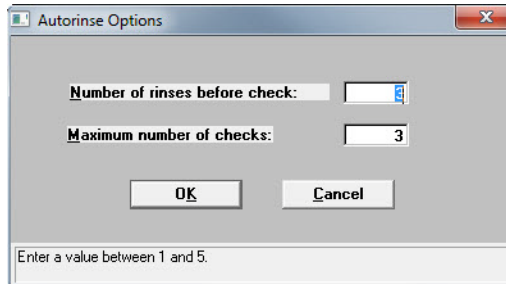

Field or Button	Description
Number of rinses before check	Enter the number of rinses per cycle to be performed after each analysis before baseline conditions are checked.
Maximum number of checks	Enter the maximum number of baseline checks to be performed before notification that baseline conditions have not been met.

System Configuration

Use to specify printer and plotter destinations for report output.

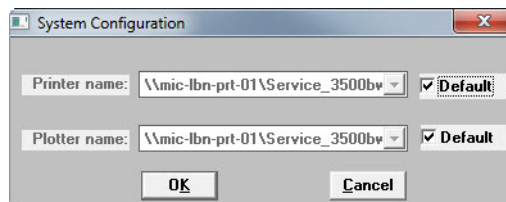

Field or Button	Description
<i>Printer name / Plotter name</i>	<p>The printer and plotter names are shown exactly as they appear in the operating system Print Manager.</p> <p>Select Default to use the default printer and plotter as designated in the Print Manager.</p> <p>To change the default printer, deselect Default. Then choose another printer (or plotter) from the dropdown list of installed printers (plotters).</p>

Parameter Files Directory

Options > Parameter Files Directory

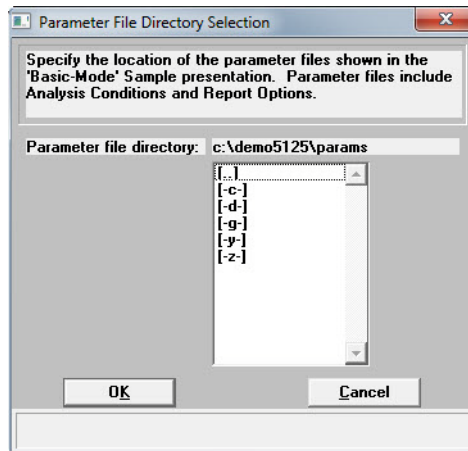

Use to select the location for the predefined parameter files displayed in the dropdown lists when in Basic or Restricted format. This configuration option is not available if using Restricted format. The system default directory is the recommended location for saving report options files. The default directory is **Params** and includes several parameter files supplied with the analysis software.

Service Test Mode

Options > Service Test Mode

Service Test Mode is a password protected option used to perform certain service tests with the assistance of a trained Micromeritics service representative. This password is supplied by your service representative. After Service Test Mode has been enabled, the tests are accessible from the Unit menu (*Unit > Service Test*).

7. TROUBLESHOOTING AND MAINTENANCE

Introduction

The analyzer has been designed to provide efficient and continuous service; however, certain maintenance procedures should be followed to obtain the best results over the longest period of time. This chapter includes maintenance and calibration procedures.

Troubleshooting

Most operational problems are caused by:

- deteriorated or blocked tubing
- air leaks
- an unlevel analyzer

When unexpected analysis results occur, check the above items first. Some common operational problems not indicated on the screen and their respective causes and solutions are provided in the following table:

What Happened	Why	What To Do
SediGraph		
Cell cannot be filled or drained.	Blocked or damaged tubing.	Locate and replace blocked or damaged tubing. Refer to Replacing Flexible Tubing , page 7-10.
	Blocked cell input or output port.	Clean analysis cell. Refer to Cleaning the Analysis Cell , page 7-8.
	Valve or pump not working properly.	From Manual Control screen, check pump and valve operation. If either is not working properly, contact authorized service personnel.
	Tubing improperly installed.	Install the tubing as described under Replacing Flexible Tubing , page 7-10

What Happened	Why	What To Do <i>(continued)</i>
Cell cannot be raised or lowered	Elevator which moves cell is stuck.	Check flexible tubing for possible obstruction to elevator movement. If necessary, reposition tubing. Also check for any other obstruction to elevator movement.
Mixing chamber cannot be filled or drained.	Blocked or damaged tubing.	Locate and replace blocked or damaged tubing. Refer to Replacing Flexible Tubing , page 7-10.
	Blocked mixing chamber input or output port.	Clean mixing chamber. Refer to Cleaning the Mixing Chamber and Bezel , page 7-6.
	Valve or pump not working properly.	From Manual Control screen, check pump and valve operation. If either is not working properly, contact authorized service personnel.
	Tubing improperly installed.	Install the tubing as described under Replacing Flexible Tubing , page 7-10.
Mixing chamber suspension is turning brown	Teflon [®] coating on stirring bar is worn.	Replace stirring bar. Refer to ORDERING INFORMATION , page 8-1.

What Happened	Why	What To Do (<i>continued</i>)
X-RAY ON indicator is turned on, but the computer display shows 0 kilocounts.	Analysis compartment door not completely closed.	Close analysis compartment door.
	Cell is in a position which blocks beam.	Move cell to proper operating position. Enable Manual Control, access the pop-up menu on the cell, and select <i>Move Cell Position</i> .
	Cell is clogged.	Remove and clean cell. Refer to Cleaning the Analysis Cell , page 7-8.
	Slits in collimator blocked.	Clean the collimator. Refer to Cleaning the Collimating Slits , page 7-18.
	X-ray source or detector has failed.	Contact authorized service personnel.
X-RAY STANDBY indicator was turned on, but when keyswitch is placed in X-RAY ON position, X-RAY ON indicator does not turn on.	Keyswitch is between positions.	Move keyswitch to X-RAY STANDBY position and then back to X-RAY ON position while observing indicator.
	X-RAY ON indicator lamp is burned out.	Replace lamp. Refer to Replacing the X-Ray Indicator Lamps , page 7-20.
	X-ray filament supply not available or X-ray unit damaged.	Contact authorized service personnel in accordance with service contract.
	Rear panel is off, the top cover is off, or the fluid module is not fully installed.	Replace all panels.
	First refer to Determining the Cause of Bubbles , page 7-23 and perform the outlined procedure. Then return to this table for corrective action.	

What Happened	Why	What To Do <i>(continued)</i>
Bubble elimination problem	Windows are dirty or misaligned.	Clean or replace the windows. Refer to Cleaning the Analysis Cell , page 7-8.
	Inlet port on the cell assembly is loose.	Replace the cell assembly. Refer to Replacing the Analysis Cell Assembly , page 7-22.
	A valve has failed.	Contact authorized service personnel.
<i>MasterTech</i>		
Power failure.	Power cable not connected or switch not in ON position.	Make sure power cable is plugged into the power source and the power ON/OFF switch is in the ON position.
	Input power fuse blown.	Replace the fuse. Refer to Replacing the MasterTech Input Power Fuse , page 7-24.
Stirrer will not work.	Stirrer is improperly connected.	Check the stirrer's electrical connection.
Turntable will not move.	Arm is in the LOAD position.	Press the AUTO/LOAD switch on the front panel to lower the arm.
MasterTech pump will not run.	Pump switch on the front panel may be in the OFF position.	Press the pump AUTO/ OFF switch on the front panel.
Ultrasonic probe will not work.	Probe improperly connected to the MasterTech.	Check the MasterTech connector cable.
Ultrasonic agitation diminished.	The ultrasonic probe tip may need replacing.	Refer to Replacing the Ultrasonic Probe Tip , page 7-24.
MasterTech will not initiate commands from the computer.	The cable may be connected improperly from the MasterTech to the computer.	Check the cable connections.

What Happened	Why	What To Do <i>(continued)</i>
Pump leaks or is not operating efficiently.	Tubing is leaking or clogged.	Refer to Replacing Flexible Tubing , page 7-10.

Preventive Maintenance

The following procedures should be performed every 12 months by a Micromeritics service technician. Do not attempt to perform these procedures yourself.

- Clean the high voltage area
- Calibrate the X-ray control system
- Calibrate the fluid control system
- Calibrate the temperature control system

Schedule

The following table lists the preventive maintenance procedures that should be performed to keep the analyzer operating at peak performance. (These procedures are also performed by your service technician at the same time as the ones listed above.) Instructions for each procedure follow the table.

Maintenance Required	Frequency	Refer to Page
Perform a reference material run	Every week	7-6
Clean the analyzer	Every 30 days*	7-6
Clean the mixing chamber and bezel	As needed	7-6
Clean the analysis cell	Every 30 days*	7-8
Replace the mixing pump and cell pump tubing	Every 30 days*	7-10
Replace the analysis cell tubing	As needed	7-14
Clean the air filter	Every 30 days*	7-15
Check the operation of the mixing pump	Every 30 days*	7-16
Check the operation of the cell pump	Every 30 days*	7-17
Check the level of the analyzer	Every 30 days*	7-18
Clean the collimating slits	As needed	7-18
*Or every 160 analyses, whichever comes first		

Performing a Reference Material Analysis

It is a good practice to perform a reference material analysis every week to ensure that the analyzer is operating within specifications. Reference material kits, including instructions for performing the reference material analysis, are available from Micromeritics. Refer to **ORDERING INFORMATION**, page **8-1**.

Cleaning the Analyzer

A clean cloth, dampened with isopropyl alcohol (IPA), a mild detergent or a 3% Hydrogen Peroxide solution may be used to clean the outside casing of the analyzer. It is not necessary to remove any control knobs or screws while cleaning. If a MasterTech is installed, clean it in the same manner.



Isopropyl alcohol (IPA) should not be used to clean the sliding door to the analysis compartment.

Cleaning the Mixing Chamber and Bezel

The mixing chamber bezel should be cleaned periodically to prevent contaminants from entering the mixing chamber. To clean the bezel:

- Remove the bezel and clean using a mild detergent. Rinse, then dry thoroughly before replacing it on the mixing chamber.

The mixing chamber should be removed and cleaned periodically to remove any residue.



When cleaning the mixing chamber, avoid getting the electrical connections wet. Do not immerse the chamber in liquid. Doing so could damage the system.

1. Drain the mixing chamber.
 - a.) Go to *Unit [n] > Drain and load*.
 - b.) Select **Leave mixing chamber empty**. Click **Continue**.
 - c.) When prompted to load the sample, click **Cancel**.

2. Disconnect the flexible tubing from the mixing chamber, exercising caution to prevent damage to the tubing. Disconnect the electrical cable.



3. Clean the chamber using IPA or a mild detergent. Rinse thoroughly. All ports should be cleaned using an air blower.
4. Reconnect the tubing to the mixing chamber. Refer to [Reconnecting the Mixing Chamber Tubing](#), page 7-7.

Reconnecting the Mixing Chamber Tubing

1. Attach the tubing to the mixing chamber.

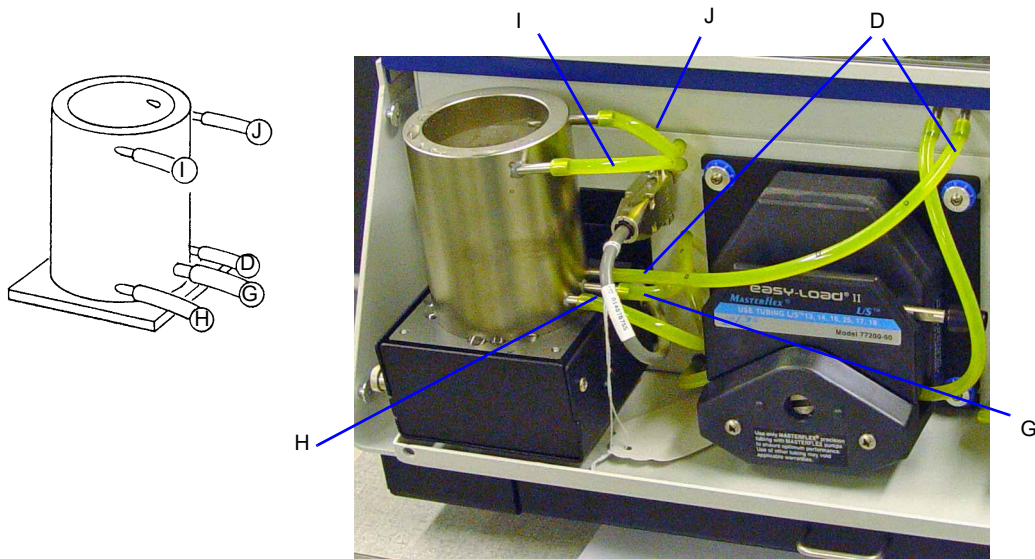

2. Ensure the tubing is securely fastened at each port.
3. Reconnect the electrical cable.

Cleaning the Analysis Cell

The analysis cell should be removed periodically and cleaned to remove any residue.

1. Go to *Unit [n] > Drain and load*.
2. Select **Leave mixing chamber empty**. Click **Continue**.
3. When prompted to load the sample. Click **Cancel**.
4. Place the Pump Control switch on the analyzer front panel in the OFF position.
5. Open the transparent sliding door to the analysis compartment. Loosen the cell mounting screw and remove the cell from the retaining bracket.

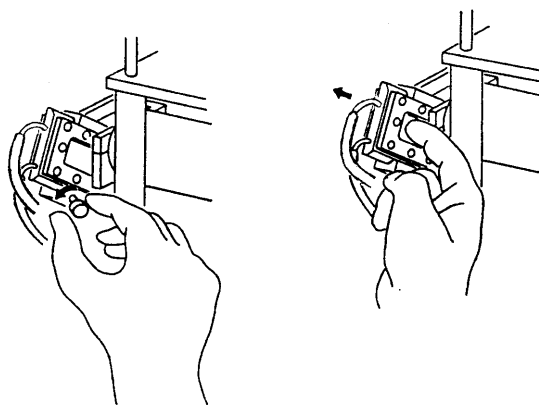

6. Carefully remove the flexible tubing from the rigid tubing connector which is mounted along the right side of the analysis compartment.
7. Carefully remove the flexible tubing from the two ports on the cell.

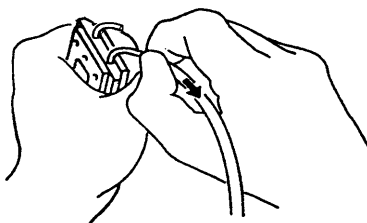

8. Disassemble the cell by removing the ten screws in the cell window retaining plates.

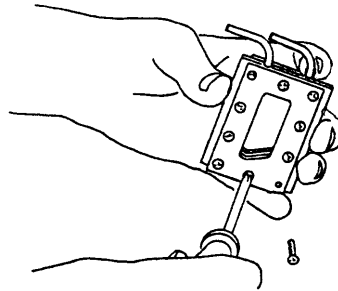

Do not use cloth made of a coarse material or abrasive cleansers when cleaning the cell windows. Particles may lodge in scratches, which could alter X-ray pulse rates and cause invalid analysis results.

9. Use either IPA or a mild detergent to clean the cell windows. Use an air blower to remove any debris from the cell body, window retaining plates, and ports.
10. Assemble the cell by placing a cell window and a cell window retaining plate on each side of the cell body. The cell window retaining plate must be positioned so that the sloped part matches that of the cell body and other plate.

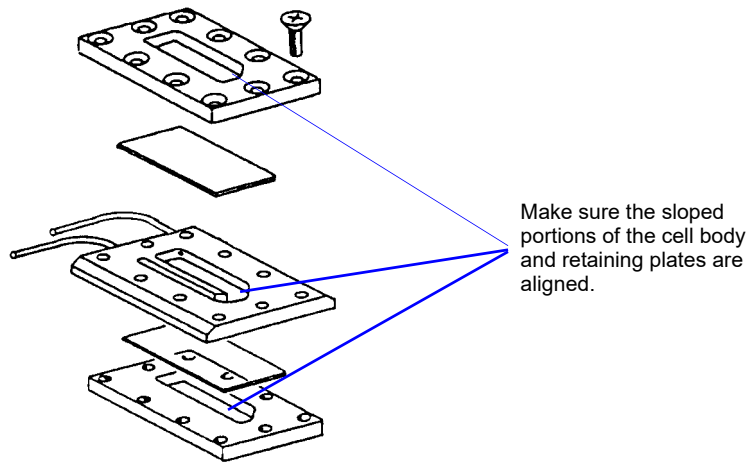

11. Insert the ten screws removed in step 8 into the window retaining plates, **but do not tighten**.



When assembling the cell, alternate the tightening of screws. Failure to do so could result in air entering the cell, causing bubble elimination problems.

12. Using a screwdriver, tighten the screws around the cell by tightening one screw and then tightening the screw diagonally opposite that screw. Refer to the following illustration for the tightening sequence. This sequence helps to ensure uniform closure around the cell.

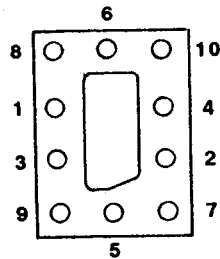

Torque to 9 in-lbs using the order shown on the illustration

13. Connect the flexible tubing to the ports on the analysis cell and to the rigid tubing connector. The tubing for the front port of the cell connects to the front rigid tubing connector. The tubing for the rear port of the cell connects to the rear rigid tubing connector.
14. Insert the cell in the retaining bracket and tighten the cell mounting screw.
15. Place the Pump Control switch in the ON position.
16. Go to *Unit [n] > Rinse > SediGraph*.

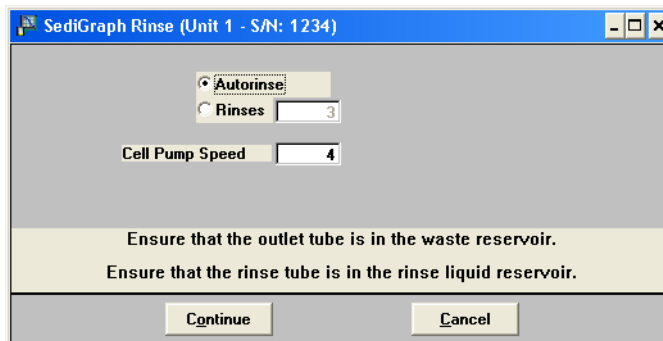

17. Select **Autorinse**. Click **Continue** to rinse the analysis cell.

Replacing Flexible Tubing

The analyzer includes a complete plumbing system for circulation of sedimentation liquid and particle suspension between the cell, the mixing chamber, an external rinse container, and an external waste container. In order for the system to operate properly, you must replace damaged or deteriorated tubing. You can replace tubing from the mixing pump, the cell pump, and the analysis cell independently.



The tube installation tool included in the instrument accessories may be used to help install the tubing.

When replacing tubing, always drain the system first. Refer to [Draining the System](#), page 7-11.

Draining the System

1. Ensure that the outlet tube is in the waste reservoir and the rinse tube is in the rinse liquid reservoir.
2. Go to *Unit [n] > Drain and load*.

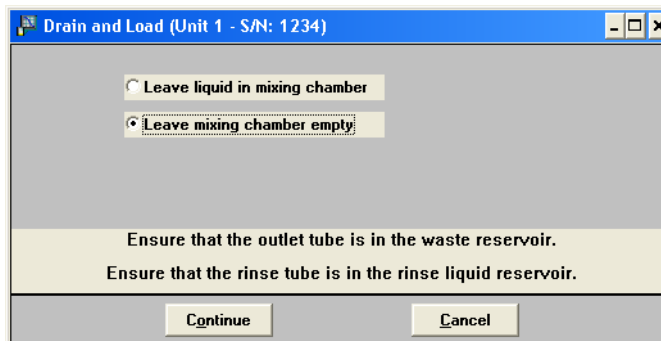

3. Select **Leave mixing chamber empty**. Click **Continue**. A progress message displays.

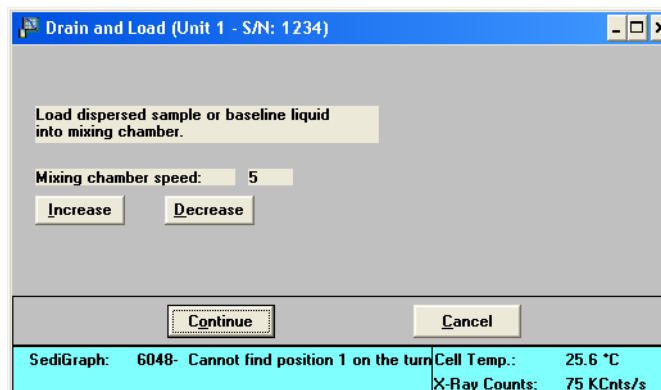

4. Click **Cancel**.

Replacing the Mixing Pump Tubing

1. Place the analyzer on the edge of a table or flat surface.
2. Remove the pump chassis cover.
3. Drain the system. Refer to [Draining the System](#), page 7-11.
4. Place the Pump Control switch on the analyzer front panel in the OFF position.
5. Rotate the mixing pump lever to the left (the mixing pump is the pump on the right) to place the mixing pump housing in the open position.

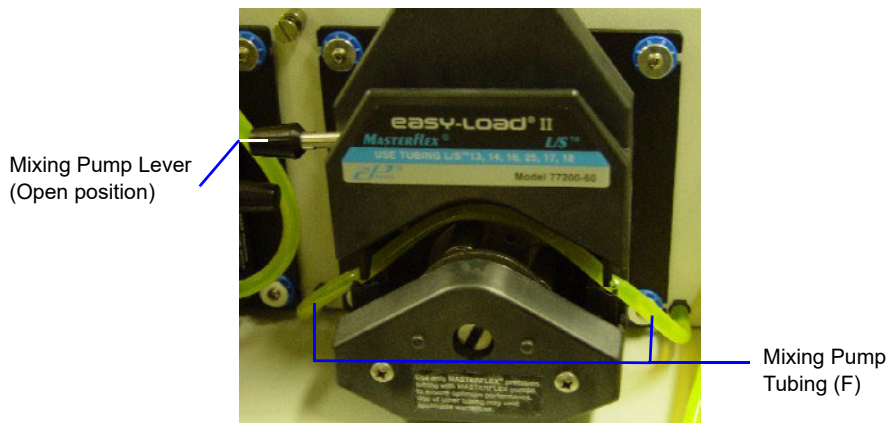

6. Remove the mixing pump flexible tubing from the rigid tubing connectors on both sides of the pump. Discard the used tubing.
7. Using the tube installation tool supplied in the accessories kit, attach one end of the new flexible tubing (labeled F) to the rigid tubing connector on the right.
8. Thread the tubing through the pump as shown below.



9. Attach the other end of the tubing to the rigid connector on the left.
10. Rotate the mixing pump lever to the right to place the mixing pump housing in the closed position.
11. Replace the pump chassis cover.
12. Place the Pump Control switch on the analyzer front panel in the ON position.

Replacing the Cell Pump Tubing

1. Place the analyzer on the edge of a table or flat surface.
2. Remove the pump chassis cover.
3. Drain the system. Refer to [Draining the System](#), page 7-11.
4. Place the Pump Control switch on the analyzer front panel in the OFF position
5. Rotate the cell pump lever (the cell pump is the pump on the left) to the left to place the cell pump housing in the open position.

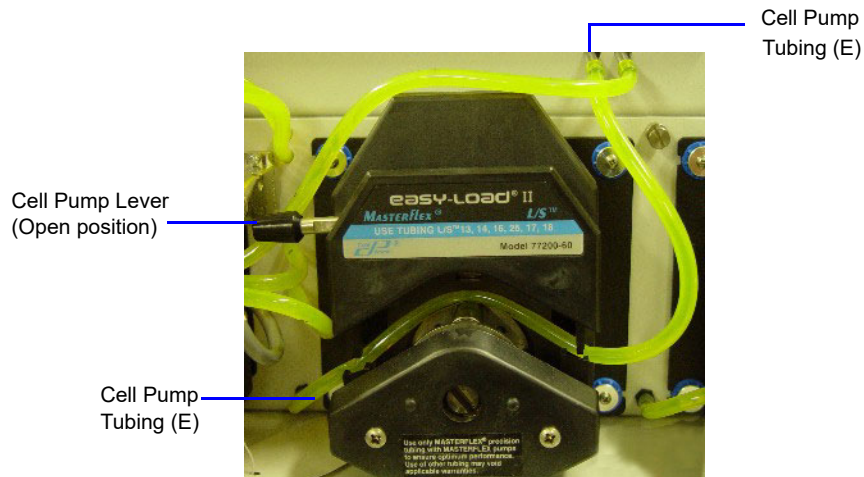

6. Remove the cell pump flexible tubing from both connectors; discard the used tubing.
7. Using the tube installation tool supplied in the accessories kit, attach one end of the new flexible tubing (labeled E) to the rigid tubing connector on the left side of the pump.
8. Thread the tubing through the pump as shown below.



9. Attach the other end of the tubing to the connector on the right side.
10. Rotate the cell pump lever to the right to place the cell pump housing in the closed position.
11. Replace the pump chassis cover.
12. Place the Pump Control switch on the analyzer front panel in the ON position.

Replacing the Analysis Cell Tubing

1. Drain the system. Refer to **Draining the System**, page 7-11.
2. Place the Pump Control switch on the analyzer front panel in the OFF position
3. Open the transparent sliding door to the analysis compartment.

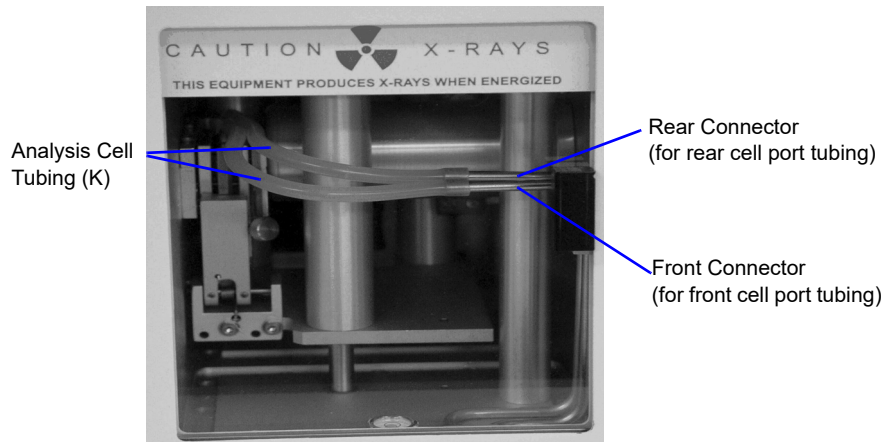

4. Remove the flexible tubing from the rigid tubing connector in the analysis compartment.
5. Loosen the cell mounting screw and remove the cell from the retaining bracket as shown below.

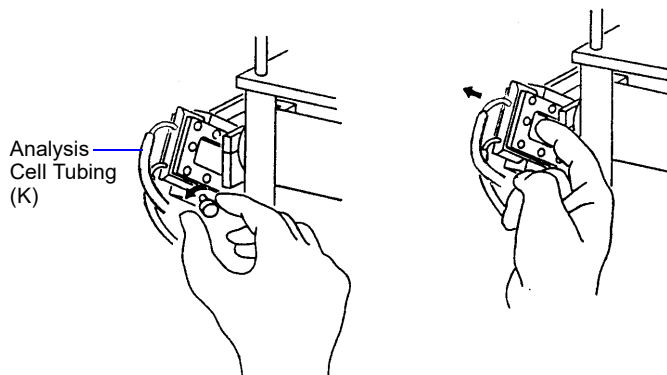

6. Remove the flexible tubing from the two ports on the cell.

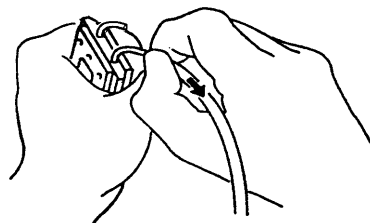

7. Connect the new flexible tubing (labeled K) to the ports on the new analysis cell and to the rigid tubing connector. The tubing for the front port of the cell connects to the front rigid tubing connector and the tubing for the rear port of the cell connects to the rear rigid tubing connector.

8. Insert the cell in the retaining bracket and tighten the cell mounting screw.
9. Close the analysis compartment door.
10. Place the Pump Control switch in the ON position.

Cleaning the Air Filter

The air filter on the analyzer should be cleaned every 30 days (more often in environments with increased levels of dust) and replaced once a year. Refer to **ORDERING INFORMATION**, page **8-1** for the part number of the air filter.

1. Slide out the drip tray on the front of the analyzer.

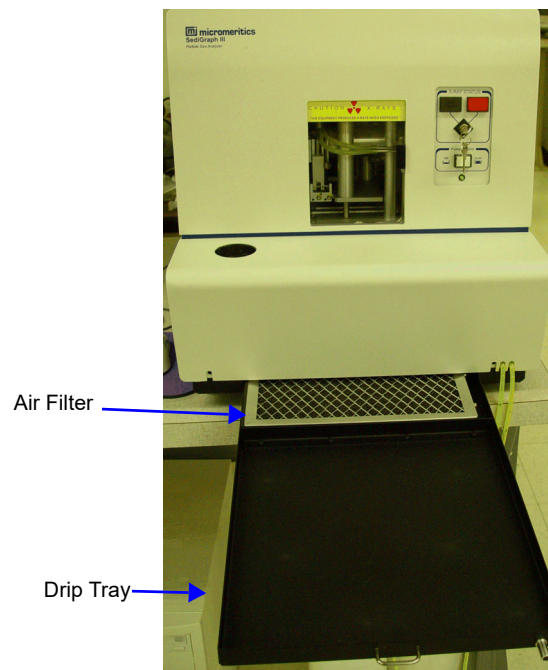

2. Remove the air filter from drip tray by squeezing the filter while pulling it away from the drip tray.
3. Rinse the filter thoroughly and shake out the excess water. Place it aside and allow it to dry.
4. Install a new filter or after the filter has dried, replace it.
5. Check to see that the analyzer is level. Refer to **Checking the Level of the Analyzer**, page **7-18**.

Checking the Operation of the Mixing Pump

The mixing pump should be checked every 30 days (or every 160 runs, whichever comes first) to see if it is operating correctly. To check the operation of the mixing pump:

1. If the instrument schematic is not displayed, select **Show Instrument Schematic**.
2. Go to *Unit [n] > Enable manual control*.
3. Right-click on the **Mixing Pump** symbol, then select **Turn on** from the pop-up menu.

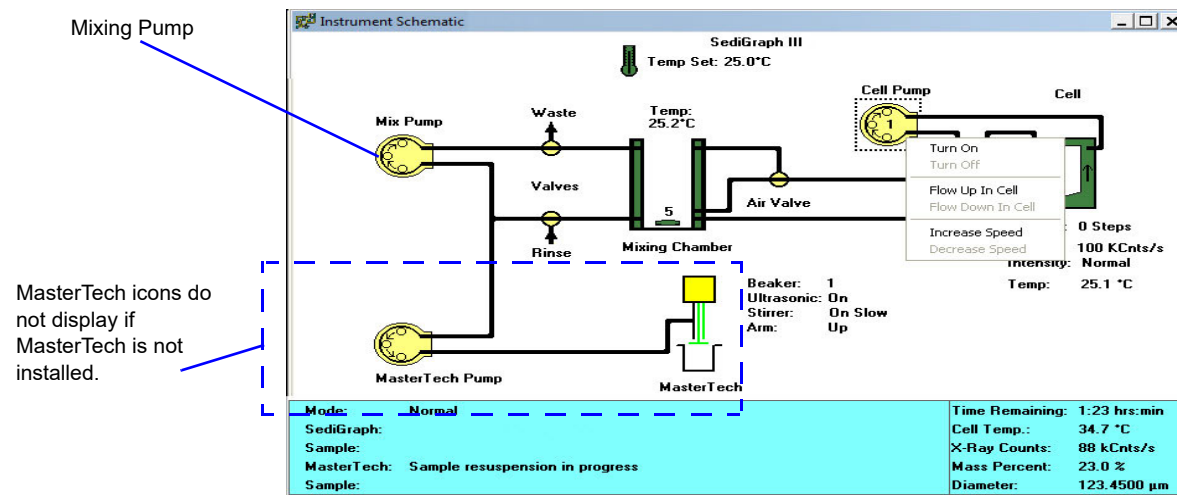

4. If the pump fails to start, refer to the table on [Resetting the Mixing Pump and Cell Pump](#), page [7-23](#) for corrective action.
5. Right-click on the Mixing Pump symbol, then select **Turn off** from the pop-up. If the pump fails to stop, the fluid control board may need replacing; contact your service representative.

Checking the Operation of the Cell Pump

The cell pump should be checked every 30 days (or every 160 runs, whichever comes first) to see if it is operating correctly. To check the operation of the cell pump:

1. If the instrument schematic is not displayed, select **Show Instrument Schematic**.
2. Go to *Unit [n] > Enable manual control*.
3. Right-click on the Cell Pump symbol, then select **Turn on** from the pop-up.

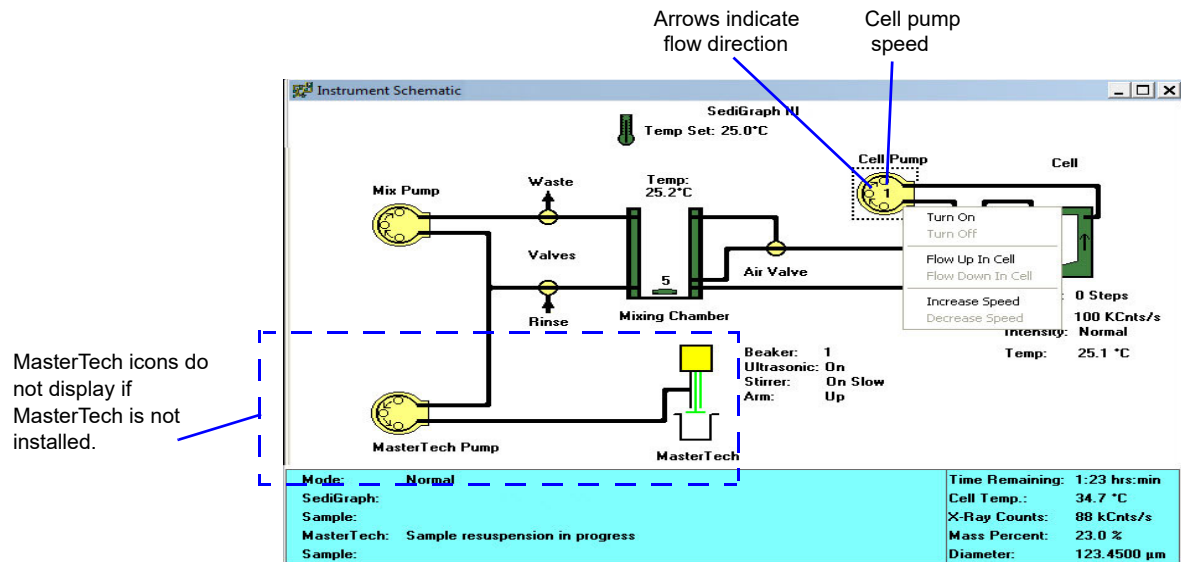

4. Perform the following steps. If any of these steps fail, refer to the table on [Resetting the Mixing Pump and Cell Pump](#), page 7-23 for corrective action.

For each of the following steps, right-click the Cell Pump symbol, then select the item listed:

- Increase speed
 - Decrease speed
 - Flow up in cell
 - Flow down in cell
 - Increase speed
 - Decrease speed
5. Right-click on the Cell Pump symbol, then select **Turn off**. If the pump fails to stop, the fluid control board may need replacing; contact your service representative.

Checking the Level of the Analyzer

An unlevel analyzer may cause inaccurate analyses. Check every 30 days to see if the analyzer is level.

1. Open the analysis compartment door and locate the level indicator.
2. Look straight down at the indicator. The analyzer is level when the bubble is centered inside the black circle on the level indicator.

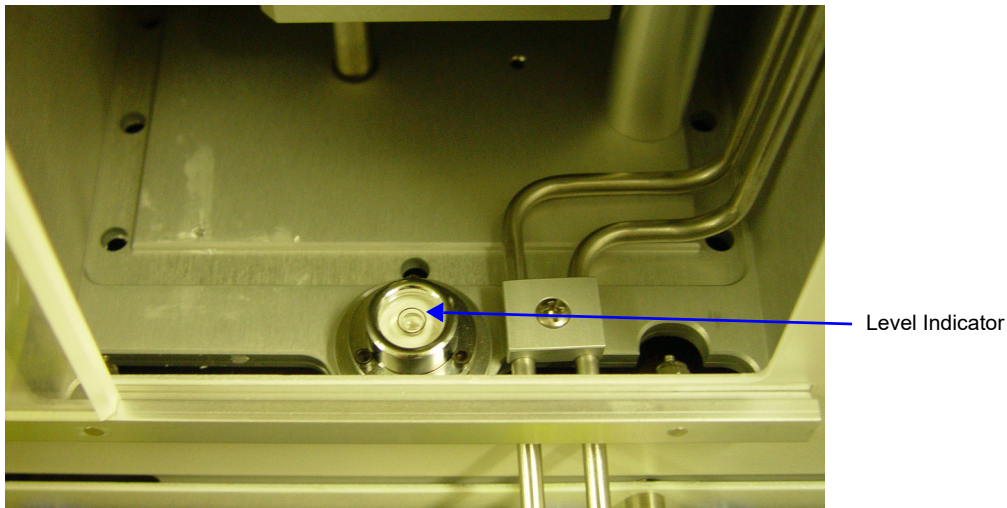

3. If the analyzer is not level, lift the corner then turn the appropriate foot counterclockwise to raise the unit or clockwise to lower the unit.
4. Set the analyzer back down and observe the indicator. The bubble should be centered inside the black circle on the level indicator.

Cleaning the Collimating Slits

The collimating slits may become blocked by dust or debris which accumulates in the analysis compartment over a period of time, causing inaccurate results.

To clean the collimating slits:

1. Place the analyzer ON/OFF switch in the OFF position.
2. Remove the retaining screws from the top of the analyzer; then remove the top panel.
3. Remove the analysis cell. Refer to [Cleaning the Analysis Cell](#), page 7-8 for removal instructions.
4. Remove the two foam plugs in the top of the analysis module.
5. Use a hex driver with an extension to remove the collimator retaining screws.

6. Reach through the door of the analysis compartment to lift the top collimator out of the analysis module.

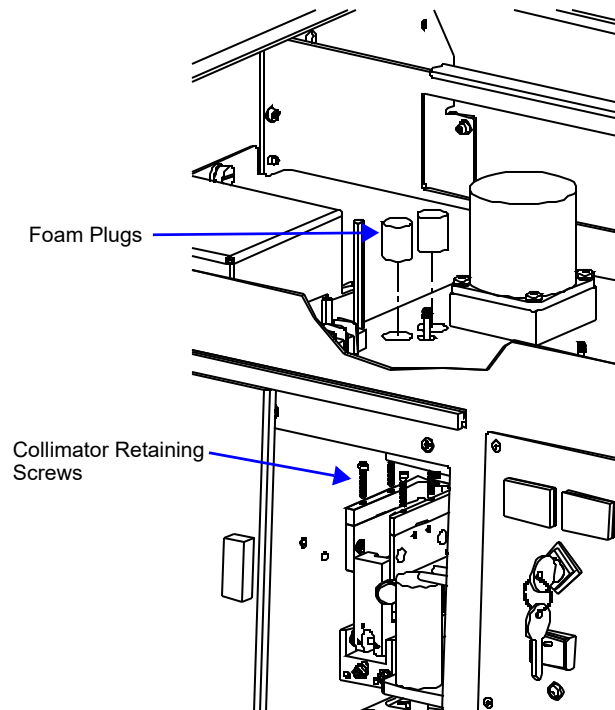

7. Use a lint-free cloth to clean the shiny area near the center of the collimator you have removed and the corresponding area of the collimator remaining in the analysis module.



Do not use cloth made of a coarse material or abrasive cleansers when cleaning the collimating slits.

8. Replace the top collimator and the retaining screws.



Tighten the collimator retaining screws only enough to securely hold the collimator in place. Over-tightening the screws can close the collimating slits, reducing the intensity of (or completely blocking) the X-rays.

9. Tighten the retaining screws for the top collimator.
10. Replace the two foam plugs in the top of the analysis module.
11. Replace the analysis cell and the top panel.
12. Place the analyzer ON/OFF switch in the ON position.

Routine Maintenance

Replacing the X-Ray Indicator Lamps

The X-RAY STANDBY indicator and the X-RAY ON indicator on the front panel of the analyzer contain an internal lamp. If either of these lamps burn out, perform the following steps to replace it.



If the X-RAY ON indicator lamp is burned out or installed incorrectly, the instrument will be inoperative.



Disconnect the analyzer power cord from the AC power source before attempting to replace the lamp. Failure to do so could result in electrical shock or damage to the instrument.

1. Remove the cover lens from the analyzer by prying with a flat object as shown below.

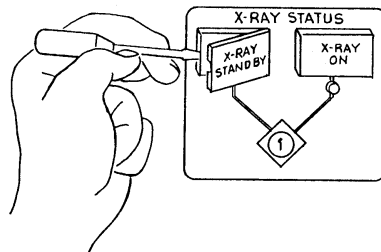

2. Using a flat object, pull the lever which raises the lamp socket out of the lamp compartment as shown below. This makes the lamp accessible.

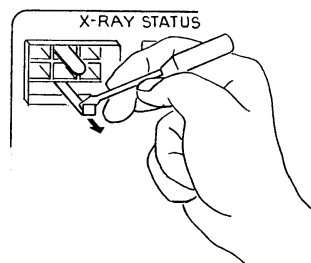

3. Remove the lamp by pulling it away from the socket.

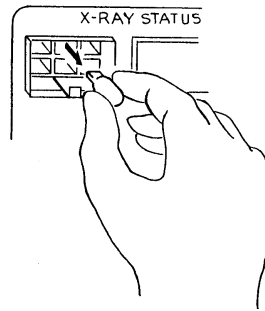

4. Push lamp socket lever toward the analyzer and insert replacement lamp into socket.

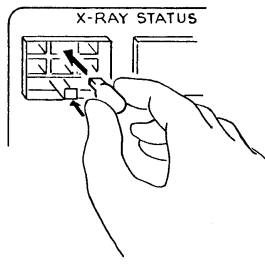

5. Replace the indicator cover lens.
6. Connect the analyzer power cord to an AC power source. Place the ON/OFF switch in the ON position and place the keyswitch in the appropriate position. Verify that the lamp is working.

Replacing the Cell Windows

X-ray photons from the X-ray source pass through the cell windows to the X-ray detector on the other side of the cell. If cell windows become scratched or damaged, settling particles may become entrapped. This could alter X-ray pulses, resulting in invalid analyses. The analysis cell windows should be replaced when necessary. Refer to [Cleaning the Analysis Cell](#), page 7-8.

Replacing the Analysis Cell Assembly

If the analysis cell assembly becomes damaged, it may be necessary to replace it. To replace the analysis cell assembly:

1. Go to *Unit [n] > Drain and Load*.
2. Select **Leave mixing chamber empty**; then **Continue**.
3. When prompted to load the sample, select **Cancel**.
4. Place the Pump Control switch on the analyzer front panel in the OFF position.
5. Open the transparent sliding door to the analysis compartment.
6. Loosen the cell mounting screw and remove the cell from the retaining bracket as shown below.

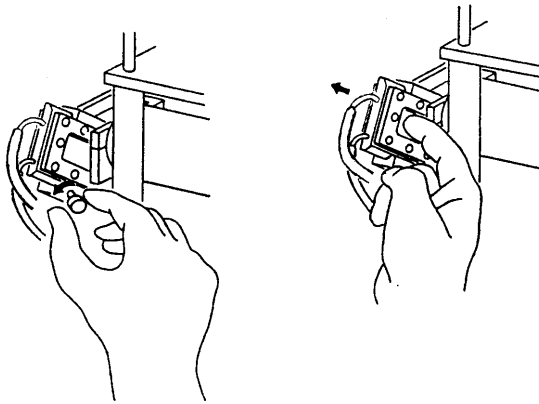

7. Carefully remove the flexible tubing from the two ports on the cell.

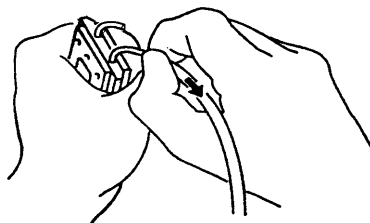

8. Connect the flexible tubing to the ports on the new analysis cell
9. Insert the cell in the retaining bracket and tighten the cell mounting screw.
10. Place the Pump Control switch in the ON position.

Determining the Cause of Bubbles

If bubble problems continue to exist, perform the following steps to determine their source.

1. Install a clean, cell assembly in the cell holder and ensure it is free of bubbles. Refer to **Replacing the Analysis Cell Assembly**, page 7-22.
2. Go to **Unit [n] > Baseline** and perform the steps for collecting baseline data. Refer to **Performing a Baseline Measurement**, page 2-19.

*If the analyzer is successful in obtaining a baseline, the cell proceeds to a parked position, indicating that bubbles are caused by: improper tubing routing, a failed valve, window misalignment, or a loose inlet / outlet port on the cell assembly. Refer to the troubleshooting table at **Troubleshooting**, page 7-1.*

If the analyzer is unable to obtain a baseline, an error message appears in the lower status window. This indicates X-ray detection and / or generation problems may be present. Contact your Micromeritics service representative for corrective action.

Resetting the Mixing Pump and Cell Pump

If an electrical overload occurs with the mixing pump or the cell pump, reset the pumps as follows:

1. Place the Pump Control switch on the front panel in the OFF position.
2. Allow the internal varistor to cool down (approximately two to three minutes).
3. Check the tubing to verify that it is routed properly.
4. Place the Pump Control switch in the AUTO position.
5. Verify pump operation. Refer to **Checking the Operation of the Mixing Pump**, page 7-16 and **Checking the Operation of the Cell Pump**, page 7-17.

Contact your Micromeritics service representative if the problem continues.

Replacing the Ultrasonic Probe Tip

After extended periods of use, the tip of the ultrasonic probe on the MasterTech may become pitted, causing diminished agitation.



Refer to **ORDERING INFORMATION**, page **8-1** to determine the correct part to be used with your probe assembly.

1. Remove the damaged tip from the probe using the wrenches provided.
2. Attach the new probe tip to the probe body. Use the wrenches to tighten securely.



Never hold the probe by the tip. Doing so may cause damage to the probe.

Replacing the MasterTech Input Power Fuse



The power cord should be disconnected from the MasterTech before removing the cover from the power input connector. Failure to disconnect the power cord could result in electrical shock.

1. Ensure the power cord is disconnected from the MasterTech.
2. Using a pointed object, remove the fuse block and cover assembly from the power connector at the rear of the MasterTech.

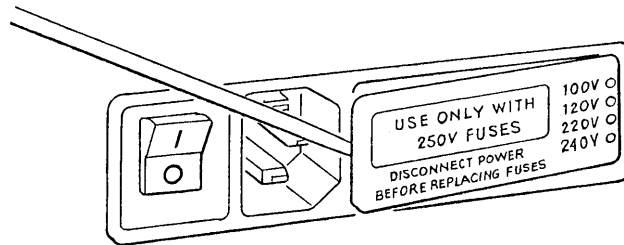

3. Remove the fuse from the fuse block.

The input power connector can be used with either a single-fuse arrangement or a double-fuse arrangement, as shown in the following illustration.

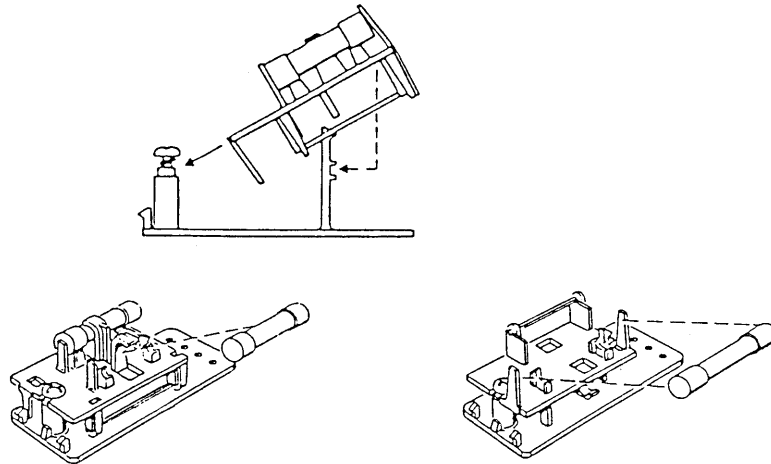

The fuses used in the MasterTech must be identical in type and rating to that specified. Use of other fuses could result in electrical shock and / or damage to the MasterTech.

4. Insert appropriate fuse(s) for the input power source. The following chart gives the appropriate fuse rating.

<u>Power Source</u>	<u>Fuse</u>
100-120 VAC	3AG, 1.25 Amp Slow-Blow
200-240 VAC	5x20 mm, 0.8 Amp Slow-Blow (Type T)

5. Insert fuse block and cover assembly into the input power connector (as shown in the following illustration) and snap it into place.

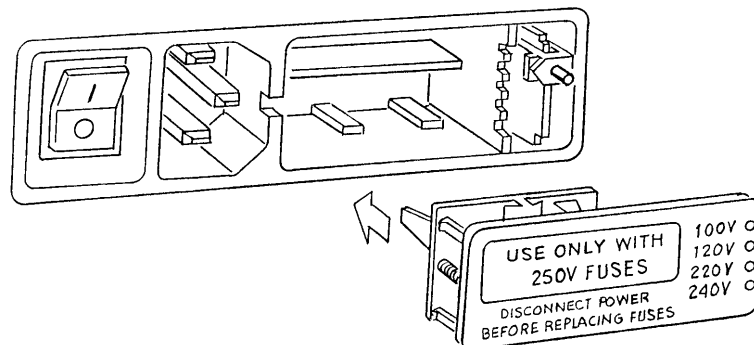

8. ORDERING INFORMATION

The analysis system components and accessories can be ordered using one of the following methods:

- Call our Customer Service Department at (770) 662-3636
- Email orders to orders@micromeritics.com
- Contact your local sales representative

Please use the following information to place an order.

SediGraph Parts and Accessories

Part Number	Item and Description
Analyzer	
512-50000-00	SediGraph III Plus analyzer; includes software, operator's manual, and accessories. This represents either the only analyzer in a single-analyzer system or the first of multiple analyzers in a system.
Cables	
003-20665-00	Interface cable, shielded
003-60101-06	Power cord, shielded
003-63801-01	Cable, Ethernet straight-thru
Filters	
512-27600-01	Filter, air, 10 ppi (washable), for analyzer
512-27600-02	Filter, air, 25 ppi (washable), for analyzer
512-27600-03	Filter, air, 45 ppi (washable), for analyzer
Operating Supplies	
003-39046-00	Lamp for analyzer front panel x-ray status indicators
004-25053-00	Spatula
004-61021-00	Beaker, 100 mL
004-61050-00	Bottle, 10L

Part Number	Item and Description (<i>continued</i>)
004-61050-01	Modified cap for 10L Bottle
500-25610-00	Magnetic stirring bar
500-58904-00	Sound abating enclosure (for use with ultrasonic probe)
510-32801-01	Cell window, set of 2
510-32804-01	Cell window, Homalite®, set of 2
511-25866-00	High settling velocity cell
511-25870-00	Mixing chamber assembly, standard
511-25870-02	Mixing chamber assembly, stainless, for high pH resistance
512-25807-01	Mixing chamber cover bezel
512-33601-00	Recommended operating supplies kit, includes: 2 plastic 10-Liter bottles, 2 magnetic stirring bars, 8 cell windows, 2 analyzer air filters, 5 sets Tygon and 2 sets Silicone tubing.
512-62600-00	Peristaltic pump head, for cell or mixing chamber pump (no motor)
Reference Material	
004-16811-00	Reference material, garnet (~11.0 μm)
004-16814-00	Reference material, glass (~1.5 μm)
004-16835-00	Reference material, fine particle size (~0.77 μm) - Traceable to NIST
004-16837-00	Reference material, garnet (~3.77 μm) - Traceable to NIST
Software and Manuals	
512-20805-00	SediGraph III Plus - operator manual and current version software
512-42805-00	SediGraph III Plus - operator manual

Part Number	Item and Description (<i>continued</i>)
Tubing	
512-32820-01	Tubing set, Tygon®, universal, pre-cut
512-32820-02	Tubing set, universal, pre-cut
512-32820-03	Tubing set, Viton, universal, pre-cut
512-32820-04	Tubing set, Silicone, universal, pre-cut
512-32821-01	Tubing set, Tygon, for mixing chamber pump and cell pump
512-32821-02	Tubing set, universal, for mixing chamber pump and cell pump
512-32821-03	Tubing set, Viton, for mixing chamber pump and cell pump
512-32821-04	Tubing set, Silicone, for mixing chamber pump and cell pump
Ultrasonic Parts	
003-58601-00	Ultrasonic bath, 115 Volts
003-58602-00	Ultrasonic bath, 230 Volts
500-58902-00	Ultrasonic probe, 250 Watts, 115 Volts (not available in countries requiring CE certification)
500-58903-00	Ultrasonic probe, 250 Watts, 230 Volts (not available in countries requiring CE certification)

MasterTech Parts and Accessories

Part Number	Item and Description
004-61021-01	Beaker, tall form, 100mL, glass
051-14811-00	Evaporation cover
051-14814-00	Turntable assembly
051-32901-00	Tubing set, Tygon®, pre-cut
051-58600-06	Ultrasonic probe tip, for use with units that have ultrasonic probe cables with connectors at both ends of the cable. One connects to the top of the probe and the other to the MasterTech.
051-58605-02	Ultrasonic probe tip, for use with units with serial number 151 and greater, which have only one connector that connects to the MasterTech.
052-00000-00	MasterTech 052, for automatic sample preparation. Redisperses samples and transfers them to the SediGraph for analysis. Includes built-in mechanical stirrer and ultrasonic probe.
052-32802-00	Tubing, MasterTech to SediGraph
052-54600-00	Key, Tubing loading

A. ERROR MESSAGES

This chapter contains a numerical listing of the error messages associated with the analysis program. If the Action response for the message instructs you to contact your Micromeritics service representative, record the error message and make backup copies (if appropriate) of any files involved in the operation.

2201- Cannot execute report subsystem.

Cause: Start Report failed to execute the report subsystem (which is a separate process).

Action: Restart the computer. If the problem persists, reinstall the application (this will not affect any of your sample files). Contact your Micromeritics service representative if this message continues.

2401- FATAL ERROR: (error message)

Cause: An internal processing and / or hardware error has occurred.

Action: Contact your Micromeritics service representative if this message continues.

2430- Error accessing file (file name), error code = (number).

Cause A: Diskette may be damaged.

Action A: Clean the diskette drive. If this does not eliminate the problem, attempt the operation using a backup copy of the file.

Cause B: Hard disk may be damaged.

Action B: Contact your Information Technology department or perform hard disk diagnostics.

Cause C: A software error occurred when the file was accessed.

Action C: Contact your Micromeritics service representative.

Cause D: The name specified contains one or more invalid characters.

Action D: Enter a valid file name; do not use characters such as * or ?.

2431- Error writing file (file name), error code = (number).

Cause: The hard disk does not have enough space left to perform the operation.

Action: Copy files not used regularly from the hard disk to diskette, delete them from the hard disk, and then try the operation again.

2432- Invalid response from MMI 'FILE_READ' request.

Cause: An internal processing and / or hardware error has occurred.

Action: Contact your Micromeritics service representative if this message continues.

2433- New entries have been found in this directory. Refresh the directory information?

Cause: Several files have been added to this directory by some function other than the analysis program.

Action: Click **Yes** to update the directory information with data from each new file. This operation may take a minute.

Click **No** to leave the directory information as is. This option may be feasible if a large number of files have been copied into the directory and the name of the file is known.

2434- File (file name) - Subset # (number) wrote wrong amount of data.

Cause: An internal processing and / or hardware error has occurred.

Action: Contact your Micromeritics service representative if this message continues.

2436- Path specification (path name) is invalid.

Cause: An invalid path name and / or extension was entered.

Action: Type a valid path name (including the proper extension) and press **Enter**.

2437- File (file name) does not exist.

Cause: A file specification was entered that does not exist.

Action: Enter an existing file specification or select a file name from the list box.

2438- Disk drive (letter): is inaccessible.

Cause: A disk drive that is not presently accessible was selected

Action: Ensure that the drive is not write-protected.

2439- Cannot register file.**2440- Subset not found.****2441- Seek within file failed.****2442- Bad header in subset file.****2443- Subset owner denied access.****2444- Not a valid file format.****2445- Subset wrote the wrong amount of data.****2446- Error reading data.****2447- Error writing data.**

Cause: An unrecoverable error occurred when accessing a data file.

Action: Contact your Micromeritics service representative.

2448- (directory type) File directory (path name) is invalid. Resetting to the installation directory.

Cause: A working directory specified in the .INI file is invalid. The directory may have been deleted or moved to a different location.

Action: The installation directory will be substituted. The next time a file is opened, use the **Directories:** list to move to the correct directory.

2449- This field does not contain a valid file specification.

Cause: An invalid file name was entered.

Action: Enter a valid file name. A file name can contain up to eight alphanumeric characters.

2450- Sample Defaults may not be edited while this operation is in progress. Do you wish to save and close the Sample Defaults edit session?

Cause: An automatic analysis (an analysis in which sample files are created using the defaults) was initiated while editing the defaults.

Action: Finish the edit session of the defaults and close the window. Then restart the automatic analysis.

2452- Attempt to write MICATTR.DIR in read only mode. (file name)**2453- Attempt to append MICATTR.DIR in read only mode. (file name)**

Cause: The **Read-Only** attribute is turned on in the application's MICATTR.DIR file (this file exists in each folder containing sample or parameter files).

Action: Use Windows Explorer to access the folder containing the MICATTR.DIR file and disable the Read-Only option.

2454- Too many selections for a print-to-file operation. Only the first (number) selections will be processed. Please reselect the remainder.

Cause: A **File > Print** operation was requested on multiple files with the destination specified as a disk file. All of these files cannot be processed in a single operation.

Action: Only the number of files indicated in the message will be processed. When these are complete, return to the **File > Print** menu selection and generate the reports for the remainder.

2455- Too many selections for an export-to-file operation. Only the first (number) selections will be processed. Please reselect the remainder.

Cause: A **File > Export** operation was requested on multiple files with the destination specified as a disk file. All of these files cannot be processed in a single operation.

Action: Only the number of files indicated in the message will be processed. When these are complete, return to the **File > Export** menu selection and generate the reports for the remainder.

2456- Insufficient file handlers available. Application cannot continue.

Cause: The analysis program has attempted to reserve space for the disk files which it will require. This attempt has failed.

Action: Modify the "files=" entry in the CONFIG.SYS file to have a value of 80 or greater. Re-boot the computer and attempt to restart the application. Contact your Micromeritics service representative if this message continues.

2457- Results cannot be displayed. More than (n) windows are currently displaying or printing results.

Cause: A report was sent to the screen or to the printer. This request exceeds the maximum number of reports which may be active at one time.

Action: Close some of the report-to-screen displays currently visible. If reports are active to the printer, wait until they have completed, then repeat the report request.

2458- An instrument is performing a critical operation. Wait a few moments before exiting the application.

Cause: An attempt was made to exit the analysis program while the instrument is performing a critical operation. This operation must be completed before exiting.

Action: Wait a short time and try to exit again.

2459- An instrument is busy. A delay in restarting this application could result in loss of new data. Continue with program Exit?

Cause: An attempt was made to exit the analysis program while an analysis is in progress. While this is possible, the data collected while the analysis program is inactive will not be permanently recorded until the analysis program is re-started. A power failure to the instrument could cause some data to be lost.

Action: Click **Yes** to continue with the exit, however there is a potential for loss of data if a power failure occurs. Click **No** to wait for the analysis to finish.

2460- Fatal Communications error on (Unit n - SN: nnnn)

Cause: There was a fatal error in the serial communications between the analysis program and the analyzer. All displays for that analyzer will be closed.

Action: Ensure that the analyzer is connected to the computer on the communications port configured by the Setup program. Stop and restart the analysis program. If the restarted application cannot establish communications with the analyzer, turn the analyzer off, then back on. Contact your Micromeritics service representative if this message continues.

2461- No instruments are in operation. This application will unconditionally terminate.

Cause: At least one instrument must be active for the analysis program to operate. The initialization of all of the instruments configured with the Setup program has failed.

Action A: Usually this message is preceded by another message giving the reason for the instrument's failure to initialize. Refer to the explanation for that message.

2471- Unit n - SN: nnnn has an invalid communications port specified. It cannot be initialized.

Cause: The communications port associated with this unit was not valid.

Action: Run the setup program and set up the unit on a valid port.

2474- Unit n - SN: nnnn communications port specified in the program control files is already in use. Unit cannot initialize.

Cause: The communications port associated with this instrument is in use by some other program in the system.

Action: Close the other program to release the port. Restart the analysis program.

2475- Unit n - SN: nnnn communications port specified in the program control files cannot be accessed. Unit cannot initialize.

Cause: The communications port associated with this unit was not valid.

Action: Run the Setup program and configure the unit on a valid port.

2476- Unit n - SN: nnnn startup failed. Cannot initialize the communications port.

Cause: The communications port associated with this unit was not valid.

Action: Run the Setup program and configure the unit on a valid port.

2477- Unit n - SN: nnnn did not properly initialize.

Cause A: There were communication problems between the computer and the analyzer.

Action A: Check the communication cables and make sure they are connected securely.

Cause B: **Cancel** was selected during initialization.

Action B: None required.

2478- Error copying sequential data segment.

Cause: An internal processing and / or hardware error occurred while accessing a portion of a sample file.

Action: Confirm that the media being accessed does not contain errors; for example, to use a utility such as ScanDisk. Contact your Micromeritics service representative if this message continues.

2479- Unit n - SN: nnnn The instrument is busy performing an operation of which this application is unaware. Do you want to cancel?

Cause: During initialization, the instrument was found to be analyzing, but the analysis program has no record of it.

Action: Click **Yes** to cancel the analysis and synchronize the analysis program with the instruments status. Click **No** to abort the initialization and allow the analyzer to continue the analysis.

2480- File (file name) cannot be analyzed. It is currently being edited.

Cause: An analysis was attempted using a sample file that is being edited.

Action: Save the changes and close the window.

2481- Error accessing the sample information file (file name) (Code n).

Cause A: An attempt was made to open a file that is already open or minimized.

Action A: View the minimized icons, locate and maximize the file.

Cause B: Diskette may be damaged.

Action B: Clean the diskette drive. If this does not eliminate the problem, attempt operation using a backup copy of the file.

Cause C: Hard disk may be damaged.

Action C: Contact your Information Technology department or perform hard disk diagnostics.

Cause D: A software error occurred when the file was accessed.

Action D: Contact your Micromeritics service representative.

2482- File cannot be opened for writing. It is already in use.

Cause: An attempt was made to open a file that is currently being used (either by this application or another).

Action: Locate the application using the file (in the Micromeritics application, use the Windows menu item to get a list of all windows, one of which may contain this file).

2483- An analysis cannot be performed on (file name). It is open for editing and contains errors.

Cause: An attempt was made to use a sample file containing errors that is currently open.

Action: Go to the window containing the file, correct the errors, and save it.

2484- The edit session for (file name) must be saved before the analysis. Save changes and continue with the analysis?

Cause: An analysis was attempted using a sample file that contains unsaved changes.

Action: Select **Yes** to save the changes and continue with the analysis. Select **No** to abort the analysis and return to the sample file.

2485- The service test file has an invalid status and cannot be used for this analysis.

Cause: The selected service test file has a status other than No Analysis.

Action: Select a different service test file or create a new one and use **Replace All** to copy parameters from the file originally selected.

2486- Cannot construct (name) report type. Program will terminate.**2487- Cannot start report generator. Error code (number). Program will terminate.**

Cause: An internal processing and / or hardware error has occurred.

Action: Contact your Micromeritics service representative if this message continues.

2488- File (file name) cannot be opened for editing. It is already in use.

Cause: The specified file is being used in another edit operation.

Action: Check the Windows list to locate the other edit session.

2489- File (file name) cannot be opened for writing. It is already in use.

Cause: The specified file in a **Save As** operation is already open for edit.

Action: Select a different file for the **Save As** operation.

2490- No '.INI' file present. Application will terminate.

Cause: The ASCII file containing initialization information and system options information used during program startup does not exist.

Action A: Restore the 5125.INI file from a system backup.

Action B: Reinstall the analysis program.

2491- Highlighted fields contain errors. Please correct the errors before closing window.

Cause: The highlighted field(s) contain an invalid entry. Correct the error before closing the window.

Action: Check the entry and correct the error, then close the window.

2492- This field's entry is invalid.

Cause: The highlighted field contains an invalid entry.

Action: Check the entry and correct the error.

2493- An entry is required for this field.

Cause: An invalid entry was used.

Action: Enter or select an appropriate value.

2494- Value is out of the valid range.

Cause: The value entered in the highlighted field is outside the valid range of values.

Action: Check the entry and enter or select an appropriate value.

2495- Value is out of the valid range. Enter a value between (value) and (value).

Cause: The value entered in the highlighted field is outside the valid range of values.

Action: Check the entry and enter or select a value within the indicated range.

2496- Invalid number.

Cause: An invalid number was entered in the highlighted field.

Action: Check the entry and enter or select a valid number.

2497- This field contains an invalid character.

Cause: An invalid number was entered in the highlighted field.

Action: Check the entry and enter valid characters.

2498- The requested change to the Sample's status is invalid at this time.

Cause: A request to change the file's status (for example, from automatically collected to manually entered) could not be done.

Action: Contact your Micromeritics service representative if this message continues. Record the name of the sample file in which the problem occurred.

2499- Sequence number must contain at least 3 digits.

Cause: The sequence number did not contain at least three digits.

Action: Enter a sequence number that contains at least three digits.

2500- All sample file names that can be created using the sequence number pattern already exist. You may want to modify the next sequence number.

Cause: No more sample information files can be created using the currently entered file name sequence number.

Action: Go to **Options > Sample Defaults** and enter a new sequence number.

2501- System resources have reached a dangerously low level. Please close some windows to avoid the loss of data.

Cause: A large number of windows are open and consuming the system resources available to all applications.

Action: Close one or more windows on the screen. Contact your Micromeritics service representative if this message continues.

2502- Error writing to file (name) during print. Error code: (number).

Cause: An error occurred in the file being written to during a print operation.

Action: Ensure that there is sufficient space on the drive containing the file.

2503- Error converting file (file name). Could not create DIO intermediate file.

Cause A: Insufficient space is available on the hard disk. The DIO file is placed in the directory specified by the TEMP environment variable.

Action A: Determine if there is sufficient space on the drive where the TEMP directory is located.

Cause B: An internal processing and / or hardware error has occurred.

Action B: Contact your Micromeritics service representative if this message continues.

2504- Cannot create output file for sample (sample name).

Cause: Insufficient space may be available on the hard disk.

Action: Ensure that sufficient space is available. Contact your Micromeritics service representative if this message continues.

2505- Error Logger cannot be initialized!! Error code (number).

Cause: An internal processing and / or hardware error has occurred.

Action: Contact your Micromeritics service representative.

2506- (sample file) Output device (name) is not installed. Printing cannot be accomplished.

Cause: The selected output device is not installed in Windows.

Action: Select a different output device in the System Configuration window. Install the device using the **Control Panel - Printers** operation.

2508- (sample file) Overlay file (name) was not found. It will not be included in the reports.

Cause: The specified overlay file could not be found.

Action: Ensure that the file specified as an overlay is a valid file.

2509- (sample file) Error opening file (name): (error). Reports cannot be produced.

Cause: An error occurred while the program was opening a file necessary to the report operation.

Action: Use the name given in the error message to investigate. Contact your Micromeritics service representative if this message continues.

2510- (sample file) Error parsing reports from file (name). Reports cannot be produced.

Cause A: One or more data entry fields in the sample file may contain an invalid character (such as a single quote or double quotes).

Action A: Review the data entry fields (for example, the Sample field) and remove the invalid character.

Cause B: The system was unable to create the usual temporary files during the report, possibly due to insufficient disk space.

Action B: Check the space available on the hard disk.

Cause C: An internal processing error occurred.

Action C: Contact your Micromeritics service representative.

2511- Print job (name) has been canceled due to insufficient disk space. Delete unnecessary files and restart the report.

Cause: The disk drive does not have enough space for the temporary file required by the Windows Print Manager. Therefore, printing of the requested report has been canceled.

Action: Delete unnecessary files from the disk. At least 5 megabytes of free space is required for normal operation.

2512- Print job (name) canceled. (number)

Cause: The requested print job was canceled at your request.

Action: None required.

2513- Unable to read the calibration file (file name).

Cause: An invalid calibration file was selected (or one that cannot be read).

Action: Be sure the media containing the alleged calibration file has no problems.

2514- Unable to write the calibration file (file name).

Cause: An attempt to Save calibration data has failed due to possible media problems.

Action A: Be sure the media containing the alleged calibration file has no problems.

Action B: Choose an alternate media to Save the calibration data.

2515- Warning: Changing the calibration information will affect the performance of the instrument. Only qualified service personnel should do this. Do you wish to proceed?

Cause: The process of performing a calibration operation was started.

Action: Calibration operations should only be done by or under the direction of qualified service personnel.

2516- Warning: Keeping a backup copy of the calibration data is recommended by Micromeritics. Would you like to do so now?

Cause: A calibration operation was performed. A backup copy is recommended.

Action: Perform a calibration **Save** operation.

2517- Canceling this window will reset the calibration state to what it was when this window was first opened. Are you sure you want to cancel?

Cause: Accepted the calibration performed.

Action: If the calibration operation was successful, press **Accept**.

2519- Entered or merged data must have at least two points with unique mass percent values.

Cause: The entered and / or merged data included in the report being attempted does not have sufficient unique mass percent values.

Action: Review the entered or merged data. There must be at least two points and the mass percent value of the last point must be different than the mass percent value of the first point.

2521- Unable to program controller.

Cause: A hardware malfunction has occurred.

Action: Contact your local Micromeritics service representative.

2522- Invalid controller application file.

Cause: The application's control file has been corrupted or deleted.

Action: Reinstall the analysis program.

2523- Programming the controller failed.**2524- CRC check failed on programming controller.****2525- Unknown error programming controller.****2526- Controller download was not successful.****2527- Controller CRC error on boot block.****2528- Controller DRAM error.****2529- Controller Com1: error.****2530- Controller Com2: error.****2531- Controller debug port error.**

Cause: An internal processing and / or hardware error has occurred.

Action: Contact your Micromeritics service representative if this message continues.

2532- The instrument contains a different software version. Do you want to reset it?

Cause: The application has discovered a different version of software operating in the analyzer.

Action: If there are no analyzers other than the SediGraph connected to the computer, select **Yes** and allow the updated software to load.

2533- Analyzer initialization failed.

Cause: An internal processing and / or hardware error has occurred.

Action: Contact your Micromeritics service representative if this message continues.

2534- Error opening file (name) for printing. Error code: (number).

Cause: An error occurred in the selected file for print output.

Action: Ensure that sufficient space is available on the drive containing the file.

2549- Error accessing online manual (name).

Cause: An attempt was made to view the online manual but it could not be found.

Action: Reinstall the software. Contact your Micromeritics service representative if this message continues.

4200- An error occurred while loading the application control information. Data entry cannot be performed. (Code # <n>)

Cause: An internal error occurred while read control information was being read from a disk file.

Action: The disk on which the application is installed may have failed. Contact your Micromeritics service representative and report the code number given in the message.

4201- No reports selected.

Cause: No reports were selected in the **Reports to Generate** list box. No output could be produced.

Action: Ensure that at least one report is selected for the sample and re-submit the sample for reporting.

4202- No valid data to report.

Cause: The selected analysis in the sample file activated for reporting does not contain any valid data.

Action: If the sample is still analyzing, wait until enough data have been collected to allow reporting. If the sample is complete, an error or operator intervention stopped this analysis before sufficient data could be collected. The analysis may be deleted from the file.

4203- The reference file is not valid. 'Diff. from ref.' column was deleted.

Cause: A tabular report was requested with *Difference from reference* selected as one of the columns. This quantity cannot be computed because the reference file is invalid.

Action: If no reference file has been specified, select one from the Report Options window and re-run the reports. If a file has been specified, ensure that it contains valid information.

4204- Coarser specification file is not valid. 'Out of spec.' column was deleted.

Cause: A tabular report was requested with **Out of Specification** selected as one of the columns. This quantity cannot be computed because the coarse specification file is invalid.

Action: If no specification file has been specified, select one from the Report Options window and re-run the reports. If a file has been specified, ensure that it contains valid information.

4205- Finer specification file is not valid. 'Out of spec.' column was deleted.

Cause: A tabular report was requested with the **Out of Specification** selected as one of the columns. This quantity cannot be computed because the finer specification file is invalid.

Action: If no specification file has been specified, select one from the Report Options window and re-run the reports. If a file has been specified, ensure that it contains valid information.

4206- The tabular report has no valid columns selected. No report produced.

Cause: A tabular report was requested with all of the columns set to *none*.

Action: Edit the options for that table and select a variable in at least one column of the table.

4207- No valid data is available for this report. No report produced.

Cause: The selected test in the sample file activated for reporting does not contain any valid data.

Action: If the sample is still analyzing, wait until enough data have been collected to allow reporting. If the sample is complete, an error or operator intervention stopped this analysis before sufficient data could be collected. The analysis may be deleted from the file.

4208- An overlay file is not valid. It was not included in the report.

Cause: The sample file selected for overlay does not exist or contains invalid data.

Action: From the Report Options window, click **Overlays** and remove the sample file.

4209- The reference file is not valid. The report was not produced.

Cause: The **Difference from Reference** graph was selected. It cannot be computed because the reference file is invalid.

Action: If a reference file has not been specified, select one from the Report Options window and re-run the reports. If a file has been specified, ensure that it contains valid information.

4210- Coarser specification file is not valid. The report was not produced.

Cause: The **Out of Specification** graph was selected. It cannot be computed because the coarse specification file is invalid.

Action: If a specification file has not been specified, select one from the Report Options window and re-run the reports. If a file has been specified, ensure that it contains valid information.

4211- Finer specification file is not valid. The report was not produced.

Cause: The **Out of Specification** graph was selected. It cannot be computed because the fine specification file is invalid.

Action: If a specification file has not been specified, select one from the Report Options window and re-run the reports. If a file has been specified, ensure that it contains valid information.

4212- At least one report item must be selected. Press Cancel if you do not want a report.

Cause: No reports were selected in the **Reports to Generate** list box. No output could be produced.

Action: Ensure that at least one report is selected for the sample and re-submit the sample for reporting.

4213- Are you sure you want to delete the test?

Cause: **Delete** was selected on the **Collected Data** editor.

Action: Click **Yes** to remove the indicated test from the sample file. Click **No** to have the test remain in the sample file.

6001- An automatic analysis mode is enabled. The sample defaults may not be edited while this mode is active.

Cause: One of the automatic analysis modes is active. Sample defaults may not be edited while this mode is active.

Action: End all automatic analysis modes on all attached units and try again.

6002- Error accessing the sample information file (file name). (Code <n>).

Cause A: Full rights to the application's folders and files is required.

Action A: Contact your system administrator to have full rights granted.

Cause B: An error occurred when trying to access a sample file.

Action B: Report the error code number given in the message to your Micromeritics service representative.

6003- File (file name) already has all its tests filled.

Cause: An attempt was made to insert a new test into a sample which already contains eight tests.

Action: A single sample file can have a maximum of eight tests. If additional tests are required on this sample, create another sample file.

6004- File `(file name)` cannot be analyzed. It is currently being edited.

Cause: A file was selected which was still open in an editing window for analysis.

Action: Finish the changes to the sample file, then save and close the editing window.

6005- The file (file name) can not be prepared for analysis. It is open for editing and contains errors.

Cause: A file was selected which is currently being edited. Editing cannot be finished because the sample contains entry fields with errors.

Action: Correct the errors and finish editing the sample file. Then save, close the editing window, and try opening the file again.

6006- The edit session for `(file name)` must be saved before it is prepared for analysis. Save changes and proceed with the analysis?

Cause: A file was selected for analysis which is currently being edited. The changes to this file must be saved before it can be prepared for analysis.

Action: Click **Yes** to save the changes and proceed with the analysis. Click **No** to review the changes before saving them.

6007- (Unit n - SN: nnnn) Bubble elimination failed. Operation cancelled.

Cause A: A wetting agent may be required to aid in bubble elimination.

Action A: Add one drop of Photo-Flo 200 or other wetting agent to the mixing chamber.

Cause B: Cold suspension fluid was introduced to the heated mixing chamber and cell, causing the release of dissolved gases.

Action B: Warm the suspension fluid prior to introduction, or allow it to circulate in the mixing chamber for several minutes before starting the analysis.

Cause C: Dispersion indicated in cell is not uniform.

Action C: Wait to see if bubbles are eliminated. Then check tubing for clogs or damage. Replace tubing if necessary.

Cause D: The sample material being analyzed requires more suspension energy.

Action D: Change the analysis options to increase the pump speed specified for the full-scale scan operation. After changing the sample file, repeat the analysis.

Cause E: The sample material being analyzed has a high density.

Action E: Change analysis options to reduce the sensitivity of the bubble detection method. After changing the sample file, repeat the analysis.

6008- (Unit n - SN: nnnn): Bubble elimination difficulties encountered.

- Cause A:* A wetting agent may be required to aid in bubble elimination.
- Action A:* Add one drop of Photo-Flo 200 or other wetting agent to the mixing chamber.
- Cause B:* Cold suspension fluid was introduced to the heated mixing chamber and cell, causing release of dissolved gases.
- Action B:* Warm the suspension fluid prior to introduction, or allow it to circulate in the mixing chamber for several minutes before starting analysis.
- Cause C:* Dispersion indicated in cell is not uniform.
- Action C:* Wait to see if bubbles are eliminated. Then check tubing for clogs or damage. Replace tubing if necessary.
- Cause D:* Material under analysis requires more suspension energy.
- Action D:* Change the cell pump speed in your analysis options, then repeat the analysis.
- Cause E:* Material under analysis has high density.
- Action E:* Change the bubble detection method to *medium* or *coarse* in your analysis options, then repeat the analysis.

6009- (Unit n - SN: nnnn) Failure reestablishing full scale concentration. Analysis will continue.

- Cause A:* The system could not reach the same level of sample suspension as during the previous full-scale scan.
- Action A:* Cancel the current analysis. Use manual control to change the cell pump speed to 5 and operate the pump for one or two minutes. Repeat the analysis.
- Cause B:* Sample residue is trapped in the system.
- Action B:* Check the tubing and fittings for clogs and residue. Squeeze the tubing at all locations where residue is trapped. Repeat the analysis.

6010- (Unit n - SN: nnnn) Sample concentration is low. Analysis will continue.

Cause A: Too little sample was used, causing a 13% change in X-ray adsorption.

Action A: Cancel the current analysis. Using manual control, turn on both pumps and add more dispersed sample to the mixing chamber. Restart the analysis.

Cause B: The sample requires more suspension energy.

Action B: Cancel the current analysis. Using manual control, operate the cell pump in the UP direction at pump speed 5 for one or two minutes. Restart the analysis.

6011- (Unit n - SN: nnnn) Sample concentration is high. Analysis will continue.

Cause: Too much sample was used, causing more than a 75% change in X-ray absorption.

Action: Cancel the current analysis. Using manual control, turn on both pumps and add more dispersing liquid to the mixing chamber to dilute the sample mixture. Restart the analysis.

6012- (Unit n - SN: nnnn) No x-rays detected.

Cause A: The solid portion of the cell is blocking the X-rays from the detector.

Action A: Using manual control, move the cell to a different position.

Cause B: The slit in the X-ray source or detector is blocked.

Action B: Clean the slits in the X-ray source to remove any residue. Refer to [Cleaning the Collimating Slits](#), page 7-18.

6013- (Unit n - SN: nnnn) No x-rays detected due to key at Standby.**6014- (Unit n - SN: nnnn) No x-rays detected due to door open.****6015- (Unit n - SN: nnnn) No x-rays detected due to panel off.****6016- (Unit n - SN: nnnn) No x-rays detected due to X-Ray filament over-current.****6017- (Unit n - SN: nnnn) No x-rays detected due to X-Ray lamp off.**

Cause: No x-rays are detected due to the problem described in the error message.

Action: Correct the problem, then restart the operation.

6018- (Unit n - SN: nnnn) No x-rays detected. Automatic operation will cancel.

Cause A: The solid portion of the cell is blocking the X-rays from the detector.

Action A: Using manual control, move the cell to a different position.

Cause B: The slit in the X-ray source or detector is blocked.

Action B: Clean the slits in the X-ray source to remove any residue. Refer to [Cleaning the Collimating Slits](#), page 7-18.

6019- (Unit n - SN: nnnn) No x-rays detected due to key at Standby. Automatic operation will cancel.**6020- (Unit n - SN: nnnn) No x-rays detected due to door open. Automatic operation will cancel.****6021- (Unit n - SN: nnnn) No x-rays detected due to panel off. Automatic operation will cancel.****6022- (Unit n - SN: nnnn) No x-rays detected due to X-Ray filament over-current. Automatic operation will cancel.****6023- (Unit n - SN: nnnn) No x-rays detected due to X-Ray lamp off. Automatic operation will cancel.**

Cause: No x-rays are detected due to the problem described in the error message. The automatic operation that is in progress will be canceled.

Action: Correct the problem, then restart the operation.

6024- (Unit n - SN: nnnn) Error rinsing system. Cannot reestablish baseline concentration.

Cause A: The dispersing liquid being used is different from the one used for measuring the baseline.

Action A: Perform a baseline measurement using the current dispersing liquid.

Cause B: Sample residue has remained in the cell.

Action B: Cancel the current operation. Using manual control, select the **Flow Up in Cell** direction for the cell pump at pump speed 5 for one or two minutes. Also check for clogs in the tubing and crimped tubing as necessary. Visually inspect the cell windows, clean or replace as necessary. Refer to [Preventive Maintenance](#), page 7-5.

6025- (Unit n - SN: nnnn) Cannot find beamsplit.

Cause A: The cell has been removed from the analyzer.

Action A: Replace the cell and resume operation.

Cause B: The cell elevator is not operating properly.

Action B: Contact your Micromeritics service representative.

6026- (Unit n - SN: nnnn) Cannot find beamsplit. Automatic operation will cancel.

Cause A: The cell has been removed from the analyzer.

Action A: Replace the cell and resume the operation.

Cause B: The cell elevator is operating improperly.

Action B: Contact your Micromeritics service representative.

6027- (Unit n - SN: nnnn) Not enough cell travel to perform an analysis.

Cause A: Cell assembly is assembled improperly.

Action A: Disassemble the cell assembly and reassemble. Be sure the sloped portions of the cell body and the retaining plates are aligned. Refer to [Cleaning the Analysis Cell](#), page 7-8.

Cause B: The upper limit switch of the cell elevator must be reset.

Action B: Contact your Micromeritics service representative.

6028- (Unit n - SN: nnnn) Not enough cell travel. Automatic operation will cancel.

Cause A: Cell assembly is assembled improperly.

Action A: Disassemble the cell assembly and reassemble. Be sure the sloped portions of the cell body and the retaining plates are aligned. Refer to [Cleaning the Analysis Cell](#), page 7-8.

Cause B: The upper limit switch of the cell elevator must be reset.

Action B: Contact your Micromeritics service representative.

6029- (Unit n - SN: nnnn) Upper limit switch not found.

- Cause A:* The cell position counter is too far out of position to find the upper limit switch. The lower limit switch may have been triggered.
- Action A:* Using manual control, move the cell to the upper limit switch; this resets the cell position counter.
- Cause B:* The cell elevator is not operating properly.
- Action B:* Contact your Micromeritics service representative.
- Cause C:* The upper limit switch is operating improperly.
- Action C:* Contact your Micromeritics service representative.

6030- (Unit n - SN: nnnn) Error moving cell.

- Cause A:* Some object or the cell tubing is preventing the cell elevator from moving.
- Action A:* Check for and remove object, or reposition the cell tubing.
- Cause B:* The cell elevator is operating improperly.
- Action B:* Contact your Micromeritics service representative.

6031- (Unit n - SN: nnnn) Error moving cell. Automatic operation will cancel.

- Cause A:* Some object or the cell tubing is preventing the cell elevator from moving.
- Action A:* Check for and remove any foreign object, or reposition the cell tubing.
- Cause B:* The cell elevator is operating improperly.
- Action B:* Contact your Micromeritics service representative.

6032- (Unit n - SN: nnnn) Temperature is not within the range of the liquid properties set.

- Cause:* The temperature of the analysis compartment at the time of the analysis is not within the range defined by the liquid properties specified in the sample file.
- Action:* Go to **Unit [n] Unit Configuration** and either change the analysis compartment temperature, then clicking the **Set Temperature** button or change the liquid properties in the associated sample file.

6033- (Unit n - SN: nnnn) Liquid density must be less than sample density.

Cause: The density of the dispersing liquid is too high for the sample being analyzed.

Action: Switch the dispersing liquid to one with density lower than that of the sample.

6034- (Unit n - SN: nnnn) Fan problem (code n,n)

Cause: One or both of the cooling fans are operating at less than 70% of the normal speed. The code values are: 1,0 means the PMT fan has the problem; 0,1 means the X-ray fan has the problem; 1,1 means both fans have the problem. The third fan (located under the tube's anode) will need to be checked visually. The third fan (located under the tube's anode) will need to be checked visually. To access to the fan, remove the analyzer cover then remove the shield.

Action: Turn off the analyzer. Contact your Micromeritics service representative.

6035- (Unit n - SN: nnnn) Electronics problem.

Cause: An electronic component is not operating to specification.

Action: Turn off the analyzer. Contact your Micromeritics service representative.

6036- (Unit n - SN: nnnn) Using mixing chamber speed of (n) which differs from requested speed of (n). Analysis will continue.

Cause: The mixing chamber speed specified in the sample file being analyzed (*requested* speed) is not the same as the speed at which the mixing chamber is currently operating.

Action: No action required unless the mixing chamber speed needs to be adjusted. In this case, enable manual control and adjust the speed.

6037- (Unit n - SN: nnnn) Fan problem (code n,n). Automatic operation will cancel.

Cause: One or both of the cooling fans are operating at less than 70% of the normal speed. The code values are: 1,0 means the PMT fan has the problem; 0,1 means the X-ray fan has the problem; 1,1 means both fans have the problem. The third fan (located under the tube's anode) will need to be checked visually. To access to the fan, remove the analyzer cover then remove the shield.

Action: Turn off the analyzer. Contact your Micromeritics service representative.

6038- (Unit n - SN: nnnn) Electronics problem. Automatic operation will cancel.

Cause: An electronic component is not operating to specification.

Action: Turn off the analyzer. Contact your Micromeritics service representative.

6039- (Unit n - SN: nnnn) Error moving turntable.

Cause: The arm is in the Load position or something is preventing the beaker tray from moving.

Action: Make sure the arm is not in the Load position or that nothing is preventing the beaker tray from moving.

6040- (Unit n - SN: nnnn) Error moving turntable. MasterTech automatic operation will cancel.

Cause: The arm is in the Load position or something is preventing the beaker tray from moving.

Action: Make sure the arm is not in the Load position or that nothing is preventing the beaker tray from moving.

6041- (Unit n - SN: nnnn) Error moving arm assembly.

Cause: The arm is in the Load position or something is preventing the arm from moving.

Action: Make sure the arm is not in the Load position or that nothing is preventing the arm from moving.

6042- (Unit n - SN: nnnn) Error moving arm assembly. MasterTech automatic operation will cancel.

Cause: The arm is in the Load position or something is preventing the arm from moving.

Action: Make sure that the arm is not in the load position or that nothing is preventing the arm from moving.

6043- (Unit n - SN: nnnn) Not present.

Cause A: The MasterTech has been turned off.

Action A: Check the power connection and make sure the POWER ON/OFF switch on the MasterTech is in the ON (1) position.

Cause B: The MasterTech is not properly connected to the analyzer.

Action B: Check the control cable from the MasterTech to ensure that it is properly connected.

6044- (Unit n - SN: nnnn) Turntable not present.

Cause: The turntable is not properly installed on the MasterTech.

Action: Install the turntable as described in the Installation Manual.

6045- (Unit n - SN: nnnn) Turntable not present. MasterTech automatic operation will cancel.

Cause: The turntable is not properly installed on the MasterTech.

Action: Install the turntable as described in Installation Manual.

6046- (Unit n - SN: nnnn) Arm assembly at the load position.

Cause: An attempt was made to perform an operation that is inoperable when the arm is in the Load position.

Action: Press the front panel switch to take the arm out of the Load position.

6047- (Unit n - SN: nnnn) Arm assembly at the load position. MasterTech automatic operation will cancel.

Cause: An attempt was made to perform an operation that is inoperable when the arm is in the Load position.

Action: Press the front panel switch to take the arm out of the Load position.

6048- (Unit n - SN: nnnn) Cannot find position 1 on the turntable.

Cause: The turntable may not be seated properly. If the turntable is moving properly, a service problem may be indicated.

Action: Contact your Micromeritics service representative.

6049- (Unit n - SN: nnnn) No beaker is present in position (n).

Cause: An action was requested, such as a MasterTech rinse, but there is no beaker present in the specified position.

Action: Insert a beaker at the specified position and restart the operation.

6050- (Unit n - SN: nnnn) No beaker is present in position (n). MasterTech automatic operation will cancel.

Cause: An action was requested, such as a MasterTech rinse, but there is no beaker present in the specified position.

Action: Insert a beaker at the specified position and restart the operation.

6051- Conversion has not finished, close anyway?

Cause: An attempt was made to close the conversion status window before the conversion of all files was complete.

Action: Click **Yes** to cancel the conversion. Click **No** to allow conversion of all files to finish.

6052- Cannot read source file (file name).

Cause: An attempt was made to convert a non-Windows sample file, but the file could not be read from the disk drive.

Action: The conversion of other files will continue; however, the specified file may be invalid. If this error occurs on multiple files, the disk drive containing the files may have failed.

6053- Destination file (file name) already exists.

Cause: An attempt was made to convert a sample file with the same name as an existing file.

Action: Delete the original destination file and repeat the conversion operation.

6054- Unable to create destination file (file name).

Cause: An attempt was made to convert a non-Windows file, but the output file cannot be created.

Action: The disk on which the converted file is to be stored may be full or may have failed.

6055- Unable to load the Liquid Properties for file (file name). Defaults will be used.

Cause: An attempt was made to convert a non-Windows file, but the liquid properties could not be located.

Action: The conversion will continue using the default liquid properties. The converted data will be valid and usable. To conduct the conversion without warnings, ensure that the specified file is located in the 'System Directory' specified on the File Conversion window and repeat the conversion.

6056- Unable to load the Particle Size table for file (file name). Defaults will be used.

Cause: An attempt was made to convert a non-Windows file, but the user-defined report table could not be located.

Action: The conversion will continue using the defaults report table. The converted data will be valid and usable. To conduct the conversion without warnings, ensure that the specified file is located in the 'System Directory' specified on the File Conversion window and repeat the conversion.

6057- Conversion aborted. Unrecoverable error converting (file name) into (file name).

Cause: An error occurred when converting a non-Windows file to the Windows format.

Action: The file cannot be converted. Contact your Micromeritics service representative.

6058- At least one item must be selected for recording.

Cause: The Start Recording Service Test step requires that at least one signal be selected for recording.

Action: Select a signal or click **Cancel**.

6059- An incompatible table with that name already exists.

Cause: In a Service Test script, data collected have names, each of which must be unique.

Action: Specify a different name for the data.

6060- Unable to read the calibration file (file name).

Cause: The calibration file selected for loading is not valid or cannot be read.

Action: Confirm the media containing the alleged calibration file has no problems.

6061- Unable to write the calibration file (file name).

Cause: An attempt to Save calibration data has failed due to possible media problems

Action A: Confirm the media containing the alleged calibration file has no problems.

Action B: Choose an alternate media to Save the calibration data.

6062- The instrument (unit number) is not calibrated.

Cause: Calibration information for various analyzer components are missing.

Action: Run the application setup program and reinstall calibration information for the specified unit.

6063- File cannot be opened for writing. It is already in use.

Cause: A **File Save As** operation failed because the specified file is already in use.

Action: Specify a different file.

6064- The sample file [name] is not in a valid state to resume the analysis.

Cause: The status of the sample file has changed since last used. It can no longer be used as part of an analysis.

Action: Select a new sample file, and restart the analysis.

6065- You need to choose a sample file.

Cause: **OK** was selected on a schedule entry window, but a sample file was not selected.

Action: Click **Browse** and select a sample file.

6066- There is no more room for another test in this sample.

Cause: A sample file was selected for analysis that already contains eight tests.

Action: Select a different sample file, or delete one of the previous tests from the file.

6067- The current baseline does not match the one already in the sample.

Cause: A sample file was selected that contains some analyses that were performed using a different baseline.

Action: Select a sample file that either has no tests, or has tests that were performed using the current baseline.

6068- The previous tests of this sample were run on a different SediGraph.

Cause: A sample file was selected that contains some analyses that were performed using a different analyzer.

Action: Either perform the new analysis on the same analyzer, or select a different sample file.

6069- The sample has an invalid status and cannot be used for this analysis.

Cause: A sample file was selected that cannot be analyzed.

Action: Select a file that has a status of *No Analysis* or *Complete*.

6070- Unit n - SN: nnnn There is no baseline available for this unit.

Cause: No baseline has been measured for this unit.

Action: Measure a baseline before performing sample analyses.

6071- Configured serial number does not match instrument.

Cause: The serial number stored in the analyzer does not match the serial number stored with the software.

Action: Contact your Micromeritics service representative.

6072- Could not update the Liquid Properties file (file name). It is currently in use.

Cause: **Change** was selected on the **Material Properties** window to change a liquid properties set. The selected properties cannot be updated because it is being edited.

Action: Close the editing session for the named **Liquid Properties** and try again.

6073- Could not create the new Liquid Properties file (file name). Properties were not saved.

Cause: **Add** was selected for a liquid properties set on the **Material Properties** window. The new properties set cannot be created.

Action: The disk drive on which the liquid properties are stored may be full or may have malfunctioned.

6074- Could not delete the Liquid Properties file (file name). It is currently in use.

Cause: **Delete** was selected for a liquid properties set on the **Material Properties** window. The selected properties set cannot be deleted because it is being edited.

Action: Close the editing window and try again.

6075- New data reduction options are currently being applied to the test data. Do you wish to cancel the reprocessing?

Cause: An attempt was made to change the material properties for a completed sample. These changes are currently being applied to all of the data collected for that sample.

Action: Click **Yes** to cancel the changes. Click **No** and the computation will continue.

6076- Application of new data reduction options to (file name) is complete.

Cause: A request was made for a change to the material properties on a completed sample file. These changes have been applied to all of the data collected for the sample.

Action: Click **OK** to acknowledge the message. Click **Save** if the results are as expected.

6077- All of the test data will be converted to the new data reduction options. Do you wish to continue?

Cause: A change was requested to the material properties for a completed sample file. These changes are about to be applied to all of the data collected for that sample.

Action: Click **No** to cancel the changes. Click **Yes** and the computation will continue.

6078- The current hardware does not match the calibration.

Cause: One or more calibrated components have been replaced in the analyzer.

Action: Contact your Micromeritics service representative.

6079- The Schedule contains duplicate beaker entries. Are you sure you want to continue?

Cause: **Start** was selected on the MasterTech Schedule window and there is more than one entry in the schedule that has the same beaker number.

Action: Click **No** to stop the operation and fix the schedule. Click **Yes** to continue with the schedule.

6080- Cell nominal temperature value not in the expected range of (nnn.nn).

Cause: During temperature calibration, the value read is outside of the expected range.

Action: Confirm that the correct temperature calibration resistor is being used.

6081- Error computing particle sizes! The baseline or the fullscale was zero.

Cause: Due to insufficient or inadequate analysis results, an error occurred while converting the raw data collected by the instrument into a particle size distribution.

Action A: The data from this analysis cannot be used. The analysis may be deleted from the sample file.

6082- Mixing chamber nominal temperature value not in the expected range of (n) to (n).

Cause: During temperature calibration, the value read is outside of the expected range.

Action: Confirm that the correct temperature calibration resistor is being used.

6083 (Data Reduction) Zero denominator in mass computation.

Cause: Due to insufficient or inadequate analysis results, an error occurred while converting the raw data collected by the instrument into a particle size distribution.

Action: The data from this analysis cannot be used. The analysis may be deleted from the sample file.

6084- (Data Reduction) Less than 11 data points collected.

Cause: Due to insufficient or inadequate analysis results, an error occurred while converting the raw data collected by the instrument into a particle size distribution.

Action: The data from this analysis cannot be used. The analysis may be deleted from the sample file.

6085- (Data Reduction) Computed a particle size of zero.

Cause: The material properties specified for this sample result in a particle size computation which is less than or equal to zero.

Action: The data from this analysis will not be converted into a particle size distribution. Edit the material properties for the sample and modify them so they are valid. Click **Update Properties** on the Material Properties window to reprocess the analysis results.

6086- (Data Reduction) Insufficient data for mass filter.

Cause: Due to insufficient or inadequate analysis results, an error occurred while converting the raw data collected by the instrument into a particle size distribution.

Action: The data from this analysis cannot be used. The analysis may be deleted from the sample file.

6087- The Coarse / Fine specification file is invalid. No results available.

Cause: A request was made for an invalid file either the coarse or fine specification.

Action: If no specification files have been specified, select them from the Report Options window and re-run the report. If files have been specified, ensure that they contain valid data.

6088- The cell temperature reading of (nnn.nn) is invalid. If an analysis is in progress you may choose to cancel it.

Cause: A temperature reading outside of the valid range has occurred.

Action: If the problem persists, contact your Micromeritics service representative.

6089- The mixing chamber temperature reading of (nnn.nn) is invalid. If an analysis is in progress you may choose to cancel it.

Cause: A temperature reading outside of the valid range has occurred.

Action: Contact your Micromeritics service representative if this message continues.

6090- The sample is already scheduled to be used for another analysis.

Cause: A sample file was requested for an analysis that is already scheduled in the MasterTech schedule or the Repeat schedule.

Action A: Select a different sample that is not scheduled in the MasterTech schedule or the Repeat schedule.

Action B: Remove the sample from where it is already scheduled and then try again.

B. SAMPLE DISPERSION

Use of the SediGraph requires that each powder be well dispersed in a liquid of known density and viscosity and that the difference between the powder and liquid densities be accurately known. Viscosity and density data for some common liquids are given in Appendix G. Handbook values for other liquids are usually sufficiently accurate, so the latter requirement means that only the powder density must be determined if it is unknown and if composition information does not permit calculation from handbook values. For this, one of Micromeritics' pycnometers is recommended. For materials likely to have dead-end pores into which liquid may not completely penetrate, the effective density* may need to be determined using the sedimentation liquid to be employed and a gas pycnometer.

The liquid should be one in which the powder can be completely dispersed (separated into unattached particles) for accurate size results to be obtained. Obviously, the liquid should be nontoxic, readily available, and one in which the sample is insoluble. Complete insolubility may be difficult to achieve in some instances. Solubility problems may be minimized by allowing the liquid to stand in contact with the particle material prior to using the liquid for the test sample. This cannot completely eliminate problems, however, because particle solubility is a function of particle size. Small particles are more soluble than large ones; in a dispersion of different sizes, the smallest particles tend to go into solution while precipitation occurs on the larger particles. In making a particle size distribution analysis, particle solubility is indicated if the recorded distribution consistently fails to attain zero percent even long after the analysis is complete.

There are no established rules or laws by which complete particle dispersion can be assured. Only guidelines can be offered. Some powders disperse easily in any of several liquids and remain so while others require careful attention to conditions in order to achieve dispersion and are prone to reaggregate if conditions shift a small amount. A few can be dispersed only after extended treatments.

Agitation, resulting in the application of strong shear forces, aids dispersion. The more violent the agitation, perhaps carried out in a high-speed blender, homogenizer, or an ultrasonic device, the better generally is the dispersion. Stirring a suspension while subjecting it to ultrasonic dispersion generally achieves the best dispersion because this ensures that all portions of the mix are brought into the zones of greatest energy.

For a few friable materials such agitation can result in comminution of the particles for which measurements are preferred. This is not likely to be the case with solid particles, particularly when the particles are under 50 to 100 μm in diameter.

Air bubbles cause misleading results if trapped in the liquid during agitation. Care should be taken to avoid bubble entrapment, especially when the liquid is highly viscous. The SediGraph performs bubble elimination routines and checks to verify their effectiveness, but the best agitation procedure is one that does not introduce them in the first place.

*The procedure for determining the effective density is discussed in Application Note #94. Contact your local sales representative or the Micromeritics sales office to request a copy.

The magnetic stirrer built into the instrument is a convenient means for maintaining a homogeneous particle dispersion but will cause flocculation in certain magnetically susceptible materials. With such particles, stirring can be accomplished by using the ultrasonic dispersion accessory or the MasterTech. Refer to **ORDERING INFORMATION**, page 8-1, for part numbers.

Chemical wetting or dispersing agents also generally aid dispersion. A great variety of such products are marketed. Appendices C and H list some of the more useful dispersing aids, as well as sources for some of these materials. These agents have been found useful for particle dispersion in Micromeritics' Materials Analysis Laboratory but are not the only agents available. It is to be noted that liquid density and viscosity values may need slight adjustment if more than about 0.1% by weight (based on the dry weight of the sample) of dispersing agent is added and precise measurements are needed.

Some commercial surfactants are intended for use in specific pH ranges and in particular nonaqueous solutions. Slight solution composition differences may alter the effectiveness of any agent. The chemical supplier should be contacted about this type of problem. Sometimes merely shifting the pH of an aqueous dispersion will yield great improvements in the degree of dispersion. Metal oxides and metals that are likely to have oxide layers on their surface ordinarily are most easily dispersed in mildly alkaline media. Metal powders with any likelihood of grease on them should always be degreased prior to a dispersion attempt. Noble metal powders usually need a wetting agent for good dispersion. Dispersions involving hydrocarbon liquids that are immiscible with water are often difficult to make unless the powder is quite dry. Sometimes moisture picked up from the air is more than enough to cause difficulties.

Micromeritics offers Sedisperse[®] liquids in three series for dispersing particles at low solids concentrations. A- and P-series are stable, balanced formulations containing highly purified, saturated aliphatic hydrocarbons and added surfactants. A-series Sedisperse liquids are colorless while the P-series are pale yellow. These liquids produce nearly universal dispersion of powder-liquid systems with solids concentrations below three weight percent generally, and as much as five weight percent in some cases. Sedisperse liquids solubilize adsorbed moisture.

W-series Sedisperse liquids are slightly anionic, non-foaming, aqueous formulations. They also produce nearly universal dispersion of systems with concentrations generally below three weight percent. Sedisperse liquids contain built-in surfactants and dispersants so that nothing else needs to be added for the dispersion of particles except mechanical and / or ultrasonic energy. These liquids are available over a range of densities and viscosities, thus making them applicable to particles of widely varying properties. Sedisperse liquids are designed to be used without dilution or the addition of surfactants, and exhibit good shelf life and stability. A data sheet is supplied with each liquid giving handling details, density, and viscosity data over a temperature range of 24 to 45 °C.

The A-series Sedisperse liquids are the most widely useful and will disperse most powders, including metals, oxides, silicates, pigments, Portland cements, propellants, and many other powders. Those few materials not dispersing well in the A-series liquids can usually be dispersed in the P-series Sedisperse liquids. These are special formulations, slightly cationic, developed to disperse difficult metal and pigmented resin powders. The W-series Sedisperse liquids should be used to disperse those materials which are soluble in the organic Sedisperse liquids. See Appendix I for detailed information on Sedisperse liquids.

Some powders flocculate upon standing a few moments after having been dispersed. Such flocculation is quite readily detected with the SediGraph. The indicated size distribution as plotted by the instrument during a test will proceed normally until flocculation starts. The first evidence of flocculation

will likely be an increase in the indicated particle concentration and this will then be followed by a precipitous drop in the plotted percentage. Flocculation, of course, prevents accurate particle size analysis, and better dispersion and stabilization techniques must be sought.

As a general guide, the best dispersing technique (includes agent and procedure) is the one producing consistently the finest distribution of sizes by SediGraph analysis. We make this assertion because of the high reproducibility of the SediGraph when presented identical samples. If the sample preparation technique is deficient in freeing particles one from another or if, though unlikely, is producing particle fracture, this will be evidenced by an inconsistency of results.

The rheological behavior of high concentrations of fine powder in a liquid gives a good preliminary indication of the suitability of both the liquid medium and the dispersing agent. Some powders containing as much as 50 percent liquid act as if they were almost a solid mass, but a few tenths of a percent of wetting agent can cause the mass to take on the consistency of soup. This reaction is indicative of a very good agent. The effect will not often be so dramatic, but working the mass with a spatula will give a good indication of the efficacy of an agent.

A test for the optimum quantity of a dispersing agent is conducted by measuring the sediment volume from a slurry of about 5 weight percent concentration. The slurry and agent must be mixed and allowed to stand in a sedimentation tube undisturbed by either mechanical vibrations or thermal currents. The minimum sediment volume indicates the best agent concentration level. If several dispersing agents are compared at the same time, the minimum sediment volume is also a measure of the best dispersing agent.

No particular sample concentration is required in using the SediGraph as long as the dispersed sample reduces the radiation beam intensity by 13 to 70 percent. The recommended procedure for initial testing is to prepare a dispersion of approximately 5 volume percent concentration. Portions of this preparation are added to pure suspending liquid until an adequate concentration for analysis is achieved. The advantage of this procedure is that less concentrated dispersions can generally be produced without fear of flocculation once the initial preparation is made.

C. CHEMICAL AIDS FOR PARTICLE DISPERSION

Name	Type	Active Ingredient
Aerosol 22	Anionic	Tetrasodium N-(1,2-dicarboxyethyl)-N-octadecylsulfosuccinate, 35%
Aerosol OT	Anionic	Dioctyl ester of sodium sulfosuccinic acid, 70%
Atlas G-3300	Anionic	Amine salt of alkylaryl sulfonate
Calcium Chloride	Cationic	CaCl ₂
Calgon	Anionic	Sodium hexametaphosphate, unadjusted
Calgon T	Anionic	Part of sodium replaced by other cations, predominantly zinc
Cobaltous Chloride	Cationic	CoCl ₂
Cobalt Citrate	Anionic	Co ₃ (C ₆ H ₅ O ₇) ₂
Daxad 23	Anionic	Sodium salt of polymerized carboxylic acid, 25%
Daxad 30	Anionic	Sodium salt of polymerized carboxylic acid, 25%
FC-134	Cationic	Fluorochemical surfactant
FC-161	Anionic	Fluorochemical surfactant
FC-170	Nonionic	Fluorochemical surfactant
Igepal CO-530	Nonionic	Nonylphenoxypoly (ethyleneoxy) ethanol, 100%
Oleic Acid	Anionic	CH ₃ (CH ₂) ₇ CH=CH (CH ₂) ₇ COOH
Renex 648	Nonionic	Ethoxylated nonylphenol, 100%
Sodium Silicate	Anionic	Na ₂ SiO ₃
Triton X-100	Nonionic	Octyl phenoxy polyethoxy ethanol, 100%

Name	Type	Active Ingredient (<i>continued</i>) (<i>continued</i>)
Tamol SN	Anionic	Sodium salt of condensed naphthalene sulfonic acid, 100%
TSPOP	Anionic	Tetrasodiumpyrophosphate, $\text{Na}_4\text{P}_2\text{O}_7$
Twitchell Base 8240	Anionic	Sodium salt of low molecular weight, sulfonated oil, paraffin oil, water, and diethylene glycol
Tween 20	Nonionic	Polyoxyethylene Sorbitan monolaureate (polysorbate 20), 100%
Zonyl S-13	Anionic	Fluoroalkyl phosphate
Zonyl A	Nonionic	Ethylene oxide-ester condensate

Data extracted from McCutcheon's Detergents and Emulsifiers, McCutcheon Division, MC Publishing Co., Glen Rock, NJ, 1980.

D. STOKES' LAW

A particle falling due to gravity in a viscous liquid is acted upon by three forces: a gravitational force acting downward, a buoyant force acting upward, and a drag force acting upward. The descriptive equation of this motion is

$$mg - m_o g - F_D = m_o \frac{dv}{dt} \quad (1)$$

where m is the mass of the particle, m_o the mass of a volume of liquid equal to the volume of the particle, g the acceleration of gravity, F_D the drag force, v the particle velocity, and t the time.

Small particles reach a stable, or terminal, velocity very rapidly; hence, dv/dt quickly becomes zero. The equation of motion for a sphere of diameter D and density ρ falling in a liquid of density ρ_o then becomes

$$F_D = \frac{\pi}{6}(\rho - \rho_o)gD^3 \quad (2)$$

Dimensional analysis reveals that stable particle motion through a liquid is governed by two dimensionless groups: the particle Reynolds number Re

$$Re = Dv \frac{\rho_o}{\eta} \quad (3)$$

where η is the liquid viscosity, and a drag coefficient C_D expressed by

$$C_D = \frac{(\text{drag force})}{(\text{cross-sectional area of particle})(\text{dynamic pressure on particle})} = \quad (4)$$

$$\frac{F_D}{\frac{\pi D^2}{4} \times \frac{\rho_o v^2}{2}}$$

The relationship between Re and C_D for laminar (not turbulent) flow conditions is well established experimentally for low values of the Reynolds number to be

$$C_D = \frac{24}{Re} \quad (5)$$

Combining equations (2) through (5) yields

(6)

$$D^2 = \frac{18v\eta}{(\rho - \rho_o)g}$$

which has come to be identified as the Stokes law equation*.

* Stokes, G.G., *Mathematical and Physical Paper III*, Cambridge University Press, 1891.

E. SEDIMENTATION THEORY

Calculations

Sedimentation size analysis is based upon the fact that the measured equilibrium velocity of a particle through a viscous medium, resulting from the action of the gravitational force, can be related to the size of the particle by Stokes' law. For spherical particles, Stokes' law is expressed by

$$D = Kv^{1/2} \quad (1)$$

where

$$K = \left[18 \frac{\eta}{(\rho - \rho_o)g} \right]^{1/2} \quad (2)$$

and D is the diameter of the spherical particle, v its equilibrium sedimentation velocity, and ρ its density. The fluid medium is characterized by viscosity η and density ρ_o ; g is the acceleration of gravity. These equations apply rigorously as long as the particle Reynolds number, $Dv\rho/\eta$, is less than 0.3 and they apply up to a Reynolds number of 0.5, with about 3% error.*

In practice, truly spherical particles are seldom encountered, and Stokes' law is not exact for any other shape. Since irregular shapes cannot in any case be described by a single linear dimension, it is accepted practice to specify the size of non-spherical particles in terms of the diameter of a sphere of the same material that would have the same sedimentation velocity. Thus, for non-spherical particles, the terms "Stokes' diameter" or "equivalent spherical diameter" are universally understood. The term "equivalent spherical diameter" (E.S.D.) is sometimes used in a different context to mean the diameter of a sphere of the same material that would have the same mass as the particle in question; that is, the results of measurements of particle dimensions from electron micrographs are frequently reduced to size distribution curves in terms of mass E.S.D. In general, the relationship between these two measures of size is given by the inequality

$$\frac{\text{Sedimentation E.S.D.}}{\text{Mass E.S.D.}} \leq 1 \quad (3)$$

The ratio expressed in equation (3) is usually close to unity.

*Lapple, C.E., et al, *Fluid and Particle Mechanics*, University of Delaware, Newark, 1956.

Data on the sedimentation velocity of suspended particles may be obtained in two ways: (a) by measuring the concentration of particles remaining in suspension as a function of time, or (b) by measuring the quantity of sediment produced as a function of time. The latter approach is less desirable mathematically because of the graphical differentiation required to reduce the data to a size distribution curve.

Tests based on the first approach are traditionally performed in the following way. A dilute, dispersion of the fine particle material is stirred to render it homogeneous and then allowed to stand undisturbed while undergoing sedimentation. Time is measured from the beginning of the settling period. By Stokes' law, a particle of diameter D will settle a distance h in time t according to the expression

$$D = K \left(\frac{h}{t} \right)^{1/2} \quad (4)$$

where K is given by equation (2). Consequently, after a given time t_i all particles larger than the corresponding diameter D_i will have fallen below a given distance h from the surface of the suspension. If the initial (uniform) concentration of material is C_o g/cm³ and the concentration after time t_i at distance h is C_i g/cm³, then P_i , the weight percent of material finer than D_i , is given by

$$P_i = 100 \left(\frac{C_i}{C_o} \right) \quad (5)$$

By obtaining values of C_i after various times, the corresponding values of P_i and D_i may be calculated, which when plotted yield an integral, or cumulative distribution of particle size in terms of Stokes' E.S.D.

The SediGraph uses a finely collimated X-ray beam to measure particle concentration in terms of the transmitted intensity of the X-ray beam through the suspension relative to the clear or particle-free suspending fluid. This transmittance is a function of the weight concentration of the suspended solid at the depth of measurement. Since the X-ray beam can be made extremely small and because it does not disturb the suspension, it constitutes an ideal measuring technique.

If a sample container or cell of rectangular cross section is irradiated from a direction perpendicular to one of its sides by a collimated X-ray beam, the fraction of the incident radiation transmitted by the cell when filled with the suspension under study is given by

$$\frac{I}{I_o} = e^{-(a_l \phi_l + a_s \phi_s) L_1 - a_c L_2} \quad (6)$$

where: I and I_o are the transmitted and incident intensities; a_l , a_s , and a_c the X-ray absorption coefficients of the liquid, the particulate solids, and the cell walls, respectively; ϕ_l and ϕ_s the weight fractions of liquid and solid present in the suspension; L_1 the internal cell thickness in the direction of irradiation; L_2 the total thickness of the cell walls. By using the relation $\phi_l = 1 - \phi_s$ and by defining a transmittance T as the ratio of the transmission of the cell when filled with a sample dispersion to its transmission when filled with pure suspending liquid, there is obtained

$$T = e^{-\phi_s(a_s - a_i)L_i} \quad (7)$$

or

$$\ln T = -A\phi_s \quad (8)$$

where A is a constant for the particular apparatus and suspension components.

By collimating the X-ray beam through horizontal slits with a vertical dimension small compared to the sedimentation depth, h, the measured values of T can be used in calculating the particle size distribution; that is,

$$P = 100 \left(\frac{\ln T_i}{\ln T_o} \right) \quad (9)$$

where T_o refers to the transmittance of the initial suspension.

Method of Analysis

Generally, the sedimentation method derives its results from the rates that different size particles fall in a liquid due to the force of gravity. Rate, as used here, is the distance that a particle falls in a certain period of time. The scientific law which describes the rate that particles fall in a liquid is called Stokes' Law. Large particles fall at a faster rate than smaller particles, as shown in the following illustration.

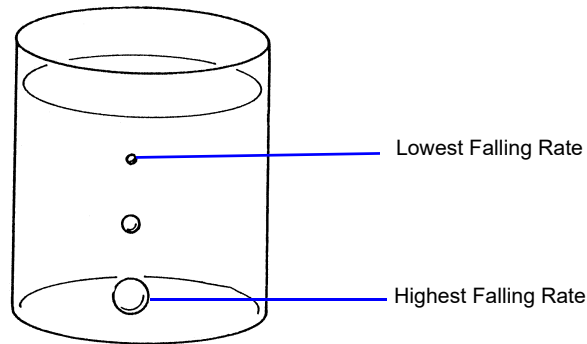

Figure E-1. Particle Size Analysis Using Sedimentation

In order to determine particle diameters accurately using the falling rates of particles, the density and viscosity of the liquid used must be known as well as the density of the particles. Density is the mass of a material that it takes to fill a unit of space. Viscosity may be thought of as the resistance of the liquid applied to falling particles. For example, a particle falls much slower in syrup than in water because syrup has a higher viscosity. It should also be noted that temperature affects both the density and viscosity of liquids; therefore, the temperature of the liquid must be known for particle size determinations to be accurate.

The falling rates for various particle sizes are computed before analysis using Stokes' Law. A vertical distance and an elapsed time are selected for each falling rate such that a particle falling at a certain rate will fall a certain distance in a selected time. Relative particle concentration is then measured at the selected distance and time.

Initially, a completely mixed (homogeneous) suspension of particles is established in a container by rapidly circulating the mixture. The circulation is stopped, and the relative concentrations of particles are measured at the selected vertical distances from the top of the container and at the selected elapsed times after circulation is stopped.

The particle size associated with each concentration measurement is the size of the largest particle present at the height and time of the measurement. All particles larger than that size have higher falling rates, and have fallen to a lower point in the container. Smaller particles are still present at equal concentrations just above and below the specified point. Thus, the concentration measured at the specified point is the concentration of particles smaller than or equal to that size.

This series of relative concentrations of particles smaller than various sizes is the particle size distribution.

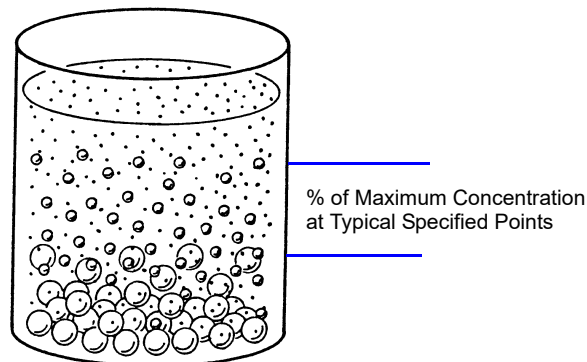

Figure E-2. Particle Size Distribution

Since different particles usually have different shapes, the standard measure used to report particle size is *Equivalent Spherical Diameter*. This is the diameter of a sphere (or perfectly rounded mass) of the same material with the same falling rate.

System Operation

The sedimentation method is used for particle size analysis in the SediGraph. The rates of particle fall due to gravity are calculated and X-ray absorption (concentration) of particles at different heights and points in time are determined, and the results of those determinations are provided as graphs and tabular reports. Sedimentation analysis takes place in the analyzer. Data are sent to the computer which provides the graphs and tabular reports.

The material to be analyzed is dispersed in a liquid, according to the type of analysis to be performed. (For more information concerning the relationship of dispersion to the type of analysis, see appendices B and C.) At the appropriate time, the dispersed mixture is poured into the mixing chamber on the front of the analyzer.

A magnetic stirrer located under the mixing chamber keeps the particles suspended (that is, keeps the particles from sedimenting) until it is time for the analysis. The stirring speed can be adjusted as required to properly suspend the particles. If the particles to be analyzed are attracted to the magnetic stirrer, the magnetic stirrer can be replaced with a mechanical stirrer. If the dispersion energy required to keep the particles in a dispersed state in the mixing chamber is more than can be provided by the stirrer used, an ultrasonic probe can be inserted into the mixing chamber.

Sedimentation takes place inside an analysis cell as shown in the following illustration. At the appropriate time, the particle mixture is transferred by the analyzer from the mixing chamber to the analysis

cell. Particle circulation is stopped, and the particles are allowed to sediment (or fall) inside the analysis cell under the influence of gravity. The SediGraph then determines the particle size distribution.

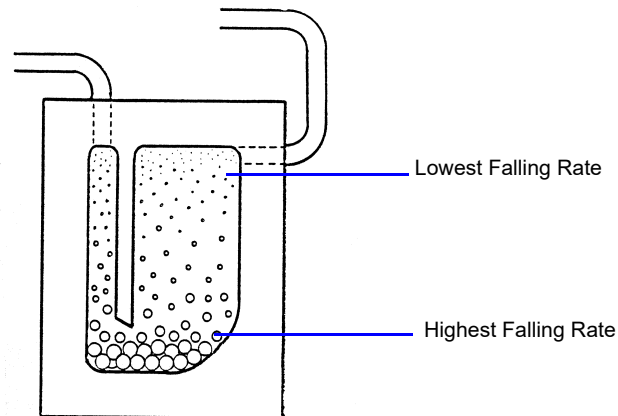

Figure E-3. Analysis Cell

An X-ray beam (made up of a number of fine parallel rays) is provided from a source inside the analyzer. A unit which detects X-rays is placed directly across from the X-ray source. The analysis cell is placed in the path of the X-ray beam, between the X-ray source and the detector. The cell contains a window on each side so that the X-rays can pass through the cell to the detector. Sedimenting particles (particles falling under the influence of gravity) inside the cell cross the path of the X-ray beam. The particles in the path of the beam absorb X-rays (that is, the particles keep some X-rays from reaching the detector). The amount of X-ray absorption at the point in the cell where the beam is located is determined as a percentage of the X-ray absorption with the highest particle concentration for that sample. Based upon particle falling rates, this percentage is related to the maximum particle size above that point in the cell.

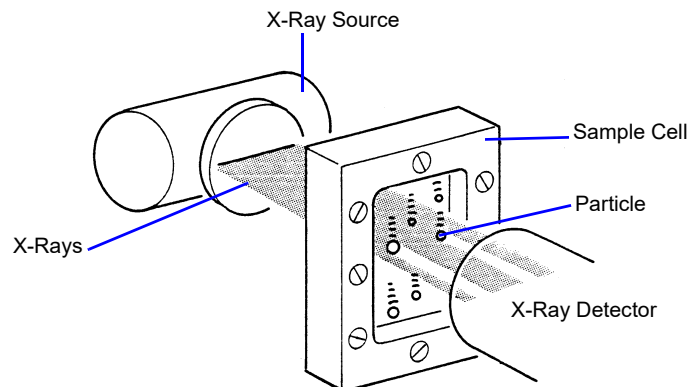

Figure E-4. SediGraph Particle Size Analysis

The SediGraph system uses both particle falling rates and the amount of X-ray absorption for particle size analysis. Particle falling rates (according to Stokes' Law) are used to determine the points in the cell beyond which certain size particles have fallen. X-ray absorption is used to determine the percentage of total particle mass at different points in the cell. The resulting particle size distribution data are processed by the system computer and used to provide graphs and tabular reports which provide details of the analysis.

Particle Falling Rates

Particle falling rates are very significant in the determination of particle size distribution. However, there are several important considerations in the accurate determination of particle falling rates. There must be a reference point for measuring particle falling distances. The SediGraph uses an automatic beam-split feature for establishing a reference point. Small particles have a low falling rate, which could require considerable amounts of time for analysis. The SediGraph uses cell movement during analysis to shorten analysis times by measuring small particle concentration at very short sedimentation distances. Cell movement does not affect particle falling rates within the cell. Particle dispersion also affects falling rates; therefore, proper particle dispersion is required when using the SediGraph.

Beam-Split

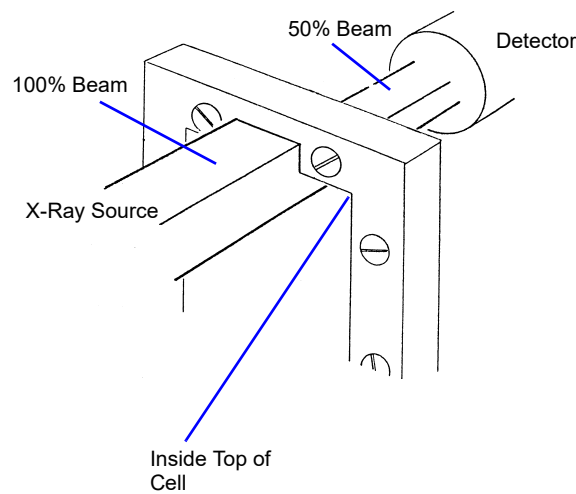

Figure E-5. Beam-Split

Since the top of the cell is used as the reference point for measuring particle falling rates, the exact position of the cell (relative to the X-ray beam) must be known in order for particle falling rates to be correct. The SediGraph determines the position of the cell by moving the cell to the point where the top edge of the cell splits the X-ray beam (exactly in half), and by storing this beam-split data in the system computer so that this position can be located for the next analysis. Beam-split is done automatically by the system at the start of any automatic scanning operation; no message is displayed on the monitor unless beam-split cannot be performed for some reason.

Cell Movement

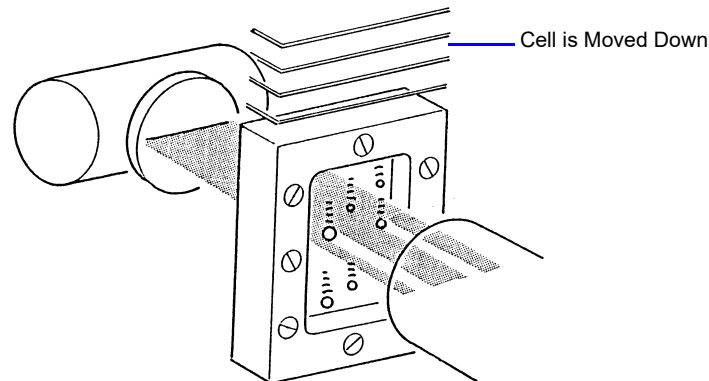

Figure E-6. Cell Movement

The cell is attached to an elevator assembly which moves the cell down during analysis to speed the data collection process. The system computer performs the calculations associated with particle falling rates as the distances and times are changed according to the movement of the cell. For example, as shown in the cell movement illustration, it might take 30 minutes for the particle shown to fall the distance from the top of the cell to the X-ray beam; however, by moving the cell down, the particle reaches the beam in, perhaps, three minutes. The system computer uses this time and distance in determining the particle falling rate.

Particle Dispersion

The particle falling rates also depend upon how well the particles in the cell are dispersed (or separated). Joined particles behave as a single particle with a greater falling rate than if the joined particles were separate (as shown in the following illustration).

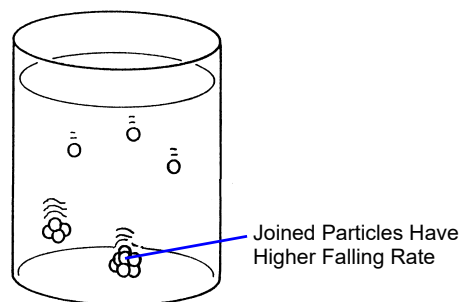

Figure E-7. Affect of Dispersion on Particle Falling Rate

X-Ray Absorption

In addition to particle falling rates, the SediGraph uses the relative amount of X-ray absorption as part of the analysis process. As falling particles in the cell cross the path of the X-ray beam, they absorb X-rays. In order for X-ray absorption to be used for measuring the distribution of particle masses in the cell: (1) the minimum and maximum X-ray absorption must be determined for each X-ray absorption measurement point in the cell; (2) any bubbles in the cell must be detected and eliminated; and (3) the particles must be properly dispersed, as explained in Appendices B and C.

Baseline (Minimum) Absorption

In order for the X-Ray absorption values to be accurate, a reference (or baseline) must be used with each value. This baseline is the amount of X-ray absorption with no particle mass present. However, since the sedimentation liquid also absorbs X-rays, the amount of X-ray absorption for the liquid must be included in the baseline. The shape of the cell, or cell profile, affects the accuracy of baseline X-ray absorption values. The SediGraph automatically determines the baseline and makes baseline corrections for any changes in the shape of the cell. This feature is called baseline correction. Let's look at how it works.

When instructed, the SediGraph performs an X-ray scan of the cell filled only with the selected sedimentation liquid. The reason for this scan is to determine the amount of X-ray absorption of the cell and liquid alone before any particles are introduced. The scan progresses from the bottom of the cell toward the top in exactly the same manner as will be done when sample particles are present.

As the cell is scanned, X-ray absorption reference values (referred to as baseline values) are determined at many points along the cell. The baseline value is the amount of X-ray absorption at that point in the cell. The baseline value is for 0% concentration since the cell contains only the sedimentation liquid and no particles.

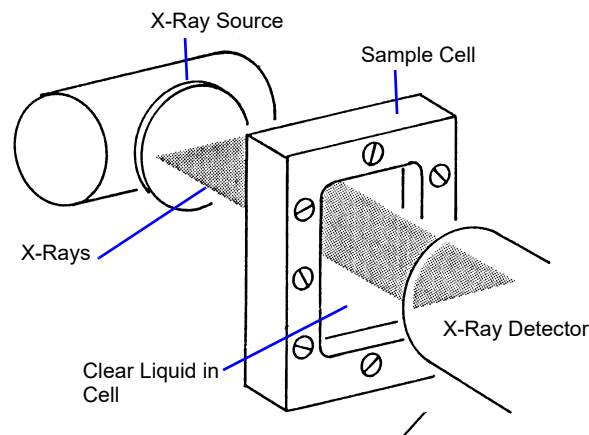

Figure E-8. Baseline (0% Concentration) Absorption

Slight differences in the cell thickness at the measurement points (up to 250) along the cell change the amount of X-ray absorption for those points. The amount of X-ray absorption at each point is stored in the system computer and recalled during the analysis to adjust the baseline at those same points in the cell.

The baseline values do not change unless the sedimentation liquid changes, the shape of the cell changes, or the X-ray intensity changes. It is, however, recommended that you obtain a baseline mea-

surement at the beginning of each shift or whenever a different dispersant (or a new batch) is to be used. This assures accurate analysis results. The baseline operation is selected from the Unit [n] menu.

Full-Scale (Maximum) Absorption

Before each analysis, the SediGraph examines the cell filled with particles suspended in liquid (particles not allowed to sediment). As the cell is being examined, a full-scale X-ray absorption value (or maximum absorption) is determined for each point along the cell as shown in the following illustration. This full-scale absorption value is for 100% concentration, since the cell contains suspended particles, which represents the highest particle concentration for that analysis. The full-scale absorption values change with each analysis since a different number and composition of particles is used.

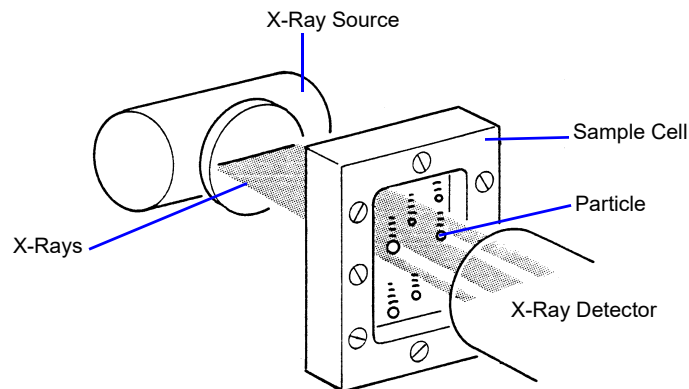

Figure E-9. Full-Scale (Maximum) Absorption

The X-ray absorption is measured at up to 250 positions in the cell. This may be reported on the Baseline / Full scale report. The full scale scan used in the analysis is computed as the average of 10 readings measured at a fixed position.

The full-scale absorption profile operation is performed automatically by the system. Since baseline absorption and full-scale absorption are known for each analysis point in the cell before the analysis, the absorption during the analysis is a percentage somewhere between baseline and full-scale. Using particle falling rate determinations, the system determines the size of the particles which have fallen beyond the specific analysis point in the cell. Therefore, the absorption percentage at each specific analysis point in the cell indicates the percentage of particles that are below a certain particle size. When this is done for a number of points in the cell, the particle size distribution can be determined.

Bubble Detection / Elimination

If air bubbles are formed in the cell during analysis, the amount of X-ray absorption at those points will be detected as a sharp, discrete change. This would make the analysis results invalid. In order to prevent this, the SediGraph has a built-in bubble detection and elimination feature. This feature automatically detects and removes bubbles from the cell. A message is displayed on the screen indicating this operation is in process.

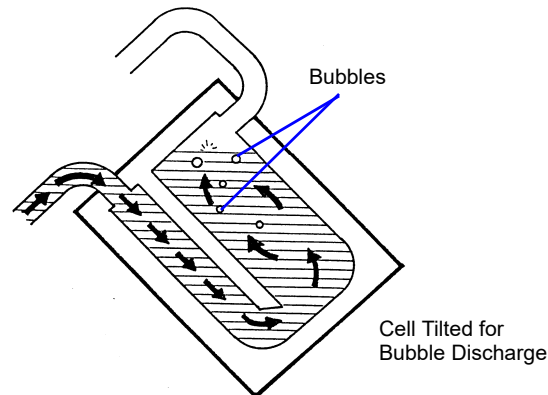

Figure E-10. Bubble Detection / Elimination

F. SEDIGRAPH RESULTS RELATIVE TO OTHER METHODS

The SediGraph 5100 Analyzer, sieve analysis, and hydrometer measurements yield particle size distributions on a mass (weight) basis. Microscopic measurements result in size data as a function of the number of particles. Measurements that involve light scattering, transmission, or diffraction relate size most appropriately to particle cross sectional area. Particle counting systems, electric zone sensing, gives size in terms of particle volume.

Mass-based measurements can be expected to be in agreement with respect to their reliability and the applicability to the size range involved, provided the particles are spherical and solid. When the particles are irregular, close agreement should not necessarily be anticipated. Sieve analysis, for example, must be very carefully performed with fine particles to ensure complete separation according to size without damaging the sieves. Even so, the size determined is not necessarily the same as that measured by the SediGraph. The SediGraph determines the size of all particles in terms of the E.S.D. (equivalent spherical diameter). Since sieve openings are usually square, elongated particles sometimes pass a given sieve in one orientation and at other times are retained. These differences obviously lead to differences in results.

Light-based instruments incorporate various means for tuning, calibrating, and data reduction, which can make them agree satisfactorily for some materials with most any one of the other techniques. Any setting is dependent to a degree on the refractive index of the measured particles, however, so agreement cannot be general or over all particle size ranges. The shape of the particles also influences all results.

Mass and volume measurements are equivalent numerically. Therefore, analyses with the SediGraph and the electric sensing zone can be expected to agree if the particles are spherical, solid, and if their size range is sufficiently narrow for all of them to be accurately detected by the electric sensing zone. Again, precise agreement is not to be expected with irregular particles, for the electric sensing zone measures something closely akin to the diameter an irregular particle would assume were it melted into a sphere. This is not necessarily the equivalent spherical diameter.

Microscopic measurements yield particle diameters that, for spheres, are essentially E.S.D. As before, measured sizes will deviate from E.S.D. when the particles are irregular—the greater the irregularity, the greater the deviation. The numbers will not correspond even approximately because, as noted above, the measurements are on a different basis. However number-based measurements are readily converted into mass-based (or volume-based) results by applying the relationship to incremental sizes,

$$Y = \frac{nD^3}{\Sigma(nD^3)}$$

where Y is the mass percent of particles having the diameter D and n the number of particles of that diameter. The denominator, therefore, represents the entire spectrum of sizes. The following tabulation presents number-based data and calculations leading to the number-based and mass-based diameter distributions.

Comparison of Number and Mass (volume) Size Distributions

Particle Diameter Range (μm)	D Largest Diameter Within Range (μm)	n Number of Particles Within Range	Percent By Number Less Than Diameter	nD^3	$\frac{nD^3}{\Sigma(nD^3)}$	Percent by Mass Less Than Diameter
5.4 - 5.0	5.4	10	100.0	1575	0.0481	100.0
4.9 - 4.5	4.9	51	99.2	6000	0.1833	95.2
4.4 - 4.0	4.4	65	95.3	5537	0.1692	76.9
3.9 - 3.5	3.9	70	90.3	4152	0.1269	59.9
3.4 - 3.0	3.4	133	84.9	5227	0.1597	47.3
2.9 - 2.5	2.9	160	74.6	3902	0.1192	31.3
2.4 - 2.0	2.4	288	62.3	3981	0.1216	19.4
1.9 - 1.5	1.0	271	40.1	1859	0.0568	7.2
1.4 - 1.0	1.4	162	19.2	445	0.0136	1.5
0.9 - 0.5	0.9	72	6.7	52	0.0016	0.2
0.4 - 0	0.4	14	1.1	1	0.0000	0.0
		1296 = Σn		32731 = ΣnD^3		

G. LIQUID DENSITY AND VISCOSITY DATA

Density and viscosity of pure liquids and solutions (aqueous, by weight) as functions of temperature at atmospheric pressure.

Liquid or Solution	Temperature (°C)	Density (g/cm ³)	Viscosity (mPa•s)
Ethanol (absolute)	25	0.7851	1.096
	30	0.7808	1.003
	35	0.7764	0.914
Ethylene Glycol	25	1.1100	16.10
	32	1.1051	12.18
	40	1.0995	9.13
Glycerol (10%)	25	1.0206	1.1530
	30	1.0192	1.0240
	35	1.0178	0.9150
Glycerol (20%)	25	1.0452	1.5430
	30	1.0436	1.3590
	36	1.0400	1.1743
Glycerol (40%)	25	1.0970	3.1860
	30	1.0948	2.7280
	35	1.0926	2.3400
Glycerol (50%)	25	1.1238	5.041
	30	1.1211	4.247
	35	1.1182	3.540
Hexane (n)	25	0.6550	0.3046
	30	0.6504	0.2900
	35	0.6459	0.2828
Isopropanol	30	0.7769	1.7800
	32	0.7752	1.6800
	35	0.7728	1.5400
Sucrose (20%)	20	1.0810	1.945
	30	1.0777	1.493
	40	1.0737	1.184

Liquid or Solution	Temperature (°C)	Density (g/cm ³)	Viscosity (mPa•s)
Sucrose (30%)	20	1.1270	3.187
	30	1.1232	2.373
	40	1.1189	1.833
Sucrose (40%)	20	1.1765	6.167
	30	1.1721	4.375
	40	1.1676	3.241
Sucrose (50%)	20	1.2296	15.43
	30	1.2250	10.11
	40	1.2200	6.991
Water	26	0.9968	0.8737
	32	0.9951	0.7679
	38	0.9930	0.6814
<i>n</i> -Butanol	25	0.8058	2.59
	32	0.8003	2.18
	40	0.7940	1.78

Data extracted from (with interpolation in some cases):

Honig, P., *Principles of Sugar Technology*, p. 31, Elsevier Publishing Co., New York, 1953.

Swindells, J.F., Snyder, C.F., Hardy, R.C. and Golden, P.E., *Viscosities of Sucrose Solutions at Various Temperatures: Tables of Recalculated Values*, Supplement to N.B.S. Circular 440, U.S. Government Printing Office, Washington, 1958.

CRC Handbook of Chemistry and Physics, 59th Edition, The Chemical Rubber Co., Cleveland, OH, 1978-79.

The Merck Index, 9th Edition, Merck & Co., Rahway, NJ, 1976.

H. SOURCES OF DISPERSING AIDS

Dispersant	Source
Aerosol OT Aerosol 22	American Cyanamid Company, Process Chemicals Department, One-T Cyanamid Plaza, Wayne, NJ 07470
Calcium Chloride	Can be purchased at most laboratory supply houses.
Calgon Calgon T	Calgon Corporation, Water Management Division, Calgon Center, P. O. Box 1346, Pittsburgh, PA 15230
Cobalt Citrate	Shepherd Chemical Company, Cincinnati, OH 45212
Cobaltous Chloride	Can be purchased at most laboratory supply houses.
Daxad 23, 30	Hampshire Chemical Corporation, 55 Hayden Avenue, Lexington, MA 02173
Dispex 40	Allied Colloids, 2301 Wilroy Road, Suffolk, VA 23434
FC-134, -161 and -170	3M Company, Chemical Division, St. Paul, MN 55141
Igepal CO-530	GAF Corporation, 1361-T Alps Road, Wayne, NJ 07470
Lomar D	Henkel, 300 Brookside Avenue, Ambler, PA 19002
Oleic Acid	Can be purchased at most laboratory supply houses.
Renex 648 Tween 20 Atlas G-3300	ICI Americas, Inc., Chemical Division, New Concordville Pike, Wilmington, DE 19897
Triton X-100 Tamol SN	Rohm and Haas Company, Independence Mall West, Philadelphia, PA 19105
Sodium Silicate "N" Brand	Philadelphia Quartz Company, 1301-T E. Fort Avenue, Baltimore, MD 21230
Pyrophosphate (TSPP)	Can be purchased at most laboratory supply houses.

Dispersant (<i>continued</i>)	Source
Zonyl A, S-13	E. I. DuPont de Nemours and Company, Dyes and Chemical Division, 1000-T Market Street, Wilmington, DE 19898

I. SEDISPERSE[®] PARTICLE DISPERSION LIQUIDS

Description

Sedisperse A-series and P-series liquids are stable, balanced formulations for dispersing insoluble particles. These liquids are primarily saturated aliphatic hydrocarbons. Sedisperse A-series liquids are colorless while P-series liquids are pale yellow. These liquids produce nearly universal dispersions of powder-liquid systems with solids concentrations below three weight percent and to as much as five weight percent in some cases. Sedisperse liquids solubilize adsorbed moisture.

Sedisperse W-series liquids are slightly anionic, non-foaming, aqueous formulations for dispersing insoluble particles. They also produce nearly universal dispersions of systems with solids concentrations generally below three weight percent.

Sedisperse liquids are non-irritating, non-toxic, non-carcinogenic and non-explosive. The organic Sedisperse liquids will burn, but will not support combustion at room temperature.

Storage Requirements

Keep containers closed. Keep containers from freezing. If a container develops a leak during storage, transfer it to another clean container. Spillage may be cleaned using detergent and water. Sometimes particles may crystallize and settle out of Sedisperse liquids during storage. This is usually a result of exposure to cold temperatures. It is corrected by warming the Sedisperse to 40-50 °C and then vigorously shaking the liquid in a closed container to re-dissolve the particulates. Micro-organisms may also begin to grow in Sedisperse W-series liquids. These can usually be removed by filtering and the liquid is again usable for particle dispersion.

Technical Data

Recommended techniques for using these liquids:

1. Disperse particles using energy from an ultrasonic bath or probe accompanied by continuous, moderate mechanical agitation to force particles through the nodes of the standing ultrasound waves.
2. For sedimentation particle size analysis, first disperse the powder in Sedisperse and estimate the size of the largest particles using a microscope. Next, calculate the liquid viscosity needed by using the relationship

$$\eta = 0.0023 D_{max} \sqrt{D_{max}(\rho - 1)}$$

where

η = minimum viscosity permitted in mPa•s (or cp),

D_{max} = equivalent spherical diameter of the largest particles in μm , and

ρ = density of the particles in g/cm³.

This calculation assumes a particle Reynolds number of 0.1. To convert mPa•s to poise, divide by 10².

Material Properties

A Material Safety Data Sheet (MSDS) is supplied with each purchase. It should be consulted for the following information:

1. Oral Toxicity.
2. Local effect on eyes.
3. Local effect on skin.
4. Shock Sensitivity.
5. Decomposition characteristics.
6. Heat generation characteristics.
7. Recommended extinguishing agents.
8. Hazard by inhalation.

First Aid Treatment

The Material Safety Data Sheet (MSDS) supplied with each liquid should be consulted for the following first aid information:

1. Skin contact.
2. Eye contact.
3. Inhalation.
4. Antidote in case of swallowing.

J. DATA REDUCTION

Data Acquisition

The basic data acquired are in the form of cumulative mass percent finer vs. diameter. An explanation of the method for acquiring the data is provided below.

Diameter

Diameter for a given set of sedimentation conditions is given by Stokes equation as follows

$$D = \left[\frac{18\eta}{(\rho - \rho_o)g} \right]^{1/2} \times \left[\frac{h}{t} \right]^{1/2}$$

where

D	=	diameter (cm, multiply by 10000 for micrometers)
η	=	liquid viscosity (poise, multiply by 0.01 for cp)
h	=	sedimentation height (cm)
ρ	=	sample density (g/cm ³)
ρ_o	=	liquid density (g/cm ³)
g	=	acceleration due to gravity (981 cm/s/s)
t	=	sedimentation time (sec)

All data are acquired at one of 220 predetermined sedimentation heights, ranging from 2.54 cm to 0.0079375 cm.

Sample density is user-entered. Liquid viscosity and density are user-entered, or they are calculated using the sedimentation cell temperature and interpolating from the user-selected Liquid Properties Set (see Liquid Properties Interpolation).

Target diameters for data collection are determined as follows:

Up to 250 target diameters are selected, evenly spaced on a log diameter basis, between the user-selected starting diameter and ending diameter. Note that this gives the operator some choice in the resolution of the data relative to the log diameter axis: selecting a narrower range of analysis provides more data points in a given range of diameters. Maximum resolution is obtained by selecting starting and ending diameters spanning only one decade (factor of 10), providing 250 data points per decade resolution.

Target sedimentation heights and times are selected based on run type (high speed, standard, or high resolution) and Stokes' equation.

During analysis, mass % data will be taken at these target heights, and as close to these target times as possible, allowing for cell movement, data acquisition delay time, and sequential collection of data

points. The actual time of data collection will be recorded for each point, so that actual diameter may be calculated later.

Height, time, density, and viscosity data are stored separately, so that corrections to density and viscosity can be made after the analysis and diameters are recalculated.

Liquid Properties Interpolation

The density and viscosity of the sedimentation liquid at the time of analysis are interpolated as follows, using a liquid properties table of three points of density and viscosity versus temperature, and the cell temperature reading at the start of analysis.

Density

$$B = \frac{((d2 - d1) - (d3 - d1) \times ((t2 - t1) / (t3 - t1)))}{(d1 \times (2 - t3))}$$

$$A = (1 - (d2/d1) + B \times (t2 - t1)^2) / (t2 - t1)$$

$$\rho_o = d1 \times (1 - A \times (tc - t1) + B \times (tc - t1)^2)$$

where

t1, t2, t3	=	temperatures from liquid properties table (degrees C)
d1, d2, d3	=	densities at t1, t2, t3 respectively (g/cc)
A	=	first order coefficient
B	=	second order coefficient
tc	=	cell temperature reading at start of analysis (degrees C)
ρ_o	=	liquid density at analysis temperature (g/cc)

Viscosity

$$C = (v1 \times (1 - ((t1 - t2)/(t1 - t3))) - v2 + v3 \times (t1 - t2)/(t1 - t3)) / ((t1 - t2) \times (t2 - t3))$$

$$B = (v1 - v2 - (C \times (t1^2 - t2^2))) / (t1 - t2)$$

$$A = v1 - (B \times t1) - (C \times t1^2)$$

$$\eta = e^{(A + B/TK) + (C/TK^2)}$$

where

- t1, t2, t3 = 1/(t + 273.15) for t = each of the 3 temperatures in the liquid properties table (t in degrees C)
- v1, v2, v3 = ln(v) for v = each of the 3 viscosities (cp)
- A, B, C = 0th, 1st, and 2nd order coefficients, respectively
- TK = cell temperature at start of analysis (degrees K, i.e. 273.15 + degrees C)
- η = viscosity at analysis temperature (cp)

Mass Percent

The mass percent of sample present at a given sedimentation height after a given time is determined by relating the x-ray transmission intensity at that point to the intensity with no sample present (baseline), and the intensity with all of the sample present (full scale):

$$\text{mass \%} = (\log(I_m) - \log(I_b)) / (\log(I_f) - \log(I_b)) \times 100$$

where

I_m = intensity at data point (mass % being determined)

I_b = intensity at baseline (mass % = 0)

I_f = intensity at full scale (mass % = 100)

The I_b and I_f values are average values to minimize random variations in the X-ray intensity. The average of these values is used to compute the mass percent.

One set of baseline data may be used for scaling multiple analyses until another set of baseline data are collected.

After the sample is loaded while the cell pump is still on and the sample fully suspended and evenly distributed throughout the cell, bubble elimination data are collected at between 110 and 220 predetermined analysis heights, based on the type of bubble elimination selected. In addition, a single average full-scale value is computed at the starting analysis height.

Mass percent data appearing on the ‘Analysis Results’ screen has been smoothed with an 11-point evenly weighted running average.

When data are saved permanently after all analyses on a sample are completed, the mass percent values are smoothed before storage in the sample file as follows:

The mass percent values are smoothed with an 11-point running average, just as for the ‘Analysis Results’ screen. From these data, a set of mass percent values are interpolated at 250 evenly spaced intervals on a log diameter basis, using linear interpolation between the two adjacent collected points to get each evenly spaced point. This is done because the next smoothing step requires evenly spaced data points, and the collected data can vary from even log diameter spacing due to limitations on time of collection, as noted above.

The evenly spaced mass percent values are smoothed using a digital filter which removes high-frequency variations from the data. The final, stored mass percent values are obtained by interpolating to a standard size table with 40 logarithmically, evenly-spaced sizes per decade.

Reduction of Collected Data

Mass Data

In order to obtain cumulative mass percent data, the smoothed mass percent data scaled to the specified full scale value:

For each of the total number of points collected,

$$\text{CumMassFiner (\%)} = \text{MassFiner} \times \frac{\text{FullScale}}{100.0}$$

Cumulative mass percent coarser data are simply the difference of scaled mass percent finer data from 100:

For each of the total number of points collected

$$\text{CumMassCoarser (\%)} = 100.0 (\%) - \text{CumMassFiner (\%)}$$

These cumulative mass data (finer and coarser) are represented directly in tabular form and as y-axis data in the CUMULATIVE MASS FINER VS. DIAMETER and CUMULATIVE MASS COARSER VS. DIAMETER plots (cumulative mass distribution curve). Also, cumulative mass data are used to derive mass frequency and log probability data.

Mass Frequency Data

The mass frequency of a particle size interval is the difference between the cumulative mass percent interpolated at the end points of the interval. The interpolation is performed using a spline fit to the cumulative mass data.

Cumulative Data

Any cumulative quantity can be expressed as *Coarser* or *Finer* (Retained or Passed on the Tabular Report by Sieve Size).

For data defined by the standard class sizes (Summary, Tabular Defined by Size Class, and Graphs):

$$\text{CumFracCoarser}_i = \sum \text{FreqFrac}_k \text{ for all classes } k \text{ such that } \text{AvgDiam}_k > \text{AvgDiam}_i$$

$$\text{CumFracFiner}_i = \sum \text{FreqFrac}_k \text{ for all classes } k \text{ such that } \text{AvgDiam}_k < \text{AvgDiam}_i$$

$$\text{CumFracRetain}_i = \sum \text{FreqFrac}_k \text{ for all classes } k \text{ such that } \text{AvgDiam}_k \geq \text{AvgDiam}_i$$

$$\text{CumFracPass}_i = \sum \text{FreqFrac}_k \text{ for all classes } k \text{ such that } \text{AvgDiam}_k < \text{AvgDiam}_i$$

or equivalently,

$$\text{CumFracFiner}_i = 1.0 - \text{CumFracCoarser}_{i-1}$$

$$\text{CumFracRetain}_i = \text{CumFracCoarser}_{i-1}$$

$$\text{CumFracPass}_i = 1.0 - \text{CumFracCoarser}_{i-1}$$

For Tabular Defined by SizeTable or by Sieve Sizes:

CumFrac (Coarser or Finer, Retained or Passed) is calculated for the standard size classes as defined above. CumFrac is then interpolated from CumFrac vs. Particle Size at each particle size in the Size table or aperture size in the Sieve table.

Peak Report Data

Peak report data are calculated as:

$$\text{DiffFreqFrac}_i = \frac{\text{FreqFrac}_i}{\log\left(\frac{\text{HighDiam}_i}{\text{LowDiam}_i}\right)}$$

Starting at the small particle size end of the frequency distribution:

1. Scan DiffFreqFrac_i for a local maximum, i.e.,

$$\text{DiffFreqFrac}_k > \text{DiffFreqFrac}_{k+1}, \text{ and}$$

$$\text{DiffFreqFrac}_k > \text{DiffFreqFrac}_{k-1}$$

$AvgDiam_k$ is the mode of the candidate peak.

2. Scan $DiffFreqFrac_i$ from class k toward smaller particle sizes to find a local minimum, i.e.,

$DiffFreqFrac_m = 0$, or

$DiffFreqFrac_m < DiffFreqFrac_{m+1}$ and $DiffFreqFrac_m < DiffFreqFrac_{m-1}$

$LowDiam_m$ is the low diameter of the candidate peak .

3. Scan $DiffFreqFrac_i$ from class k toward larger particle sizes to find a local minimum, i.e.,

$DiffFreqFrac_n = 0$, or

$DiffFreqFrac_n < DiffFreqFrac_{n+1}$ and $DiffFreqFrac_n < DiffFreqFrac_{n-1}$

$HighDiam_n$ is the high diameter of the candidate peak.

4. Sum values of $FreqFrac_i$ from $i=m$ to $i=n$.

If the sum is greater than or equal to the Minimum Fraction to Report, the candidate peak is qualified and the sum is the Fraction of Distribution. Other peak quantities are calculated using the same formulas as for the entire distribution, except the only range from class m to class n is used.

Otherwise, the candidate peak is disqualified.

In either case, peak identification repeats from step 1, starting with class n. When the end of the distribution is reached by scanning in either step 1 or step 3, peak identification is complete.

In step 1 if the end of the distribution is reached on an increasing frequency slope, i.e., $DiffFreqFrac_k > DiffFreqFrac_{k-1}$, then class k is treated as the mode of a candidate peak and as the high size end of the candidate peak.

If the beginning or end of the distribution is reached while scanning for a local minimum in step 2 or 3, the beginning or ending class is treated as the local minimum.

For calculating Standard Deviation for N tests, peaks from the various tests are simply matched by their order, i.e., peak 1 from test 1 is matched with peak 1 from test 2, etc. If all tests do not have the same number of peaks, Standard Deviation for N tests is reported as N/A (not available). If the peak numbers are not the same and the user chose average of n tests, a single row is filled in with all N/A (including the peak number).

Number Frequency Data

The number frequency is computed from the mass frequency distribution as defined by the standard size classes.

For each class:

$$\text{NumFreq}_i = \frac{\text{MassFreq}_i / \text{AvgDiam}_i^3}{\sum_k \text{MassFreq}_k / \text{AvgDiam}_k^3}$$

where

NumFreq_N = Number frequency for class N

MassFreq_N = Mass frequency for class N

AvgDiam = Average diameter for class N

The cumulative number percent for a class is computed as the summation of the non-negative frequencies for all smaller classes.

Surface Area Frequency Data

The surface area frequency is computed from the mass frequency distribution as defined by the standard size classes.

$$\text{AreaFreq}_i = \frac{\text{MassFreq}_i / \text{AvgDiam}_i}{\sum_k \text{MassFreq}_k / \text{AvgDiam}_k}$$

For each class:

where

AreaFreq_N = Number frequency for class N

MassFreq_N = Mass frequency for class N

AvgDiam = Average diameter for class N

The cumulative number percent for a class is computed as the summation of the non-negative frequencies for all smaller classes.

Size Statistics

Standard Deviation of Quantity for N Tests

For quantity, substitute the variable name for which the standard deviation is being determined. The subscript k refers to the test number.

If NumTests \leq 1, StdDevTestQuantity = 0.

Otherwise,

$$\text{MeanTestQuantity} = \frac{\sum \text{Quantity}_k}{\text{NumTests}}$$

$$\text{StdDevTestQuantity} = \sqrt{\frac{\sum (\text{Quantity}_k - \text{MeanTestQuantity})^2}{\text{NumTests} - 1}}$$

Mode

In order to do a mode calculation, the definition of the standard classes is extended over the range of input for all the data; frequencies are calculated for these classes. It is this frequency data that is used in determining the peak quantities so that all the classes are of the same width.

ModeDiam = AvgDiam_i such that DiffFreqFrac_i is the maximum DiffFreqFrac

Median

MedianDiam = Diameter interpolated from HighDiam vs. CumFracCoarser at CumFracCoarser = 0.5.

If the calculation is being performed on a peak, the interpolation point is at CumFracCoarser = (CumFracCoarser_m + CumFracCoarser_n)/2.

Arithmetic Calculations

Mean

$$\text{MeanDiam} = \frac{\sum \text{FreqFrac}_i \cdot \text{AvgDiam}_i}{\sum \text{FreqFrac}_i}$$

Standard Deviation (of the distribution)

$$\text{StdDevDiam} = \sqrt{\frac{\sum \text{FreqFrac}_i (\text{AvgDiam} - \text{MeanDiam})^2}{\sum \text{FreqFrac}_i}}$$

Coefficient of Variation

$$\text{CoefVar} = \frac{\text{StdDevDiam}}{\text{MeanDiam}}$$

Skewness

$$\text{Skew} = \frac{\sum \text{FreqFrac}_i (\text{AvgDiam}_i - \text{MeanDiam})^3 / \sum \text{FreqFrac}_i}{(\sum \text{FreqFrac}_i (\text{AvgDiam}_i - \text{MeanDiam})^2 / \sum \text{FreqFrac}_i)^{3/2}}$$

Kurtosis

$$\text{Kurt} = \frac{\sum \text{FreqFrac}_i (\text{AvgDiam}_i - \text{MeanDiam})^4 / \sum \text{FreqFrac}_i}{(\sum \text{FreqFrac}_i (\text{AvgDiam}_i - \text{MeanDiam})^2 / \sum \text{FreqFrac}_i)^2} - 3$$

+xσ

$$\text{PlusNSig} = \text{MeanDiam} + x \cdot \text{StdDevDiam}$$

where x is a user-selected number.

-xσ

$$\text{MinusNSig} = \text{MeanDiam} - x \cdot \text{StdDevDiam}$$

where x is a user-selected number.

Geometric Calculations

Mean

$$\frac{\sum(\text{FreqFrac}_i \log(\text{AvgDiam}_i))}{\sum \text{FreqFrac}_i}$$

$$\text{GeoMeanDiam} = 10$$

Standard Deviation (of the distribution)

$$10^{\text{StdDevLogDiam}}$$

Standard Deviation of Log

$$\text{StdDevLogDiam} = \sqrt{\frac{\sum \text{FreqFrac}_i (\log(\text{AvgDiam}) - \log(\text{GeoMeanDiam}))^2}{\sum \text{FreqFrac}_i}}$$

Skewness of Log

$$\text{SkewLog} = \frac{\sum \text{FreqFrac}_i (\log(\text{AvgDiam}_i) - \log(\text{GeoMeanDiam}))^3 / \sum \text{FreqFrac}_i}{(\sum \text{FreqFrac}_i (\log(\text{AvgDiam}_i) - \log(\text{GeoMeanDiam}))^2 / \sum \text{FreqFrac}_i)^{3/2}}$$

Kurtosis of Log

$$\text{KurtLog} = \frac{\sum \text{FreqFrac}_i (\log(\text{AvgDiam}_i) - \log(\text{GeoMeanDiam}))^4 / \sum \text{FreqFrac}_i}{(\sum \text{FreqFrac}_i (\log(\text{AvgDiam}_i) - \log(\text{GeoMeanDiam}))^2 / \sum \text{FreqFrac}_i)^2} - 3$$

+xσ

$$\text{PlusNSigLog} = 10^{\log(\text{GeoMeanDiam}) + x \log(\text{GeoStdDevDiam})}$$

-xσ

$$\text{MinusNSigLog} = 10^{\log(\text{GeoMeanDiam}) - x \log(\text{GeoStdDevDiam})}$$

Specification / Reference Quantities

Out of Spec

SampCumFrac_i = cumulative fraction coarser/finer/passed/retained for class i from sample distribution

$\text{CoarseSpecCumFrac}_i$ = cumulative fraction coarser/finer/passed/retained for class i from Coarse Specification distribution interpolated if the bins are of different size. This is always the average of all tests in the named sample file.

FineSpecCumFrac_i = cumulative fraction coarser/finer/passed/retained for class i from Fine Specification distribution interpolated if the bins are of different size. This is always the average of all the tests in the named sample file.

If $\{\text{SampCumFracCoarser}_{i-1} > \text{CoarseSpecCumFracCoarser}_{i-1}\}$

$$\text{OutSpecFracCoarser}_i = \text{SampCumFracCoarser}_{i-1} - \text{CoarseSpecCumFracCoarser}_{i-1}$$

If $\{\text{SampCumFracCoarser}_{i-1} < \text{FineSpecCumFracCoarser}_{i-1}\}$

$$\text{OutspecFracCoarser}_i = \text{SampCumFracCoarser} - \text{FineSpecCumFracCoarser}_{i-1}$$

or,

$$\text{OutSpecFracFiner}_i = -\text{OutSpecFracCoarser}_{i-1}$$

$$\text{OutSpecFracRetain}_i = \text{OutSpecFracCoarser}_{i-1}$$

$$\text{OutSpecFracPass}_i = \text{OutSpecFracCoarser}_{i-1}$$

Difference from Reference

SampCumFrac_i = cumulative fraction coarser/finer/passed/retained for class i from sample distribution

RefSpecCumFrac_i = cumulative fraction coarser/finer/passed/retained for class i from Reference Specification distribution interpolated if the bins are of different size. This is always the average of all the tests in the named sample file.

$\text{DiffRefCoarser}_i = \text{SampCumFrac}_i - \text{RefCumFrac}_i$

or,

$\text{DiffRefFiner}_i = \text{DiffRefCoarser}_{i-1}$

$\text{DiffRefRetain}_i = \text{DiffRefCoarser}_{i-1}$

$\text{DiffRefPass}_i = \text{DiffRefCoarser}_{i-1}$

Maximum Out of Spec

$\text{MaxOutSpecFrac} = \text{maximum (abs value (OutSpecFrac}_i))$

Pass / Fail by Specification

If $\text{MaxOutSpecFrac} = 0$, $\text{PassFail} = \text{Passed by Specification}$

Otherwise, $\text{PassFail} = \text{FAILED by Specification}$

SPC Report Variables

Regression Chart

The line of best for the Regression Chart is calculated by the usual least squares method. If there is only a single point, or all N points have the same x-value, there can be no line of best fit in the standard form.

$$XAve = \frac{\sum x_i}{N}$$

$$YAve = \frac{\sum y_i}{N}$$

$$Slope = \frac{\sum (x_i - XAve)(y_i - YAve)}{\sum (x_i - XAve)^2}$$

$$YIntercept = YAve - Slope \cdot XAve$$

The coefficient of correlation for this line also is calculated in the usual

$$\text{way.} * \sigma_x = \sqrt{\frac{\sum (x_i - XAve)^2}{N}}$$

$$\sigma_y = \sqrt{\frac{\sum (y_i - YAve)^2}{N}}$$

* Mathematical Handbook for Scientists and Engineers, G.A., Korn and T.M. Korn, McGraw Hill, Sec. 18.4 (1968).

$$\text{Cov}(x,y) = \frac{\sum (x_i - XAve)(y_i - YAve)}{N}$$

$$\text{CorrelationCoef} = \frac{\text{Cov}(x,y)}{\sigma_x \sigma_y}$$

Control Chart

$$Mean = \frac{\sum y_i}{N}$$

$$StdDev = \sqrt{\frac{\sum (y_i - Mean)^2}{N - 1}}$$

$$CoefVar = \frac{StdDev}{Mean}$$

$$PlusNSig = Mean + n \cdot StdDev$$

$$MinusNSig = Mean - n \cdot StdDev$$

Reynolds Number

The Reynolds Number is calculated as follows:

$$\text{Reynolds Number} = \left[\frac{D(\mu m)}{10000(\mu m / cn)} \right]^3 \times \left[\frac{\rho_o(\text{g/cc}) \times (\rho - \rho_o)(\text{g/cc}) \times g(\text{cm/s/s})}{K \times (\eta(\text{cp}) \times 0.01 (\text{poise/centipoise})) \times 2^2} \right]$$

where

- D = specified starting diameter,
- ρ_o = liquid density,
- ρ = sample density,
- η = liquid viscosity,
- g = acceleration due to gravity, and
- K = Stokes' constant = 18.

The Reynolds Number is displayed on the tabular report.

Log Probability Data

Log probability data are a transformation of cumulative mass finer data as a means of determining how well cumulative and differential mass data represent statistical normal distributions. Since cumulative mass finer data are essentially data indicating the probabilities of finding particles of mass finer at given diameters, log normal probability data are a fit of the cumulative mass data to the defined, symmetrical probabilities tabulated for a normal distribution.

The log probability table used is a subset of 99 points, ranging from (-2.88, 0.2%) to (0.0, 50.0%) to (+2.88, 99.8%), from a standard normal distribution table (see log probability interpolation table). The x-axis and y-axis data which are plotted on a log probability graph are calculated as follows:

1. X-axis boundaries are determined by the spline interpolation at 0.2% and 99.8% from cumulative mass finer vs. log diameter. This gives Xprob_beg and Xprob_end, respectively.
2. For each of the number of points collected,

If Diameter value is between Xprob_beg and Xprob_end and

if CumMassFiner value is between 0.2% and 99.8%, then

Xprob value = Diameter value

Yprob value = Spline interpolation at CumMassFiner values of the x vs. y log probability table values

Log Probability Interpolation Table

X(%)	Y	X(%)	Y	X(%)	Y
0.20	-2.88	33.00	-0.44	68.08	0.47
0.99	-2.33	34.83	-0.39	69.15	0.50
2.02	-2.05	35.94	-0.36	69.85	0.52
3.01	-1.88	37.07	-0.33	70.88	0.55
4.01	-1.75	37.83	-0.31	71.90	0.58
4.95	-1.65	38.97	-0.28	72.91	0.61
5.94	-1.56	40.13	-0.25	73.89	0.64
6.94	-1.48	40.90	-0.23	74.86	0.67
7.93	-1.41	42.07	-0.20	76.11	0.71

X(%)	Y	X(%)	Y	X(%)	Y
9.01	-1.34	42.86	-0.18	77.04	0.74
10.03	-1.28	44.04	-0.15	77.94	0.77
10.93	-1.23	44.83	-0.13	79.10	0.81
11.90	-1.18	46.02	-0.10	79.95	0.84
12.92	-1.13	46.81	-0.08	81.06	0.88
14.01	-1.08	48.01	-0.05	82.12	0.92
14.92	-1.04	48.80	-0.03	82.89	0.95
16.11	-0.99	50.00	0.00	83.89	0.99
17.11	-0.95	51.20	0.03	85.08	1.04
17.88	-0.92	51.99	0.05	85.99	1.08
18.94	-0.88	53.19	0.08	87.08	1.13
20.05	-0.84	53.98	0.10	88.10	1.18
20.90	-0.81	55.17	0.13	89.07	1.23
22.06	-0.77	55.96	0.15	89.97	1.28
22.96	-0.74	57.14	0.18	90.99	1.34
23.89	-0.71	57.93	0.20	92.07	1.41
25.14	-0.67	59.10	0.23	93.06	1.48
26.11	-0.64	59.87	0.25	94.06	1.56
27.09	-0.61	61.03	0.28	95.05	1.65
28.10	-0.58	62.17	0.31	95.99	1.75
29.12	-0.55	62.93	0.33	96.99	1.88
30.15	-0.52	64.06	0.36	97.98	2.05

X(%)	Y	X(%)	Y	X(%)	Y
30.85	-0.50	65.17	0.39	99.01	2.33
31.92	-0.47	67.00	0.44	99.80	2.88

Standard Report Tables

Standard Diameter	Standard Mass %
300	95
250	90
200	85
150	80
100	75
80	70
60	65
50	60
40	55
30	50
25	45
20	40
15	35
10	30
8	25
6	20
5	15
4	10
3	5

Standard Diameter	Standard Mass %
1.5	
1	
0.8	
0.6	
0.5	
0.4	
0.3	
0.2	
0.1	

K. SEDIGRAPH X-RAY SAFETY INFORMATION

In a continuing effort to provide maximum safety to operators of Micromeritics equipment, and to ensure full compliance with all known government safety regulations regarding X-rays, Micromeritics provides a high level of X-ray safety on its SediGraph line.

General

The SediGraph Particle Size Analysis System employs soft X-rays to detect relative particle concentration because X-ray absorption is directly proportional to particle mass. This X-ray beam is inaccessible to the operator at all times due to cabinet construction, a door enclosing the cell compartment, a mechanical shutter that blocks the beam's entry into the cell compartment when that door is opened more than 12 mm (0.5 in.), and electrical interlocks that interrupt power to the X-ray tube when the cell compartment door or top panel is opened.

X-ray Source

X-rays are generated by a small, air-cooled tube having a tungsten target inclined at 55° to a thin beryllium window. It is operated at a potential of 13,600 VDC with a power input of less than 41 Watts. The greatest value the anode voltage can attain in a malfunction is 15,000 VDC. Only the tungsten L-lines are excited, of which the L is primary. This primary radiation has an energy of approximately 10,000 eV and a corresponding wavelength of 0.125 nm (1.25 angstroms). The integrated radiation density of the direct, unattenuated beam over a 25-mm circular aperture is between 300 and 400 milliroentgens per hour. The X-ray beam is, for example, 60% blocked by a 51 µm (0.002 in.) thick film of the plastic polyvinyl chloride and essentially completely blocked by 130 µm (0.005 in.) thick steel. Nevertheless, the shutter mechanism should never be defeated.

Radiation levels outside the instrument or in the cell compartment when the compartment door is open are well below 0.5 milliroentgen per hour. **Most jurisdictions require the registration of radiation producing devices regardless of kind or intensity level.** Check with the appropriate authority in your area*.

Since a potential of 13,600 VDC and a current of up to 3 mA generate the X-rays, the instrument should be unplugged before any panel is removed for any purpose. This ensures that X-ray generation ceases and high voltages are eliminated.

*Based on the above information, SediGraph users in the State of Georgia have regularly been granted waivers to the State of Georgia "Rules and Regulations for X-Ray" by the Radiological Health Section of the Georgia Department of Human Resources.

Warning / Indicator Lights

The SediGraph control switches and indicators are located on the front panel of the analytical unit and include a keyswitch to turn the X-ray tube on. The key is held captive when the keyswitch is on. There are two warning lights: An amber X-RAY STANDBY light and a red X-RAY ON light. With the analytical unit connected to the electric mains and the power switch on, the amber X-RAY STANDBY light is lit. Turning the keyswitch to the ON position causes the red X-RAY ON light to illuminate signaling that power is applied to the X-ray tube. When the X-RAY ON light is illuminated, power is applied to both the filament and anode of the X-ray tube. If the X-RAY ON lamp filament burns out, then power is interrupted to both the filament and anode of the X-ray tube. In order for power to be supplied to the X-ray tube filament and anode when a failure (open circuit) occurs in the X-RAY ON light, concurrent failures must occur in two independent circuits such that these circuits continue to supply power to the X-ray tube.

The SediGraph has magnetically actuated reed switches. These switches are in series with the X-RAY ON lamp filament. Whenever the top or back panel of the SediGraph is removed, the cell-compartment door is opened, the fluid module is removed, or the X-RAY ON lamp filament burns out (opens), both filament and anode power to the X-ray tube are interrupted.

These switches are in addition to the mechanical shutter which operates when the cell compartment door is opened, blocking X-rays and removes filament power when the top cover is removed. During the last 12 mm (0.5 in.) of travel of the cell compartment door to the fully closed position, the sliding pin actuates the gravity-operated, spring-assisted shutter so that the shutter is opened to allow X-rays to enter the cell compartment. When the cell compartment door is opened from the fully closed position, the shutter is actuated during the first 12 mm (0.5 in.) of travel to close and block x-rays from entering the cell compartment. As long as the cell compartment door remains open, the shutter blocks X-rays from entering the cell compartment and the X-Ray Detection Indicator remains off.

Now, when the cell compartment door is opened, not only does the shutter block the X-ray beam but the power to the X-ray tube also is interrupted.

L. MASTERTECH INSTALLATION

The MasterTech should be correctly installed and checked to make sure that it is operating properly before actual analyses are attempted.

Removing Packing Material From the Unit

After removing the MasterTech from the shipping carton, remove all foam packing material from the unit before proceeding with installation.

Selecting the Voltage

The MasterTech 052 leaves the factory set for 120 VAC and with the line fuse removed. The correct setting of the universal power entrance must be checked and the appropriate fuse installed before the MasterTech can be operated. The MasterTech is designed to operate with either 100, 120, 220 or 240 VAC at 50 or 60 Hz. Voltage selection and fusing are made at the power connector which is located on the rear panel of the unit.



The power cord should be disconnected from the MasterTech before removing the cover from the power input connector. Failure to disconnect the power cord could result in electrical shock.

1. Ensure the power cord is disconnected from the MasterTech.
2. Using a pointed object, remove the fuse block and cover assembly from the power connector at the rear of the MasterTech.

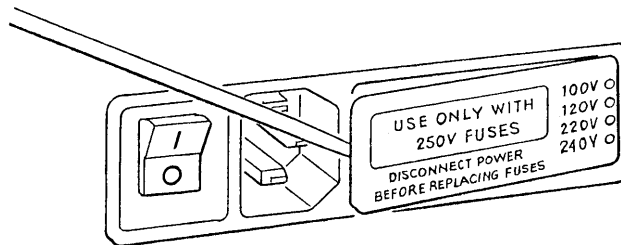

3. Pull the voltage selector card straight out of the power connector housing.

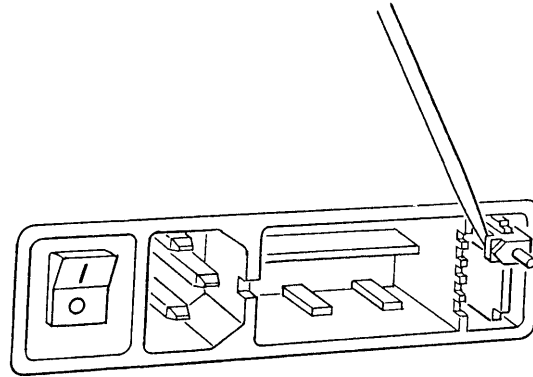

4. Orient the voltage selector card so that the proper voltage is indicated at the bottom. Orient the indicator pin so that it points upward as shown in the following illustration.

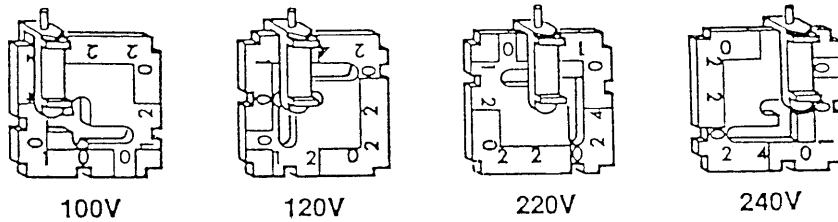

5. Insert the voltage selector card into the power connector housing with the edge containing the proper voltage first and with the printed side facing the power ON/OFF switch.

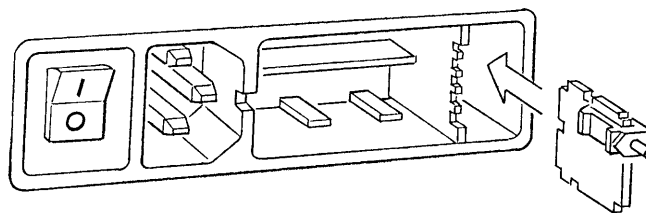

6. Fuse the input power line according to local safety practices. The input power connector can be used with either a single-fuse arrangement or a double-fuse arrangement, as shown in the following illustration.

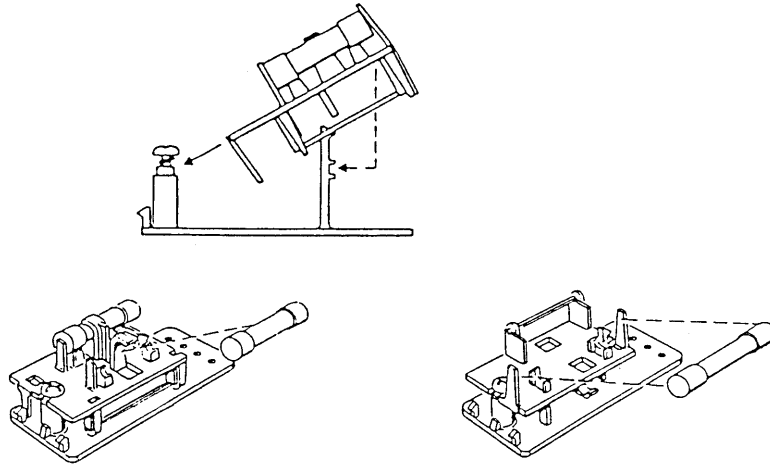

The power cord should be disconnected from the MasterTech when installing or replacing fuses. Failure to do so could result in electrical shock.

- a.) Observe the position of the fuse block, using the previous figure for reference. If the single-fuse arrangement is preferred, position the fuse block so that the side with the single-fuse slot and the jumper bar is away from the cover.

If the double-fuse arrangement is preferred, position the fuse block so that the side with the double-fuse slots is away from the cover.

- b.) If the fuse block is positioned properly for the fusing, proceed to Step c.

If the fuse block is not positioned properly for the fusing:

- 1) Remove the fuse block retaining screw.
- 2) Lift the fuse block from the cover.
- 3) Rotate the fuse block.
- 4) Mount the fuse block to the cover.
- 5) Replace the retaining screw.



The fuses used in the MasterTech must be identical in type and rating to that specified. Use of other fuses could result in electrical shock and/or damage to the MasterTech.

- c.) Insert appropriate fuse(s) for the input power source. Refer to the chart below for the appropriate fuse rating.

<u>Power Source</u>	<u>Fuse</u>
100-120 VAC	3AG, 2.00 Amp Slow-Blow
200-240 VAC	5 × 20 mm, 1.00 Amp Slow-Blow (Type T)

7. Insert fuse block and cover assembly into input power connector (as shown in the following illustration) and snap it into place. Once the fuse block and cover assembly are in place, the position of the indicator pin shows the input power selected.

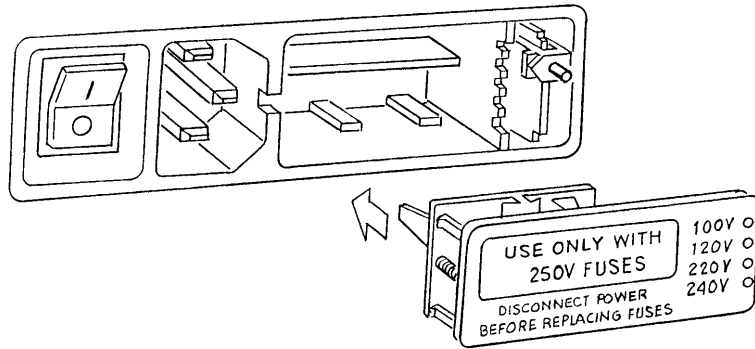

Turning on the MasterTech

1. Ensure the proper operating voltage and fuse are selected and in place.

Place the POWER ON/OFF switch, located on the MasterTech rear panel, in the ON (|) position. The +5 and +24 LEDs on the rear panel and some of the LEDs in the front panel switches should illuminate.

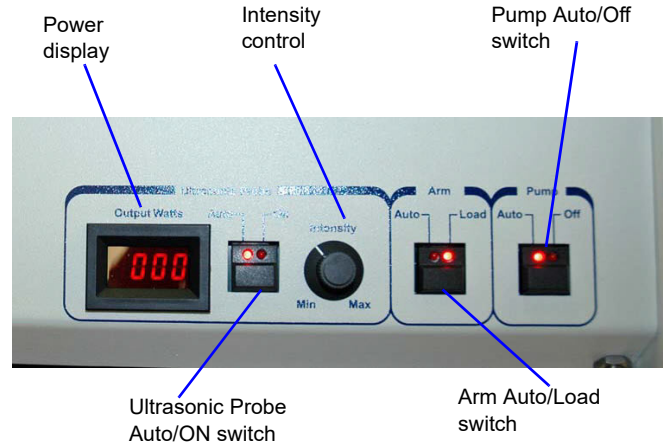
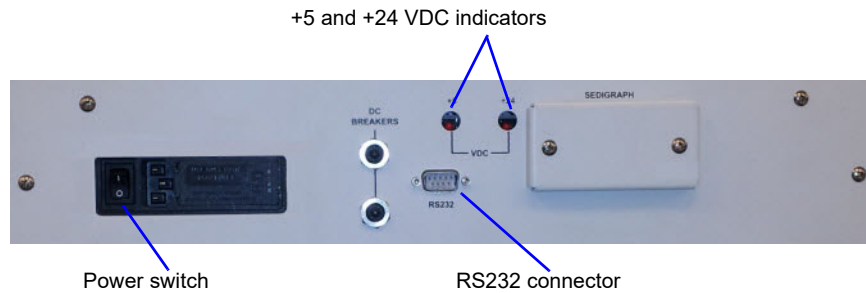

The ultrasonic probe should not be turned on at this point. Check the indicator on the ULTRASONIC PROBE AUTO/ON switch on the front panel of the MasterTech. If the ON indicator is illuminated, press the switch to turn off the probe. The indicator below AUTO should illuminate.

2. Press the ARM AUTO/LOAD switch on the front panel of the MasterTech. The arm should rise to the Load position, which is used for removal and replacement of the tray.

Installing the Beaker Tray

1. Ensure the arm of the MasterTech is in the Load (uppermost) position. When the arm is in the Load position, the Load LED is illuminated. If the Load LED is not illuminated, press the ARM AUTO/LOAD switch.
2. Hold the tray firmly by the outside edge. The bottom of the tray has small slots positioned radially outward from the inside edge. Place the tray on the MasterTech so that the arm passes through the center opening of the tray.
3. Ensure the drive pin is lined up into a radial slot on the bottom of the tray. The position of the tray does not matter at this point.



The front panel on your MasterTech may differ slightly from your MasterTech.

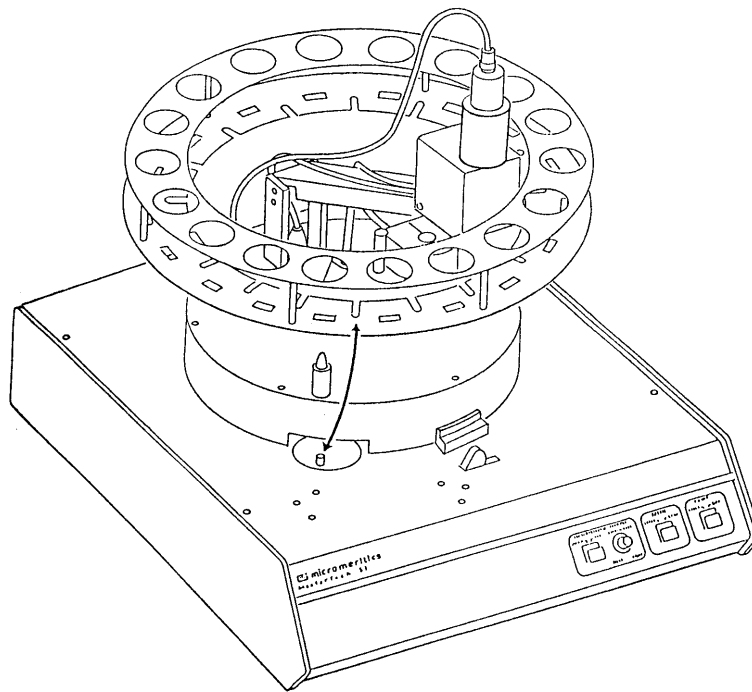

Connecting Cables

1. Position the MasterTech next to the SediGraph. Ensure the units are level and their bases are at the same height. Alternately, the MasterTech may be placed on top of the SediGraph.
2. Ensure that the power switches on the SediGraph and MasterTech are in the OFF position.
3. Insert one end of the serial cable into the MasterTech connector on the side panel of the SediGraph.

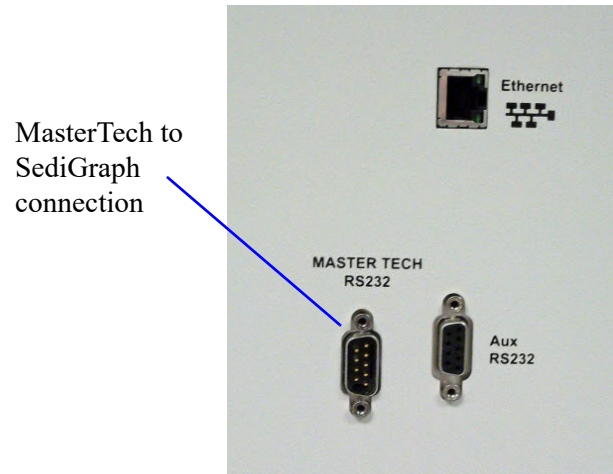

4. Insert the other end of the cable into the connector labeled **MasterTech RS232** on the back of the MasterTech.

Installing the Ultrasonic Probe



Ensure that no power is supplied to the unit before starting this procedure.

1. The ON/OFF power switch on the rear panel of the MasterTech should be in the OFF (O) position.
2. Attach the probe cable to the connector labeled **Ultrasonic Probe**.

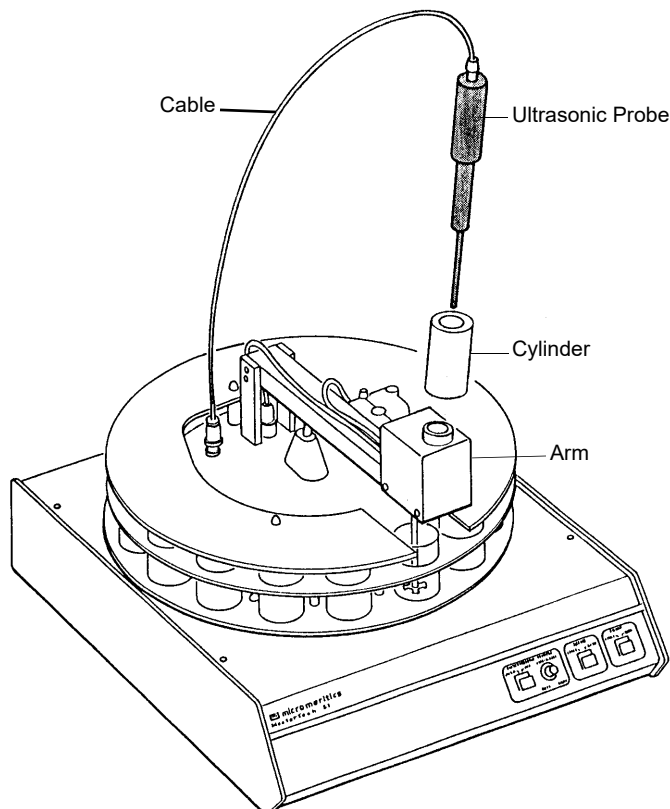

3. Ensure that the probe tip is attached to the probe; if not, attach it. A 1/4 in. probe tip is supplied with the MasterTech 052. A 1/8 in. tip is also available.
4. Insert the cylinder into the arm. Position the cylinder so that the longer slots slide over the protrusions inside the arm.



Position the shorter slots of the cylinder over the protrusions if using the 1/8 in. probe.

5. Insert the probe into the cylinder.

Installing Sample Transfer Tubing

Separate instructions are provided for installing sample transfer tubing into:

- a MasterTech with a serial number 500 or below, and
- a MasterTech with a serial number 501 or above.

MasterTech with Serial Number 500 or Below

1. Ensure that the MasterTech POWER switch is in the ON position and that the the arm is in the LOAD (uppermost) position; the LOAD LED is illuminated. If the LED is not illuminated, press the ARM AUTO/LOAD switch.
2. Several segments of flexible tubing are supplied with the MasterTech. Press the end of one segment of flexible tubing over the sample transfer tube until there is at least 1/2 in. (1.27 cm) overlap.

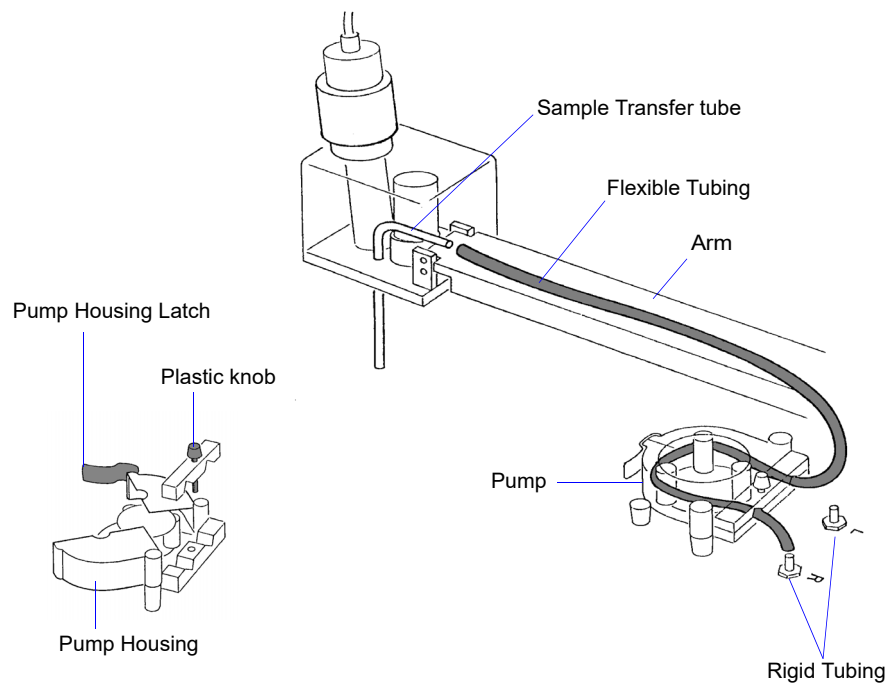

3. Unlatch the pump housing and unscrew the plastic knob on the rear of the pump.
4. Thread the tubing through the pump as shown above and attach it to the rigid tubing labeled **L** (left) or **R** (right). Choose the rigid tubing labeled with the side of the MasterTech from which you want the fluid to be discharged.
5. Close and latch the housing. Tighten the plastic knob on the rear of the pump sufficiently to prevent tubing slippage but not enough to restrict flow through the tubing.
6. Open the pump chassis cover on the SediGraph by pulling it forward.

7. Drain the system.
8. Cut the flexible tubing labeled **F** midway between the mixing pump and the rigid tubing connector on the SediGraph. Remove and discard the segment remaining on the rigid tubing connector.
9. Remove a segment of flexible tubing from the accessories kit and cut a length of tubing approximately 1 1/2 in. (3.81 cm).
10. Attach the end of another segment of tubing to the Discharge Tube connector on the front of the MasterTech.



If the MasterTech is located on top of the SediGraph, use the longer segment of tubing (P/N 052-32802-00).

11. Thread the other end of the tubing through the hole in the analyzer lower front panel.
12. Attach tubing to the Y-connector as shown below.

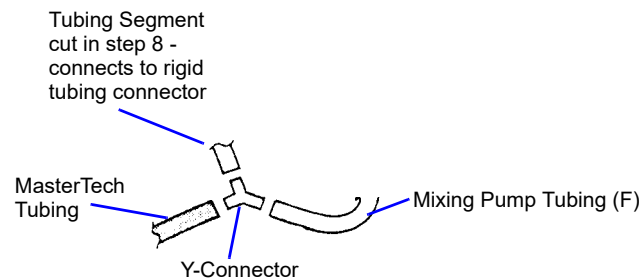

13. Attach the tubing from the Y-connector to the rigid tubing connector on the analyzer.

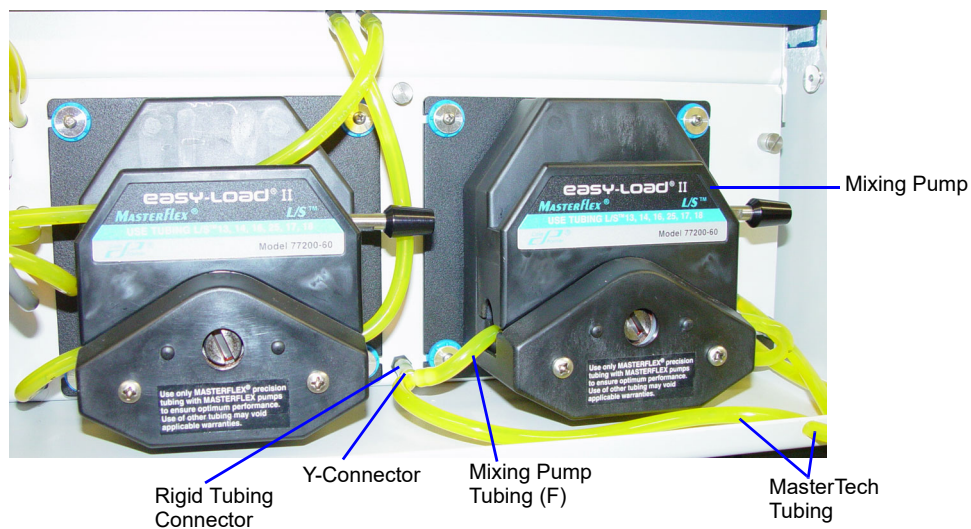

14. Close the pump chassis cover.

MasterTech with Serial Number 501 or Above

1. Ensure that the arm is in the Load (uppermost) position. When the arm is in the Load position, the Load LED is illuminated. If the LED is not illuminated, press the ARM AUTO/LOAD switch.

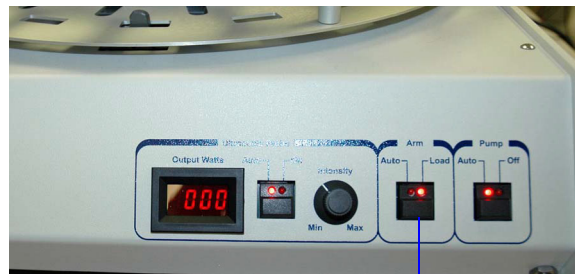

Load position

2. Unscrew the two thumbscrews from the cover of the pump housing, then remove the cover.



A

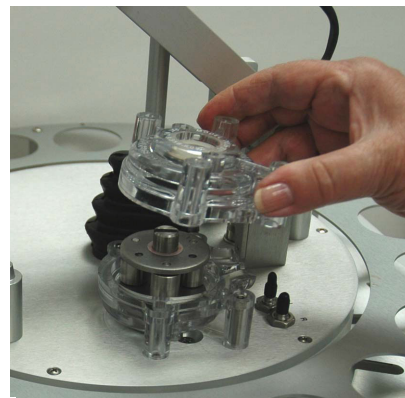

B

3. Remove the cover from one of the steel tubes labeled **L** (Left) or **R** (Right). Choose the steel tube labeled with the side of the MasterTech from which you want the fluid to be discharged. Attach one end of the flexible tubing to the steel tube. A 21 in. segment of flexible tubing is shipped with the MasterTech.



A



B

4. Loop the tubing around the pump rollers in a clockwise direction. Use one hand to hold the two ends of the tubing loop in the two grooves at the base of the pump.



5. Insert the key between the pump rollers near the left side of the pump base. The key blade must be between the tubing and the plate on the top of the rollers.

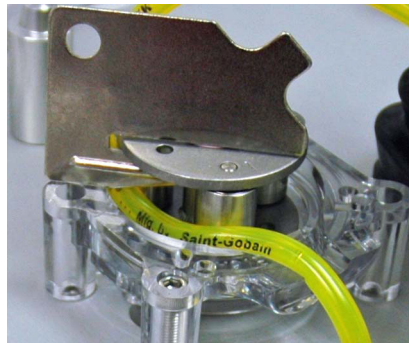

6. Turn the key clockwise so the tubing presses into the groove until the key is stopped by the peg in the right side of the pump body.

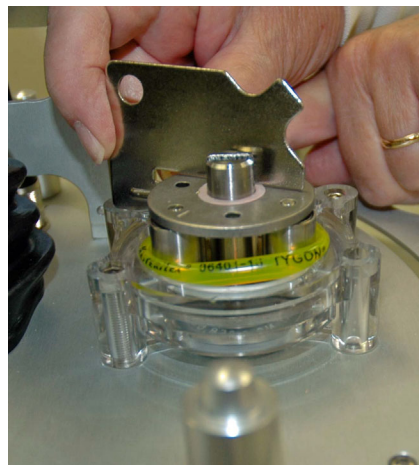

- Slide the key out, then place the cover over the pump, wiggling it slightly to align it with the pump body and press it into place. Insert and tighten the two thumbscrews only tight enough to secure the cover.

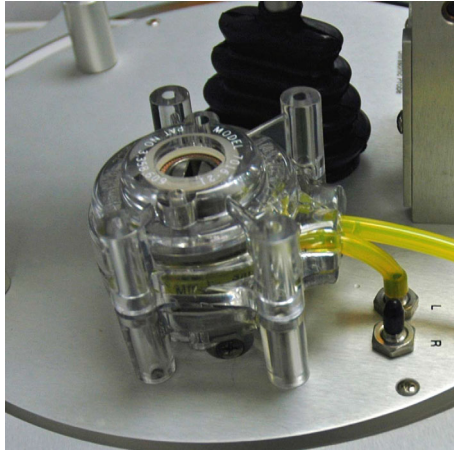

A

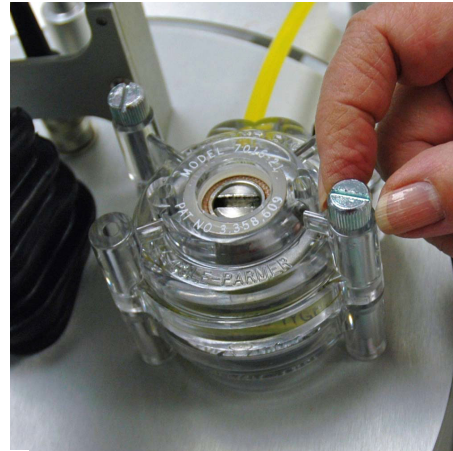

B

- Attach the other end of the flexible tubing to the Sample Transfer tube on the front of the MasterTech.



- With the instrument schematic displayed, enable Manual Mode. Right-click the **MasterTech Pump** icon and select **Turn On**.
- The pump should begin operating. If the pump does not start or is sluggish, pull on the long end of the tubing to create tension and pull excess tubing out of the pump, no more than 1/4 in. should be

required. (Loosen the thumbscrews if necessary.) When the pump is operating freely, hand-tighten the two thumbscrews, then turn the pump off.

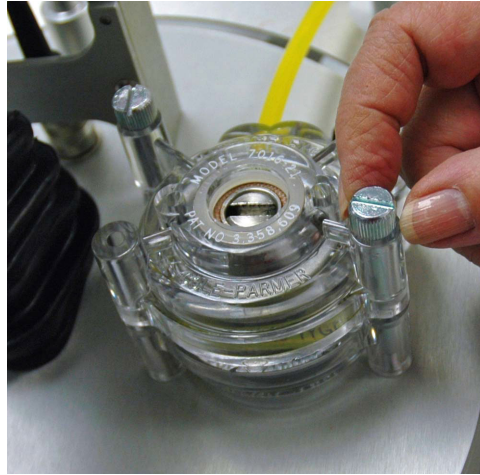

11. Press the ARM AUTO/LOAD switch to place the arm in the AUTO position.
12. Open the pump chassis cover on the SediGraph by pulling it forward.
13. Drain the system.
14. Cut the flexible tubing labeled **F** midway between the mixing pump and the rigid tubing connector on the SediGraph. Remove and discard the segment remaining on the rigid tubing connector.
15. Remove a segment of flexible tubing from the accessories kit and cut a length approximately 1 1/2 inches (3.81 cm).
16. Attach the end of another segment of tubing to the Discharge Tube connector on the front of the MasterTech.



If the MasterTech is located on top of the SediGraph, use the longer segment of tubing (P/N 052-32802-00).

17. Thread the other end of the tubing through the hole in the analyzer lower front panel.

18. Attach tubing to the Y-connector as shown below.

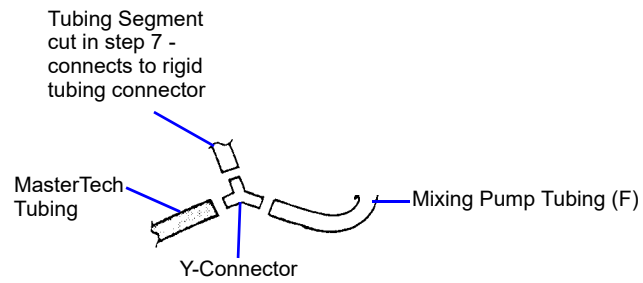

19. Attach the tubing from the Y-connector to the rigid tubing connector on the analyzer.

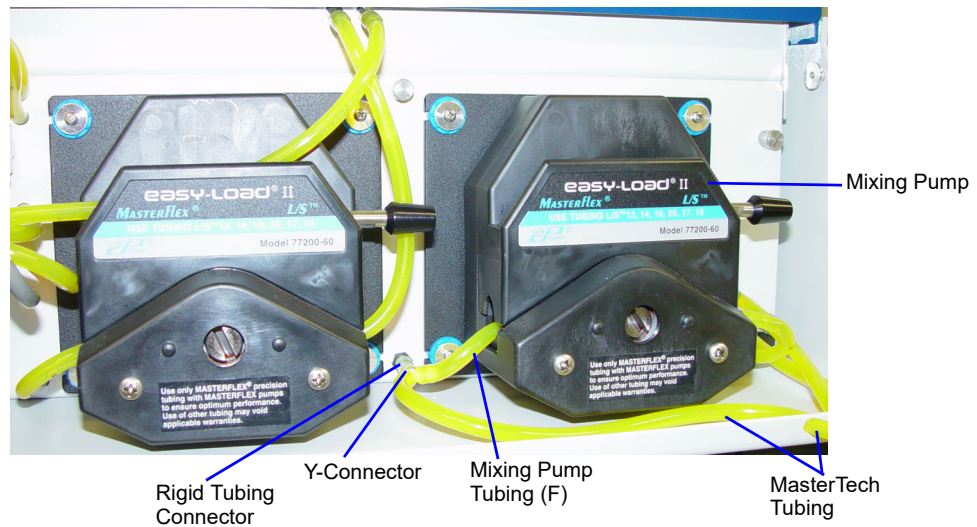

20. Close the pump chassis cover.

Verifying Operation

To verify operation, manually move each subsystem using the manual control option of the SediGraph analysis program.

1. Ensure that the SediGraph and MasterTech are turned on. Start the SediGraph analysis program if it has not been started.
2. Fill at least one of the supplied beakers with approximately 80 mL of water.
3. Place the beaker in the position numbered **1** on the tray.
4. To test the ultrasonic probe, remove it from the holder and insert the tip of the probe well into the water.



NEVER operate the ultrasonic probe without having the tip immersed into a liquid. Doing so may harm the probe and/or the driving electronics. DO NOT let the tip of the probe come in contact with a glass beaker. Doing so may shatter the beaker.

5. While holding the probe tip under water, press the ULTRASONIC PROBE AUTO/ON switch. A high-pitched sound indicates that the probe is working properly.



DO NOT press the ultrasonic probe AUTO/ON switch unless the probe and its cable are properly connected to the MasterTech. Doing so may harm the driving electronics.

6. Press the ultrasonic probe AUTO/ON switch again to turn off the probe.
7. Place the probe back into the holder.

8. Go to **Unit [n] > Enable manual control**. If necessary, go to **Unit > Show Instrument Schematic** to display the instrument schematic.

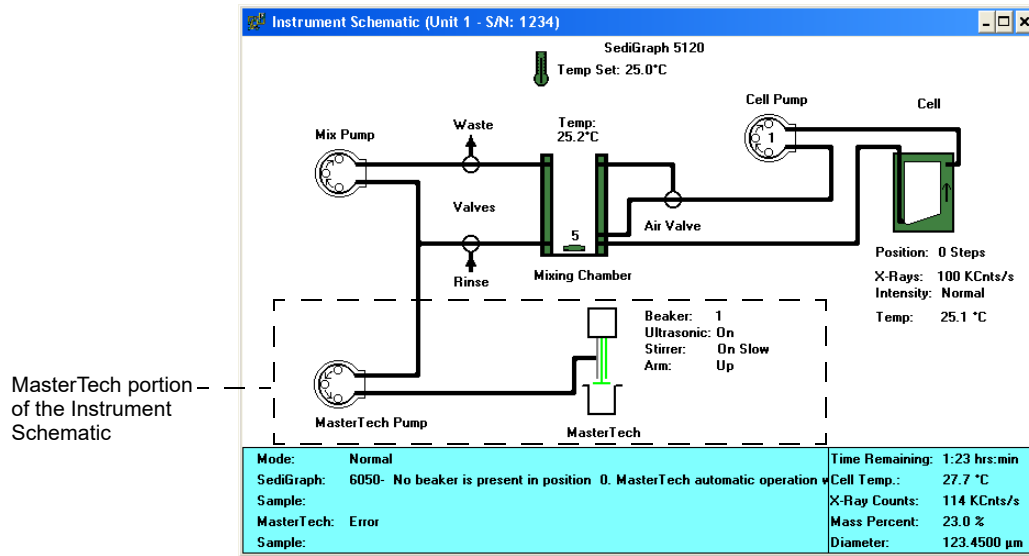

9. If the arm is in the Load position, press the ARM AUTO/LOAD switch on the front panel of the MasterTech to release it.
10. Go to **Unit [n] > Initialize MasterTech** to initialize the MasterTech. Click **CONTINUE** on the popup message.

A message is displayed indicating initialization is in process. The tray on the MasterTech rotates in a counterclockwise direction for one position, and the arm lowers to the Rinse position then returns.

The tray continues to rotate until position 1 is reached. The beaker inserted in the tray in Step 3 should now be directly under the head of the MasterTech. Ensure that the beaker contains approximately 80 mL of water.

11. On the instrument schematic, select the symbol representing the MasterTech arm.

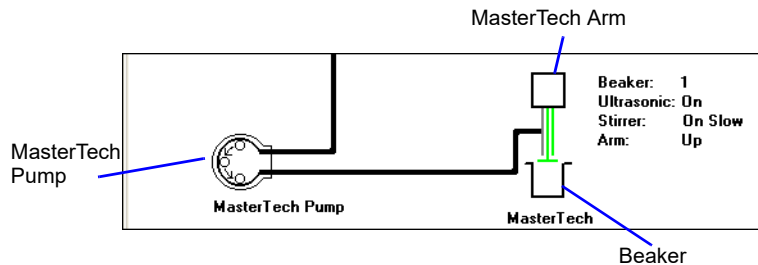

When manual mode is enabled, components on the instrument schematic have pop-up menus displaying the options available for that component. Right click a component to display pop-up menus.

In each of the following steps, first access the pop-up menu:

- a.) Select **Move Arm Down**; then repeat the step.
 - b.) Select **Ultrasonic On**. A high-pitched sound indicates the probe is operational. Select **Ultrasonic Off**.
 - c.) Select **Stirrer On**. The stirrer begins to operate.
 - d.) Select **Stirrer Speed Fast**.
 - e.) Select **Ultrasonic Off**.
 - f.) Select **Stirrer Off**.
 - g.) Select **Move Arm Up**.
 - h.) Select **Move Arm Up**.
 - i.) Select **Move To Next Beaker**. The display updates to reflect the position of the beaker tray. The picture on the screen should reflect whether or not a beaker is present.
12. Select the MasterTech pump. In each instruction in this step, first access the pop-up menu:
- a.) Select **Turn On**; the MasterTech pump should begin operating. A whirring sound can be heard then the pump will begin to operate.
 - b.) Check the direction of the flow of the MasterTech pump:
 - **Flow Direction Load** - allows suspension to flow from the MasterTech to the SediGraph. This direction is used to load the sample into the mixing chamber of the SediGraph.
 - **Flow Direction Rinse** - allows suspension to move from the SediGraph to the MasterTech. This direction is used to rinse the sample from the stirrer and transfer tube on the MasterTech.

INDEX

A

Absorption

- baseline, [E-9](#)
- full scale, [E-10](#)
- X-ray, [E-9](#)

Accessories, ordering, [8-1](#)

Add button

- in liquid properties, [3-13](#)
- in Regression reports, [5-1](#)

Advanced command, [2-4](#)

Advanced format

- defined, [2-3](#)

Air valve

- changing position in manual control mode, [4-25](#)

Analyses

- high resolution, [4-9](#)
- high speed, [4-9](#)
- preparing for, [2-17](#)
- reference material, [7-6](#)
- results relative to other methods, [F-1](#)
- selecting number to perform, [3-8](#), [3-20](#), [3-24](#), [4-4](#)
- selecting report options, [4-2](#)
- selecting type, [3-14](#), [4-9](#)
- standard, [4-9](#)
- time, [3-15](#)

Analyses counter, [4-33](#)

- resetting, [4-33](#)

Analyses, performing, [2-21](#)

- MasterTech Automatic method, [4-10](#)
- MasterTech Schedule method, [2-31](#), [4-12](#)
- Quick Start method, [4-6](#)
- Sample Analysis method, [2-21](#)

Analysis cell

- cleaning, [7-8](#)
- draining, [2-17](#)
- movement, [E-8](#)
- moving in manual control mode, [4-26](#)
- replacing assembly, [7-22](#)
- replacing tubing, [7-14](#)
- replacing windows, [7-21](#)
- rinsing, [4-19](#)
- zeroing position in manual control mode, [4-27](#)

Analysis Conditions

- Material Properties, [2-9](#)

Analysis conditions

- command, [3-11](#)

Analysis conditions command, [2-9](#), [2-11](#)

Analysis liquids

See Liquids

Analysis Options, [2-8](#)

Analysis options, [2-9](#)

Analysis program

- using, [1-11](#)
- version number, [1-15](#)

Analyzer

- cleaning, [7-6](#)
- description, [1-4](#)
- leveling, [7-18](#)
- maintaining, [7-5](#)
- rinsing, [2-33](#), [4-19](#)
- routine maintenance, [7-20](#)
- RS232 connector, [1-7](#)
- side panel, [1-7](#)
- specifications, [1-16](#)
- turning on and off, [1-10](#)

Analyzing file status, [1-13](#)

Apply Changes button

- in material properties, [3-17](#)

ARM AUTO/LOAD switch, [1-8](#)

Autorinse, [2-34](#), [3-20](#), [4-19](#)

- specifying options, [6-4](#)

Autoscale

- in Control Chart reports, [5-12](#)
- selecting options, [3-26](#), [5-8](#)
- when merging data, [3-29](#)

Aux RS232 port, [1-7](#)

Axis coordinates, viewing, [5-28](#)

Axis range

- specifying beginning and ending values, [3-26](#)

B

Baseline

- displaying date and average intensity of latest, [4-32](#)
- latest, [2-20](#)
- measuring, [2-19](#), [4-15](#)
- measuring alternately with samples, [4-12](#)
- performing a series of measurements, [4-12](#)
- previous, [2-20](#)

Baseline command, [2-19](#)

Baseline Measurement dialog, [2-19](#)

Baseline report, [5-4](#)

Basic command, [2-1](#)

Basic format

- defined, [2-3](#)
- sample information file, [2-6](#)
- sample information files, [2-6](#)

Beaker
 redispersing sample in, 4-10
 starting beaker in automatic analysis, 4-10

Beaker tray, 1-5
 aligning, 4-23
 installing, L-6

Beamsplit, E-7
 finding in manual control mode, 4-27

Bezel, cleaning mixing chamber, 7-6

Board ID button, 4-33

Board ID dialog, 4-33

Boards
 See Circuit boards

Bubble detection, 7-23

Bubbles
 detection, E-11
 determining cause, 7-23
 elimination, E-11

C

Calculations
 arithmetic, J-8
 data, J-1
 geometric, J-10

Calibration
 displaying data, 4-33

Calibration command, 4-34

Cautions, 1-8

Cautions, defined, 1-3

Cell pump
 changing flow direction in manual control mode, 4-26
 checking operation, 7-17
 replacing tubing, 7-13
 resetting, 7-23
 selecting speed, 3-19, 3-20, 4-20, 4-22

Circuit boards
 displaying identification, 4-33

Cleaning
 air filter, 7-15
 analysis cell, 7-8
 analyzer, 7-6
 collimating slits, 7-18
 mixing chamber, 7-6
 mixing chamber bezel, 7-6

Clear button, 3-9
 in particle size or sieve table, 3-28

Collected data, 3-27

Collected Data dialog, 3-27

Collimating slits
 cleaning, 7-18

Common fields and buttons
 for file menu, 3-1

 for reports menu, 5-1
 for unit menu, 4-2

Complete file status, 1-13

Control Chart
 calculations, J-14

Control Chart report
 recalculating archived results, 5-12
 selecting statistics, 5-11

Control chart report, 5-10

Conventions
 Caution, 1-3
 Notes, 1-3
 Warning, 1-3

Cumulative Data
 calculation, J-5

D

Data
 selecting display options, 6-2

Data points table, 3-25

Data presentation command, 6-2

Default sample information file, 2-38, 6-3

Delete button, 3-9
 in liquid properties, 3-13
 in particle size or sieve table, 3-28

Density, 3-8, 3-21, 4-4
 values, G-1

Diameter
 particle range, 1-16
 starting and ending, 3-14

Dimensions
 MasterTech, 1-17
 SediGraph, 1-17

Dispersant
 Sedisperse, I-1
 sources, H-1

Dispersants, changing during analysis, 4-13

Dispersion
 chemical aids, C-1
 methods, B-1

Drain and load command, 2-17

Drain and load operation, 2-17
 methods of performing, 4-17

Draining the system, 7-11

E

Edit button
 in MasterTech Schedule analysis, 4-14
 in Repeat Schedule analysis, 4-9

Entered data, 3-30

Entered file status, 1-13

Ethernet port, 1-7

Export
 sample files, 3-3
Export command, 2-40
External data
 entering, 3-30
 merging, 2-7, 3-28, 4-4
External Data button, 3-9, 3-28

F

File
 list, 2-42
File menu
 Analysis conditions command, 3-11
 Common fields and buttons, 3-1
 Exit, 2-45
 Report command, 3-23
File name, default extensions, 3-5
File names
 conventions, 1-13
Filter
 See Air filter
Flexible tubing
 See Tubing
Format
 Advanced, 2-3
 Basic, 2-3
 Restricted, 2-3
Frequency
 MasterTech, 1-17
 SediGraph, 1-16
Full scale mass percent, 3-10, 3-29, 4-4
Fuse
 MasterTech, 1-17

G

Graph
 copying as metafile, 5-27
 editing onscreen, 5-24
Graphs
 selecting grid line type, 6-2
 showing and hiding gridlines, 6-2

H

Help
 online manual, 1-15
Help menu, 1-15
Humidity, 1-17

I

Insert button, 2-28, 2-31
 in particle size or sieve table, 3-28
 in Repeat Schedule analysis, 4-9
Installing
 beaker tray, L-6
 MasterTech, L-1
 ultrasonic probe, L-8
Instrument log, 4-30
 printing a report, 4-31
Instrument schematic, 4-24
 description, 4-28
 displaying, 4-28
INTENSITY control, 1-8

L

Level indicator, 7-18
Leveling analyzer, 7-18
Liquid properties, 2-8
 changing, 3-12, 3-13, 3-21
 entering, 3-21
 Interpolation calculations, J-2
 values, 3-22
Liquid properties command, 2-12
Liquid Properties dialog, 3-21
Liquids, 1-17
 See also Sedisperse dispersing liquids
 adding in analysis program, 3-12, 3-13
 adding properties in analysis program, 3-13
 analysis, 3-13
 suspending, 1-16, 1-17
List command, 2-42
List file statistics, 3-3
Log
 See Analysis Log
Log Probability Data, J-15
Log Probability Interpolation Table, J-15

M

Main Menu bar, 1-14
Main menu bar, 1-14
Maintenance
 system, 7-1
Maintenance schedule, 7-5
Manual control mode
 enabling, 4-24
 pop-up menus, 4-24
Mass Data
 calculation, J-4
Mass Frequency Data, J-4
Mass Percent

- calculation, [J-3](#)
 - Mass percent
 - specifying ending percent finer, [3-20](#)
 - stop at specified, [3-20](#)
 - MasterTech
 - +5 and +24 VDC indicators, [1-9](#)
 - ARM AUTO/LOAD switch, [1-8](#)
 - connecting cables, [L-7](#)
 - connecting to SediGraph, [L-7](#)
 - controls and indicators, [1-8](#)
 - description, [1-5](#)
 - dimensions, [1-17](#)
 - front panel, [1-8](#)
 - fuse type, [L-4](#)
 - initializing, [4-23](#)
 - installing beaker tray, [L-6](#)
 - installing sample transfer tubing, [L-9](#)
 - installing ultrasonic probe, [L-8](#)
 - INTENSITY control, [1-8](#)
 - moving arm to next beaker in manual control mode, [4-27](#)
 - moving arm up or down in manual control mode, [4-27](#)
 - Power Display, [1-8](#)
 - POWER ON/OFF switch, [1-9](#)
 - PUMP AUTO/OFF switch, [1-9](#)
 - rear panel, [1-9](#)
 - replacing input power fuse, [7-24](#)
 - rinsing, [4-21](#)
 - RS232 connector, [1-9](#)
 - selecting stirrer time and stirrer speed, [3-18](#)
 - selecting voltage, [L-1](#)
 - specifications, [1-17](#)
 - troubleshooting, [7-4](#)
 - turning on, [L-5](#)
 - Material Properties, [2-9](#)
 - Material properties, [2-8](#), [3-11](#)
 - updating, [3-16](#)
 - Mean
 - calculation, [J-8](#)
 - Mixing chamber, [1-7](#)
 - cleaning, [7-6](#)
 - cleaning bezel, [7-6](#)
 - increasing or decreasing stirrer speed, [4-18](#)
 - rinsing, [4-19](#)
 - selecting speed in manual control mode, [4-25](#)
 - stirrer speed, [3-20](#)
 - Mixing pump
 - checking operation, [7-16](#)
 - replacing tubing, [7-12](#)
 - resetting, [7-23](#)
 - turning on and off in manual control mode, [4-25](#)
 - Mode
 - calculation, [J-8](#)
 - Multiple graph overlays, [2-46](#)
- ## N
- No analysis* file status, [1-13](#)
 - Notes, defined, [1-3](#)
 - Number Frequency Data
 - calculation, [J-7](#)
- ## O
- ON/OFF switch, analyzer, [1-7](#)
 - ON/OFF switch, MasterTech, [1-9](#)
 - Open command, [3-5](#)
 - Opening
 - files, [3-5](#)
 - Operator's manual, conventions, [1-3](#)
 - Option Presentation
 - Advanced Format, [6-1](#)
 - Options menu
 - Service Test mode, [6-5](#)
 - Ordering information, [8-1](#)
 - Out of Spec calculations, [J-11](#)
 - Overflow tube, [2-33](#), [2-35](#)
 - Overlays
 - creating the same graph for all tests from one sample file, [2-52](#)
 - creating the same graph for multiple samples, [2-49](#)
 - Generating, [2-46](#)
 - generating, [2-46](#)
 - multiple graphs, [2-46](#)
 - selecting type, [3-26](#)
 - Overlays button, [2-16](#)
- ## P
- Parameter files, defining, [2-8](#)
 - Particle size distributions, [F-2](#)
 - Particle size table, [3-9](#), [3-28](#)
 - Parts, ordering, [8-1](#)
 - Peak Report Data
 - calculation, [J-5](#)
 - Plot type, [3-26](#)
 - Power
 - MasterTech, [1-17](#)
 - SediGraph, [1-16](#)
 - Print command, [2-39](#)
 - Printer
 - specifying, [6-4](#)
 - Printing
 - instrument log report, [4-31](#)
 - Probe
 - See* Ultrasonic probe

Properties button, 3-13
PSD History report, 5-14
PUMP AUTO/OFF switch, MasterTech, 1-9
Pump Control Off/Auto switch, analyzer, 1-6
Pumps
 symbols in instrument schematic, 4-24

R

Reference button
 in report options, 2-15
Reference material analysis, 7-6
Reference Quantities, J-11
Regression Chart
 calculations, J-13
Regression report
 command, 5-8
 recalculating SPC values, 5-9
 selecting axis range, 5-8
 selecting X- and Y-Axes variables, 5-8
 window, 5-8
Replacing
 analysis cell assembly, 7-22
 analysis cell windows, 7-21
 MasterTech input power fuse, 7-24
 ultrasonic probe tip, 7-24
 X-ray indicator lamps, 7-20
Report
 control chart, 5-10
 generating, 5-3, 6-1
 graphs, editing onscreen, 5-24
 header, 5-16
 shortcut menus for, 5-22
 tabular, editing, 5-23
 tool bar, 5-19
 zoom feature, 5-28
Report button, 4-4
Report Options
 command, 3-23
 list file statistics, 3-3
Report options
 ID, 3-23
Report options files, 4-4
 defining, 2-14
Reports
 Baseline, 5-4
 calculations, J-1
 closing, 5-3
 displaying during an analysis, 4-4
 examples, 5-29
 ordering by ascending or descending data, 3-25
 overlays, 2-46
 PSD History, 5-14
 selecting, 3-25

 showing graph, 3-23
 showing title, 3-23
Reports List Box, 4-4
Reports menu
 control chart command, 5-10
 regression report command, 5-8
 start report command, 5-3
Resolution, 1-16
Restricted format
 creating sample information files, 2-6
 defined, 2-3
 sample information file, 2-6
Resuspension parameters, 4-10
Reynolds number, 2-10, 3-15
 calculation, J-14
 specifying default, 6-3
Reynolds number command, 6-3
Rinse
 after analysis, 2-25, 3-9, 4-4
 cycles, 3-20, 4-19
Rinse Both command, 2-36
Rinse container
 adding surfactant, 2-33
Rinse MasterTech command, 2-35
Rinse operation, performing, 2-33, 4-19
 both SediGraph and MasterTech, 2-33, 2-36
 MasterTech, 2-33
 SediGraph, 2-33
Rinse SediGraph command, 2-34
Rinse tube, 2-33, 2-35
Rinse valve
 changing position in manual control mode, 4-25
RS232 connector, 1-9

S

Safety information
 X-ray, K-1
Sample
 See also Samples, analyzing
 beaker tray capacity, 1-17
 dispersion, B-1
 loading, 2-17
 size, 1-16, 1-17
 transfer tubing, installing, L-9
Sample Analysis command, 2-21
Sample analysis command, 4-3
Sample defaults, 6-3
Sample defaults command, 2-1
Sample Information command, 2-4, 2-6
Sample information file
 creating in Basic format, 2-6
 export, 3-3
 list file statistics, 3-3

- Sample information files
 - converting, 2-43
 - creating, 2-3
 - creating automatically in QuickStart, 4-6
 - defining, 2-1
 - Sample materials
 - adding properties in analysis program, 3-12
 - Samples, analyzing
 - a series, 4-6
 - a series with different conditions, 4-12
 - a series with the same conditions, 4-10
 - alternately with baseline collection, 4-12
 - individual samples, 4-3
 - the same sample multiple times, 4-8
 - Sedimentation
 - method of analysis, E-4
 - theory, E-1
 - Sedimentation liquids
 - See* Liquids
 - Sedisperse dispersing liquids, I-1
 - material properties, I-2
 - storage requirements, I-1
 - technical data, I-1
 - Service Test mode, 4-34
 - Service test mode, 6-5
 - Set Baseline button, 3-16
 - Set point, temperature, 4-25
 - Shortcut
 - for graphs, 5-24
 - for tabular reports, 5-23
 - Show Status command, 4-29
 - Sieve table, 3-9, 3-28
 - specifying defaults, 6-3
 - Size Statistics
 - calculation, J-8
 - SmartPrep port, 1-7
 - Software version
 - displaying, 4-32
 - Software, using, 1-11
 - SPC Analysis Options dialog, 5-6
 - SPC report
 - control chart, 5-10
 - regression, 5-8
 - SPC reports
 - selecting analysis conditions, 5-6
 - selecting parameters, 5-6
 - selecting peaks, 5-7
 - selecting percentiles, 5-6
 - SPC Sample Options dialog, 5-6
 - Specification button, 2-15
 - Specifications
 - MasterTech, 1-17
 - Standard Report Tables, J-17
 - Standard Report Tables, J-17
 - Start report, command, 5-3
 - Status display
 - lower display, 2-38
 - upper display, 2-38
 - Stirrer, MasterTech
 - changing the speed in manual control mode, 4-27
 - selecting speed, 4-14
 - selecting time, 4-10, 4-14
 - turning on and off in manual control mode, 4-27
 - Stokes' Law, D-1
 - Surface Area Frequency Data
 - calculation, J-7
 - Suspending liquids
 - See* Liquids
- ## T
- Tables
 - data points, 3-25
 - particle size, 3-28
 - sieve, 3-28
 - Tabular reports, 5-8, 5-12
 - Temperature
 - displayed, 3-15
 - MasterTech, 1-17
 - SediGraph, 1-16
 - set point, 4-25
 - setting target, 4-25
 - Temperature stabilization, 3-20
 - Title properties window, 5-27
 - Tool bar, reports window, 5-19
 - Tubing
 - analyses remaining on current set, 4-33
 - entering number of analyses per set, 4-33
 - replacing, 7-10, 7-14
 - replacing cell pump, 7-13
 - replacing mixing pump, 7-12
 - rinsing MasterTech, 4-21
 - rinsing SediGraph, 4-19
- ## U
- Ultrasonic probe, 1-5
 - AUTO/ON switch, 1-8
 - installing, L-8
 - replacing tip, 7-24
 - selecting time, 4-14
 - Unit menu
 - service test command, 4-35
 - Units, selecting, 6-2
 - Update Properties button, 3-16
 - Using the Analyzer, 1-1

V

- Verifying operation
 - MasterTech, [L-16](#)
- Viscosity, [3-21](#)
 - calculations, [J-3](#)
 - values, [G-1](#)
- Voltage
 - MasterTech, [1-17](#)
 - SediGraph, [1-16](#)
- Voltage, selecting
 - MasterTech, [L-1](#)

W

- Warnings, defined, [1-3](#)
- Waste tube, [2-33](#), [2-35](#)
- Waste valve
 - changing position in manual control mode, [4-25](#)
- Wetted materials, [1-16](#), [1-17](#)
- Window menu
 - arrange icons, [1-15](#)
 - tile and cascade, [1-15](#)
- Windows menu, [1-15](#)

X

- X-Axis
 - selecting how values are displayed, [3-26](#)
- X-axis order by, [5-10](#), [5-14](#)
- X-ray
 - absorption, [E-9](#)
 - assembly, [1-4](#)
 - safety information, [K-1](#)
 - source, [K-1](#)
 - warning and indicator lights, [K-1](#)
- X-ray indicator lamps, replacing, [7-20](#)
- X-ray intensity
 - low, [3-22](#)
 - normal, [3-22](#)
 - reduction, [2-18](#), [2-25](#)
 - selecting, [2-13](#), [3-22](#)
 - selecting in manual control mode, [4-26](#)
- X-RAY ON indicator, [1-6](#)
- X-Ray STANDBY indicator, [1-6](#)

Z

- Zoom feature, [5-28](#)

